

Description

The YB1522 is a step-up DC-DC converter; with wide input voltage range from 3V to 16V, which operates as current source to drive up to 3S7P to 3S10P (V_{IN} at 3V to 5V). Series connecting of the LEDs provides identical LED currents resulting in uniform brightness and eliminating the need for ballast resistors. The light intensity of these LEDs is proportional to the current passing through them. The YB1522 switches at a fixed frequency of ~930KHz, allowing the use of tiny, low profile inductors and capacitors to minimize footprint and cost in space consideration applications.

The YB1522 can drive up to 3S10P white LEDs from a single Li-Ion battery. At automotive (5V/12V) applications with higher conversion efficiency. To control LED brightness, the LED current can be pulsed by applying a PWM (pulse width modulated) signal with a frequency range of 100Hz to 1KHz to the CTRL pin.

YB1522 has integrated Latched Over Voltage Protection that prevents damage to the device in case of a high impedance output due to faulty LED or open circuit caused by abnormal conditions.

Features

- Built-in Internal Switch
- 3V to 16V Input Range
- <1uA Shutdown Current
- High Efficiency
- Internal Soft Start
- Drives up to 3S7P to 3S10P White LEDs(V_{IN} at 3.5V to 5V)
- Over Voltage Protection 30V
- Small 5-Lead SOT-23 Package
- Analog and PWM Dimming Control
- 100mV Low Reference Voltage

Applications

- 5" ~ 7" LCD Display Module
- White LED Backlighting
- Car TV
- Handheld and PDA
- Electronic Books
- Digital Photo Frame

Typical Application Circuit

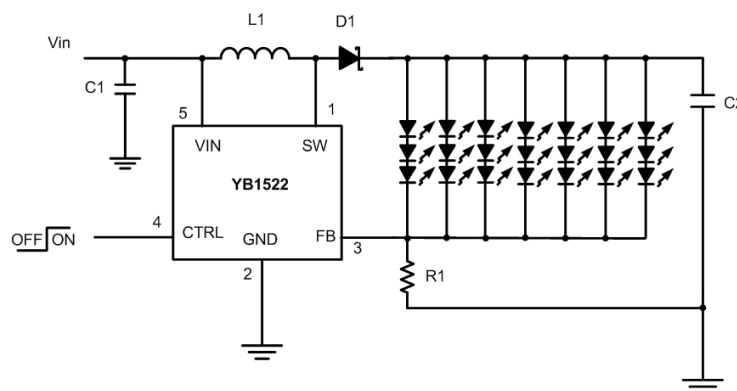

Figure 1: Typical Application Circuit

Pin Configuration

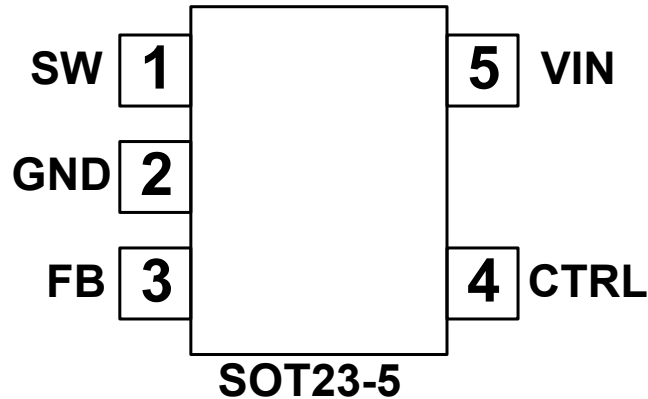

Figure 2: Pin Configuration

Pin Description

Table 1

Pin	NAME	Description
1	SW	Switching Pin. This is the collector of the internal NPN power switch. Connect to inductor and diode. Minimize the metal trace area connected to this pin to reduce EMI.
2	GND	Ground Pin. Connect directly to local ground plane.
3	FB	Feedback Pin. Reference voltage is 100mV. Connect LEDs and a resistor at this pin. LED current is determined by the resistance and CTRL voltage.
4	CTRL	Shutdown Pin and Dimming Control Pin. VCTRL > 1.8V generates full-scale LED current. VCTRL < 0.4V chip is off. Switching from 0.4V to 2.0V, PWM duty cycle controls the LED current.
5	VIN	Input Supply Pin. Bypass this pin with a capacitor as close to the device as possible.

Ordering Information

Order Number	Package Type	Supplied As	Package Marking
YB1522ST25	SOT23-5	3000 units Tape & Reel	Please contact sales representative

Absolute Maximum Ratings

V _{IN}	20V
SW Voltage	32V
FB Voltage	5V
CTRL Voltage.....	5V
Maximum Junction Temp, T _J	150°C
Lead Temperature (Soldering 10 sec).....	300°C

Recommended Operating Conditions

Operating Temperature.....	-40°C to 85°C
Supply Voltage.....	3V~16V
SW Voltage.....	20V

Electrical Characteristics

Table 2 (V_{IN} = 3.3V, C_{IN} = 1uF, C_{OUT} = 10μF, T_A=25°C, unless otherwise noted.)

Description	Symbol	Test Conditions	MIN	TYP	MAX	Units
Input Voltage Range	V _{IN}		3		16	V
Not Switching	I _Q	V _{FB} = 0.3V	1.2	1.5	1.7	mA
Shutdown		CTRL = 0V		0.3	1	uA
Feedback Voltage	V _{FB}	I _{OUT} = 20mA, V _{OUT} = 12.5V Circuit of Figure 1	90	100	110	mV
Switch Current Limit	I _{CL}	85% duty cycle	620	650		mA
		40% duty cycle		450		mA
FB Pin Bias Current	I _B	V _{FB} = 100mV			1	uA
Switching Frequency	F _{SW}		900	930	960	KHz
Maximum Duty Cycle	D _{MAX}				85	%
Minimum Duty Cycle	D _{MIN}		20		25	%
Switch V _{cesat}	V _{SAT}	At I _{SW} = 200mA			180	mV
Switch Leakage Current	I _{LKG}	CTRL = 0.3V			1	μA
V _{CTRL} for Full LED Current	V _{CTL}	Full On	1.7			V
		Full Off			0.3	V
CTRL Pin Bias Current	I _{CTL}	CTRL = 2V		40		μA
Over Voltage Protection	OVP			30		V
Over Thermal Protection	OTP			160		°C
Thermal Resistance	θ _{JA}			220		°C/W

Note :

Absolute maximum ratings are limits beyond which damage to the device may occur. The maximum allowable power dissipation is a function of maximum junction temperature, T_{J(MAX)}, the junction to ambient thermal resistance, θ_{JA}, and the ambient temperature. The maximum allowable power dissipation at any ambient temperature is calculated using: P_{D(MAX)} = [T_{J(MAX)} - T_A] / θ_{JA}. Exceeding the maximum allowable power dissipation will cause excessive die temperature. All limits at temperature extremes are guaranteed via correlation using standard statistical methods.

Typical Performance Characteristics

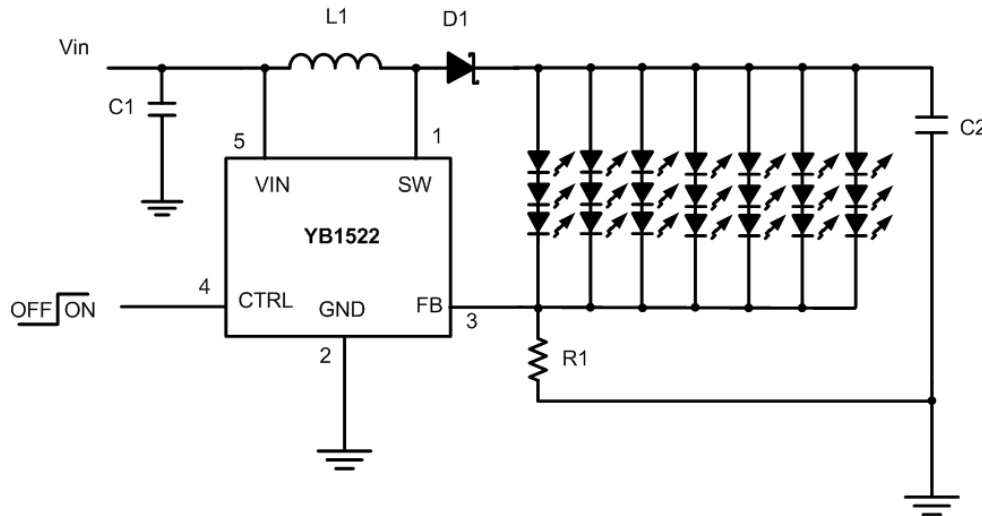

C1=1uF/16V	C2=10uF/16V
L1=33uH/CD43	R1=0.71Ω

Output Waveform

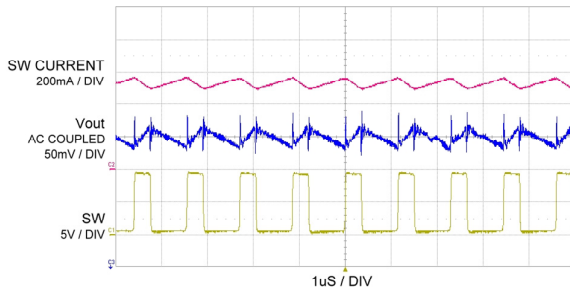

Output Ripple

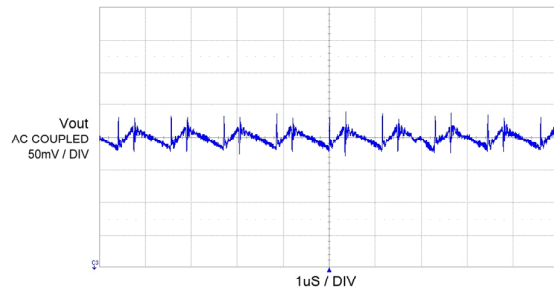

Vin & Efficiency

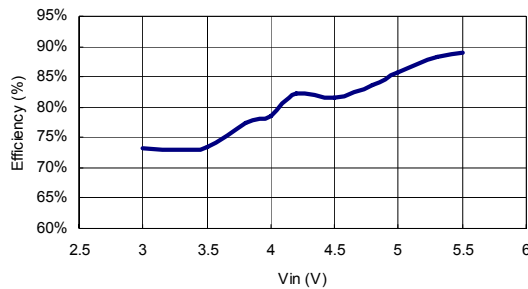

Vin & Iout

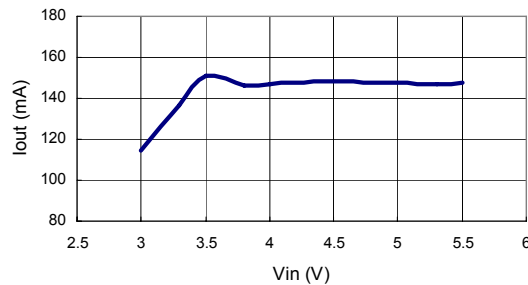

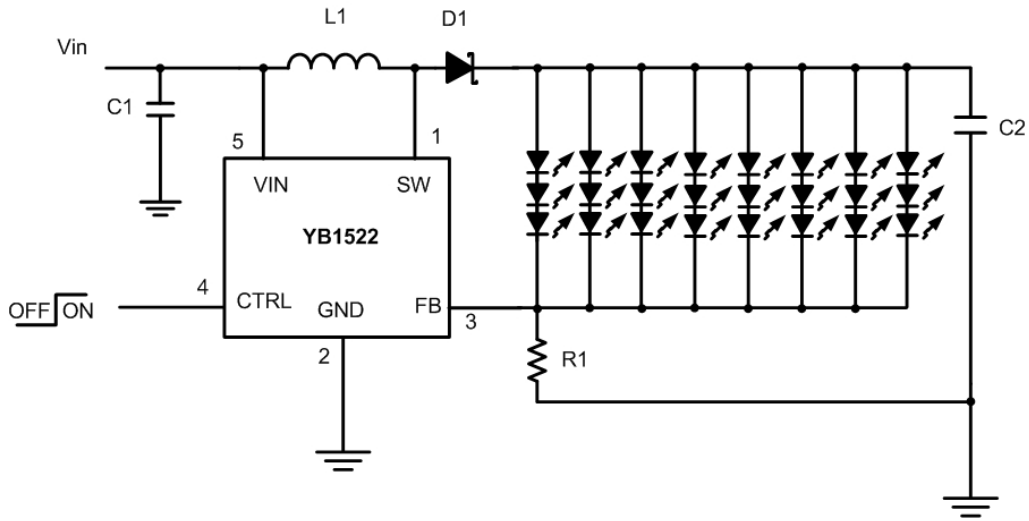

C1=1uF/16V	C2=10uF/16V
L1=33uH/CD43	R1=0.62Ω

Output Waveform

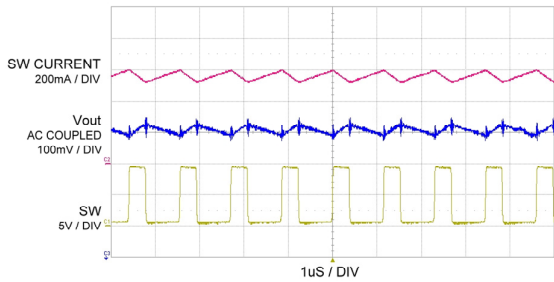

Output Ripple

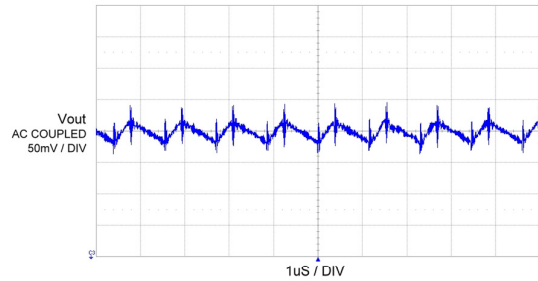

Vin & Efficiency

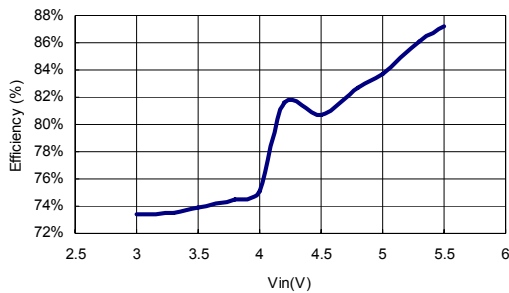

Vin & Iout

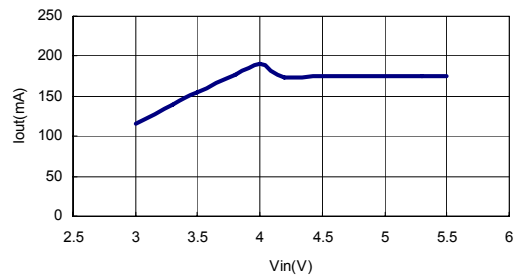

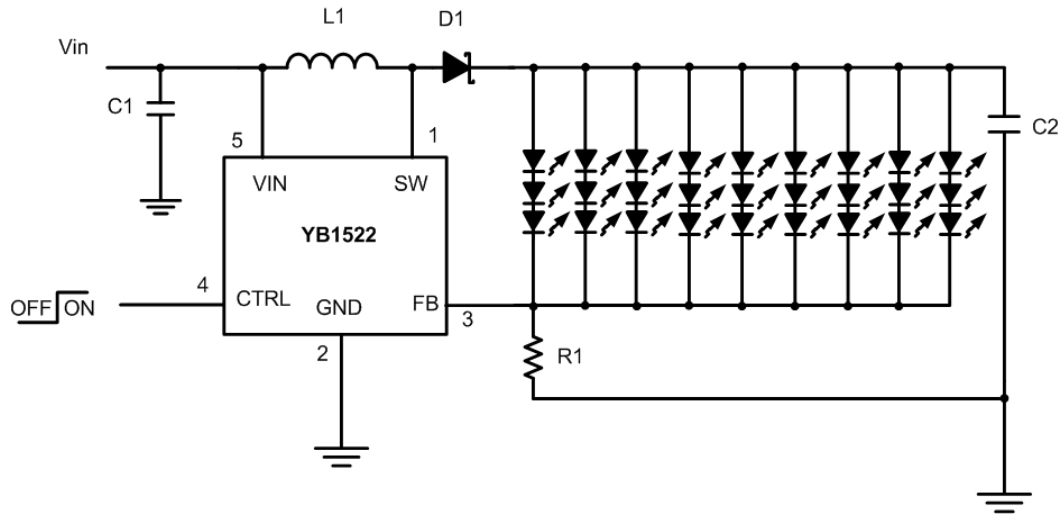

C1=1uF/16V	C2=10uF/16V
L1=33uH/CD43	R1=0.55Ω

Output Waveform

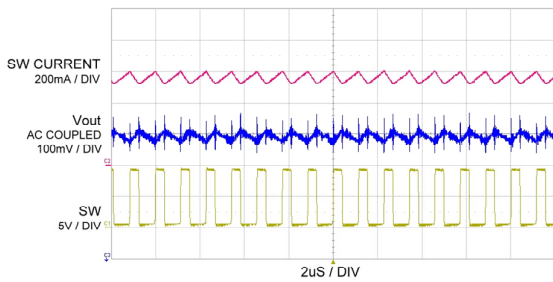

Output Ripple

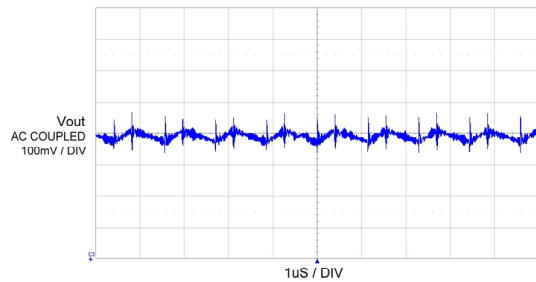

Vin & Efficiency

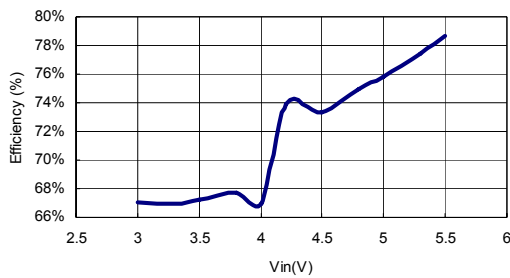

Vin & Iout

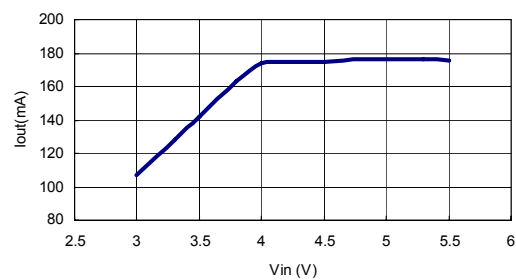

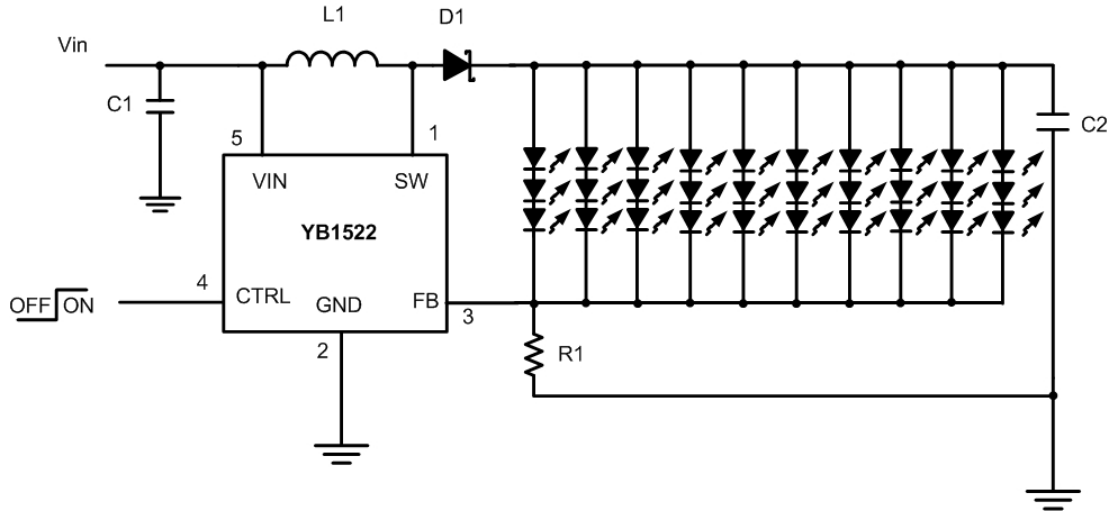

C1=1uF/16V	C2=10uF/16V
L1=33uH/CD43	R1=0.5Ω

Output Waveform

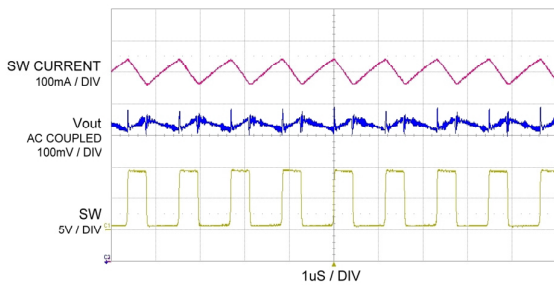

Output Ripple

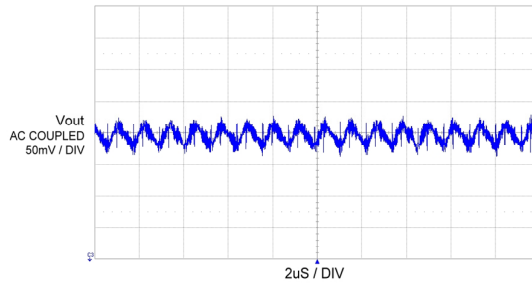

Vin & Efficiency

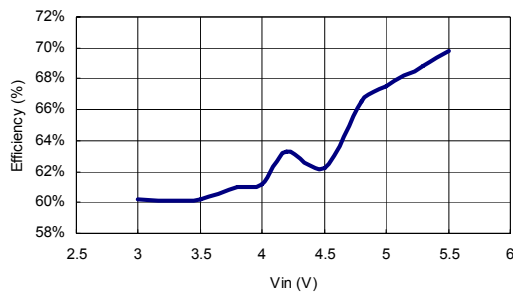

Vin & Iout

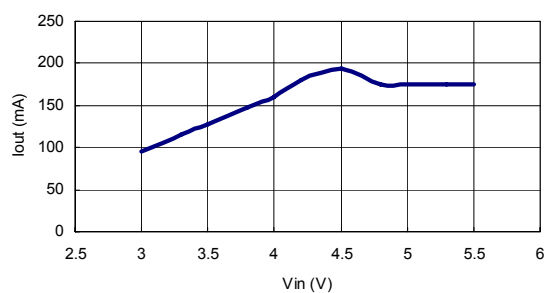

Typical Performance Characteristics

Supply Current (Vctrl = 0V)

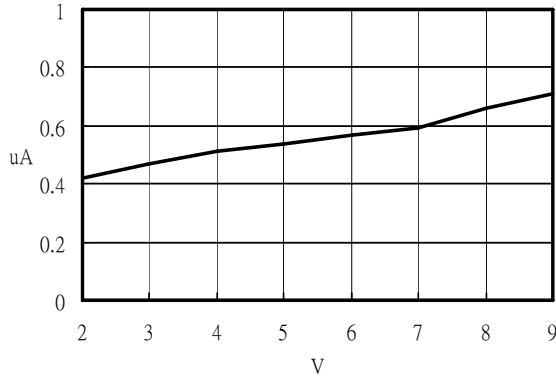

Supply Current (Vctrl = Vin)

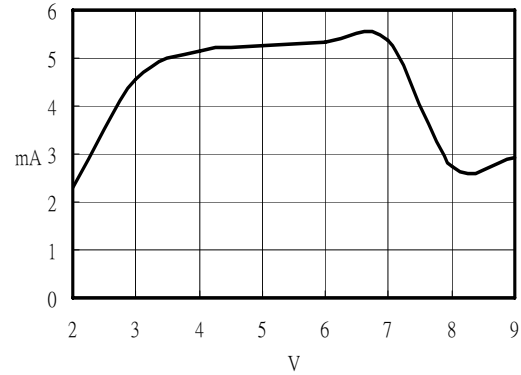

Switching Frequency

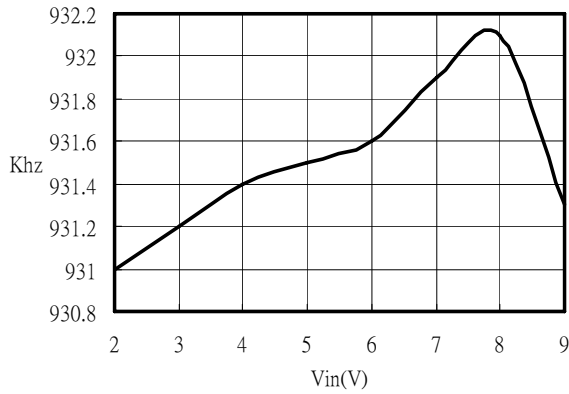

Vcesat

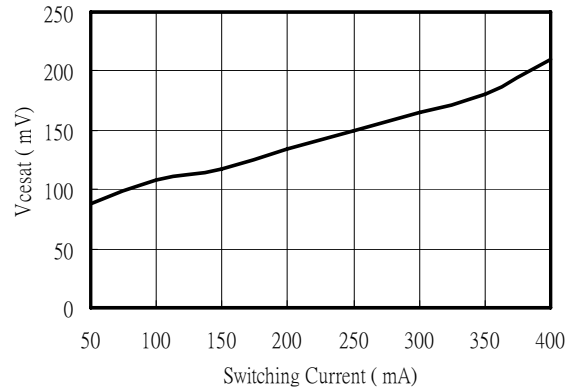

Switch Leakage Current

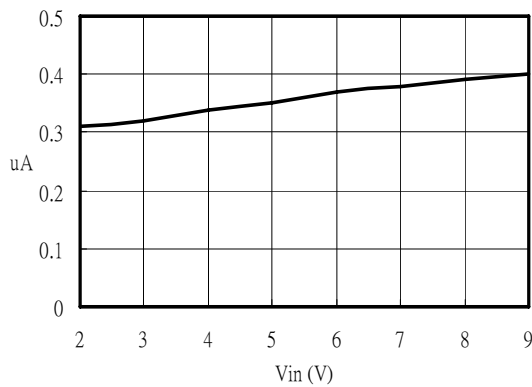

CTRL Pin Bias Current

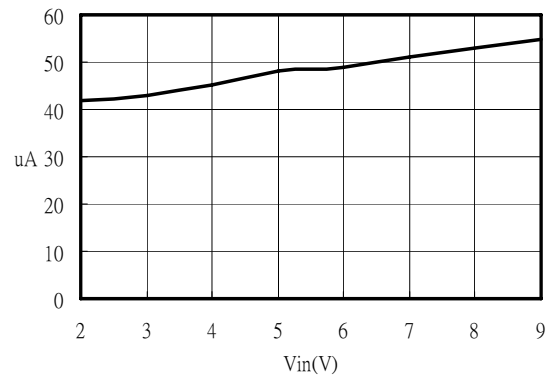

Function Block

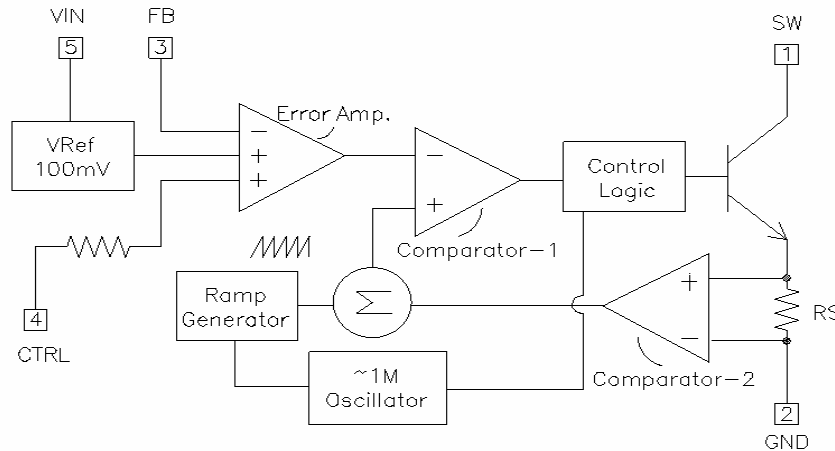

Figure 3: YB1522 Block Diagram

Operation

The YB1522 uses a constant frequency, current mode control scheme to regulate the output LED current. Its operation can be understood by referring to the block diagram in Figure 3. At the start of each oscillator cycle, a voltage proportional to the switch current is added to a ramp output and the resulting sum is fed into the positive terminal of the PWM comparator (comparator-1). When this voltage exceeds the level of the comparator negative input, the peak current has been reached, and the SR latch (in Control Logic) is reset and turns off the power switch. The voltage at the negative input of the comparator comes from the output of the error amplifier. The error amplifier sets the correct peak current level to keep the output in regulation. If the error amplifier’s output increases, more current is delivered to the output; if it decreases, less current is delivered.

Application Information

Soft Start and Current Limit

The internal soft start circuit minimizes the inrush current during turning on YB1522. The maximum switch current is limited to about 650mA by the chip.

LED Current and Dimming Control

The LED’s current is set by a resistor connected at FB pin to GND using:

$$I_{LED} = \frac{100mV}{R_{LED}}$$

The maximum LED current set initially can be reduced by pulse width modulating the CTRL. A better approach is to adjust the feedback voltage for dimming control. Either a DC level signal or a filtered PWM signal can be used to control the LED current as illustrated in Figure 4 and Figure 5 respectively. Using the above different scheme, the LED current can be controlled from 0% to 100% to its maximum value.

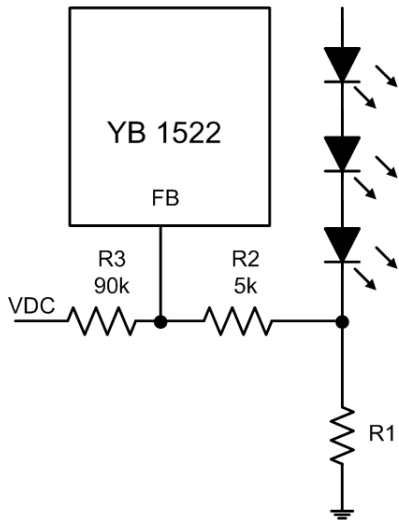

V _{DC} (V)	V _{FB} (mV)	I _{OUT} (mA)
2	0	0
1.8	2.2	0.43
1.6	9.2	1.8
1.4	19.6	3.6
1.2	31.1	6
1	43.4	8.5
0.8	63	12.3
0.6	74	14.5
0.4	86.4	16.9
0.2	96.9	19
0	102	20

Figure 4: Dimming Control Using a DC Voltage

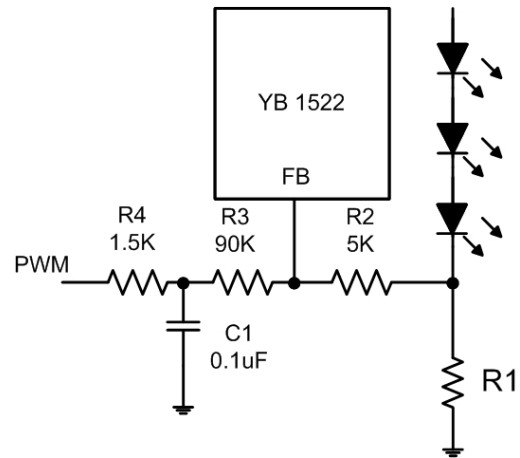

Duty	I _{OUT} (mA)
0%	20
20%	17.4
30%	15
40%	12.4
50%	10
60%	8
70%	6.4
80%	4.07
100%	0

PWM : 2V ; 1KHz ; Vin=3.6V

Figure 5: Dimming Control Using a Filtered PWM Signal

Over Voltage Protection

The YB1522 has an internal over voltage protection circuit which also acts as an open-circuit protection. In the cases of open circuit or the LEDs failure, the LEDs are disconnected from the circuit, and the feedback voltage will be zero. The YB1522 will then switch to a high duty cycle resulting in a high output voltage, which may cause SW pin voltage to exceed its maximum 30V rating. The YB1522 will shutdown automatically until input condition changes to bring it out of the shutdown mode.

Inductor Selection

A 33 μ H inductor is recommended for most applications to drive more than 3x7 WLEDs. Although small size and high efficiency are major concerns, the inductor should have low core losses at 1MHz and low DCR (copper wire resistance).

Diode Selection

To maintain high efficiency, the average current rating of the Schottky diode should be large than the peak inductor current, I_{PK} . Schottky diode with a low forward drop and fast switching speeds are ideal for increase efficiency in portable application. Choose a reverse breakdown of the Schottky diode large than the output voltage.

Capacitor Selection

Choose low ESR capacitors for the output to minimize output voltage ripple. Multilayer capacitors are a good choice for this as well. A 10 μ F capacitor is sufficient for 3x7 WLEDs applications. For additional bypassing, a 100nF ceramic capacitor can

be used to shunt high frequency ripple on the input.

The input bypass capacitor C_{IN} , as shown in Figure 1, must be placed close to the IC. This will reduce copper trace resistance which affects input voltage ripple of the IC. For additional input voltage filtering, a 100nF bypass capacitor can be placed in parallel with C_{IN} to shunt any high frequency noise to ground. The output capacitor, C_{OUT} , should also be placed close to the IC. Any copper trace connections for the C_{OUT} capacitor can increase the series resistance, which directly effect output voltage ripple.

The feedback network, resistor R2 should be kept close to the FB pin to minimize copper trace connections that can inject noise into the system. The ground connection for the feedback resistor network should connect directly to an analog ground plane. The analog ground plane should tie directly to the GND pin. If no analog ground plane is available, the ground connection for the feedback network should tie directly to the GND pin. Trace connections made to the inductor and Schottky diode should be minimized to reduce power dissipation and increase overall efficiency.

Package Information (SOT23-5)

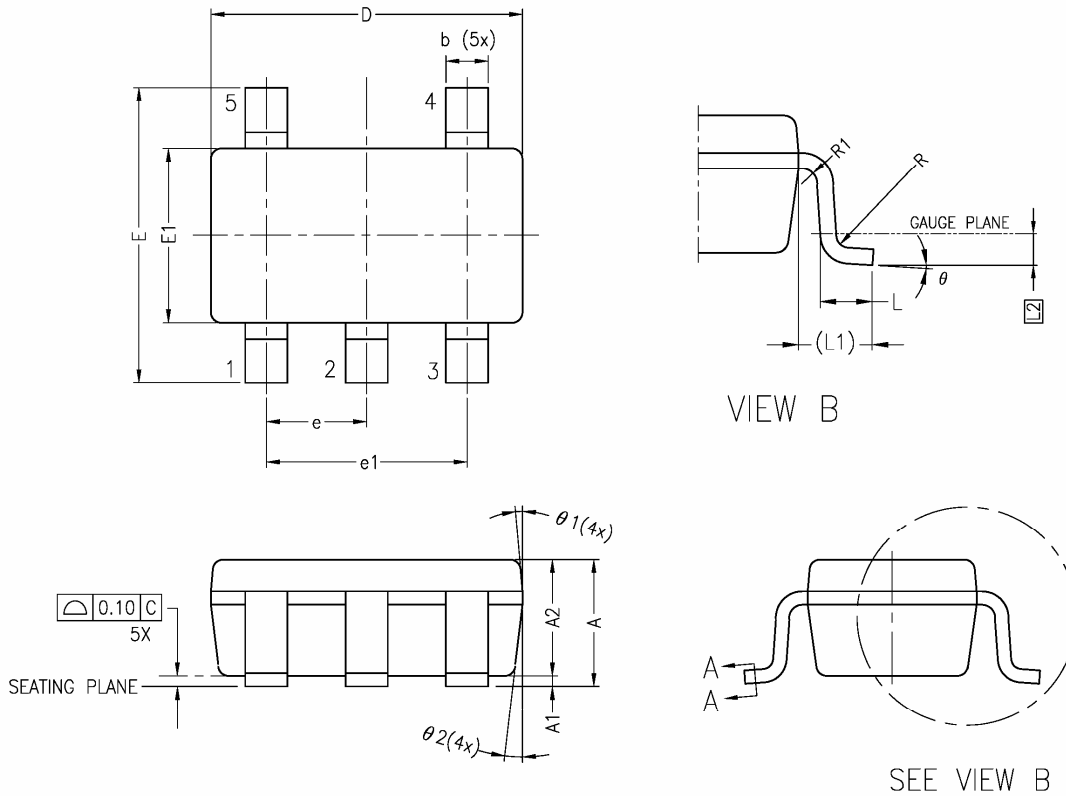

SYMBOLS	DIMENSIONS IN MILLIMETERS		
	MIN	NOM	MAX
A	1.05	1.20	1.35
A1	0.05	0.10	0.15
A2	1.00	1.10	1.20
b	0.35	—	0.50
b1	0.35	0.40	0.45
c	0.08	—	0.22
c1	0.08	0.13	0.20
D	2.80	2.90	3.00
E	2.60	2.80	3.00
E1	1.50	1.60	1.70
e	0.95 BSC		
e1	1.90 BSC		
L	0.35	0.43	0.60
L1	0.60 REF		
L2	0.25 BSC.		
R	0.10	—	—
R1	0.10	—	0.25
θ	0°	4°	8°
θ1	5°	6°	15°
θ2	5°	8°	15°

NOTICE:

- The information described herein is subject to change without notice.
- Yobon does not assume any responsibility for use of any circuitry or applications described herein, nor does it convey any patent license.