

# IMP8980D

## PCM Digital Switch

### General Description

This CMOS device is designed for switching PCM-encoded voice or data, under microprocessor control, in a modern digital exchange, PBX or Central Office. It provides simultaneous connections for up to 256 64kbit/s channels. Each of the eight serial inputs and outputs consist of 32 64kbit/s channels multiplexed to form a 2048kbit/s ST-BUS stream. In addition, the IMP8980D provides microprocessor read and write access to individual ST-BUS (Serial Telecom Bus) channels.

### Features

- ◆ ST-BUS compatible
- ◆ 8-line x 32-channel inputs
- ◆ 8-line x 32-channel outputs
- ◆ 256 ports non-blocking switch
- ◆ Single power supply (+5V)
- ◆ 30mW power consumption
- ◆ Microprocessor-control interface
- ◆ Pin-compatible with Mitel MT8980

### Functional Description

The ST-BUS architecture can be used both in software-controlled digital voice and data switching.

The ST-Bus serial streams operate continuously at 2048kbit/s and are arranged in 125 $\mu$ s wide frames which contain 32 8-bit channels.

The IMP8980D can switch data from channels on ST-BUS inputs to channels on ST-BUS outputs and simultaneously allows its controlling microprocessor to read channels on ST-BUS inputs or write to channels on ST-BUS outputs (Message Mode). To the microprocessor, the IMP8980D looks like a memory peripheral. The microprocessor can write to the IMP8980D to establish switched connections between input ST-BUS channels and output ST-BUS channels or to transmit messages on output ST-BUS channels. By reading from the IMP8980D, the microprocessor can receive messages from ST-BUS input channels or check which

Figure 1 Functional Block Diagram

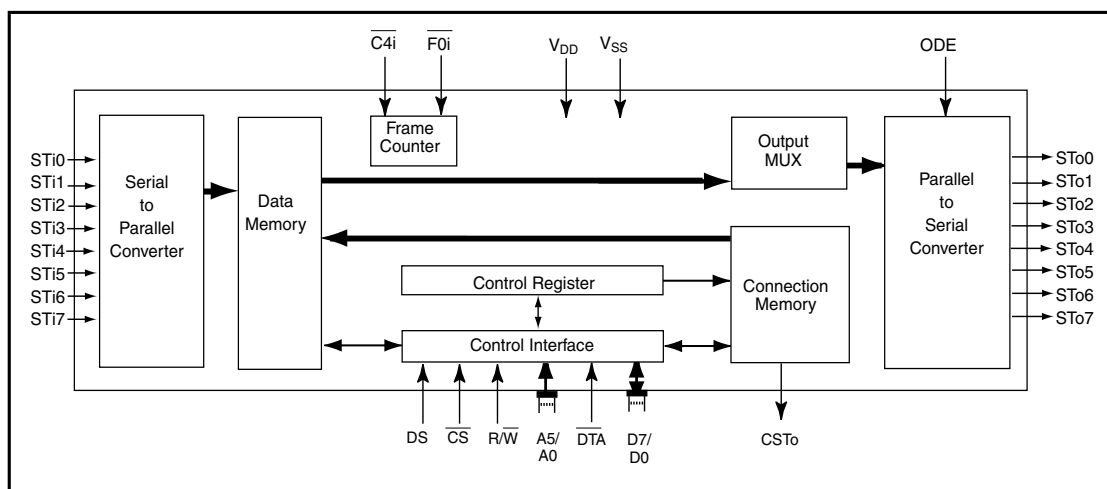

---

switched connections have already been established.

By integrating both switching and interprocessor communications, the IMP8980D allows systems to use distributed processing and to switch voice or data in an ST-BUS architecture.

### Hardware Description

Serial data at 2048 kbit/s is received at the eight ST-BUS inputs (STi0 to STi7), and serial data is transmitted at the eight ST-BUS outputs (STo0 to STo7). Each serial input accepts 32 channels of digital data, each channel containing an 8-bit word which may represent a PCM-encoded analog/voice sample as provided by a codec.

This serial input word is converted into parallel data and stored in the 256 X 8 Data Memory. Locations in the Data Memory are associated with particular channels on particular ST-BUS input streams. These locations can be read by the microprocessor which controls the chip.

Locations in the Connection Memory, which is split into high and low parts, are associated with particular ST-BUS output streams. When a channel is due to be transmitted on an ST-BUS output, the data for the channel can either be switched from an ST-BUS input or it can originate from the microprocessor. If the data is switched from an input, then the contents of the Connection Memory Low location associated with the output channel is used to address the Data Memory. This Data Memory address corresponds to the channel on the input ST-BUS stream on which the data for switching arrived. If the data for the output channel originates from the microprocessor (Message Mode), then the contents of the Connection Memory Low location associated with the output channel are output directly, and this data is output repetitively on the channel once every frame until the microprocessor intervenes.

The Connection Memory data is received, via the Control Interface, at D7 to D0. The Control Interface also receives address information at A5 to A0 and

handles the microprocessor control signals  $\overline{CS}$ ,  $\overline{DTA}$ ,  $R/\overline{W}$  and DS. There are two parts to any address in the Data Memory or Connection 2-7 Memory. The higher order bits come from the Control Register, which may be written to or read from via the Control Interface. The lower order bits come from the address lines directly.

The Control Register also allows the chip to broadcast messages on all ST-BUS outputs (i.e., to put every channel into Message Mode), or to split the memory so that reads are from the Data Memory and writes are to the Connection Memory Low. The Connection Memory High determines whether individual output channels are in Message Mode, and allows individual output channels to go into a high-impedance state, which enables arrays of IMP8980D s to be constructed. It also controls the CSto pin.

All ST-BUS timing is derived from the  $\overline{C4i}$  and  $\overline{F0i}$  signals.

### Software Control

The address lines on the Control Interface give access to the Control Register directly or, depending on the contents of the Control Register, to the High or Low sections of the Connection Memory or to the Data Memory. If address line A5 is low, then the Control Register is addressed regardless of the other address lines (see *Figure 3*). If A5 is high, then the address lines A4-A0 select the memory location corresponding to channel 0-31 for the memory and stream selected in the Control Register.

The data in the Control Register consists of mode control bits, memory select bits, and stream address bits (see *Figure 4*). The memory select bits allow the Connection Memory High or Low or the Data Memory to be chosen, and the stream address bits define one of the ST-BUS input or output streams.

Bit 7 of the Control Register allows split memory operation - reads are from the Data Memory and writes are to the Connection Memory Low.

The other mode control bit, bit 6, puts every output channel on every output

stream into active Message Mode; i.e., the contents of the Connection Memory Low are output on the ST-BUS output streams once every frame unless the ODE pin is low. In this mode the chip behaves as if bits 2 and 0 of every Connection Memory High location were 1, regardless of the actual values.

If bit 6 of the Control Register is 0, then bits 2 and 0 of each Connection Memory

High location function normally (see *Figure 5*). If bit 2 is 1, the associated ST-BUS output channel is in Message Mode; i.e., the byte in the corresponding Connection Memory Low location is transmitted on the stream at that channel. Otherwise, one of the bytes received on the serial inputs is transmitted and the contents of the Connection Memory Low define the ST-BUS input stream and channel where the byte is to be found (see *Figure 6*).

Figure 3- Address Memory Map

A5	A4	A3	A2	A1	A0	HEX ADDRESS	LOCATION
0	X	X	X	X	X	00-1F	Control Register*
1	0	0	0	0	0	20	Channel 0†
1	0	0	0	0	1	21	Channel 1†
•	•	•	•	•	•	•	•
•	•	•	•	•	•	•	•
•	•	•	•	•	•	•	•
1	1	1	1	1	1	3F	Channel 31†

\* Writing to the Control Register is the only fast transaction.

† Memory and stream are specified by the contents of the Control Register.

Figure 4 - Control Register Bits

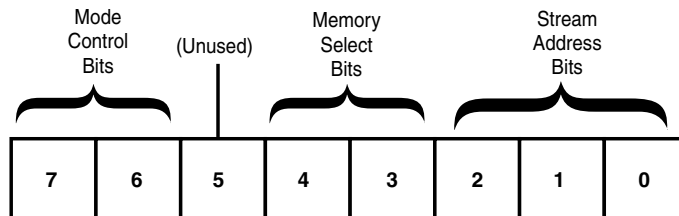

BIT	NAME	DESCRIPTION
7	Split Memory	When 1, all subsequent reads are from the Data Memory and writes are to the Connection Memory Low, except when the Control Register is accessed again. When 0, the Memory Select bits specify the memory for subsequent operations. In either case, the Stream Address Bits select the subsection of the memory which is made available.
6	Message Mode	When 1, the contents of the Connection Memory Low are output on the Serial Output streams except when the ODE pin is low. When 0, the Connection Memory bits for each channel determine what is output.
5	(unused)	
4-3	Memory Select Bits	0-0 - Not to be used 0-1 - Data Memory (read only from the microprocessor port) 1-0 - Connection Memory Low 1-1 - Connection Memory High
2-0	Stream Address Bits	The number expressed in binary notation on these bits refers to the input or output ST-BUS stream which corresponds to the subsection of memory made accessible for subsequent operations.

Figure5 - Connection Memory High Bits

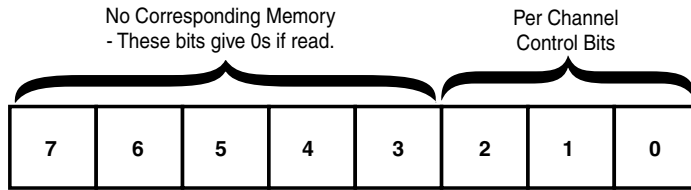

BIT	NAME	DESCRIPTION
2	Message Channel	When 1, the contents of the corresponding location in Connection Memory Low are output on the location's channel and stream. When 0, the contents of the corresponding location in Connection Memory Low act as an address for the Data Memory and so determine the source of the connection to the location's channel and stream.
1	CSTo	This bit is output on the CSTo pin one channel early. The CSTo bit for stream 0 is output first.
0	Output Enable	If the ODE pin is high and bit 6 of the Control Register is 0, then this bit enables the output driver for the location's channel and stream. This allows individual channels on individual streams to be made high-impedance, allowing switching matrices to be constructed. A "1" enables the driver and a "0" disables it.

If the ODE pin is low, then all serial outputs are high-impedance. If it is high and bit 6 in the Control Register is 1, then all outputs are active. If the ODE pin is high and bit 6 in the Control Register is 0, then the bit 0 in the Connection Memory High location enables the output drivers for the corresponding individual ST-BUS output stream and channel. Bit 0=1 enables the driver and bit 0=0 disables it (see *Figure 5*).

Bit 1 of each Connection Memory High location (see *Figure 5*) is output on the CSTo pin once every frame. To allow for delay in any external control circuitry the bit is output one channel before the corresponding channel on the ST-BUS streams, and the bit for stream 0 is output first in the channel; e.g., bit 1's for channel 9 of streams 0-7 are output synchronously with ST-BUS channel 8 bits 7-0.

## Applications

### Digital Switching Systems

*Figures 7 and 8* show how IMP8980Ds and MT8964s form a simple digital switching system. *Figure 7* shows the

interface between the IMP8980D's and the filter/codecs. *Figure 8* shows the position of these components in an example architecture.

The Mitel MT8964 filter/codec in *Figure 7* receives and transmits digitized voice signals on the ST-BUS input DR, and ST-BUS output DX, respectively. These signals are routed to the ST-BUS inputs and outputs on the top IMP8980D, which is used as a digital speech switch.

The MT8964 is controlled by the ST-BUS input DC originating from the bottom IMP8980D, which generates the appropriate signals from an output channel in Message Mode. This architecture optimizes the messaging capability of the line circuit by building signalling logic, e.g., for on-off hook detection, which communicates on an ST-BUS output. This signalling ST-BUS output is monitored by a microprocessor (not shown) through an ST-BUS input on the bottom IMP8980D.

*Figure 8* shows how a simple digital switching system may be designed using the ST-BUS architecture. This is a private telephone network with 256 extensions which uses a single IMP8980D as a speech

switch and a second IMP8980D for communication with the line interface circuits.

A larger digital switching system may be designed by cascading a number of IMP8980Ds. *Figure 9* shows four IMP8980Ds arranged in a non-blocking configuration which can switch any channel on any of the ST-BUS inputs to any channel on the ST-BUS outputs.

### Application Circuit with 6802 Processor

*Figure 10* shows an example of a complete circuit which may be used to evaluate the chip.

For convenience, a 4MHz crystal oscillator has been used rather than a 4.096MHz clock, as both are within the limits of the chip's specifications. The RC delay used with the 393 counters ensures a sufficient hold time for the FP signal, but the values used may have to be changed if faster 393 counters become available. The chip is shown as memory mapped into the MEK6802D3 system. Chip addresses 00-3F correspond to processor addresses 2000-203F. Delay through the address decoder requires the VMA signal to be used twice to remove glitches. The MEK6802D3 board uses a 10KΩ pullup on the MR pin, which would have to be incorporated into the circuit if the board was replaced by a processor.

*Figure 6 - Connection Memory Low Bits*

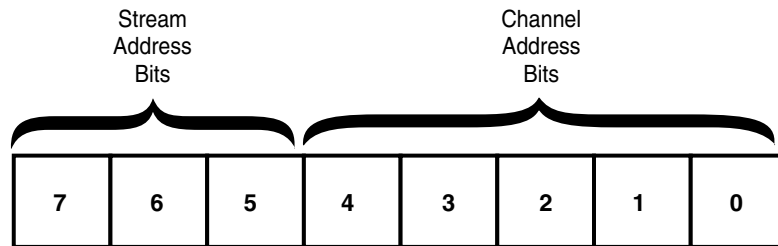

BIT	NAME	DESCRIPTION
7-5*	Stream * Address Bits	The number expressed in binary notation on these 3 bits is the number of the ST-BUS stream for the source of the connection. Bit 7 is the most significant bit. e.g., if bit 7 is 1, bit 6 is 0 and bit 5 is 0, then the source of the connection is a channel on STi4.
4-0*	Channel Address Bits*	The number expressed in binary notation on these 5 bits is the number of the channel which is the source of the connection (The ST-BUS stream where the channel lies is defined by bits 7, 6 and 5.). Bit 4 is the most significant bit. e.g., if bit 4 is 1, bit 3 is 0, bit 2 is 0, bit 1 is 1 and bit 0 is 1, then the source of the connection is channel 19.

\* If bit 2 of the corresponding Connection High location is 1 or if bit 6 of the Control Register is 1, then the entire 8 bits are output on the channel and stream associated with this location. Otherwise, the bits are used as indicated to define the source of the connection which is output on the channel and stream associated with this location.

Figure 7 Typical Simple Digital Switching System

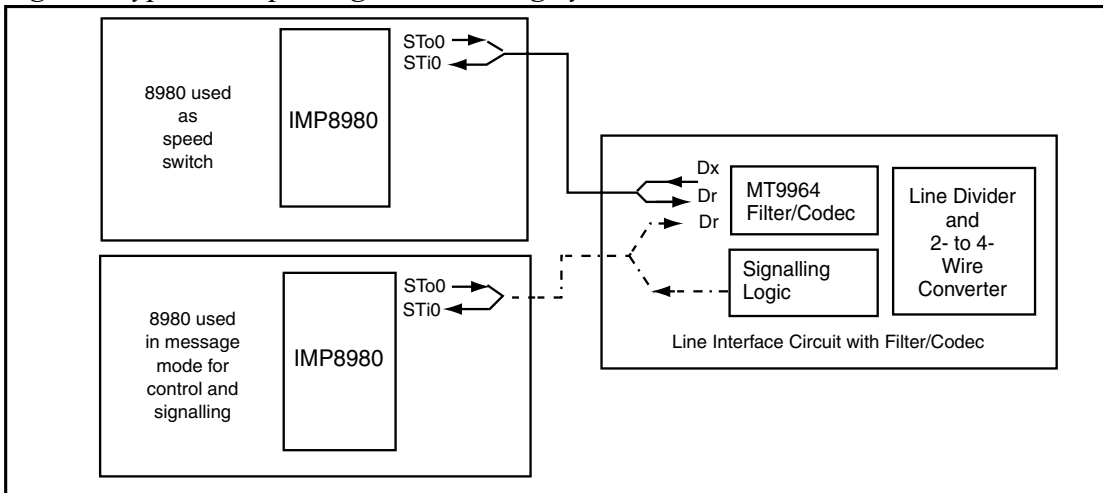

Figure 8 Simple Digital Switching System

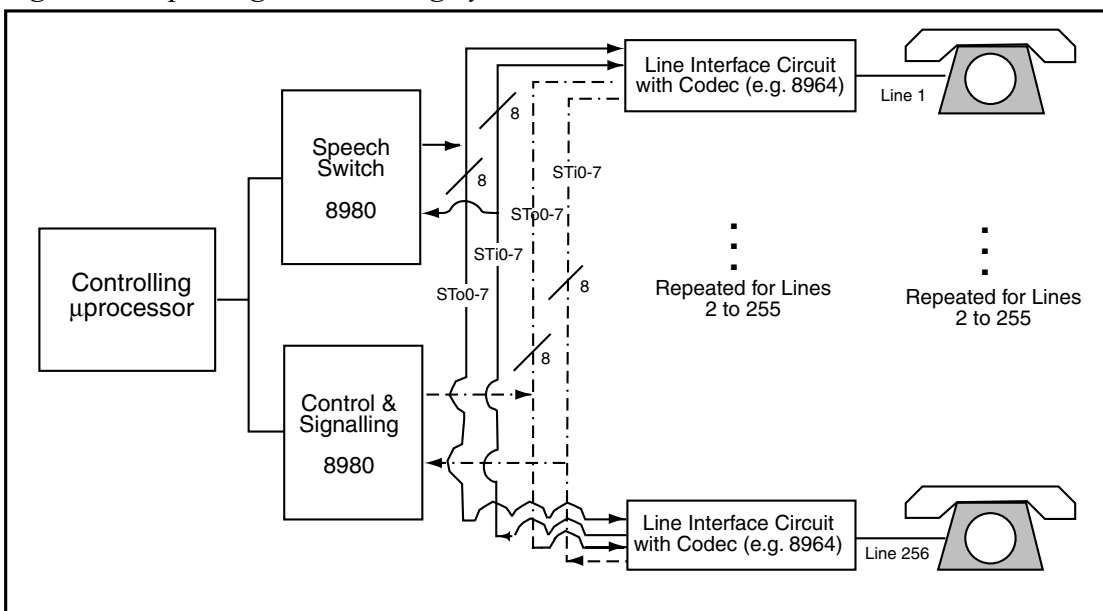

Figure 9 Non-Blocking 16x16 Switch

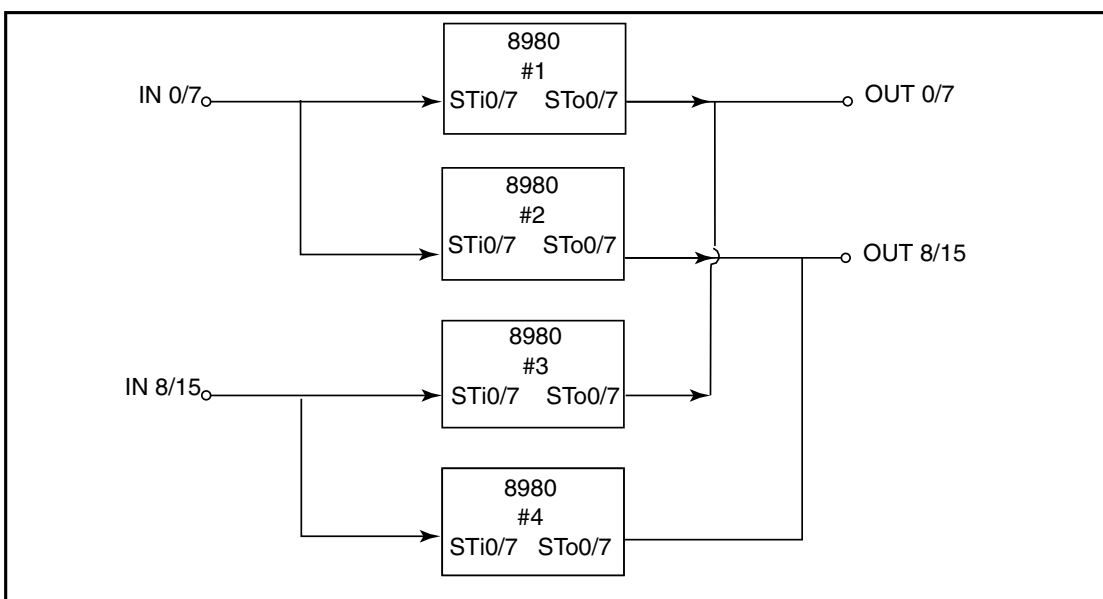
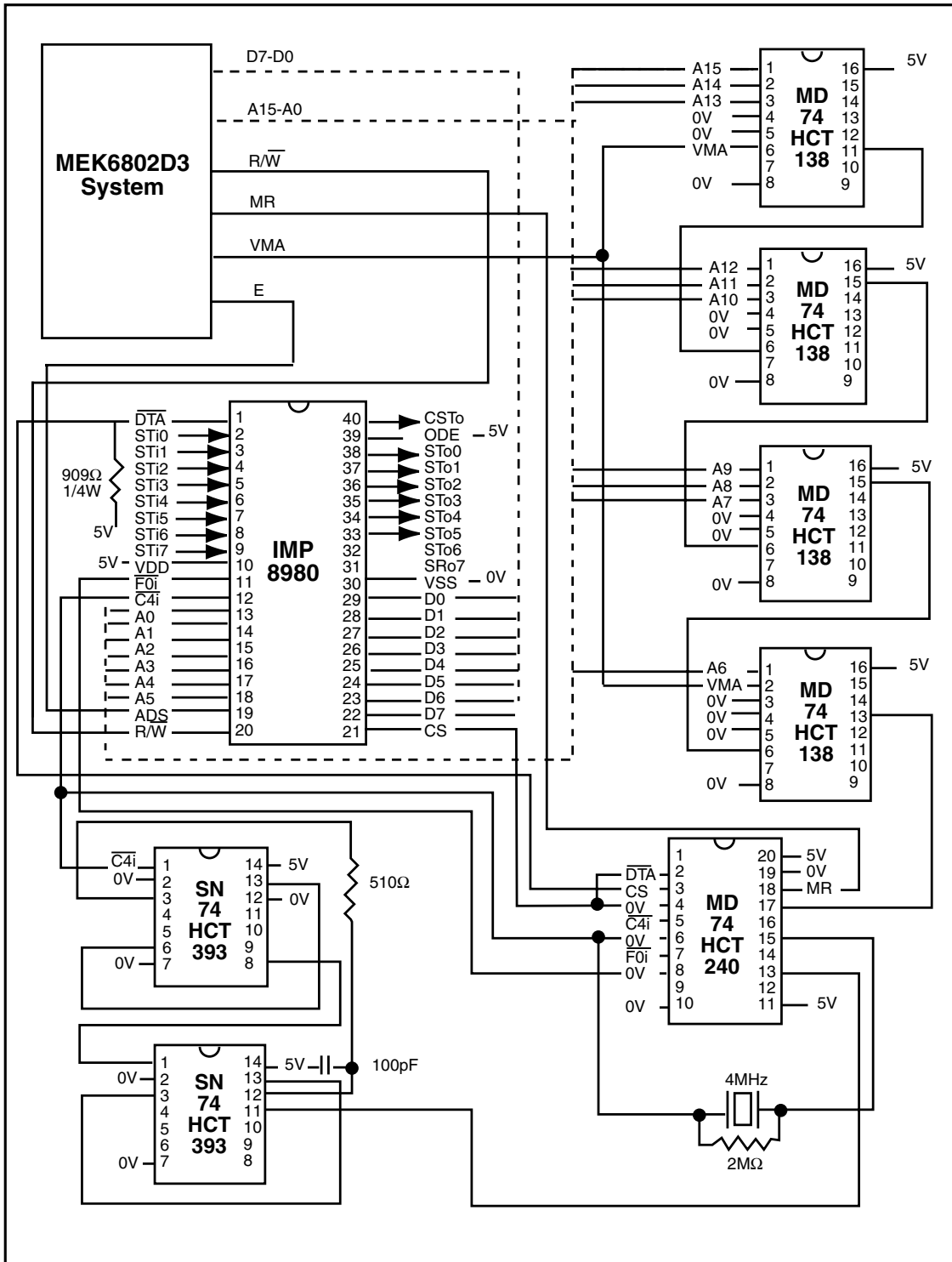

Figure 10 Application Circuit



### Absolute Maximum Ratings\*

	Parameter	Symbol	Min	Max	Units
1	$V_{DD} - V_{SS}$		-0.3	7	V
2	Voltage on Digital Inputs	$V_I$	$V_{SS}-0.3$	$V_{DD}+0.3$	V
3	Voltage on Digital Outputs	$V_O$	$V_{SS}-0.3$	$V_{DD}+0.3$	V
4	Current at Digital Outputs	$I_O$		40	mA
5	Storage Temperature	$T_S$	-65	+150	°C
6	Package Power Dissipation	$P_D$		2	W

\* Exceeding these values may cause permanent damage. Functional operation under these conditions is not implied.

### Recommended Operating Conditions - Voltages are with respect to ground ( $V_{SS}$ ) unless otherwise stated.

	Characteristics	Sym	Min	Typ ‡	Max	Units	Test Conditions
1	Operating Temperature	$T_{OP}$	-40		+85	°C	
2	Positive Supply	$V_{DD}$	4.75		5.25	V	
3	Input Voltage	$V_I$	0		$V_{DD}$	V	

‡ Typical figures are at 25°C and are for design aid only: not guaranteed and not subject to production testing.

### DC Electrical Characteristics - Voltages are with respect to ground ( $V_{SS}$ ) unless otherwise stated.

	Characteristics	Sym	Min	Typ ‡	Max	Units	Test Conditions
<b>Inputs</b>							
1	Supply Current	$I_{DD}$		6	10	mA	Outputs unloaded
2	Input High Voltage	$V_{IH}$	2.0			V	
3	Input Low Voltage	$V_{IL}$			0.8	V	
4	Input Leakage	$I_{IL}$			5	μA	$V_I$ between $V_{SS}$ and $V_{DD}$
5	Input Pin Capacitance	$C_I$		8		pF	
<b>Outputs</b>							
6	Output High Voltage	$V_{OH}$	2.4			V	$I_{OH} = 10$ mA
7	Output High Current	$I_{OH}$	10	15		mA	Sourcing. $V_{OH}=2.4$ V
8	Output Low Voltage	$V_{OL}$			0.4	V	$I_{OL} = 5$ mA
9	Output Low Current	$I_{OL}$	5	10		mA	Sinking. $V_{OL} = 0.4$ V
10	High Imp. Leakage	$I_{OZ}$			5	μA	$V_O$ between $V_{SS}$ and $V_{DD}$
11	Output Pin Capacitance	$C_O$		8		pF	

‡ Typical figures are at 25°C and are for design aid only: not guaranteed and not subject to production testing.

Figure 11 Output Load Test

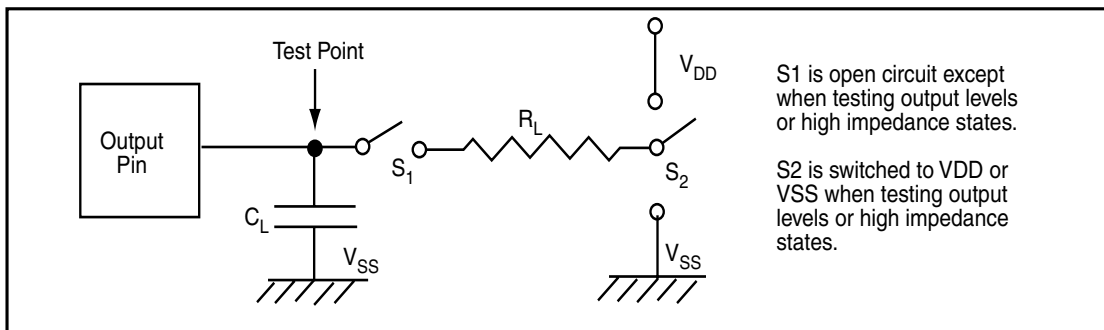



### AC Electrical Characteristics † - Clock Timing (Figures 12 and 13)

	Characteristics	Sym	Min	Typ ‡	Max	Units	Test Conditions
1	Clock Period*	t <sub>CLK</sub>	220	244	300	ns	
2	Clock Width High	t <sub>CH</sub>	95	122	150	ns	
3	Clock Width Low	t <sub>CL</sub>	110	122	150	ns	
4	Clock Transition Time	t <sub>CTT</sub>		20		ns	
5	Frame Pulse Setup Time	t <sub>CTT</sub>		20		ns	
6	Frame Pulse Hold Time	t <sub>FPH</sub>	0.020		670	µs	
7	Frame Pulse Width	t <sub>FPW</sub>		244		ns	

†† Timing is over recommended temperature & power supply voltages.

‡ Typical figures are at 25°C and are for design aid only; not guaranteed and not subject to production testing.

\* Contents of Connection Memory are not lost if the clock stops, however, ST-BUS outputs go into the high impedance state. NB: Frame Pulse is repeated every 512 cycles of C4i.

Figure 12 Frame Alignment

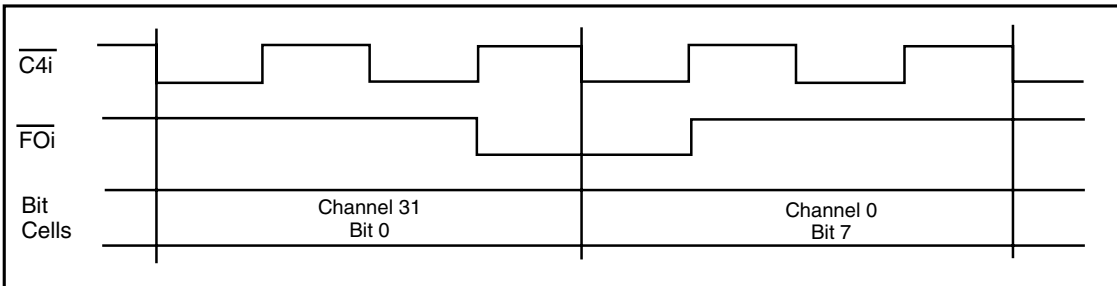
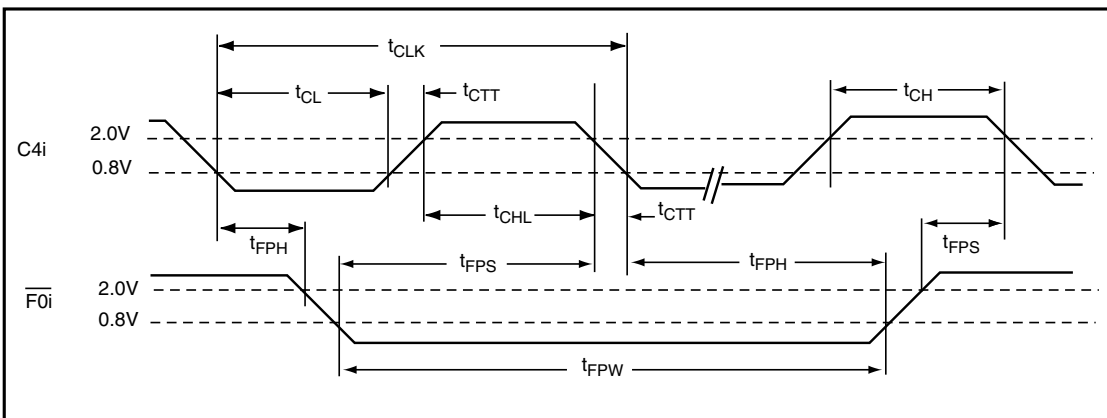

Figure 13 Clock Timing



### AC Electrical Characteristics † - Serial Streams (Figures 11, 14, 15 and 16)

	Characteristics	Sym	Min	Typ ‡	Max	Units	Test Conditions
<b>Inputs</b>							
1	STo0/7 Delay-Active to High Z	tsAZ	20	50	80	ns	$R_L=1\text{ K}\Omega^*$ , $C_L=150\text{ pF}$
2	STo0/7 Delay-High Z to Active	tsZA	25	60	125	ns	$C_L=150\text{ pF}$
3	STo0/7 Delay-Active to Active	tsAA	30	65	125	ns	$C_L=150\text{ pF}$
4	STo0/7 Hold Time	tSOH	25	45		ns	$C_L=150\text{ pF}$
5	Output Driver Enable Delay	toED		45	125	ns	$R_L=1\text{ K}\Omega^*$ , $C_L=150\text{ pF}$
6	External Control Hold Time	txCH	0	50		ns	$C_L=150\text{ pF}$
7	External Control Delay	txCD		75	110	ns	$C_L=150\text{ pF}$
<b>Outputs</b>							
8	Serial Input Setup Time	tsis		-40	-20	ns	
9	Serial Input Hold Time	tsih	90			ns	

† Timing is over recommended temperature & power supply voltages.

‡ Typical figures are at 25°C and are for design aid only: not guaranteed and not subject to production testing.

\* High Impedance is measured by pulling to the appropriate rail with  $R_L$ , with timing corrected to cancel time taken to discharge  $C_L$ .

Figure 14 Serial Outputs and External Control

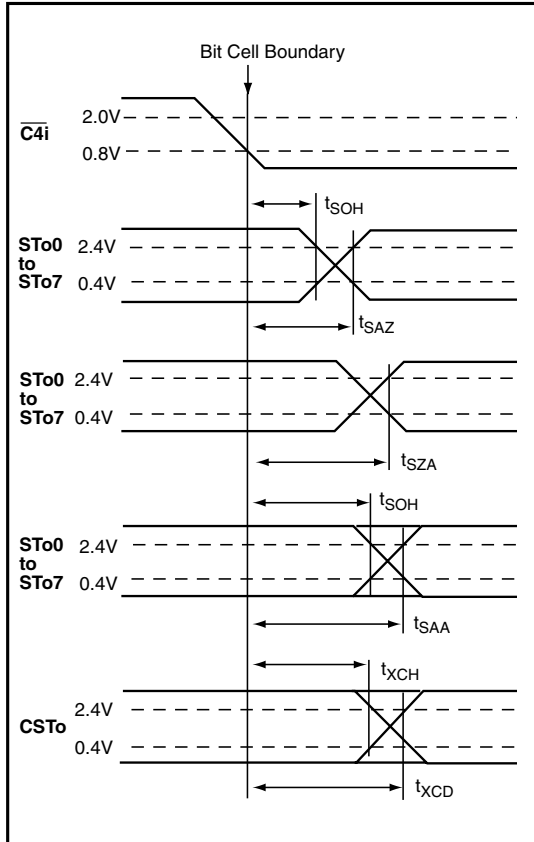

Figure 15 Output Driver Enable

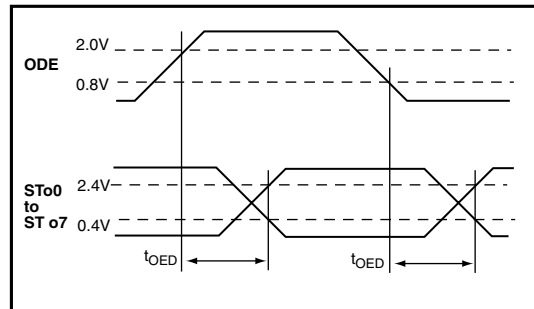
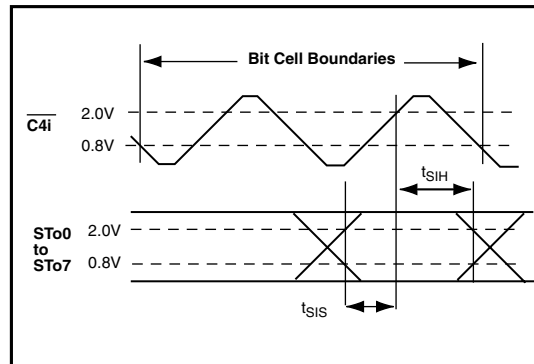

Figure 16 Serial Inputs



### AC Electrical Characteristics † - Processor Bus (Figures 11 and 17)

	Characteristics	Sym	Min	Typ ‡	Max	Units	Test Conditions
1	Chip Select Setup Time	$t_{CSS}$	20	0		ns	
2	Read/Write Setup Time	$t_{RWS}$	25	5		ns	
3	Address Setup Time	$t_{ADS}$	25	5		ns	
4	Acknowledgement Delay	Fast	$t_{AKD}$	40	100	ns	$C_L=150\text{ pF}$ $\overline{C4i}$ cycles ①
		Slow	$t_{AKD}$	2.7	7.2	cycles	
5	Fast Write Data Setup Time	$t_{FWS}$	20			ns	
6	Slow Write Data Delay	$t_{SWD}$		2.0	1.7	cycles	$\overline{C4i}$ cycles ①
7	Read Data Setup Time	$t_{RDS}$			0.5	cycles	$\overline{C4i}$ cycles ①, $C_L=150\text{ pF}$
8	Data Hold Time	Read	$t_{DHT}$	20		ns	$R_L=1\text{ K}\Omega^*$ , $C_L=150\text{ pF}$
		Write	$t_{DHT}$	20	10	ns	
9	Read Data To High Imp.	$t_{RDZ}$		50	90	ns	$R_L=1\text{ K}\Omega^*$ , $C_L=150\text{ pF}$
10	Chip Select Hold Time	$t_{CSH}$	0			ns	
11	Read/Write Hold Time	$t_{RWH}$	0			ns	
12	Address Hold Time	$t_{ADH}$	0			ns	
13	Acknow. Hold Time	$t_{AKH}$	10	60	80	ns	$R_L=1\text{ K}\Omega^*$ , $C_L=150\text{ pF}$

† Timing is over recommended temperature & power supply voltages.

‡ Typical figures are at 25°C and are for design aid only: not guaranteed and not subject to production testing.

\* High Impedance is measured by pulling to the appropriate rail with  $R_L$ , with timing corrected to cancel time taken to discharge  $C_L$ .

① Processor accesses are dependent on the  $\overline{C4i}$  clock, and so some timings are expressed as multiples of the  $\overline{C4i}$  clock period.

Figure 17 Processor Bus

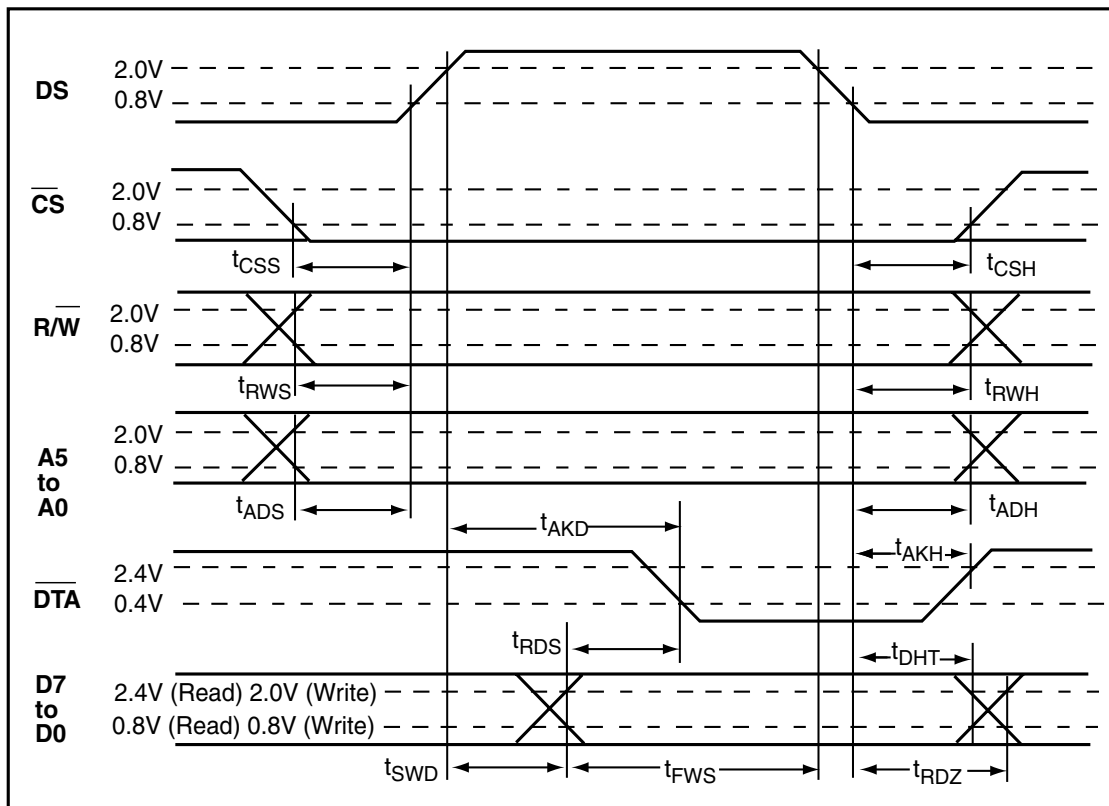

## Pin Description

Pin #		Name	Description
40 DIP	44 PLCC		
1	2	$\overline{\text{DTA}}$	<b>Data Acknowledgement (Open Drain Output).</b> This is the data acknowledgement on the microprocessor interface. This pin is pulled low to signal that the chip has processed the data. A 909 $\Omega$ , 1/4W, resistor is recommended to be used as a pullup.
2 -4	3 -5	STi0 -STi2	<b>ST-BUS Input 0 to 2 (Inputs).</b> These are the inputs for the 2048 kbit/s ST-BUS input streams.
5 -9	7 -11	STi3 -STi7	<b>ST-BUS Input 3 to 7 (Inputs).</b> These are the inputs for the 2048 kbit/s ST-BUS input streams.
10	12		<b>VDD Power Input.</b> Positive Supply.
11	13	$\overline{\text{FOi}}$	<b>Framing 0-Type (Input).</b> This is the input for the frame synchronization pulse for the 2048 kbit/s ST-BUS streams. A low on this input causes the internal counter to reset on the next negative transition of C4i
12	14	$\overline{\text{C4i}}$	<b>4.096 MHz Clock (Input).</b> ST-BUS bit cell boundaries lie on the alternate falling edges of this clock.
13 -15	15 -17	A0 -A2	<b>Address 0 to 2 (Inputs).</b> These are the inputs for the address lines on the microprocessor interface.
16 -18	19 -21	A3 -A5	<b>Address 3 to 5 (Inputs).</b> These are the inputs for the address lines on the microprocessor interface.
19	22	DS	<b>Data Strobe (Input).</b> This is the input for the active high data strobe on the microprocessor interface.
20	23	$\overline{\text{R/W}}$	<b>Read or Write (Input).</b> This is the input for the read/write signal on the microprocessor interface - high for read, low for write.
21	24	$\overline{\text{CS}}$	<b>Chip Select (Input).</b> This is the input for the active low chip select on the microprocessor interface
22 -24	25 -27	D7 -D5	<b>Data 7 to 5 (Three-state I/O Pins).</b> These are the bidirectional data pins on the microprocessor interface.
25 -29	29 -33	D4 -D0	<b>Data 4 to 0 (Three-state I/O Pins).</b> These are the bidirectional data pins on the microprocessor interface.
30 31 -35	34 35 -39	Vss STo7 -STO3	<b>Power Input.</b> Negative Supply (Ground). <b>ST-BUS Output 7 to 3 (Three-state Outputs).</b> These are the pins for the eight 2048 kbit/s ST-BUS output streams.
36 -38	41 -43	STo2 -STo0	<b>ST-BUS Output 2 to 0 (Three-state Outputs).</b> These are the pins for the eight 2048 kbit/s ST-BUS output streams.
39	44	ODE	<b>Output Drive Enable (Input).</b> If this input is held high, the STo0-STo7 output drivers function normally. If this input is low, the STo0-STo7 output drivers go into their high impedance state. NB: Even when ODE is high, channels on the STo0-STo7 outputs can go high impedance under software control.
40	1	CSTo	<b>Control ST-BUS Output (Complementary Output).</b> Each frame of 256 bits on this ST-BUS output contains the values of bit 1 in the 256 locations of the Connection Memory High.
	6, 18, 28, 40	NC	No Connection.

Figure 2 Pin Connections

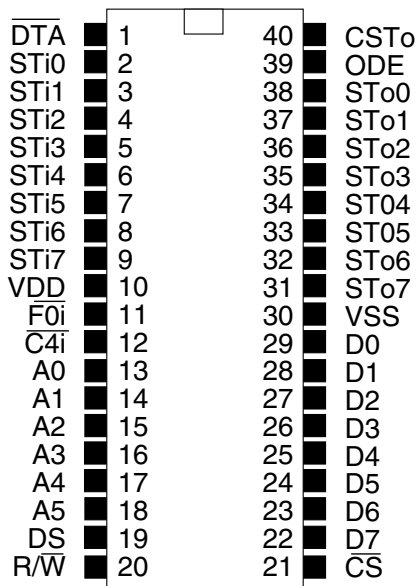
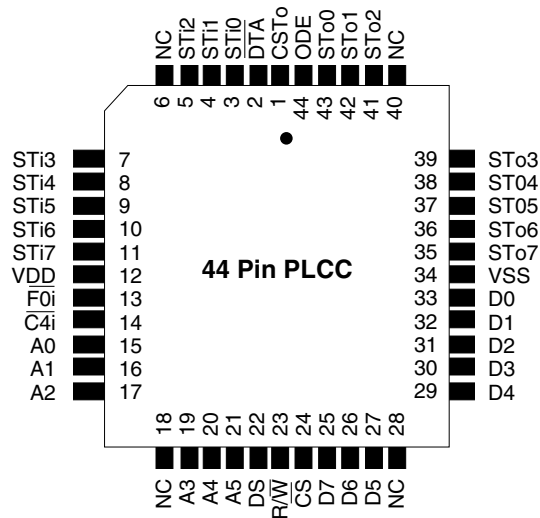

**40 Pin CERDIP/Plastic DIP**

**Ordering Information**

Ordering Part Number	Package Type
IMP8980DC	40 Pin Ceramic DIP
IMP8980DE	40 Pin Plastic DIP
IMP8980DP	44 Pin PLCC
IMP8980DP/T	Tape and Reel, 44 Pin PLCC



*ISO 9001 Registered*

**IMP, Inc.**

Corporate Headquarters

2830 N. First Street

San Jose, CA 95134

Tel: 408.432.9100 Main

Tel: 800.434.3722

Fax: 408.434.0335

e-mail: [info@impinc.com](mailto:info@impinc.com)

*<http://www.impweb.com>*

Information furnished by IMP, Inc. is believed to be accurate and reliable. No responsibility is assumed by IMP for use of this product nor for any infringements of patents or trademarks or other rights of third parties resulting from its use. IMP reserves the right to make changes in specifications at any time without notice. IMP does not authorize or warrant any IMP products for use in life support devices and/or systems without the expressed written approval of an officer of IMP, Inc.

The IMP logo is a registered trademark of IMP, Inc.

All other company and product names are trademarks of their respective owners.

© 2000 IMP, Inc.

Printed in USA

Part No.:

Document Number: IMP8980D DS 05/00