

DESCRIPTION

The IP1523 is a dual output voltage series regulator with output on/off control function. The nominal output voltages are 3.3V and 2.0V, respectively. The 3.3V regulator can provide the output current up to 550mA. While the 2.0V regulator can provide up to 500mA. When the IP1523 becomes off, all the output voltages are shut down.

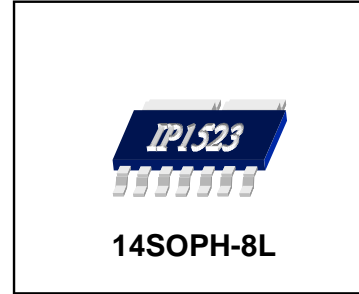

FEATURES

- 1-Fixed 3.3V Regulator with Internal NPN TR.
- 1-Fixed 2.0V Regulator with Internal NPN TR.
- Built-in TSD circuit.
- Built-in Current Limit Circuit.
- Built-in ON/OFF Control Circuit.
- Built-in Over Voltage Protection Circuit.
- Outputs Trimmed to +/-3% Tolerance

ORDERING INFORMATION

Device	Package	Operating Temp
IP1523	14SOPH-8L	-35°C ~ +85°C

BLOCK DIAGRAM

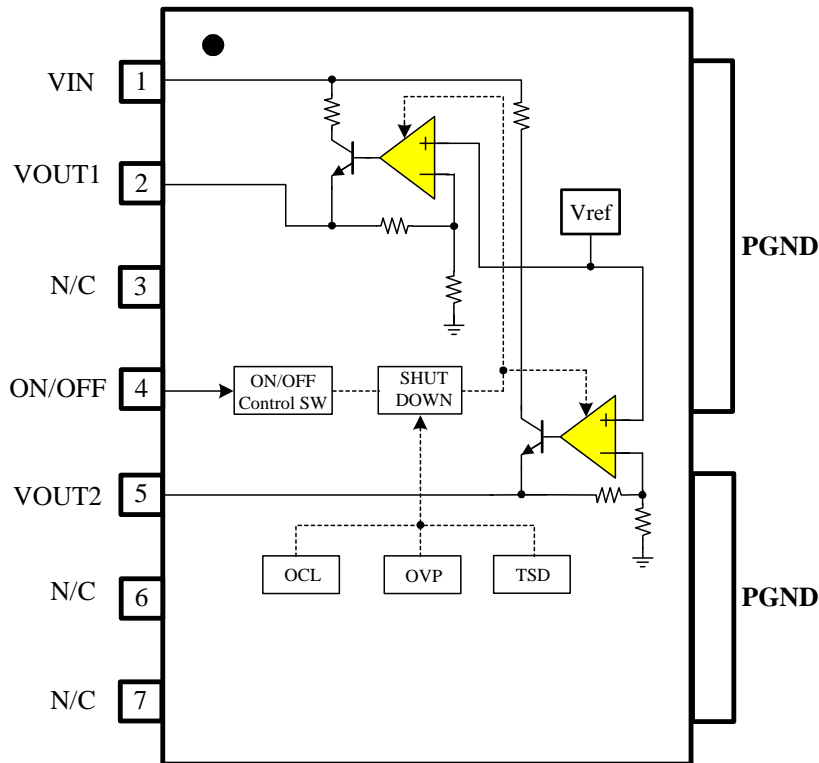

PIN CONNECTIONS

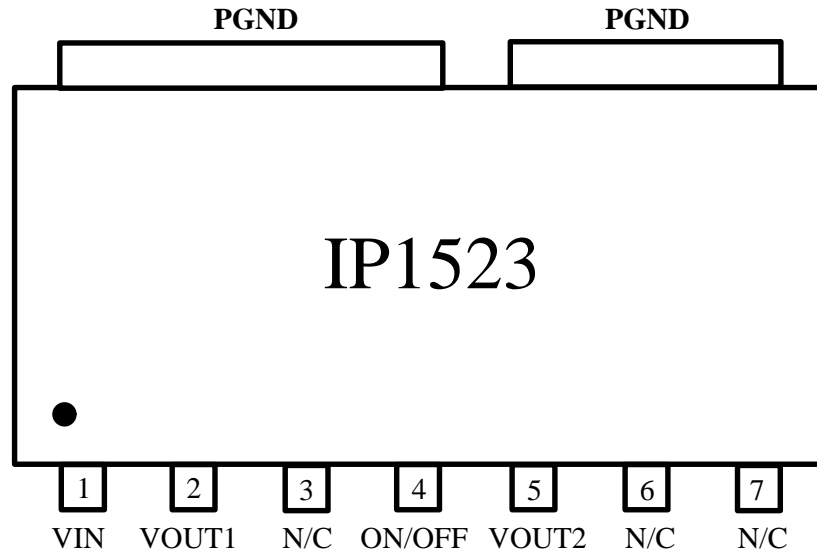

PIN DESCRIPTIONS

NO	SYMBOL	I/O	DESCRIPTION
1	VIN	I	Input Supply Voltage
2	VOUT1	O	Reg +3.3V Output
3	N/C	-	No Connection
4	ON/OFF	I	ON/OFF Control
5	VOUT2	O	Reg +2.0V Output
6	N/C	-	No Connection
7	N/C	-	No Connection
8	PGND	-	Power Ground

ABSOLUTE MAXIMUM RATINGS(TA=25°C)

CHARACTERISTICS	SYMBOL	VALUE	UNIT
Maximum supply voltage	Vinmax	10	V
ON/OFF voltage	Vonoff	10	V
Power dissipation	Pd	3.5*	W
Operating temperature	Topr	-35 ~ +85	°C
Storage temperature	Tstr	-55 ~ +150	°C
Maximum output current	Iomax	700	mA

Note>

1. When mounted on 100mm X 100mm X 1mm PCB (Phenolic resin material).
2. Power dissipation reduces 28mW/°C for using above Ta=25°C
3. Do not exceed Pd and SOA.

POWER DISSIPATION CURVE

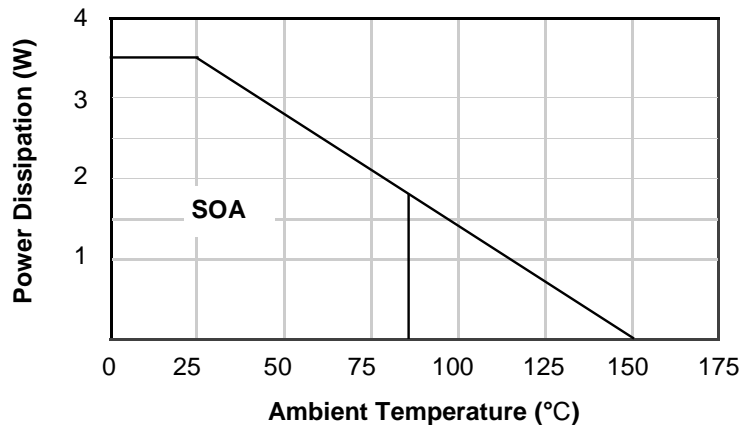

RECOMMENDED OPERATING CONDITIONS

CHARACTERISTICS	SYMBOL	VALUE	UNIT
Supply voltage	Vcc	4.5 ~ 6.0	V
Input voltage	Vin	4.5 ~ 6.0	V

ELECTRICAL CHARACTERISTICS

($V_{in}=5.25V$, $C_o=10\mu F$, $T_a=25^\circ C$, unless otherwise specified.)

Characteristics	Symbol	Condition	Min.	Typ.	Max.	Units
Quiescent current	I _{cc}	V _{cc} =5.25V, No-Load	-	7	12	mA
OVP Detecting Voltage	V _{ovp}	V _{cc} =Variable	6.5	-	-	V
3.3V REGULATOR PART						
Output Voltage	V _{out1}	I _o =10mA	3.2	3.3	3.4	V
Line Regulation	dV _{line1}	V _{in} =4.5~6V, I _o =10mA	-	0.035	0.2	%
Load Regulation	dV _{load 1}	V _{in} =5.25V, 10mA < I _o < 500mA	-	0.4	0.8	%
Dropout voltage	V _{drop1}	I _o =500mA	-	1.1	1.3	V
Ripple rejection	RR1	F=120Hz, C _o =10 μ F Tantalum (V _{in} -V _{out})=3V, I _o =200mA	60	70	-	dB
Current limit ^{*Note}	I _{limit1}	V _{in} -V _{out} =2.5V	550	-	-	mA
Temperature stability	Temp1	-	-	0.5	-	%
Output noise voltage 1	V _{n1}	I _o =300mA	-	100	-	μ V
2.0V REGULATOR PART						
Output Voltage	V _{out2}	I _o =10mA	1.94	2.0	2.06	V
Line Regulation	dV _{line2}	V _{in} =4.5~6V, I _o =10mA	-	0.035	0.2	%
Load Regulation	dV _{load2}	V _{in} =5.25V, 10mA < I _o < 300mA	-	0.4	0.8	%
Dropout voltage	V _{drop2}	I _o =300mA	-	1.7	2.1	V
Ripple rejection	RR2	F=120Hz, C _o =10 μ F Tantalum (V _{in} -V _{out})=3V, I _o =100mA	60	70	-	dB
Current limit ^{*Note}	I _{limit2}	V _{in} -V _{out} =3.0V	500	-	-	mA
Temperature stability	Temp2	-	-	0.5	-	%
Output noise voltage 2	V _{n2}	I _o =150mA	-	100	-	μ V

ELECTRICAL CHARACTERISTICS (Continued)

($V_{in} = 5.25V$, $C_o = 10\mu F$, $T_a = 25^\circ C$, unless otherwise specified.)

Parameter	Symbol	Condition	Min.	Typ.	Max.	Units
ON/OFF CONTROL PART						
On voltage	V_{on}	$V_{out} = \text{Enabled}$	-	-	0.8	V
Off voltage	V_{off}	$V_{out} = \text{Disabled}$	2.0	-	-	V

* Note

Don't exceed following the current limit.

($I_{out1} : 550 \text{ mA}$, $I_{out2} : 500 \text{ mA}$)

APPLICATION SUMMARY

- ON / OFF Control Function

If you want to control the output of the IP1523, use pin #4 as follows:

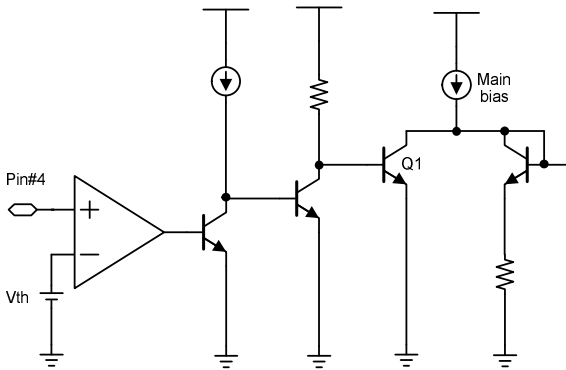

ON/OFF control function

Pin#4	IP1523
HIGH	off
LOW	on

If the voltage of pin#4 becomes larger than the threshold voltage V_{th} , the main bias current and hence, the output voltages will be shut down.

TYPICAL APPLICATION CIRCUIT

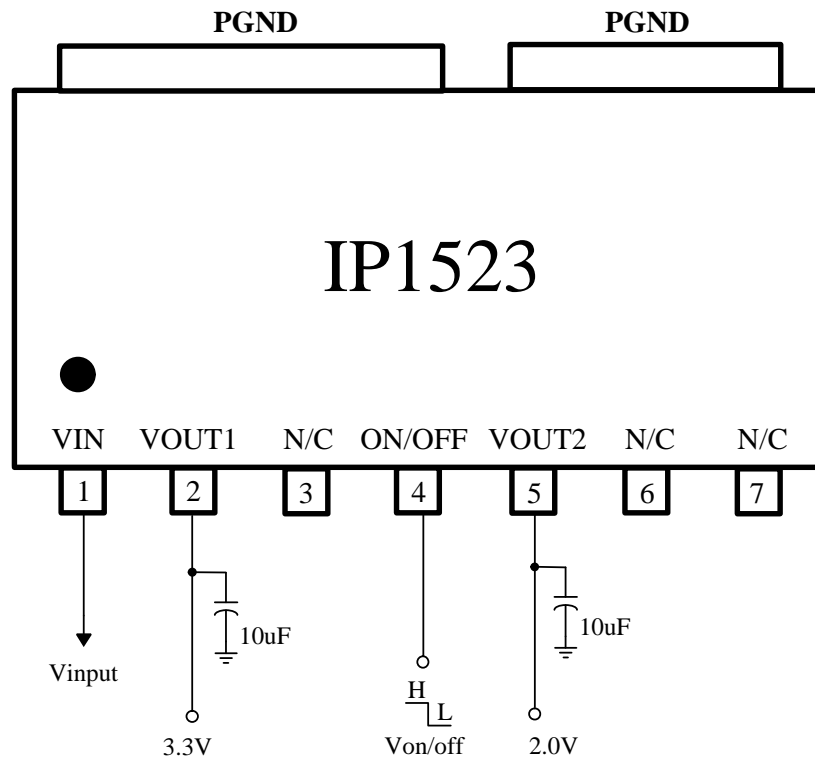

INTERNAL CIRCUIT

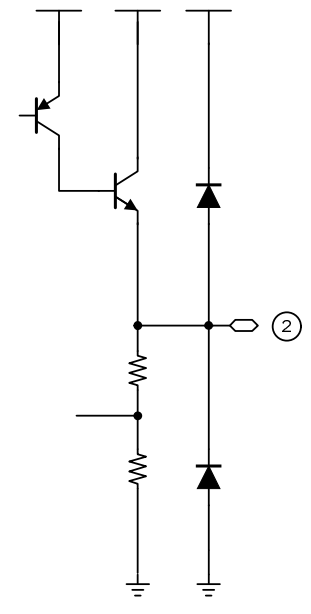
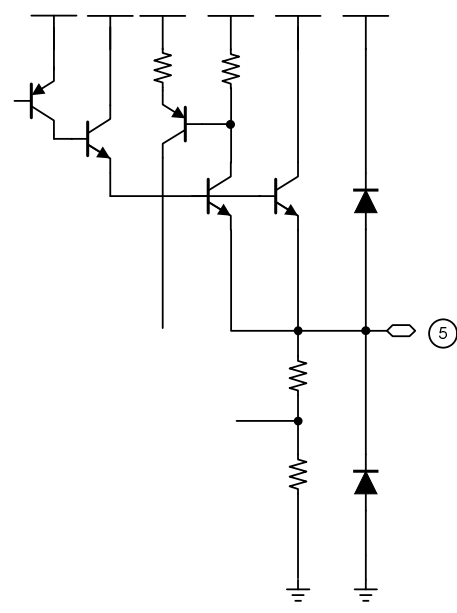
Pin no	Pin name	Internal circuit
2	Regulator output1	
5	Regulator Output2	

INTERNAL CIRCUIT (Continued)

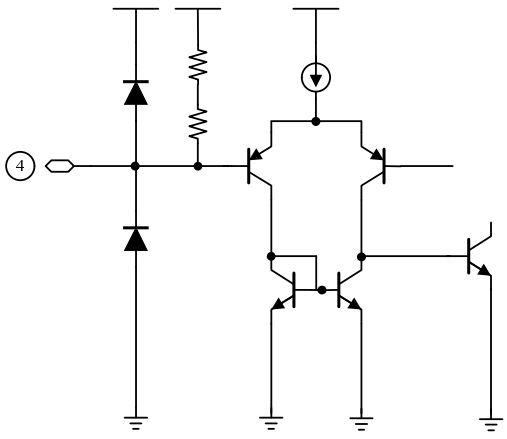
Pin no	Pin name	Internal circuit
4	ON / OFF	

ELECTRICAL CHARACTERISTICS CURVES

QUIESCENT CURRENT

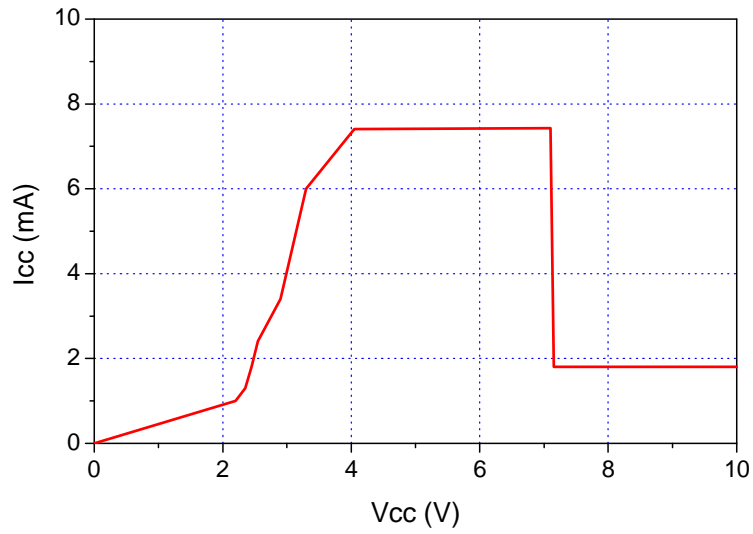

VREF TEMPERATURE STABILITY

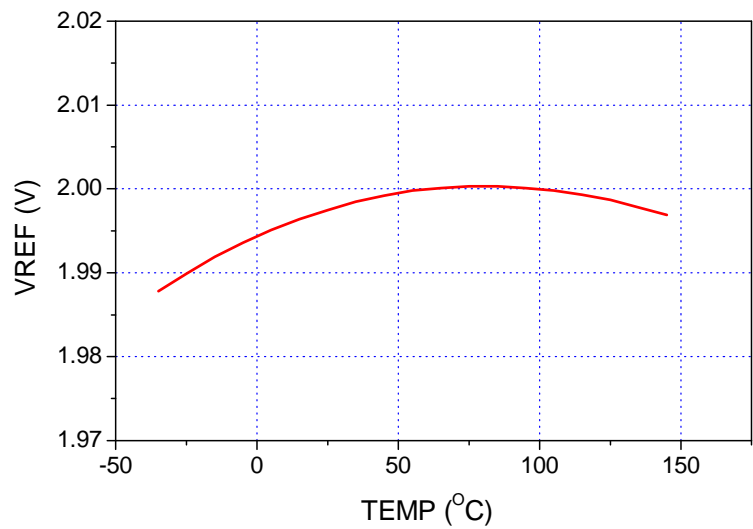

ELECTRICAL CHARACTERISTICS CURVES (Continued)

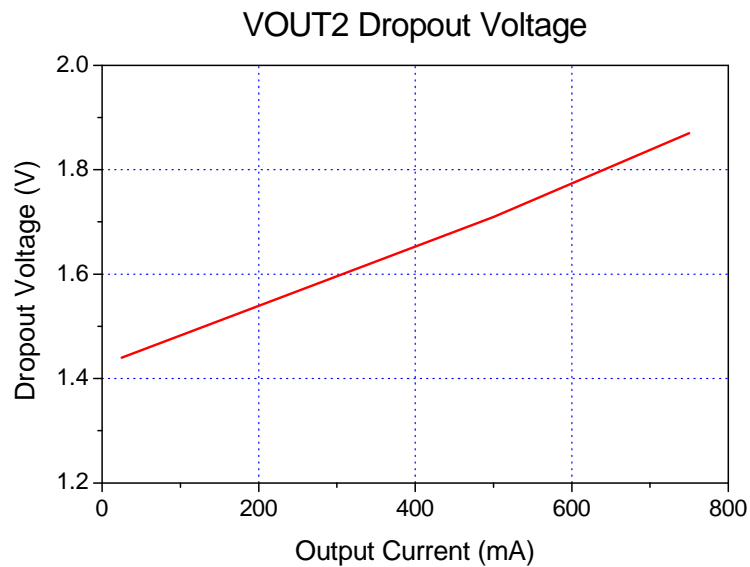
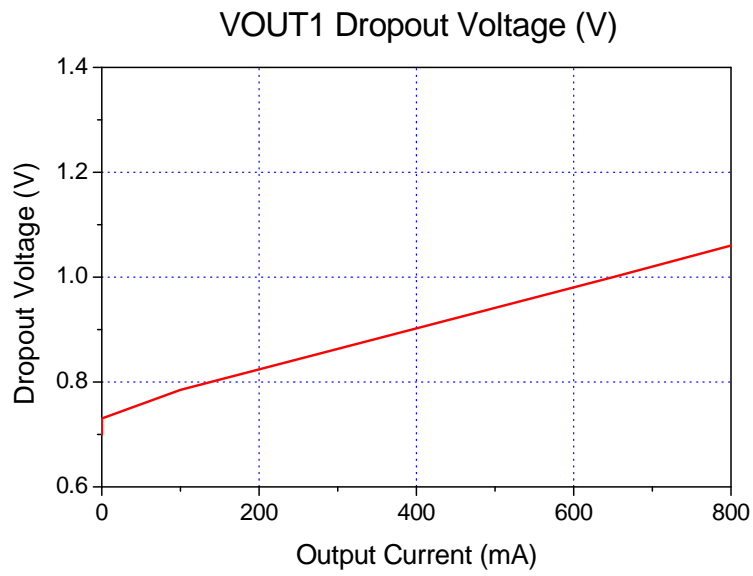

ELECTRICAL CHARACTERISTICS CURVES (Continued)

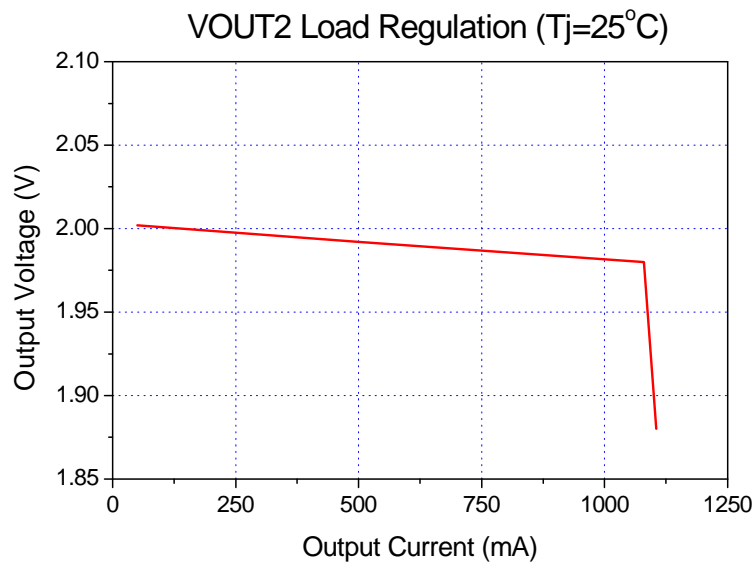
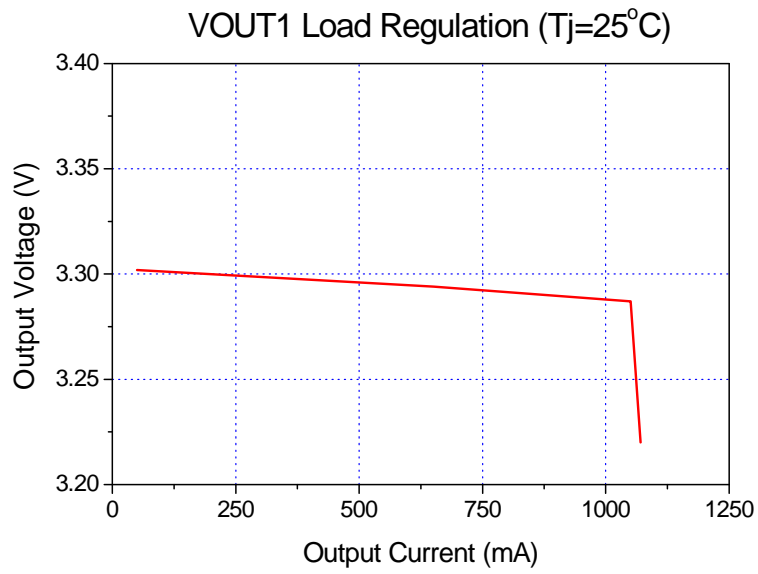

ELECTRICAL CHARACTERISTICS CURVES (Continued)

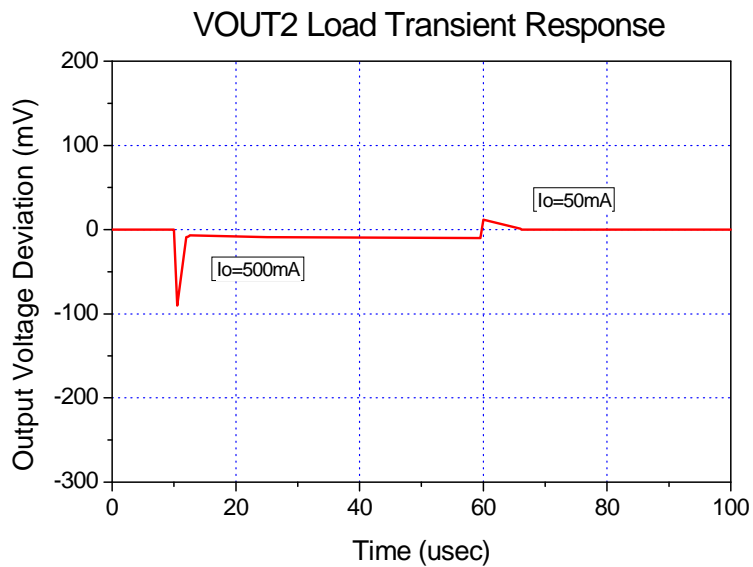
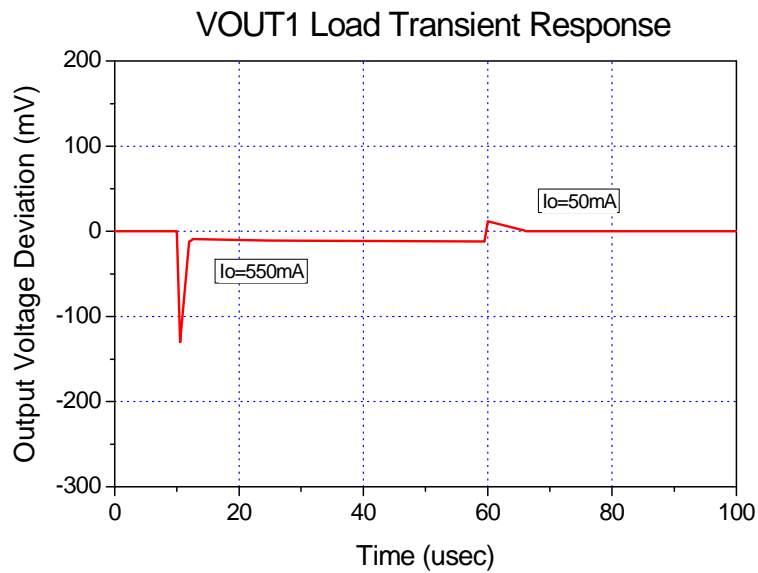

PACKAGE DIMENSION

14SOPH-8L

