

Green-Mode PWM Controller with Frequency Trembling and Integrated Protections

REV: 00

General Description

The LD7531A is built-in with several functions, protection and EMI-improved solution in a SOT-26/ DIP-8 package. It takes less components counts or circuit space, especially ideal for those total solutions of low cost.

The implemented functions include low startup current, green-mode power-saving operation, leading-edge blanking of the current sensing and internal slope compensation. And the LD7531A features more protections like OLP (Over Load Protection) and OVP (Over Voltage Protection) to prevent the circuit damage from the abnormal conditions.

Furthermore, the frequency trembling function is to reduce the noise level and thus helps the power circuit designers to easily deal with the EMI filter design by using minimum component cost and developing time.

Features

- High-Voltage CMOS Process with Excellent ESD protection
- Very Low Startup Current (<math><20\mu\text{A}</math>)
- Current Mode Control
- Non-audible-noise Green Mode Control
- UVLO (Under Voltage Lockout)
- LEB (Leading-Edge Blanking) on CS Pin
- Programmable Switching Frequency
- Internal Trembling ($\pm 4\text{KHz}$)
- Internal Slope Compensation
- OVP (Over Voltage Protection) on Vcc Pin
- OLP (Over Load Protection)
- 300mA Driving Capability

Applications

- Switching AC/DC Adaptor and Battery Charger
- Open Frame Switching Power Supply

Typical Application

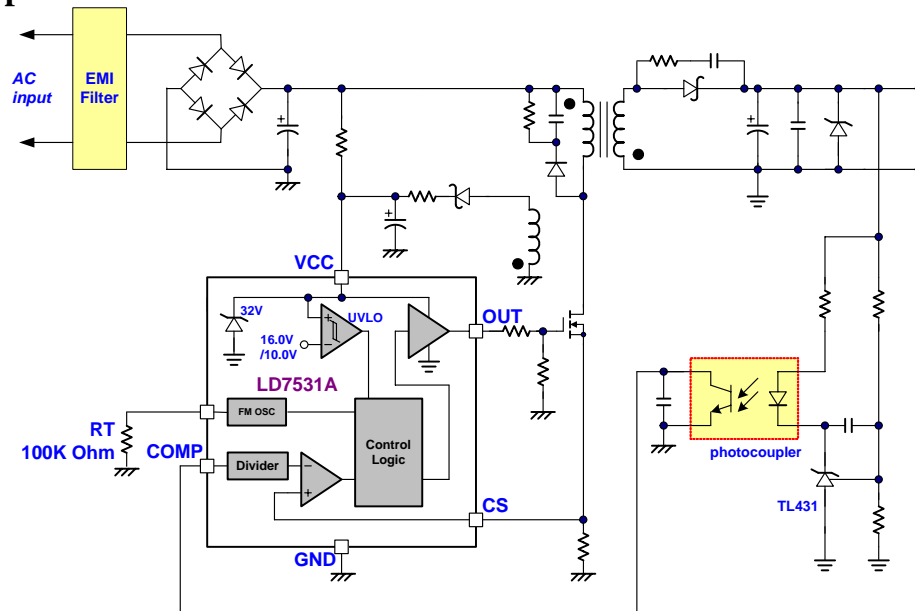

Pin Configuration

DIP-8 (TOP VIEW)

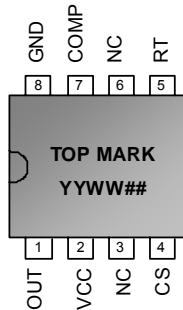

SOT-26 (TOP VIEW)

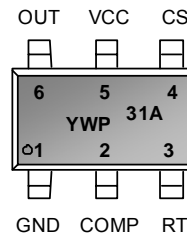

YY, Y: Year code (D: 2004, E: 2005.....)

WW, W: Week code

P : LD75..
(Product family code)

: Production code

Ordering Information

Part number	Package		TOP MARK	Shipping
LD7531A GL	SOT-26	Green Package	YWP/31A	3000 /tape & reel
LD7531A GN	DIP-8	Green Package	LD7531AGN	3600 /tube /Carton

Note: The LD7531A is ROHS compliant.

Pin Descriptions

PIN (DIP-8)	PIN (SOT-26)	NAME	FUNCTION
8	1	GND	Ground
7	2	COMP	Voltage feedback pin (same as the COMP pin in UC384X), By connecting a photo-coupler to close the control loop and achieve the regulation.
5	3	RT	This pin is to program the switching frequency. By connecting a resistor to ground to set the switching frequency.
4	4	CS	Current sense pin, connect to sense the MOSFET current
2	5	VCC	Supply voltage pin
1	6	OUT	Gate drive output to drive the external MOSFET

Block Diagram

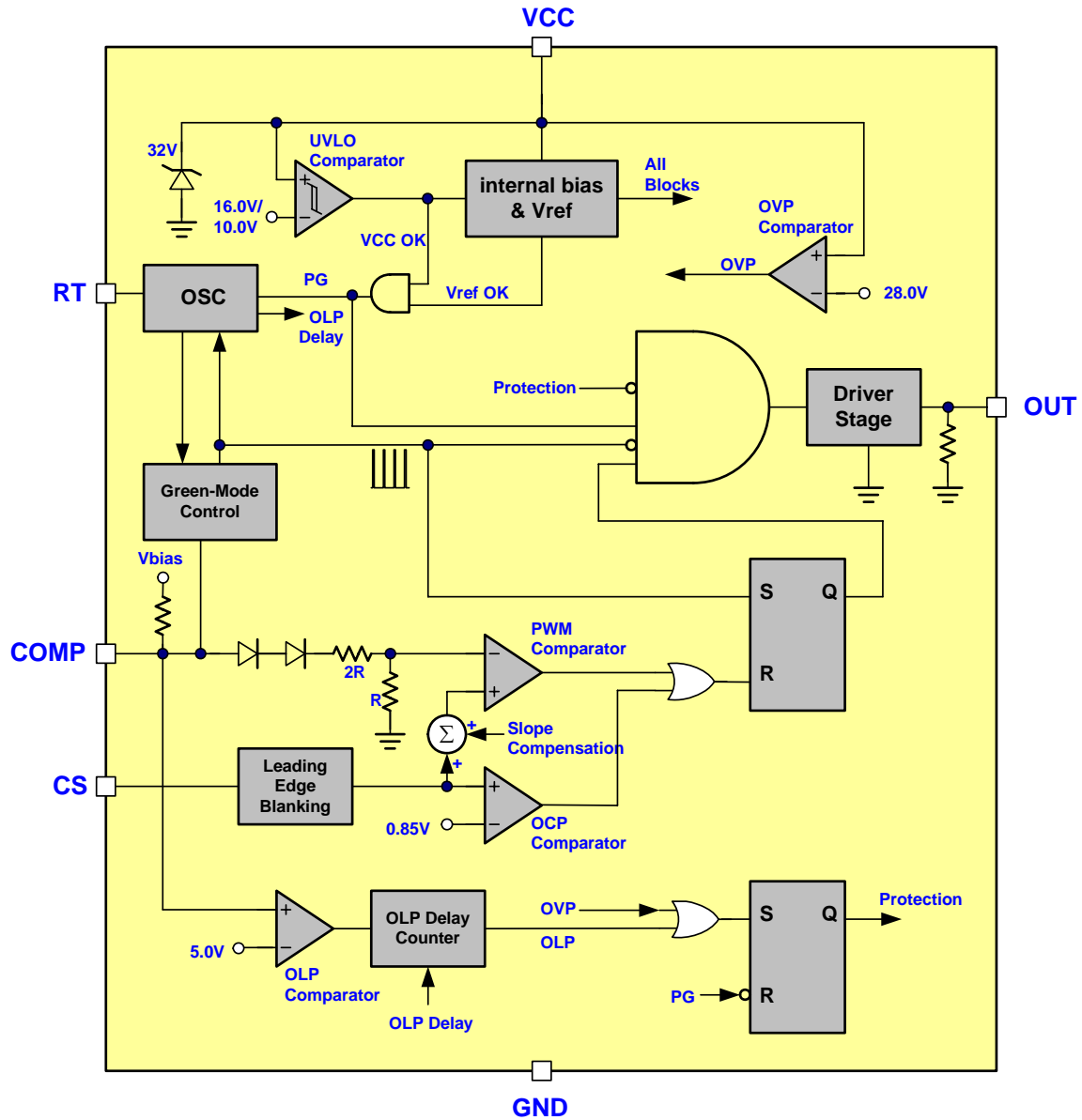

Absolute Maximum Ratings

Supply Voltage VCC.....	30V
COMP, RT, CS.....	-0.3 ~7V
OUT.....	-0.3 ~Vcc+0.3
Maximum Junction Temperature.....	150°C
Operating Ambient Temperature.....	-40°C to 85°C
Operating Junction Temperature.....	-40°C to 125°C
Storage Temperature Range.....	-65°C to 150°C
Package Thermal Resistance (SOT-26, θ_{JA}).....	250°C/W
Package Thermal Resistance (DIP-8, θ_{JA}).....	100°C/W
Power Dissipation (SOT-26, at Ambient Temperature = 85°C).....	250mW
Power Dissipation (DIP-8, at Ambient Temperature = 85°C).....	650mW
Lead temperature (Soldering, 10sec).....	260°C
ESD Voltage Protection, Human Body Model.....	2.5KV
ESD Voltage Protection, Machine Model.....	250 V
Gate Output Current.....	300mA

Caution:

Stresses beyond the ratings specified in "Absolute Maximum Ratings" may cause permanent damage to the device. This is a stress only rating and operation of the device at these or any other conditions above those indicated in the operational sections of this specification is not implied.

Recommended Operating Conditions

Item	Min.	Max.	Unit
Supply Voltage Vcc	11	25	V
RT Value	50	130	K Ω

Electrical Characteristics

($T_A = +25^{\circ}\text{C}$ unless otherwise stated, $V_{CC}=15.0\text{V}$)

PARAMETER	CONDITIONS	MIN	TYP	MAX	UNITS
Supply Voltage (Vcc Pin)					
Startup Current			12	20	μA
Operating Current (with 1nF load on OUT pin)	$V_{\text{COMP}}=0\text{V}$		2.65	3.5	mA
	$V_{\text{COMP}}=3\text{V}$		3.0		mA
	Protection tripped (OLP)		0.45		mA
	Protection tripped (OVP)		0.55		mA
UVLO (off)		9.0	10.0	11.0	V
UVLO (on)		15.0	16.0	17.0	V
OVP Level		26.8	28.0	29.2	V
Voltage Feedback (Comp Pin)					
Short Circuit Current	$V_{\text{COMP}}=0\text{V}$		1.3	2.2	mA
Open Loop Voltage	COMP pin open		5.9		V
Green Mode Threshold VCOMP			2.85		V
Current Sensing (CS Pin)					
Maximum Input Voltage, $V_{\text{CS off}}$		0.8	0.85	0.9	V
Leading Edge Blanking Time	$V_{\text{COMP}}>1.9\text{V}$		240		ns
	$V_{\text{COMP}}<1.8\text{V}$		1400		ns
Input impedance		1			$\text{M}\Omega$
Delay to Output			100		ns
Oscillator for Switching Frequency					
Frequency	$R_T=100\text{K}\Omega$	60	65	70	kHz
Green Mode Frequency	$F_s=65\text{kHz}$		21		kHz
Trembling Frequency			± 4.0		kHz
Temp. Stability	($-40^{\circ}\text{C} \sim 105^{\circ}\text{C}$)			5	%
Voltage Stability	($V_{CC}=11\text{V}-25\text{V}$)			1	%
Gate Drive Output (OUT Pin)					
Output Low Level	$V_{CC}=15\text{V}$, $I_o=20\text{mA}$			1	V
Output High Level	$V_{CC}=15\text{V}$, $I_o=20\text{mA}$	8			V
Rising Time	Load Capacitance=1000pF		170	350	ns
Falling Time	Load Capacitance=1000pF		50	100	ns
OLP (Over Load Protection)					
OLP Trip Level	V_{COMP} (OLP)		5.0		V
OLP Delay Time at start-up	$F_s=65\text{kHz}$		70		ms
OLP Delay Time	$F_s=65\text{kHz}$		40		ms

* R_T value is in proportion to OLP delay time.

Typical Performance Characteristics

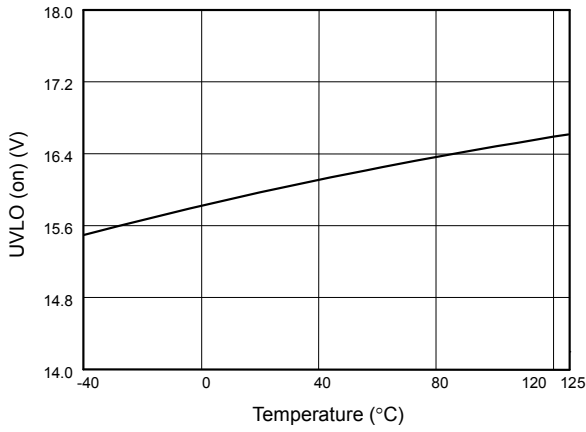

Fig. 1 UVLO (on) vs. Temperature

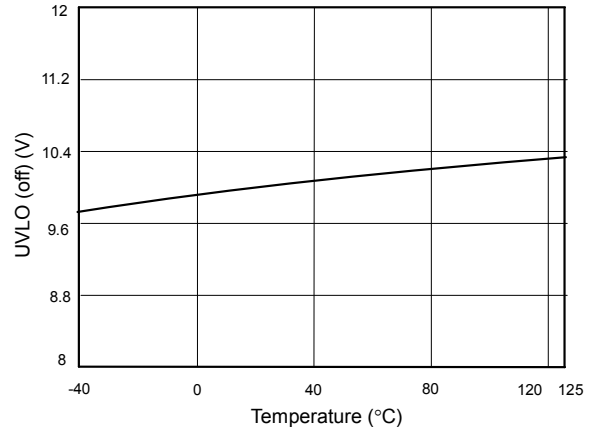

Fig. 2 UVLO (off) vs. Temperature

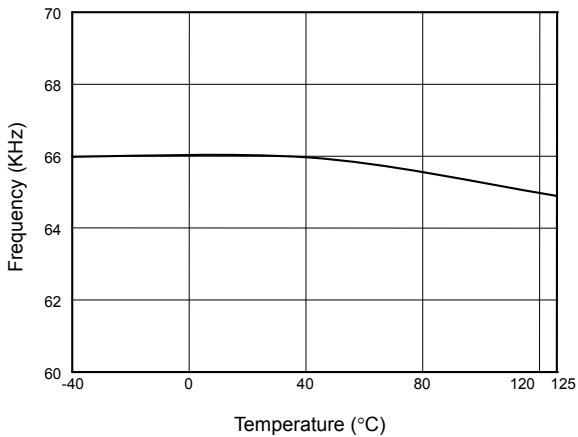

Fig. 3 Frequency vs. Temperature

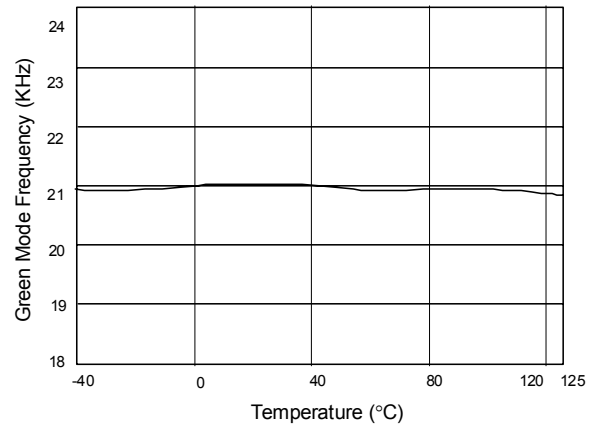

Fig. 4 Green Mode Frequency vs. Temperature

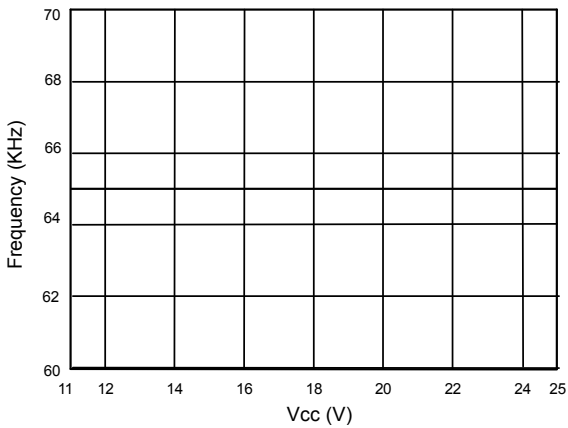

Fig. 5 Frequency vs. Vcc

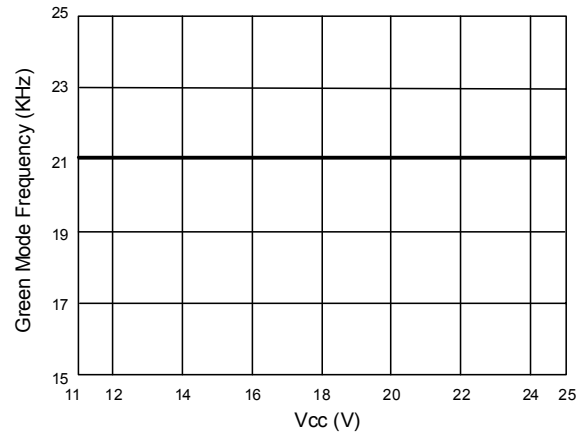

Fig. 6 Green Mode Frequency vs. Vcc

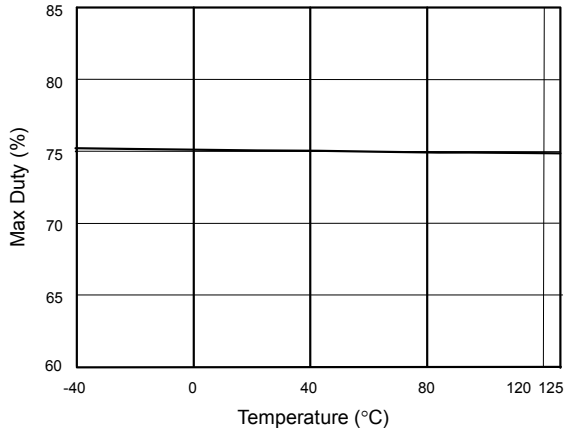

Fig. 7 Max Duty vs. Temperature

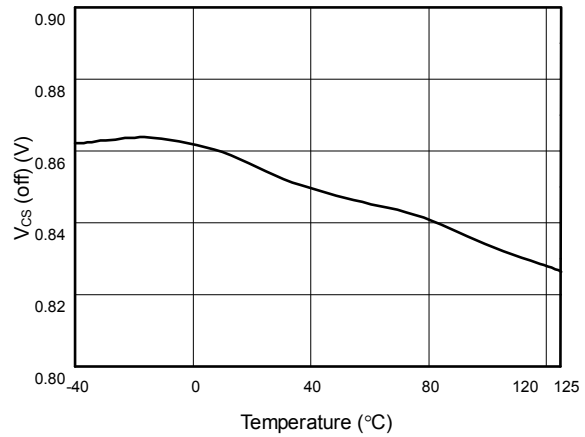

Fig. 8 V_{CS} (off) vs. Temperature

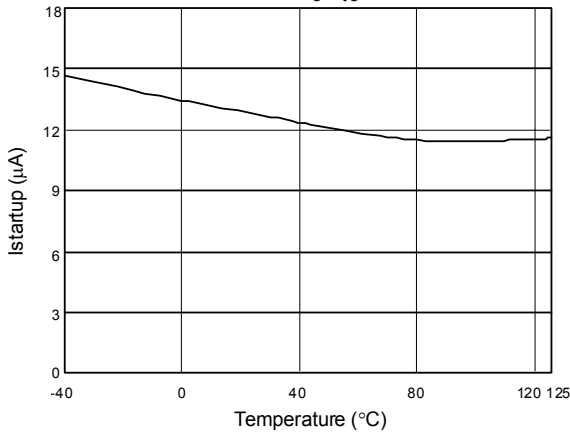

Fig. 9 Startup Current (I_{startup}) vs. Temperature

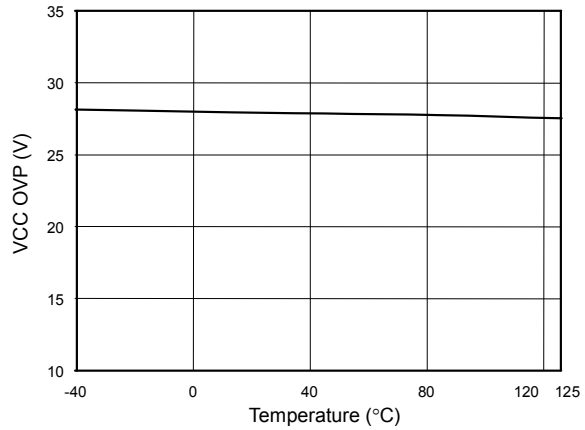

Fig. 10 VCC OVP vs. Temperature

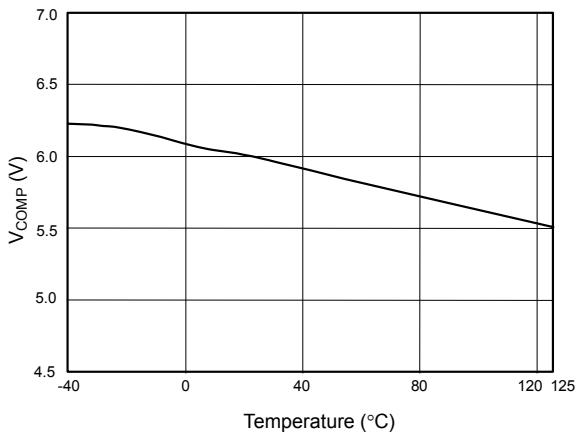

Fig. 11 V_{COMP} open loop voltage vs. Temperature

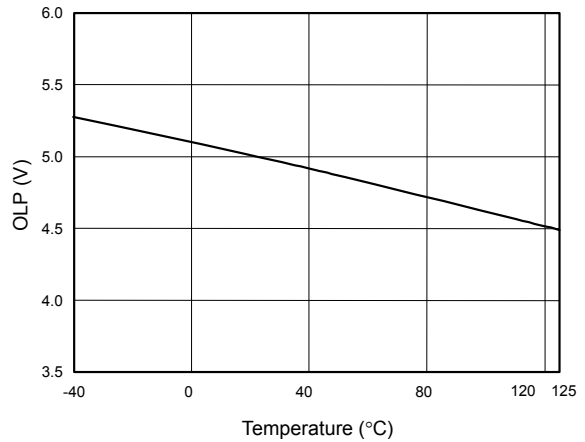

Fig. 12 OLP-Trip Level vs. Temperature

Application Information

Operation Overview

The LD7531A meets the green-power requirement and is intended for the use in those modern switching power suppliers and adaptors which demand higher power efficiency and power-saving. It integrated more functions to reduce the external components counts and the size. Its major features are described as below.

Under Voltage Lockout (UVLO)

An UVLO comparator is implemented in it to detect the voltage on the VCC pin. It would assure the supply voltage enough to turn on the LD7531A PWM controller and further to drive the power MOSFET. As shown in Fig. 13, a hysteresis is built in to prevent the shutdown from the voltage dip during startup. The turn-on and turn-off threshold level are set at 16.0V and 10.0V, respectively.

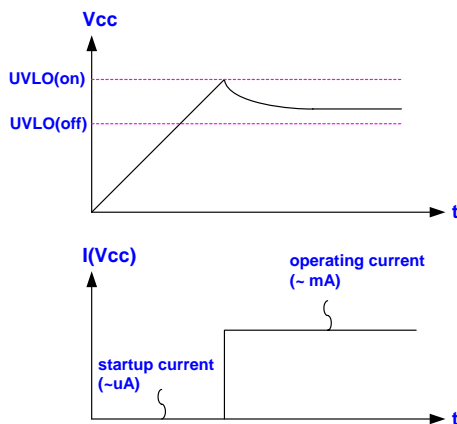

Fig. 13

Startup Current and Startup Circuit

The typical startup circuit to generate the LD7531A Vcc is shown in Fig. 14. During the startup transient, the Vcc is lower than the UVLO threshold thus there is no gate pulse produced from LD7531A to drive power MOSFET. Therefore, the current through R1 will provide the startup current and to charge the capacitor C1. Whenever the Vcc voltage is high enough to turn on the LD7531A and

further to deliver the gate drive signal, the supply current is provided from the auxiliary winding of the transformer. Lower startup current requirement on the PWM controller will help to increase the value of R1 and then reduce the power consumption on R1. By using CMOS process and the special circuit design, the maximum startup current of LD7531A is only 20 μ A.

If a higher resistance value of the R1 is chosen, it usually takes more time to start up. To carefully select the value of R1 and C1 will optimize the power consumption and startup time.

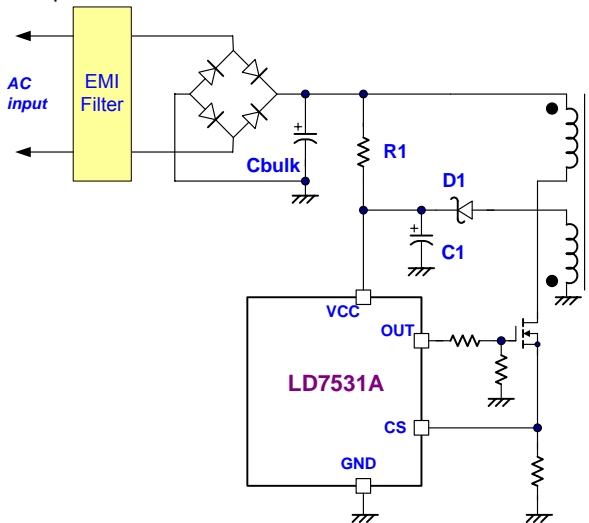

Fig. 14

Current Sensing and Leading-edge Blanking

The typical current mode of PWM controller feedbacks both current signal and voltage signal to close the control loop and achieve regulation. As shown in Fig. 15, the LD7531A detects the primary MOSFET current from the CS pin, which is not only for the peak current mode control but also for the pulse-by-pulse current limit. The maximum voltage threshold of the current sensing pin is set at 0.85V. From above, the MOSFET peak current can be obtained from below.

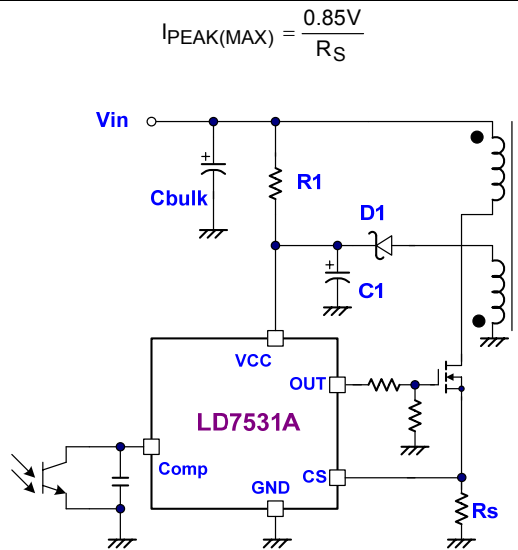

Fig. 15

A 240nS leading-edge blanking (LEB) time is included in the input of CS pin to prevent the false-trigger from the current spike. In the low power application, if the total pulse width of the turn-on spikes is below 240nS and the negative spike on the CS pin doesn't exceed -0.3V, the R-C filter can be eliminated (as shown in the figure16).

However, the total pulse width of the turn-on spike is decided by the output power, circuit design and PCB layout. It is strongly recommended to employ a smaller R-C filter (as shown in figure 17) for higher power application to avoid the CS pin being damaged by the negative turn-on spike.

Output Stage and Maximum Duty-Cycle

An output stage of a CMOS buffer, with typical 500mA driving capability, is incorporated to drive a power MOSFET directly. And the maximum duty-cycle of LD7531A is limited to 75% to avoid the transformer saturation.

Voltage Feedback Loop

The voltage feedback signal is provided from the TL431 at the secondary side through the photo-coupler to the COMP pin of the LD7531A. Similar to UC3842, the

LD7531A would carry 2 diodes voltage offset at the stage to feed the voltage divider at the ratio of 1/3, that is,

$$V_{-(PWM_{COMPARATOR})} = \frac{1}{3} \times (V_{COMP} - 2V_F)$$

A pull-high resistor is embedded internally and is removable externally.

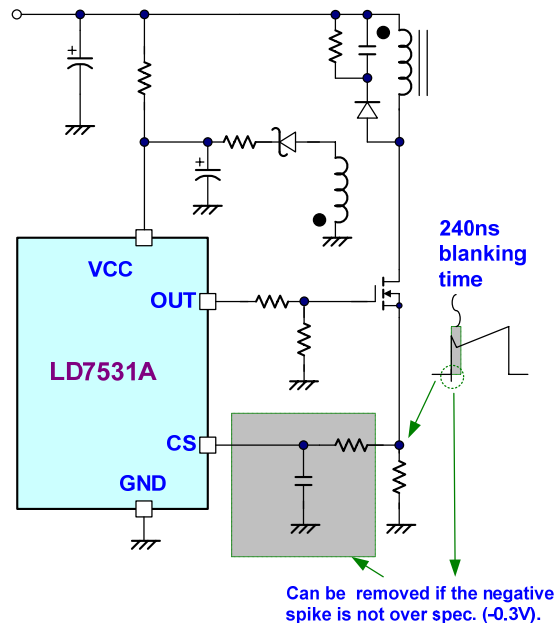

Fig. 16

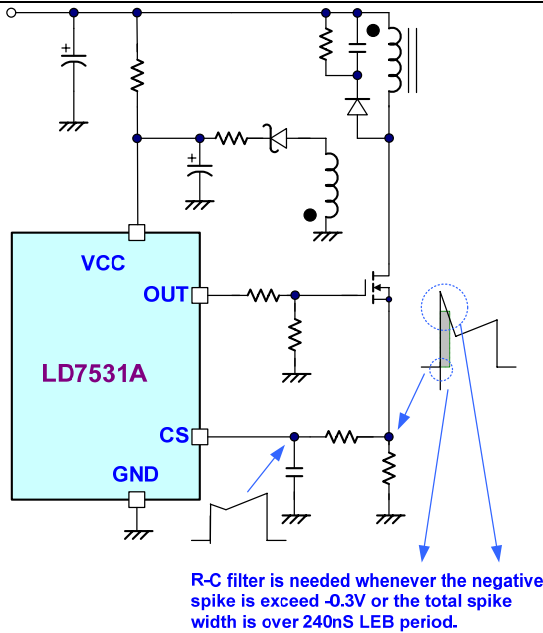

Fig. 17

Oscillator and Switching Frequency

The switching frequency of LD7531A is programmed as an external resistor on RT to provide the optimized operations by considering the EMI performance, thermal treatment, component sizes and transformer design.

Internal Slope Compensation

In the conventional application, the problem of the stability is a critical issue for current mode controlling, when it operates over 50% duty-cycle. As UC384X, It takes slope compensation from injecting the ramp signal of the RT/CT pin through a coupling capacitor. It therefore requires no extra design for the LD7531A since it has integrated it already.

On/Off Control

The LD7531A can be turned off by pulling COMP pin below 1.6V. The gate output pin of the LD7531A will be disabled immediately under such condition. The off-mode can be released when the pull-low signal is removed.

Dual-Oscillator Green-Mode Operation

There are many different topologies has been implemented in different chips for the green-mode or power saving requirements such as “burst-mode control”, “skipping-cycle mode”, “variable off-time control” ...etc. The basic operation theory of all these approaches intended to reduce the switching cycles under light-load or no-load condition either by skipping some switching pulses or reduce the switching frequency. By using this dual-oscillator control, the green-mode frequency can be well controlled and further to avoid the generation of audible noise.

OVP (Over Voltage Protection) on Vcc

The VGS ratings of the nowadays power MOSFETs are often limited below 30V. To prevent VGS from the fault condition, the LD7531A is implemented with OVP function on Vcc. As soon as the Vcc voltage is over OVP threshold voltage, the output gate drive circuit will be shutdown simultaneously thus to stop the switching of the power MOSFET until the next UVLO(on). The Vcc OVP function of the LD7531A is an auto-recovery protection. The figure 18 shows its operation. Upon removal of the OVP condition will resume the Vcc leve and the output operation

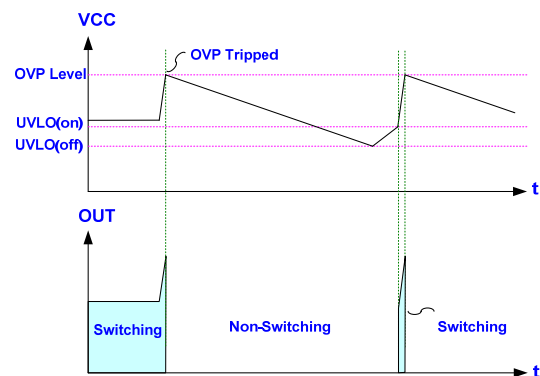

Fig. 18

Over Load Protection (OLP)

To protect the circuit from being damaged under over load condition or short condition, a smart OLP function is implemented in the LD7531A. The Figure 19 shows the waveforms of the OLP operation. In this case, the feedback system will force the voltage loop proceed toward the saturation and then pull up the voltage on COMP pin (V_{COMP}). Whenever the V_{COMP} trips up to the OLP threshold 5V and stays longer than the OLP delay time, the protection will activate and then turn off the gate output to stop the switching of power circuit. The OLP delay time is to prevent the false trigger from the power-on and turn-off transient. Typically the OLP delay time will be around 40mS. In order to provide the more start-up capability, the OLP delay time at start-up will be around 70ms.

By such protection mechanism, the average input power can be reduced to very low level so that the component temperature and stress can be controlled within the safe operating area.

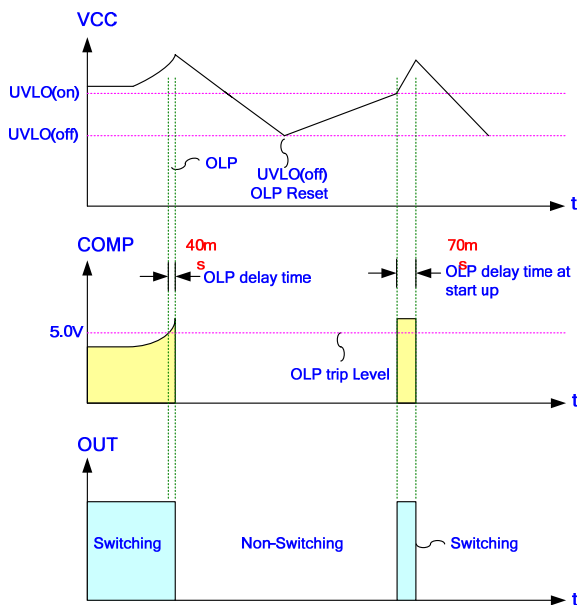

Fig. 19

Fault Protection

There are several critical protections were integrated in the

LD7531A to prevent the power supply or adapter had being damaged. Those damages usually come from open condition on the pins of LD7531A.

Under the conditions listed below, the gate output will turn off immediately to protect the power circuit ---

1. RT pin floating
2. CS pin floating

Reference Application Circuit --- 50W (12V/4.2A) Adapter

Schematic

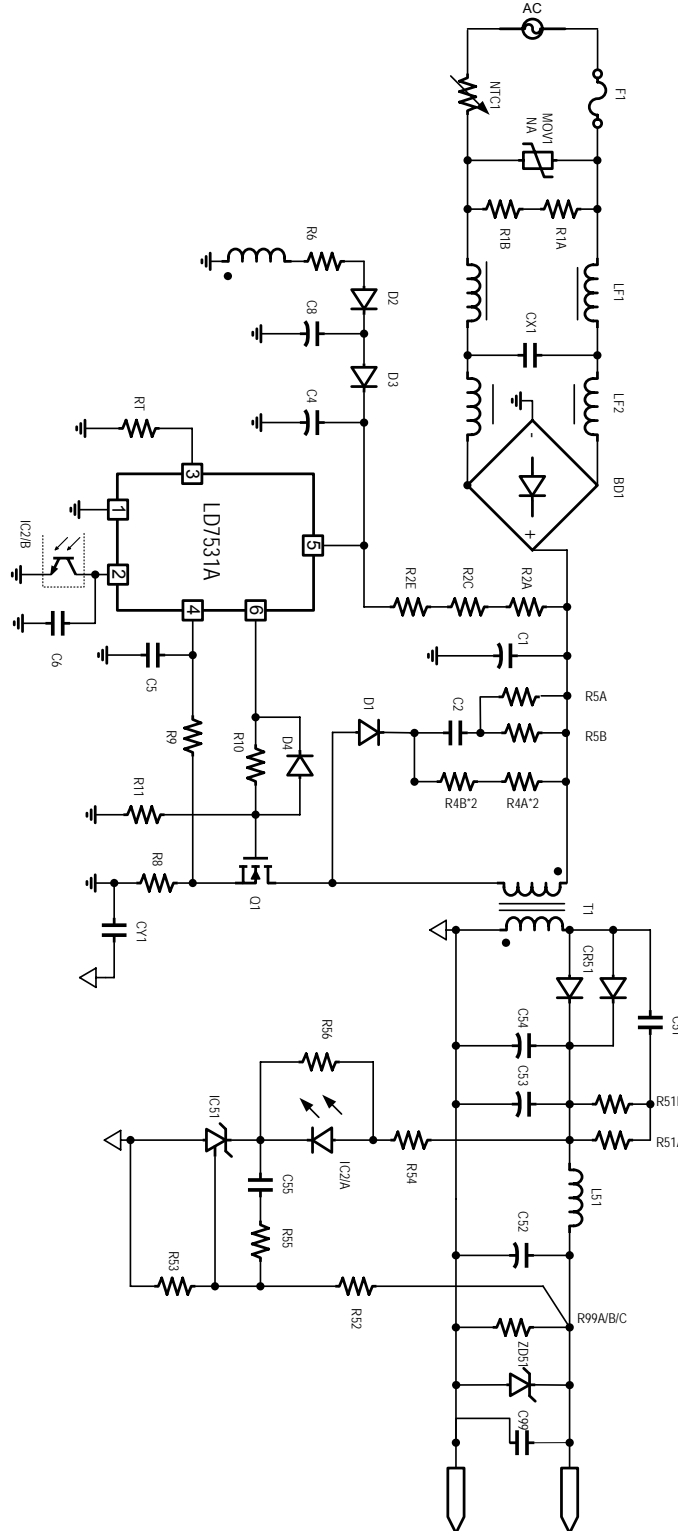

Reference Application Circuit --- 50W (12V/4.2A) Adapter

BOM

P/N	Component Value	Note
R1A	1MΩ, 1206, 1%	
R1B	1MΩ, 1206, 1%	
R2A	1MΩ, 1206, 1%	
R2C	1MΩ, 1206, 1%	
R2E	1MΩ, 1206, 1%	
R4A/1	100KΩ, 1206, 1%	
R4A/2	100KΩ, 1206, 1%	
R4B/1	100KΩ, 1206, 1%	
R4B/2	100KΩ, 1206, 1%	
R5A	22Ω, 1206, 1%	
R5B	22Ω, 1206, 1%	
R6	0Ω, 1206, 5%	
R8	0.43Ω, 2WS	
R9	200Ω, 0805, 1%	
R10	15Ω, 1206, 1%	
R11	20KΩ, 1206, 1%	
RT	100KΩ, 0805, 1%	
R51A	75Ω, 1206, 1%	
R51B	75Ω, 1206, 1%	
R52	9.53KΩ, 0805, 1%	
R53	2.49KΩ, 0805, 1%	
R54	510Ω, 0805, 1%	
R55	3KΩ, 0805, 1%	
R56	NA	
R99A	4.7KΩ, 1206, 1%	
R99B	NA	
R99C	NA	
NTC1	3A, 5Ω	
LF1	Leadtrend's Design	
LF2	Leadtrend's Design	
T1	Leadtrend's Design	
L51	Leadtrend's Design	

P/N	Component Value	Note
C1	100μF, 400V	TY
C2	1000pF, 1000V, 1206	
C4	3.3μF, 50V	LZG
C5	220pF, 50V, 0805	
C6	3.3nF, 50V, 0805	
C8	10μF, 50V	LZG
C51	1000pF, 1000V, 1206	
C52	220μF, 25V	LZG
C53	1500μF, 16V	LZG
C54	1500μF, 16V	LZG
C55	10nF, 50V, 0805	
C99	NA	
CX1	0.33μF, X-cap	
CY1	2200pF, Y-cap, class1	
D1	1N4007	
D2	1N4007	
D3	1N4148,	
D4	1N4148	
Q1	8A, 600V	
BD1	2A, 600V	
CR51	10A, 100V	
ZD51	NA	
IC1	LD7531A	Leadtrend
IC2	EL817B	
IC51	KA431, 1%	
F1	250V, T2A	Walter
MOV1	NA	

Package Information

SOT-26

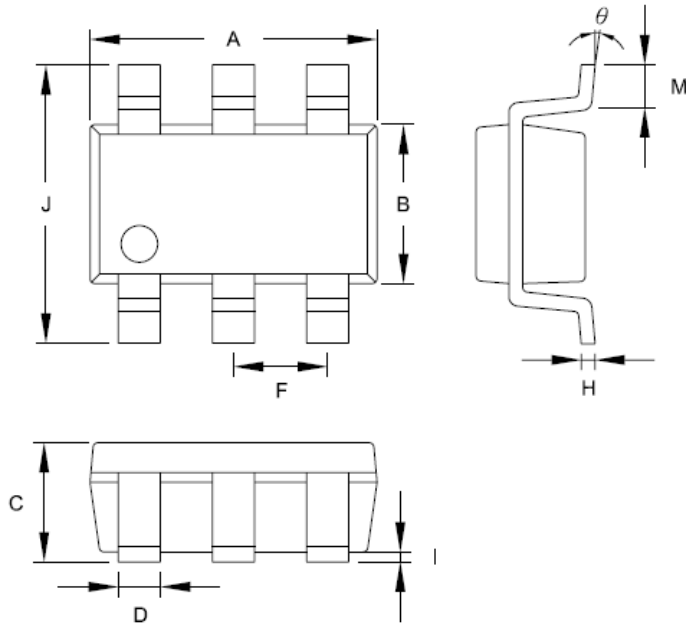

Symbol	Dimension in Millimeters		Dimensions in Inches	
	Min	Max	Min	Max
A	2.692	3.099	0.106	0.122
B	1.397	1.803	0.055	0.071
C	---	1.450	---	0.057
D	0.300	0.500	0.012	0.022
F	0.95 TYP		0.037 TYP	
H	0.080	0.254	0.003	0.010
I	0.050	0.150	0.002	0.006
J	2.600	3.000	0.102	0.118
M	0.300	0.600	0.012	0.024
θ	0°	10°	0°	10°

Package Information

DIP-8

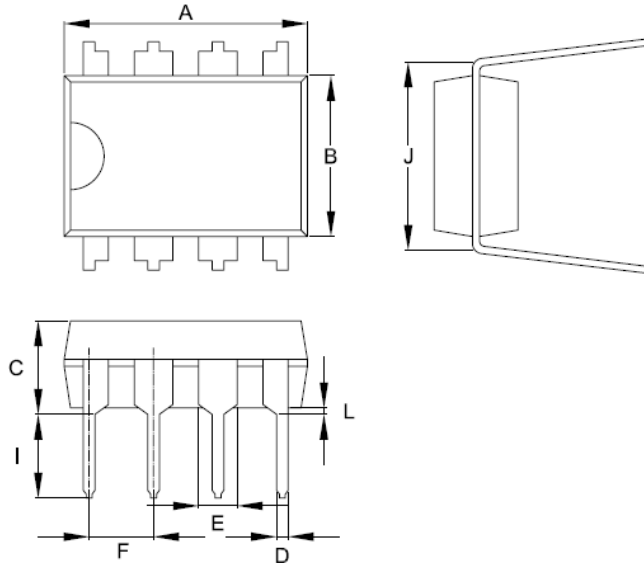

Symbol	Dimension in Millimeters		Dimensions in Inches	
	Min	Max	Min	Max
A	9.017	10.160	0.355	0.400
B	6.096	7.112	0.240	0.280
C	-----	5.334	-----	0.210
D	0.356	0.584	0.014	0.023
E	1.143	1.778	0.045	0.070
F	2.337	2.743	0.092	0.108
I	2.921	3.556	0.115	0.140
J	7.366	8.255	0.290	0.325
L	0.381	-----	0.015	-----

Important Notice

Leadtrend Technology Corp. reserves the right to make changes or corrections to its products at any time without notice. Customers should verify the datasheets are current and complete before placing order.

Revision History

Rev.	Date	Change Notice
00	7/6/2009	Original Specification