

Features :

- * 65,536 words by 16 bits organization.
- * Fast access time and cycle time.
- * Dual \overline{WE} Input.
- * Low power dissipation.
- * Read-Modify-Write, \overline{RAS} -Only Refresh, \overline{CAS} -Before- \overline{RAS} Refresh, Hidden Refresh and Test Mode Capability.
- * 256 refresh cycles per 4ms.
- * Available in 40-pin 400 mil SOJ, and 40/44 pin TSOP(II).
- * Single 5.0V \pm 10% Power Supply, Except 5V+5%,-10% for 30ns TSOPII Package.
- * All inputs and Outputs are TTL compatible.
- * Extended Data-Out(EDO) Page Mode operation.

Description :

The GLT41216 is a 65,536 x 16 bit high-performance CMOS dynamic random access memory. The GLT41216 offers Fast Page mode with Extended Data Output, and has both BYTE WRITE and WORD WRITE access cycles via two \overline{WE} pins. The GLT41216 accepts 256-cycle refresh in 4ms interval.

All inputs are TTL compatible. EDO Page Mode operation allows random access up to 256 x 16 bits, within a page, with cycle times as short as 12ns.

The GLT41216 is best suited for graphics, and DSP applications requiring high performance memories.

HIGH PERFORMANCE	30	35	40	45
Max. \overline{RAS} Access Time, (t_{RAC})	30 ns	35 ns	40 ns	45 ns
Max. Column Address Access Time, (t_{AA})	15 ns	18 ns	20 ns	22 ns
Min. Extended Data Out Page Mode Cycle Time, (t_{PC})	12 ns	13 ns	15 ns	18 ns
Min. Read/Write Cycle Time, (t_{RC})	65 ns	70 ns	75 ns	80 ns
Max. \overline{CAS} Access Time (t_{CAC})	10 ns	11 ns	12 ns	12 ns

Pin Configuration :

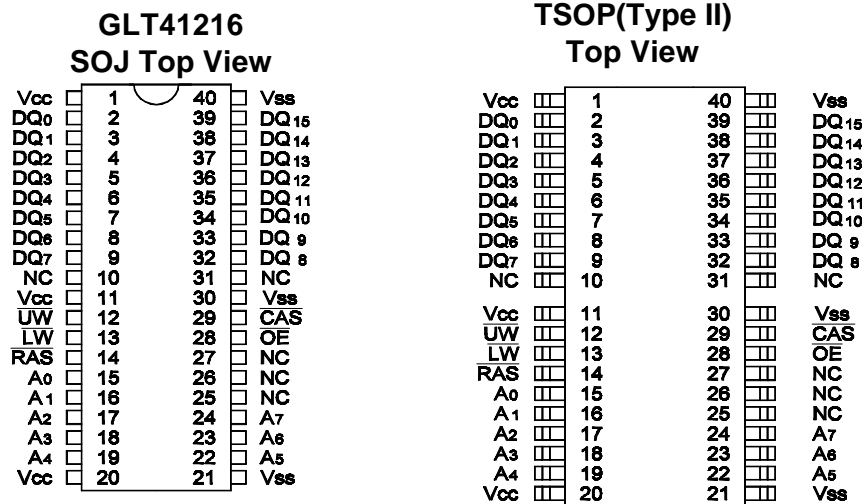

Pin Descriptions:

Name	Function
A ₀ - A ₇	Address Inputs
$\overline{\text{RAS}}$	Row Address Strobe
$\overline{\text{CAS}}$	Column Address Strobe
$\overline{\text{UW}}$	Read/Upper Byte Write Enable
$\overline{\text{LW}}$	Read/Lower Byte Write Enable
$\overline{\text{OE}}$	Output Enable
DQ ₀ - DQ ₁₅	Data Inputs / Outputs
V _{CC}	+5V Power Supply
V _{SS}	Ground
NC	No Connection

Extended Data Output (EDO) Page Mode

The EDO page mode is a kind of page mode with enhanced features. The two major features of the EDO page mode are as follows.

1. Data output time is extended.

In the EDO page mode, the output data is held to the next $\overline{\text{CAS}}$ cycle's falling edge, instead of the rising edge. For this reason, valid data output time in the EDO page mode is extended compared with the fast page mode (=data extend function). In the fast page mode, the data output time becomes shorter as the $\overline{\text{CAS}}$ cycle time becomes shorter. Therefore, in the EDO page mode, the timing margin in read cycle is larger than of the fast page mode even if the $\overline{\text{CAS}}$ cycle time becomes shorter.

2. The $\overline{\text{CAS}}$ cycle time in the EDO page mode is shorter than that in the fast page mode.

In the EDO page mode, due to the data extend function, the $\overline{\text{CAS}}$ cycle time can be shorter than in the fast page mode if the timing margin is the same.

Taking a device whose t_{RAC} is 60ns as an example, the $\overline{\text{CAS}}$ cycle time in the EDO page mode is 25ns while that in the fast page mode is 40ns.

In the EDO page mode, read (data out) and write (data in) cycles can be executed repeatedly during one $\overline{\text{RAS}}$ cycle. The EDO page mode allows both read and write operations during one cycle, but the performance is equivalent to that of the fast page mode in that case.

Truth Table: GLT41216

Function		RAS	CAS	UW	LW	OE	ADDRESS	DQs	Notes
Standby		H	H→X	X	X	X		High-Z	
Read: Word		L	L	H	H	L	ROW/COL	Data Out	
Write: Word(Early Write)		L	L	L	L	X	ROW/COL	Data-In	
Write: Lower Byte (Early)		L	L	H	L	X	ROW/COL	Lower Byte,Data-In Upper Byte,High-Z	
Write: Upper Byte (Early)		L	L	L	H	X	ROW/COL	Lower Byte,High-Z Upper Byte,Data-In	
Read Write		L	L	H→L	H→L	L→H	ROW/COL	Data-Out,Data-In	1,2
EDO-Page- Mode Read	1st Cycle	L	H→L	H	H	L	ROW/COL	Data-Out	1
	2nd Cycle	L	H→L	H	H	L	COL	Data-Out	1
EDO-Page- Mode Write	1st Cycle	L	H→L	L	L	X	ROW/COL	Data-In	2
	2nd Cycle	L	H→L	L	L	X	COL	Data-In	2
EDO-Page- Mode Read- Write	1st Cycle	L	H→L	H→L	H→L	L→H	ROW/COL	Data-Out,Data-In	1,2
	2st Cycle	L	H→L	H→L	H→L	L→H	COL	Data-Out,Data-In	1,2
Hidden Refresh	Read	L→H→L	L	H	H	L	ROW/COL	Data-Out	1
	Write	L→H→L	L	L	L	X	ROW/COL	Data-In	2,3
RAS -Only Refresh		L	H	X	X	X	ROW	High-Z	
CBR Refresh		H→L	L	X	X	X		High-Z	

Notes:

1. These READ cycles are always WORD READ cycles.
2. These WRITE cycles may also be BYTE READ cycles (either \overline{UW} or \overline{LW} active).
3. EARLY WRITE only.

DC and Operating Characteristics (1-2)
 $T_A = 0^\circ\text{C to } 70^\circ\text{C}$, $V_{CC}=5V\pm 10\%$, $V_{SS}=0V$, unless otherwise specified.

Sym.	Parameter	Test Conditions	Access Time	Min.	Typ	Max.	Unit	Notes
I_{LI}	Input Leakage Current (any input pin)	$0V \leq V_{IN} \leq 5.5V$ (All other pins not under test=0V)		-10		+10	μA	
I_{LO}	Output Leakage Current (for High-Z State)	$0V \leq V_{out} \leq 5.5V$ Output is disabled (Hiz)		-10		+10	μA	
I_{CC1}	Operating Current, Random READ/WRITE	$t_{RC} = t_{RC}(\text{min.})$	$t_{RAC} = 30\text{ns}$ $t_{RAC} = 35\text{ns}$ $t_{RAC} = 40\text{ns}$ $t_{RAC} = 45\text{ns}$			180 170 160 150	mA	1,2
I_{CC2}	Standby Current,(TTL)	$\overline{\text{RAS}}, \overline{\text{CAS}}$, at V_{IH} other inputs $\geq V_{SS}$				2	mA	
I_{CC3}	Refresh Current, RAS -Only	$\overline{\text{RAS}}$ cycling, $\overline{\text{CAS}}$, at V_{IH} $t_{RC} = t_{RC}(\text{min.})$	$t_{RAC} = 30\text{ns}$ $t_{RAC} = 35\text{ns}$ $t_{RAC} = 40\text{ns}$ $t_{RAC} = 45\text{ns}$			180 170 160 150	mA	2
I_{CC4}	Operating Current, EDO Page Mode	$\overline{\text{RAS}}$ at V_{IL} , $\overline{\text{CAS}}$ address cycling: $t_{PC} = t_{PC}(\text{min.})$	$t_{RAC} = 30\text{ns}$ $t_{RAC} = 35\text{ns}$ $t_{RAC} = 40\text{ns}$ $t_{RAC} = 45\text{ns}$			180 170 160 150	mA	1,2
I_{CC5}	Refresh Current, CAS Before RAS	$\overline{\text{RAS}}, \overline{\text{CAS}}$, address cycling: $t_{RC} = t_{RC}(\text{min.})$	$t_{RAC} = 30\text{ns}$ $t_{RAC} = 35\text{ns}$ $t_{RAC} = 40\text{ns}$ $t_{RAC} = 45\text{ns}$			180 170 160 150	mA	1
I_{CC6}	Standby Current, (CMOS)	$\overline{\text{RAS}} \geq V_{CC}-0.2V$, $\overline{\text{CAS}} \geq V_{CC}-0.2V$, All other inputs V_{SS}				1	mA	
V_{IL}	Input Low Voltage			-1		+0.8	V	3
V_{IH}	Input High Voltage			2.4		$V_{CC}+1$	V	3
V_{OL}	Output Low Voltage	$I_{OL} = 4.2\text{mA}$				0.4	V	
V_{OH}	Output High Voltage	$I_{OH} = -5\text{mA}$		2.4			V	

Notes:

- I_{CC} is dependent on output loading when the device output is selected. Specified $I_{CC}(\text{max.})$ is measured with the output open.
- I_{CC} is dependent upon the number of address transitions specified $I_{CC}(\text{max.})$ is measured with a maximum of one transition per address cycle in random Read/Write and EDO Fast Page Mode.
- Specified $V_{IL}(\text{min.})$ is steady state operation. During transitions $V_{IL}(\text{min.})$ may undershoot to -1.0V for a period not to exceed 20ns. All AC parameters are measured with $V_{IL}(\text{min.}) \geq V_{SS}$ and $V_{IH}(\text{max.}) \leq V_{CC}$.

G-Link Technology Corporation, Taiwan

 Web : www.glink.com.tw Email : sales@glink.com.tw

TEL : 886-2-27968078

AC Characteristics

$T_A = 0^\circ\text{C}$ to 70°C , $V_{CC} = 5\text{ V} \pm 10\%$, $V_{IH}/V_{IL} = 2.4/0.8\text{ V}$, $V_{OH}/V_{OL} = 2.0/0.8\text{ V}$

An initial pause of 100 μs and 8 $\overline{\text{CAS}}$ -before-RAS or RAS-only refresh cycles are required after power-up.

Parameter	Symbol	30		35		40		45		Unit	Notes
		Min.	Max.	Min.	Max.	Min.	Max.	Min.	Max.		
Read or Write Cycle Time	t_{RC}	65		70		75		80		ns	
Read Modify Write Cycle Time	t_{RWC}	85		87		93		103		ns	
RAS Precharge Time	t_{RP}	25		25		25		30		ns	
RAS Pulse Width	t_{RAS}	30	100k	35	100k	40	100k	45	100k	ns	
Access Time from $\overline{\text{RAS}}$	t_{RAC}		30		35		40		45	ns	1,2,3
Access Time from $\overline{\text{CAS}}$	t_{CAC}		10		11		12		12	ns	1,5,10
Access Time from Column Address	t_{AA}		15		18		20		22	ns	1,5,6
$\overline{\text{CAS}}$ to Output Low-Z	t_{CLZ}	0		0		0		0		ns	
$\overline{\text{CAS}}$ to Output High-Z	t_{CEZ}	3		3	8	3	8	3	8	ns	
RAS Hold Time	t_{RSH}	10		12		12		13		ns	
RAS Hold Time Referenced to $\overline{\text{OE}}$	t_{ROH}	7		8		8		9		ns	
$\overline{\text{CAS}}$ Hold Time	t_{CSH}	25		30		34		40		ns	
$\overline{\text{CAS}}$ Pulse Width	t_{CAS}	4.5		6	10K	6	10K	7	10K	ns	
$\overline{\text{RAS}}$ to $\overline{\text{CAS}}$ Delay Time	t_{RCD}	13		17	24	18	28	18	33	ns	
$\overline{\text{RAS}}$ to Column Address Delay Time	t_{RAD}	10		12	17	13	20	13	23	ns	7
$\overline{\text{CAS}}$ to RAS Precharge Time	t_{CRP}	5		5		5		5		ns	
Row Address Set-Up Time	t_{ASR}	0		0		0		0		ns	
Row Address Hold Time	t_{RAH}	6		7		8		8		ns	
Column Address Set-Up Time	t_{ASC}	0		0		0		0		ns	
Column Address Hold Time	t_{CAH}	6		6		6		6		ns	
Column Address to $\overline{\text{RAS}}$ Lead Time	t_{RAL}	15		18		20		23		ns	
Column Address Hold Time Referenced to $\overline{\text{RAS}}$	t_{AR}	26		30		34		39		ns	
Read Command Set-Up Time	t_{RCS}	0		0		0		0		ns	
Read Command Hold Time Referenced to $\overline{\text{CAS}}$	t_{RCH}	0		0		0		0		ns	4
Read Command Hold Time Referenced to $\overline{\text{RAS}}$	t_{RRH}	0		0		0		0		ns	4
Write Command Set-Up Time	t_{WCS}	0		0		0		0		ns	8,9
Write Command Hold Time	t_{WCH}	6		6		6		6		ns	
Write Command Pulse Width	t_{WCP}	6		6		6		6		ns	

AC Characteristics

Parameter	Symbol	30		35		40		45		Unit	Notes
		Min.	Max.	Min.	Max.	Min.	Max.	Min.	Max.		
Write Command to $\overline{\text{RAS}}$ Lead Time	t_{RWL}	10		11		12		12		ns	
Write Command to $\overline{\text{CAS}}$ Lead Time	t_{CWL}	10		11		12		12		ns	
Data Set-Up Time	t_{DS}	0		0		0		0		ns	
Data Hold Time	t_{DH}	6		7		8		8		ns	
Data Hold Time Referenced to $\overline{\text{RAS}}$	t_{DHR}	26		31		36		41		ns	
$\overline{\text{RAS}}$ to $\overline{\text{WE}}$ Delay Time	t_{RWD}	44		49		54		59		ns	
$\overline{\text{CAS}}$ to $\overline{\text{WE}}$ Delay Time	t_{CWD}	22		23		24		24		ns	
Column Address to $\overline{\text{WE}}$ Delay Time	t_{AWD}	25		30		32		34		ns	
$\overline{\text{RAS}}$ to $\overline{\text{CAS}}$ Precharge Time	t_{RPC}	0		0		0		0		ns	
Access Time from $\overline{\text{CAS}}$ Precharge	t_{CPA}		17		20		22		24	ns	
EDO Page Mode Cycle Time	t_{PC}	12		13		15		18		ns	
EDO Page Mode Read-Modify-Write Cycle Time	t_{PRWC}	43		47		50		52		ns	
$\overline{\text{CAS}}$ Precharge Time (EDO Page Mode)	t_{CP}	4.5		5		5		7		ns	
$\overline{\text{RAS}}$ Pulse Width (EDO Page Mode Only)	t_{RASP}	30	100k	35	100k	40	100k	45	100k	ns	
Access Time from $\overline{\text{OE}}$	t_{OEA}		10		11		12		12	ns	
$\overline{\text{OE}}$ to Data Delay Time	t_{OED}	8		8		8		8		ns	
$\overline{\text{OE}}$ to Output High-Z	$t_{\text{O EZ}}$	3	8	3	8	3	8	3	8	ns	
$\overline{\text{OE}}$ Command Hold Time	t_{OEH}	6		6		7		7		ns	
Data Output Hold after $\overline{\text{CAS}}$ low	t_{DOH}	3		3		3		5		ns	
$\overline{\text{RAS}}$ to Output High-Z	t_{REZ}	3	8	3	8	3	8	3	8	ns	
$\overline{\text{WE}}$ to Output High-Z	t_{WEZ}	3	10	3	10	3	10	3	10	ns	
$\overline{\text{OE}}$ to $\overline{\text{CAS}}$ Hold Time	t_{OCH}	8		8		8		8		ns	
$\overline{\text{CAS}}$ Hold Time to $\overline{\text{OE}}$	t_{CHO}	8		8		8		8		ns	
$\overline{\text{OE}}$ Precharge Time	t_{OEP}	8		8		8		8		ns	
$\overline{\text{CAS}}$ Set-Up Time for $\overline{\text{CAS}}$ -before- $\overline{\text{RAS}}$ Cycle	t_{CSR}	10		10		10		10		ns	
$\overline{\text{CAS}}$ Hold Time for $\overline{\text{CAS}}$ -before- $\overline{\text{RAS}}$ Cycle	t_{CHR}	10		10		10		10		ns	
Transition Time	t_{T}	1.5	50	2	50	2	50	2	50	ns	
Refresh Period	t_{REF}		4		4		4		4	ms	

Notes:

1. Measure with a load equivalent to 1TTL inputs and 50 pF.
2. Assumes that $t_{\text{RCD}} \leq t_{\text{RCD}}(\text{max.})$. If t_{RCD} is greater than $t_{\text{RCD}}(\text{max.})$, access time will be t_{AA} dominant.
3. Assumes that $t_{\text{RAD}} \leq t_{\text{RAD}}(\text{max.})$. If t_{RAD} is greater than $t_{\text{RCD}}(\text{max.})$, access time will be controlled by t_{CAC} .
4. Either t_{RRH} or t_{RCH} must be satisfied for a Read Cycle.
5. Access time is determined by the longest of t_{AA} , t_{CAC} and t_{CPA} .
6. Assumes that $t_{\text{RAD}} \geq t_{\text{RAD}}(\text{max.})$.
7. Operation within the $t_{\text{RAD}}(\text{max.})$ limit ensures that $t_{\text{RAC}}(\text{max.})$ can be met. $t_{\text{RAD}}(\text{max.})$ is specified as a reference point only. If t_{RAD} is greater than the specified $t_{\text{RAD}}(\text{max.})$ limit, the access time is controlled by t_{AA} and t_{CAC} .
8. t_{WCS} , t_{RWD} , t_{AWD} and t_{CWD} are not restrictive operating parameters.
9. $t_{\text{WCS}}(\text{min.})$ must be satisfied in an Early Write Cycle.
10. t_{DS} and t_{DH} are referenced to the latter occurrence of $\overline{\text{CAS}}$ or $\overline{\text{WE}}$.
11. t_{T} is measured between $V_{\text{IH}}(\text{min.})$ and $V_{\text{IL}}(\text{max.})$. AC-measurements assume $t_{\text{T}} = 2 \text{ ns}$.

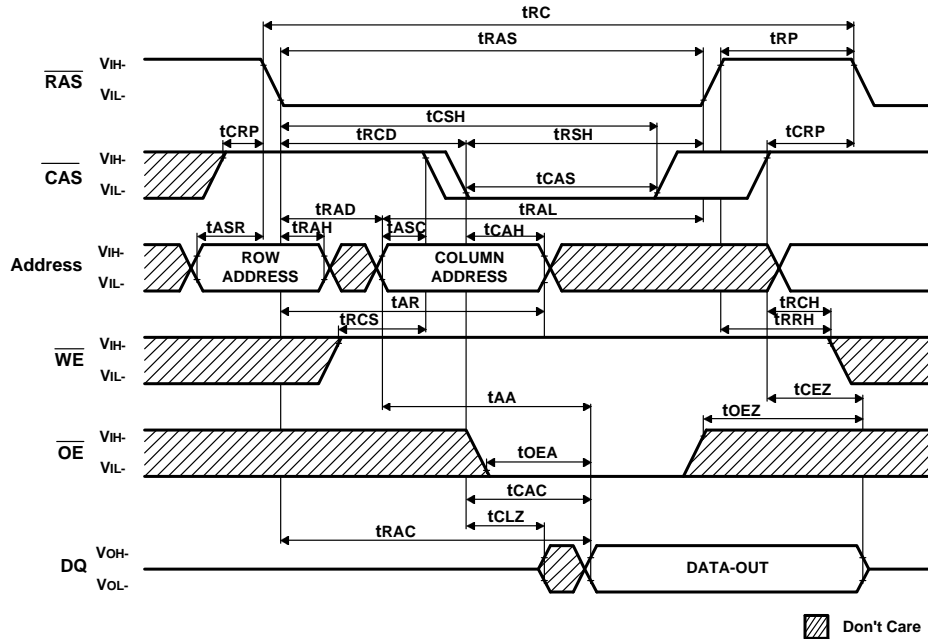
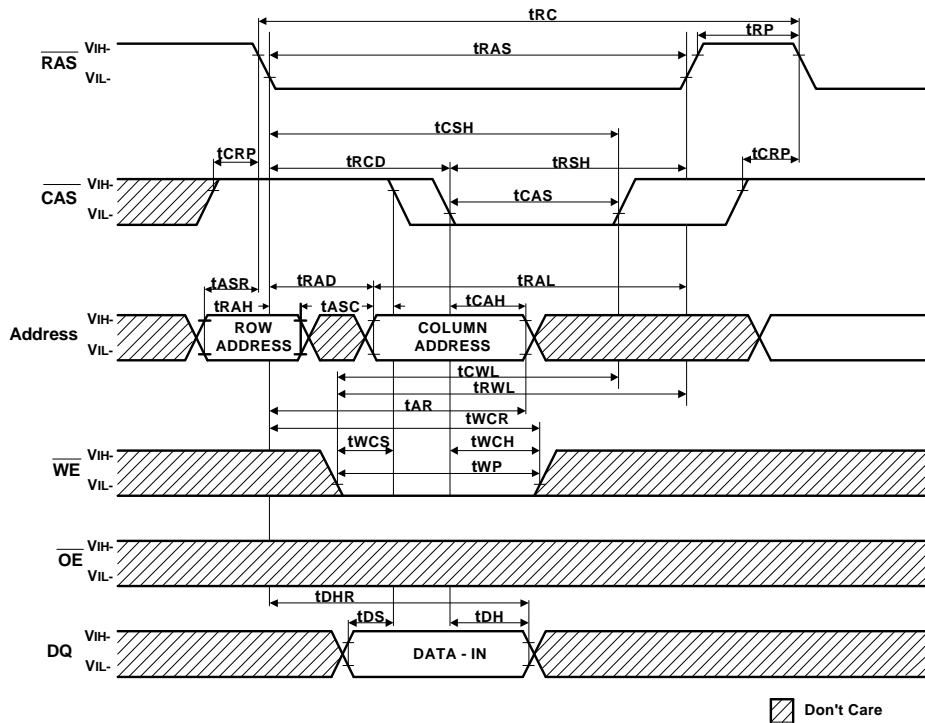
Read Cycle

Early Write Cycle NOTE : D_{OUT} = OPEN

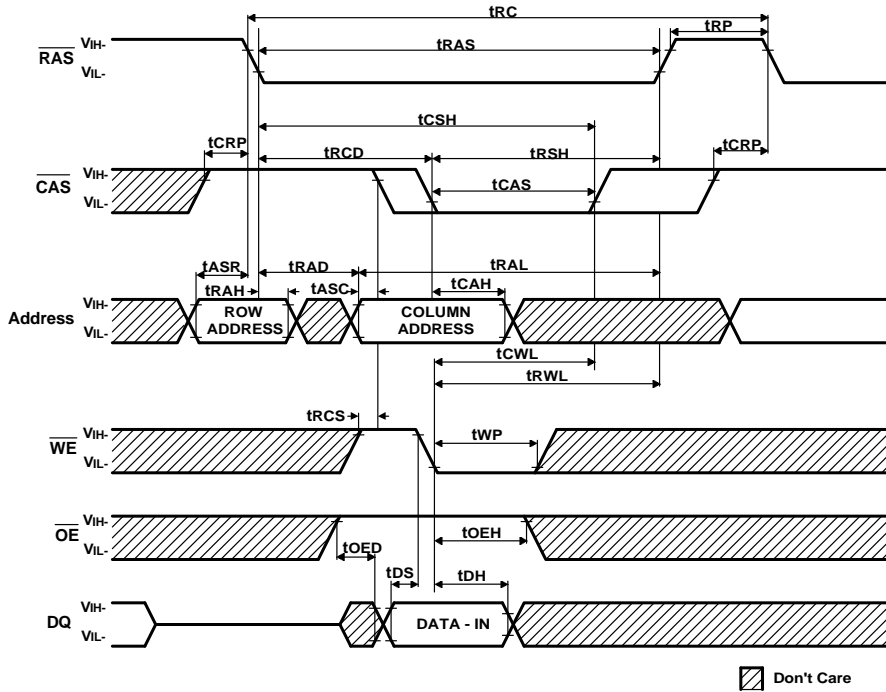
OE Controlled Write Cycle NOTE : D_{OUT} = OPEN

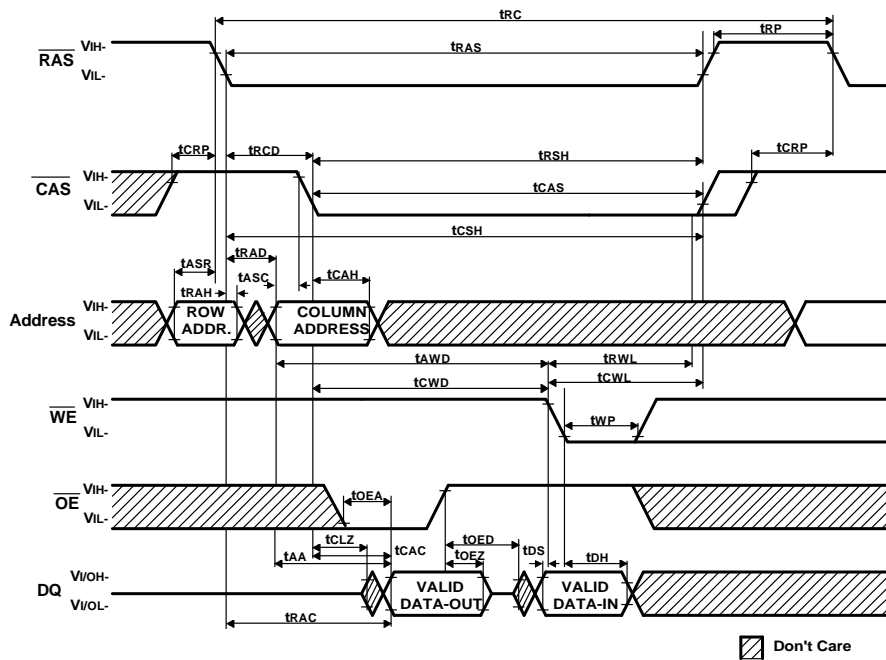

Read - Modify - Write Cycle



EDO Page Mode Read Cycle NOTE : D_{OUT} = OPEN

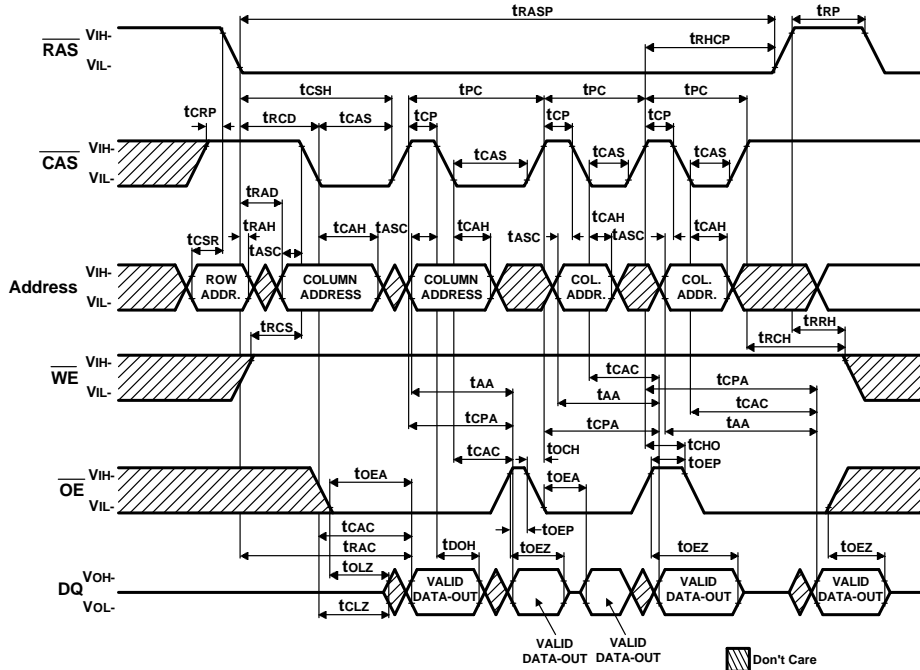

EDO Page Mode Early Write Cycle NOTE : D_{OUT} = OPEN

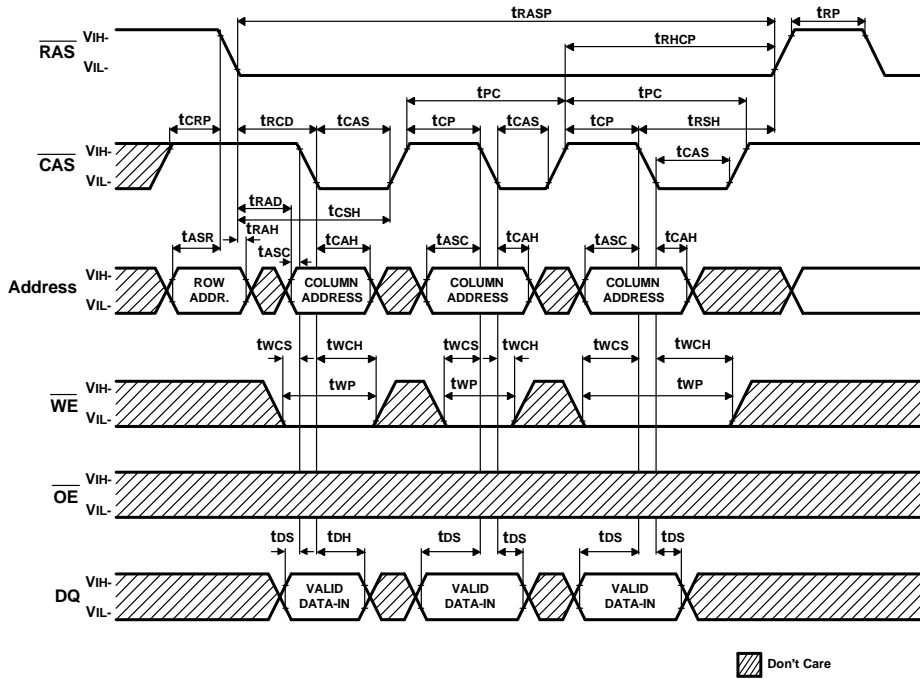

Hidden Refresh Cycle (Write) NOTE : D_{OUT} = OPEN

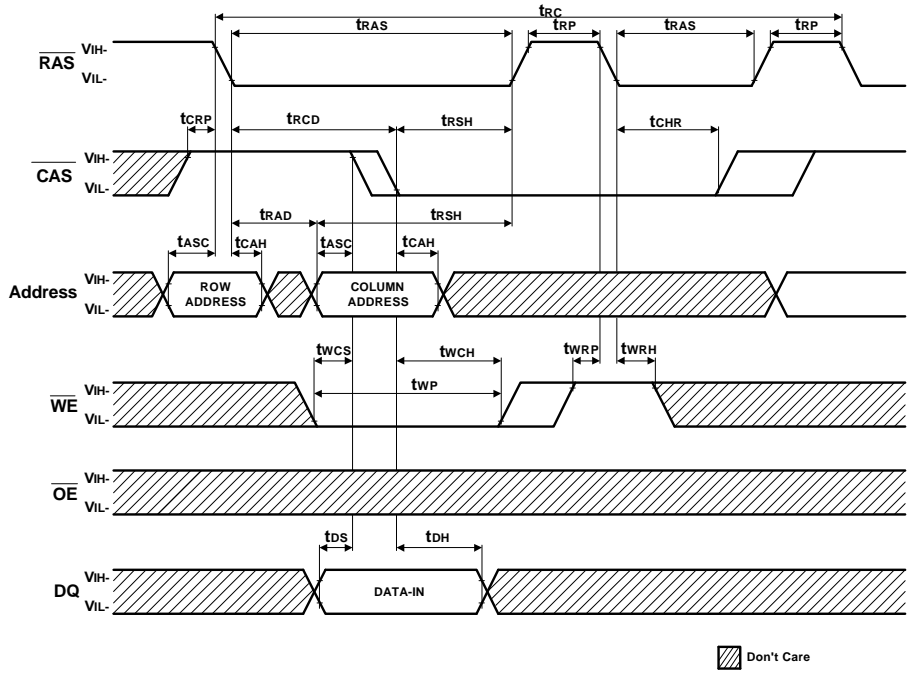

CAS-Before RAS Refresh Counter Test Cycle

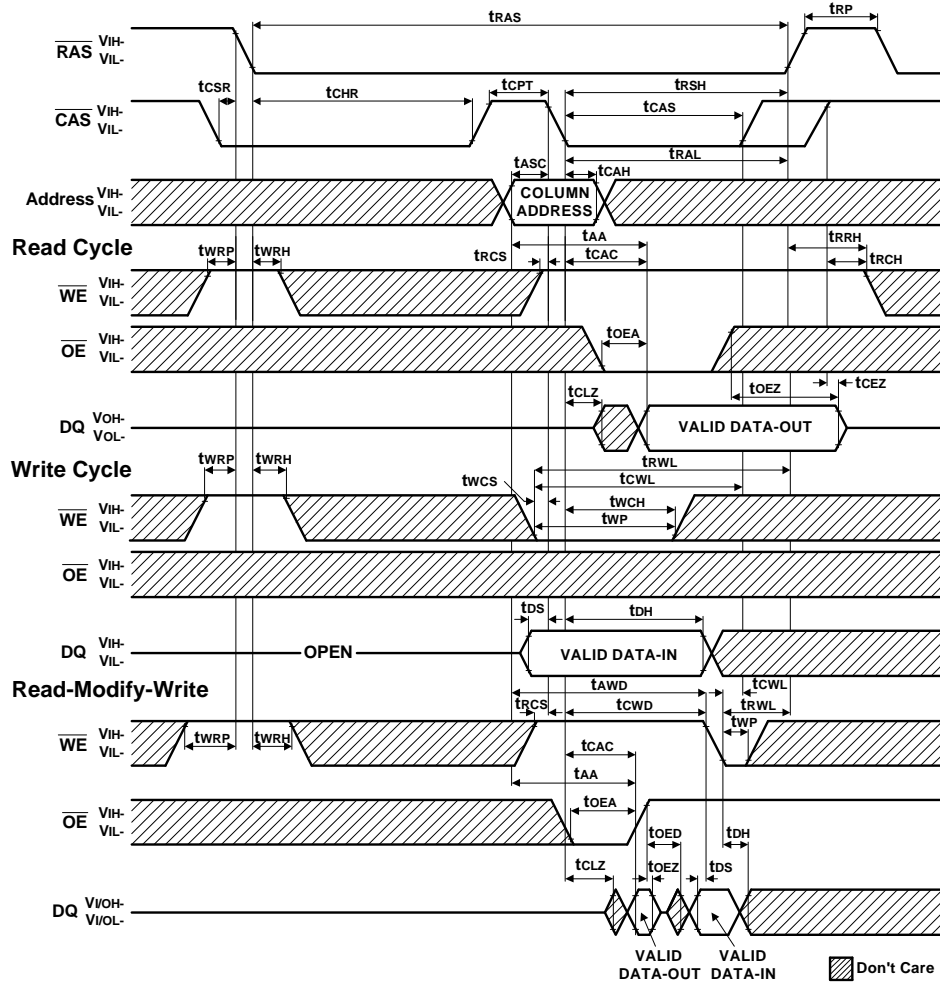

Ordering Information

Part Number	SPEED	POWER	FEATURE	PACKAGE
GLT41216-30J4	30ns	Normal	EDO	SOJ 400mil 40L
GLT41216-35J4	35ns	Normal	EDO	SOJ 400mil 40L
GLT41216-40J4	40ns	Normal	EDO	SOJ 400mil 40L
GLT41216-45J4	45ns	Normal	EDO	SOJ 400mil 40L
GLT41216-30TC	30ns	Normal	EDO	TSOP 400mil 44L
GLT41216-35TC	35ns	Normal	EDO	TSOP 400mil 44L
GLT41216-40TC	40ns	Normal	EDO	TSOP 400mil 44L
GLT41216-45TC	45ns	Normal	EDO	TSOP 400mil 44L

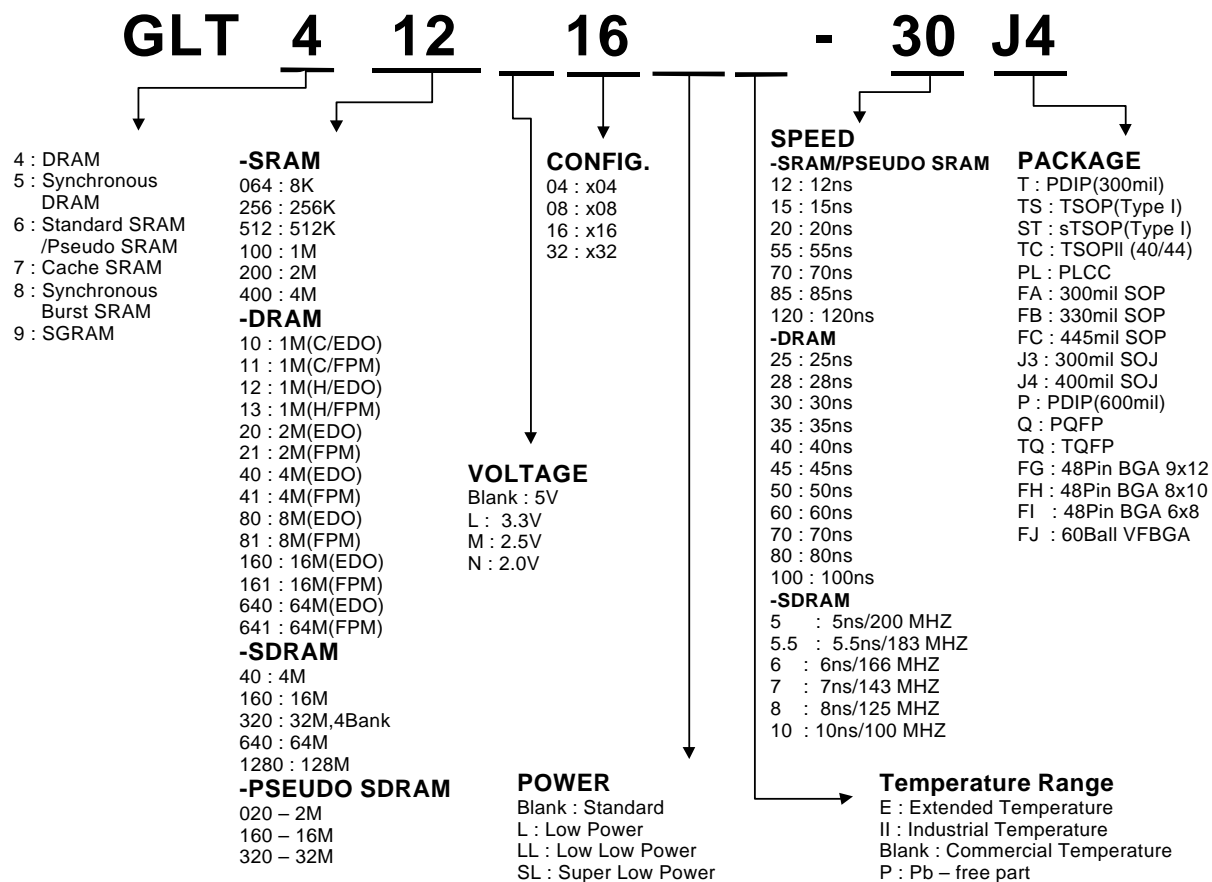
Parts Numbers (Top Mark) Definition :

Package Information

400mil 40 pin Small Outline J-form Package (SOJ)

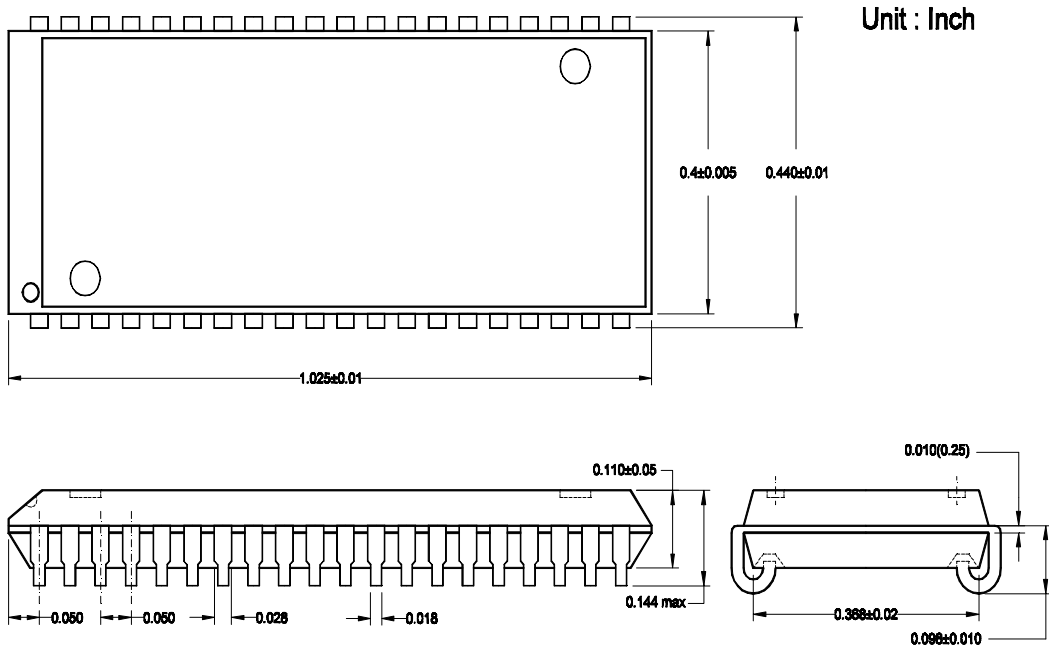

40/44 Lead Thin Small Outline Package TSOP(Type II)

