

Features :

- * 4,194,304 words by 4 bits organization.
- * Fast access time and cycle time
- * Low power dissipation.
- * Read-Modify-Write, RAS-Only Refresh, CAS-Before-RAS Refresh, Hidden Refresh.
- * 2,048 refresh cycles per 32ms.
- * Available in 300 mil 26(24) SOJ and TSOPII.
- * 2.0V±0.2V Vcc Power Supply voltage.
- * All inputs and Outputs are LVTTTL compatible.
- * Extended Data-Out (EDO) Page access cycle.
- * Self-refresh Capability.(S-Version).

Description :

The GLT4160N04 is a high-performance CMOS dynamic random access memory containing 16,777,216 bits organized in a x4 configuration. The GLT4160N04 offers page cycle access with Extended Data Output. The GLT4160N04 has 11 row- and 11 column-addresses, and accepts 2048-cycle refresh in 32 ms.

The GLT4160N04 provides EDO PAGE MODE operation which allows for fast data access within a row-address defined boundary, up to 2048 x 4 bits with cycle times as short as 45ns.

HIGH PERFORMANCE	100
Max. <u>RAS</u> Access Time, (t_{RAC})	100 ns
Max. Column Address Access Time, (t_{AA})	50 ns
Min. Extended Data Out Page Mode Cycle Time, (t_{PC})	45 ns
Min. Read/Write Cycle Time, (t_{RC})	190 ns
Max. <u>CAS</u> Access Time (t_{CAC})	25 ns

Pin Configuration :

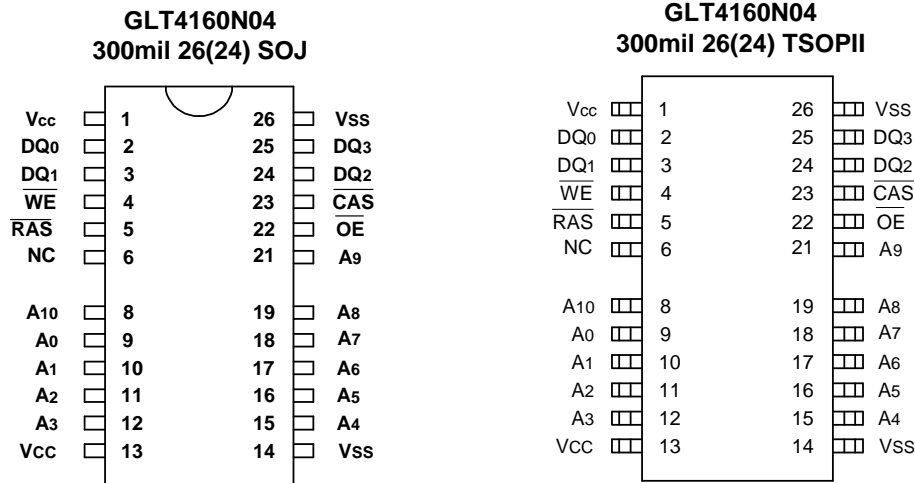

Pin Descriptions:

Name	Function
A ₀ - A ₁₀	Address Inputs
$\overline{\text{RAS}}$	Row Address Strobe
$\overline{\text{CAS}}$	Column Address Strobe
$\overline{\text{WE}}$	Write Enable
$\overline{\text{OE}}$	Output Enable
DQ ₀ - DQ ₃	Data Inputs / Outputs
V _{CC}	+2V Power Supply
V _{SS}	Ground
NC	No Connection

Absolute Maximum Ratings*

Operating Temperature, T_A (ambient)
0°C to +70°C
 For Extended Temperature.....-20°C to 85°C
 Storage Temperature(plastic).....-55°C to +150°C
 Voltage Relative to V_{SS}.....-0.5V to + 3.5V
 Short Circuit Output Current.....20mA
 Power Dissipation.....1.0W

*Note: Operation above Absolute Maximum Ratings can adversely affect device reliability.

Capacitance*

T_A=25°C, V_{CC}=2V±0.2V, V_{SS}=0V

Symbol	Parameter	Max.	Unit
C _{IN1}	Address Input	5	pF
C _{IN2}	RAS, CAS, WE, OE	7	pF
C _{OUT}	Data Input/Output	7	pF

*Note: Capacitance is sampled and not 100% tested

Electrical Specifications

- All voltages are referenced to GND.
- After power up, wait more than 200μs and then, execute eight $\overline{\text{CAS}}$ -before- $\overline{\text{RAS}}$ or $\overline{\text{RAS}}$ -only refresh cycles as dummy cycles to initialize internal circuit.

Block Diagram :

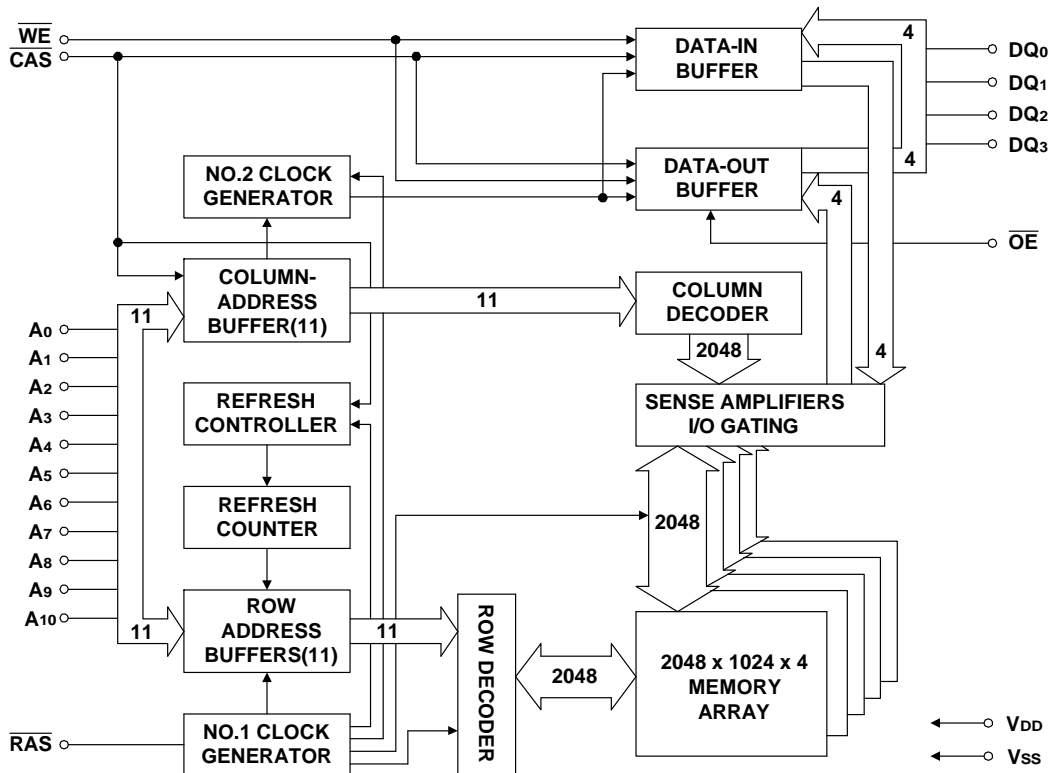

G-Link Technology Corporation, Taiwan

Web : www.glink.com.tw Email : sales@glink.com.tw

TEL : 886-2-27968078

Truth Table:

Function		RAS	CAS	WE	OE	ADDRESS		DATA-IN/OUT
						t _R	t _C	DQ1-DQ4
Standby		H	H→X	X	X	X	X	High-Z
READ		L	L	H	L	ROW	COL	Data-Out
EARLY WRITE		L	L	L	X	ROW	COL	Data-In
READ WRITE		L	L	H→L	L→H	ROW	COL	Data-Out,Data-In
EDO-PAGE-MODE READ	1st Cycle	L	H→L	H	L	ROW	COL	Data-Out
	2nd cycle	L	H→L	H	L	n/a	COL	Data-Out
EDO-PAGE-MODE EARLY-WRITE	1st Cycle	L	H→L	L	X	ROW	COL	Data-In
	2nd cycle	L	H→L	L	X	n/a	COL	Data-In
EDO-PAGE-MODE READ-WRITE	1st Cycle	L	H→L	H→L	L→H	ROW	COL	Data-Out,Data-In
	2nd cycle	L	H→L	H→L	L→H	n/a	COL	Data-Out,Data-In
RAS -ONLY REFRESH		L	H	X	X	ROW	n/a	High-Z
HIDDEN REFRESH	READ	L→H→L	L	H	L	ROW	COL	Data-Out
	WRITE	L→H→L	L	L	X	ROW	COL	Data-In
CBR REFRESH		H→L	L	H	X	X	X	High-Z
SELF REFRESH		H→L	L	H	X	X	X	High-Z

DC and Operating Characteristics (1-2)
 $T_A = 0^{\circ}\text{C to } 70^{\circ}\text{C, } -20^{\circ}\text{C to } 85^{\circ}\text{C } V_{CC}=2\text{V}\pm 0.2\text{V, } V_{SS}=0\text{V, unless otherwise specified.}$

Sym.	Parameter	Test Conditions	Access Time	Min.	Typ	Max.	Unit	Notes
I_{LI}	Input Leakage Current (any input pin)	$0\text{V} \leq V_{IN} \leq V_{CC}+0.3\text{V}$ (All other pins not under test=0V)		-5		+5	μA	
I_{LO}	Output Leakage Current (for High-Z State)	$0\text{V} \leq V_{out} \leq V_{CC}$ Output is disabled (Hiz)		-5		+5	μA	
I_{CC1}	Operating Current, Random READ/WRITE	$t_{RC} = t_{RC} (\text{min.})$	$t_{RAC} = 100\text{ns}$			40	mA	1,2
I_{CC2}	Standby Current, (TTL)	$\overline{\text{RAS}}, \overline{\text{CAS}}$ at V_{IH} other inputs $\geq V_{SS}$				1	mA	
I_{CC3}	Refresh Current, RAS -Only	$\overline{\text{RAS}}$ cycling, $\overline{\text{CAS}}$ at V_{IH} $t_{RC} = t_{RC} (\text{min.})$	$t_{RAC} = 100\text{ns}$			40	mA	2
I_{CC4}	Operating Current, EDO Page Mode	$\overline{\text{RAS}}$ at V_{IL} , $\overline{\text{CAS}}$ address cycling: $t_{PC}=t_{PC}(\text{min.})$	$t_{RAC} = 100\text{ns}$			40	mA	1,2
I_{CC5}	Refresh Current, CAS Before RAS	$\overline{\text{RAS}}, \overline{\text{CAS}}$ address cycling: $t_{RC}=t_{RC} (\text{min.})$	$t_{RAC} = 100\text{ns}$			40	mA	1
I_{CC6}	Standby Current, (CMOS)	$\overline{\text{RAS}} \geq V_{CC}-0.2\text{V},$ $\overline{\text{CAS}} \geq V_{CC}-0.2\text{V},$ All other inputs V_{SS}				200	μA	1
I_{CC7}	Self refresh Current	$\overline{\text{RAS}} = \overline{\text{CAS}} = 0.2\text{V},$ $\overline{\text{WE}} = \overline{\text{OE}} = A_0 \sim A_{10} = V_{CC}-0.2\text{V}$ or 0.2V $DQ_0 \sim DQ_3 = V_{CC}-0.2\text{V}, 0.2\text{V}$ or Open				200	μA	
V_{IL}	Input Low Voltage			-0.2		+0.6	V	3
V_{IH}	Input High Voltage			1.6		$V_{CC}+0.2$	V	4
V_{OL}	Output Low Voltage	$I_{OL} = 2\text{mA}$				0.6	V	
V_{OH}	Output High Voltage	$I_{OH} = -2\text{mA}$		1.6			V	

Notes:

- I_{CC} is dependent on output loading when the device output is selected. Specified $I_{CC}(\text{max.})$ is measured with the output open.
- I_{CC} is dependent upon the number of address transitions specified $I_{CC}(\text{max.})$ is measured with a maximum of one transition per address cycle in random Read/Write and EDO Fast Page Mode.
- Specified $V_{IL}(\text{min.})$ is steady state operation. During transitions $V_{IL}(\text{min.})$ may undershoot to -0.9V for a period not to exceed 10ns. All AC parameters are measured with $V_{IL}(\text{min.}) \geq V_{SS}$ and $V_{IH}(\text{max.}) \leq V_{CC}$.
- Specified $V_{IH}(\text{max.})$ is steady state operation. During transitions $V_{IH}(\text{max.})$ may overshoot to $V_{CC}+0.9\text{V}$ for a period not to exceed 10ns. All AC parameters are measured with $V_{IL}(\text{min.}) \geq V_{SS}$ and $V_{IH}(\text{max.}) \leq V_{CC}$.

G-Link Technology Corporation, Taiwan

 Web : www.glink.com.tw Email : sales@glink.com.tw

TEL : 886-2-27968078

AC Characteristics
 $T_A = 0^\circ\text{C to } 70^\circ\text{C}, -20^\circ\text{C to } 85^\circ\text{C}$ $V_{CC} = 2\text{ V} \pm 0.2\text{V}$, $V_{IH}/V_{IL} = 1.7/0.4\text{ V}$, $V_{OH}/V_{OL} = 1.4/0.6\text{V}$

 An initial pause of 200 μs and 8 CAS-before-RAS or RAS-only refresh cycles are required after power-up.

Parameter	Symbol	100		Unit	Notes
		Min.	Max.		
Read or Write Cycle Time	t_{RC}	190		ns	
Read Modify Write Cycle Time	t_{RWC}	245		ns	
RAS Precharge Time	t_{RP}	80		ns	
RAS Pulse Width	t_{RAS}	100	10k	ns	
Access Time from RAS	t_{RAC}		100	ns	1,2,3
Access Time from CAS	t_{CAC}		25	ns	1,5,10
Access Time from Column Address	t_{AA}		50	ns	1,5,6
CAS to Output Low-Z	t_{CLZ}	5		ns	
CAS to Output High-Z	t_{CEZ}	5	25	ns	
RAS Hold Time	t_{RSH}	25		ns	
CAS Hold Time	t_{CSH}	100		ns	
CAS Pulse Width	t_{CAS}	25	10k	ns	
RAS to CAS Delay Time	t_{RCD}	25	75	ns	
RAS to Column Address Delay Time	t_{RAD}	20	50	ns	7
CAS to RAS Precharge Time	t_{CRP}	10		ns	
Row Address Set-Up Time	t_{ASR}	0		ns	
Row Address Hold Time	t_{RAH}	15		ns	
Column Address Set-Up Time	t_{ASC}	0		ns	
Column Address Hold Time	t_{CAH}	20		ns	
Column Address to RAS Lead Time	t_{RAL}	50		ns	
Column Address Hold Time Referenced to RAS	t_{AR}	75		ns	
Read Command Set-Up Time	t_{RCS}	0		ns	
Read Command Hold Time Referenced to CAS	t_{RCH}	0		ns	4
Read Command Hold Time Referenced to RAS	t_{RRH}	0		ns	4
Write Command Set-Up Time	t_{WCS}	0		ns	8,9
Write Command Hold Time	t_{WCH}	20		ns	
Write Command Pulse Width	t_{WP}	20		ns	
Write Command to RAS Lead Time	t_{RWL}	25		ns	
Write Command to CAS Lead Time	t_{CWL}	25		ns	

AC Characteristics

Parameter	Symbol	100		Unit	Notes
		Min.	Max.		
Data Set-Up Time	t_{DS}	0		ns	
Data Hold Time	t_{DH}	20		ns	
Data Hold Time Referenced to \overline{RAS}	t_{DHR}	75		ns	
\overline{RAS} to \overline{WE} Delay Time	t_{RWD}	135		ns	
\overline{CAS} to \overline{WE} Delay Time	t_{CWD}	60		ns	
Column Address to \overline{WE} Delay Time	t_{AWD}	80		ns	
\overline{CAS} Precharge to \overline{WE} Delay	t_{CPWD}	85		ns	
\overline{RAS} to \overline{CAS} Precharge Time	t_{RPC}	5		ns	
\overline{CAS} precharge time (\overline{CAS} Before \overline{RAS} counter test cycle)	t_{CPT}	30		ns	
Access Time from \overline{CAS} Precharge	t_{CPA}		55	ns	
EDO Page Mode Cycle Time	t_{PC}	45		ns	
EDO Page Mode Read-Modify-Write Cycle Time	t_{PRWC}	120		ns	
\overline{CAS} Precharge Time (EDO Page Mode)	t_{CP}	10		ns	
\overline{RAS} Pulse Width (EDO Page Mode Only)	t_{RASP}	100	100k	ns	
\overline{RAS} Hold Time from \overline{CAS} precharge	t_{RHCP}	60		ns	
Access Time from \overline{OE}	t_{OEA}		25	ns	8
\overline{OE} to Data Delay Time	t_{OED}	25		ns	
\overline{OE} to Output Low-Z	t_{OLZ}	3		ns	
\overline{OE} to Output High-Z	t_{OEZ}	3	25	ns	
\overline{WE} to Data Delay	t_{WED}	25		ns	
\overline{OE} Command Hold Time	t_{OEH}	25		ns	
Data Output Hold after \overline{CAS} low	t_{DOH}	5		ns	
\overline{RAS} to Output High-Z	t_{REZ}	3	25	ns	
\overline{WE} to Output High-Z	t_{WEZ}	3	25	ns	
\overline{OE} to \overline{CAS} Hold Time	t_{OCH}	5		ns	
\overline{CAS} Hold Time to \overline{OE}	t_{CHO}	5		ns	
\overline{OE} Precharge Time	t_{OEP}	5		ns	
\overline{WE} Puts width (EDO mixed read write cycle)	t_{WPE}	5		ns	
\overline{CAS} Set-Up Time for \overline{CAS} -before- \overline{RAS} Cycle	t_{CSR}	5		ns	

Parameter	Symbol	100		Unit	Notes
		Min.	Max.		
CAS Hold Time for CAS -before- RAS Cycle	t_{CHR}	20		ns	
WE to RAS precharge time (CAS Before RAS refresh)	t_{WRP}	10		ns	
WE to RAS hold time (CAS Before RAS refresh)	t_{WRH}	10		ns	
Transition Time	t_T	2	50	ns	
Refresh Period (2,048 cycles)	t_{REF}		32	ms	
Refresh Period (S-Version)	t_{REFS}		128	ms	
RAS Pulse Width (CAS Before RAS Self refresh)	t_{RASS}	100		μ s	
RAS precharge Time (CAS Before RAS Self refresh)	t_{RPS}	180		ns	
CAS Hold Time (CAS Before RAS Self refresh)	t_{CHS}	-50		ns	

TEST MODE CYCLE

Parameter	Symbol	100		Unit	Notes
		Min.	Max.		
Random read or write cycle time	t_{RC}	195		ns	
Read-modify-write cycle time	t_{RWC}	250		ns	
Access time from \overline{RAS}	t_{RAC}		90	ns	1,2,3,7
Access time from \overline{CAS}	t_{CAC}		30	ns	1,3,7
Access time from column address	t_{AA}		55	ns	1,2,7
\overline{RAS} pulse width	t_{RAS}	105	10k	ns	
\overline{CAS} pulse width	t_{CAS}	30	10k	ns	
\overline{RAS} hold time	t_{RSH}	30		ns	
\overline{CAS} hold time	t_{CSH}	105		ns	
Column address to \overline{RAS} lead time	t_{RAL}	55		ns	
\overline{CAS} to \overline{WE} delay time	t_{CWD}	65		ns	8
\overline{RAS} to \overline{WE} delay time	t_{RWD}	140		ns	8
Column address to \overline{WE} delay time	t_{AWD}	85		ns	8
\overline{CAS} Precharge to \overline{WE} delay time	t_{CPWD}	89		ns	8
EDO Page Mode cycle time	t_{PC}	50		ns	
EDO page mode read-modify-write cycle time	t_{PRWC}	125		ns	
\overline{RAS} Pulse width (EDO page cycle)	t_{RASP}	105	100k	ns	
Access time form \overline{CAS} precharge	t_{CPA}		60	ns	1
\overline{OE} access time	t_{OEA}		30	ns	
\overline{OE} to data delay	t_{OED}	30		ns	
\overline{OE} command hold time	t_{OEH}	30		ns	
Write command set-up time (Test mode in)	t_{WTS}	10		ns	
Write command hold time (Test mode in)	t_{WTH}	10		ns	

Notes:

1. Measure with a load equivalent to one TTL input and 100 pF.
2. Assumes that $t_{RCD} \leq t_{RCD}(\text{max.})$. If t_{RCD} is greater than $t_{RCD}(\text{max.})$, access time will be t_{CAC} dominant.
3. Assumes that $t_{RAD} \leq t_{RAD}(\text{max.})$. If t_{RAD} is greater than $t_{RAD}(\text{max.})$, access time will be controlled by t_{AA} .
4. Either t_{RRH} or t_{RCH} must be satisfied for a Read Cycle.
5. Access time is determined by the longest of t_{AA} , t_{CAC} and t_{CPA} .
6. Assumes that $t_{RAD} \geq t_{RAD}(\text{max.})$.
7. Operation within the $t_{RAD}(\text{max.})$ limit ensures that $t_{RAC}(\text{max.})$ can be met. $t_{RAD}(\text{max.})$ is specified as a reference point only. If t_{RAD} is greater than the specified $t_{RAD}(\text{max.})$ limit, the access time is controlled by t_{CAA} and t_{CAC} .
8. t_{WCS} , t_{RWD} , t_{AWD} and t_{CWD} are not restrictive operating parameters.
9. $t_{WCS}(\text{min.})$ must be satisfied in an Early Write Cycle.
10. t_{DS} and t_{DH} are referenced to the latter occurrence of \overline{CAS} or \overline{WE} .
11. t_T is measured between $V_{IH}(\text{min.})$ and $V_{IL}(\text{max.})$. AC-measurements assume $t_T = 2 \text{ ns}$.

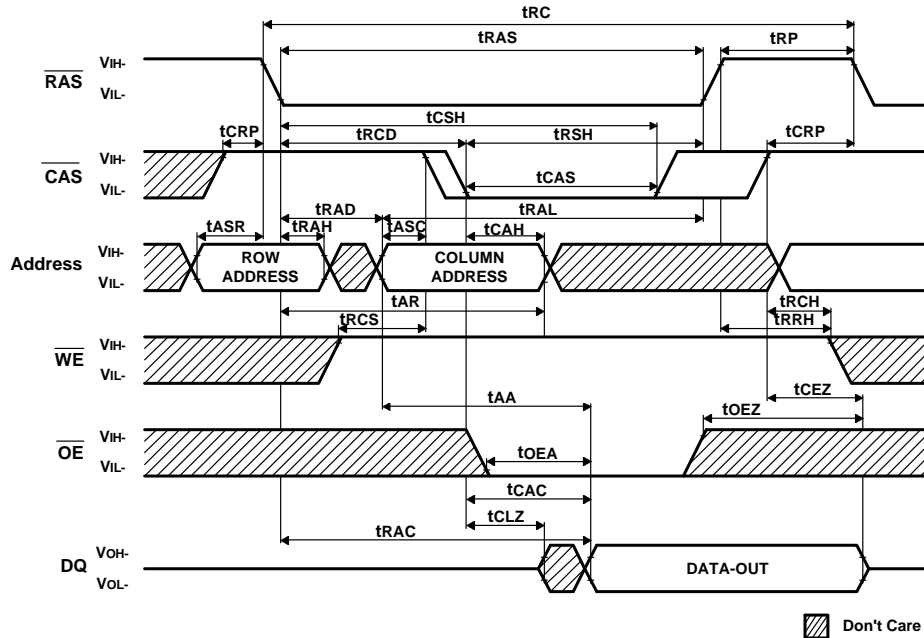
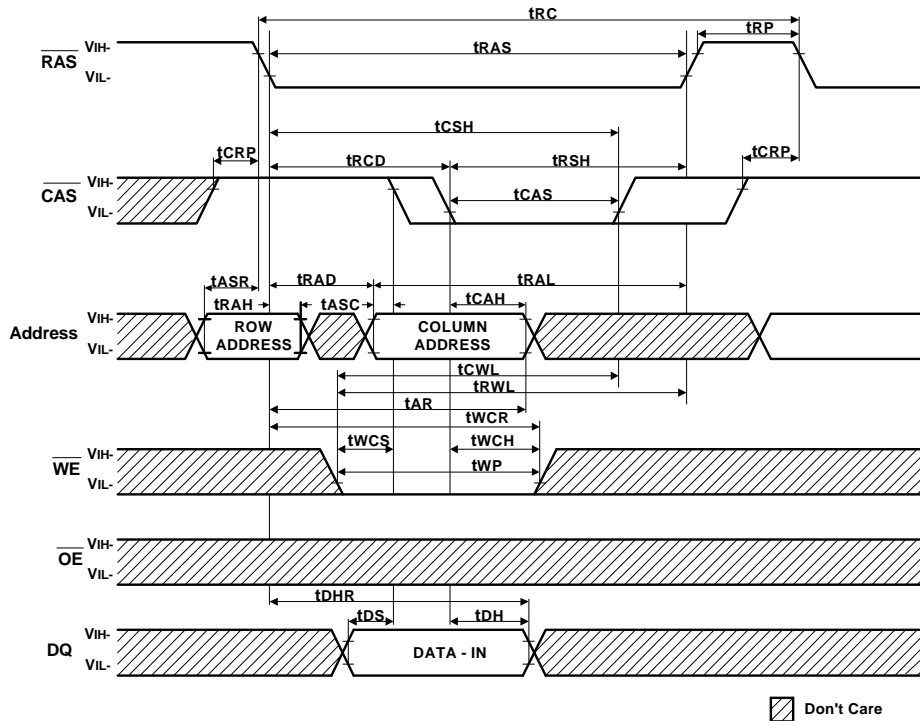
Read Cycle

Early Write Cycle NOTE : D_{OUT} = OPEN

G-Link Technology Corporation, Taiwan

 Web : www.glink.com.tw Email : sales@glink.com.tw

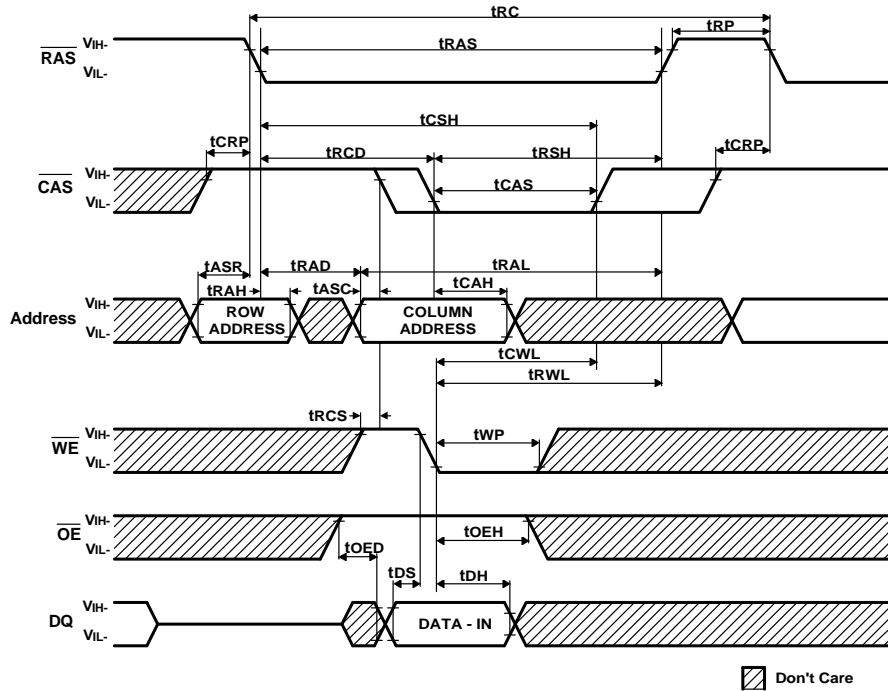
TEL : 886-2-27968078

OE Controlled Write Cycle NOTE : D_{OUT} = OPEN



Read - Modify - Write Cycle

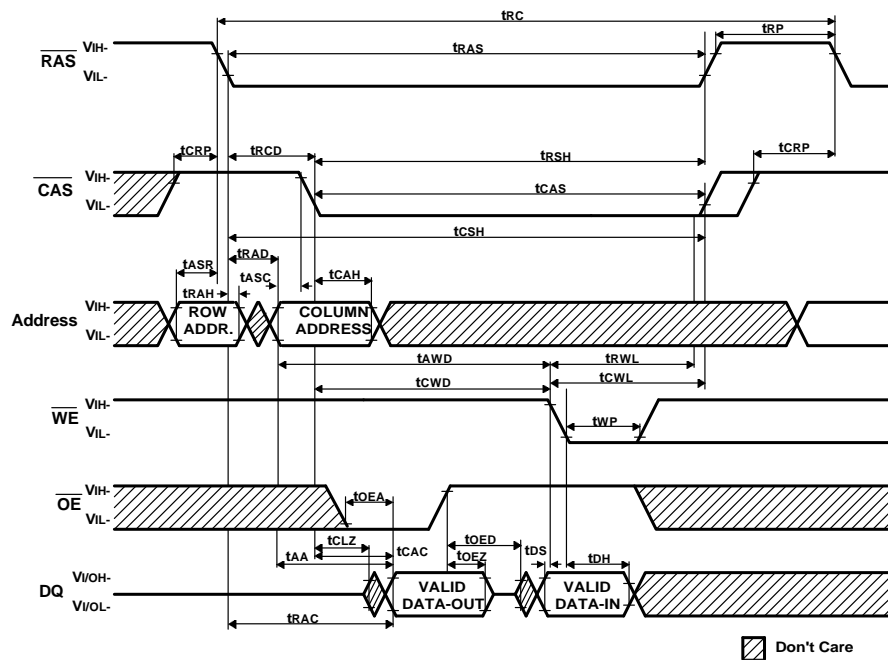

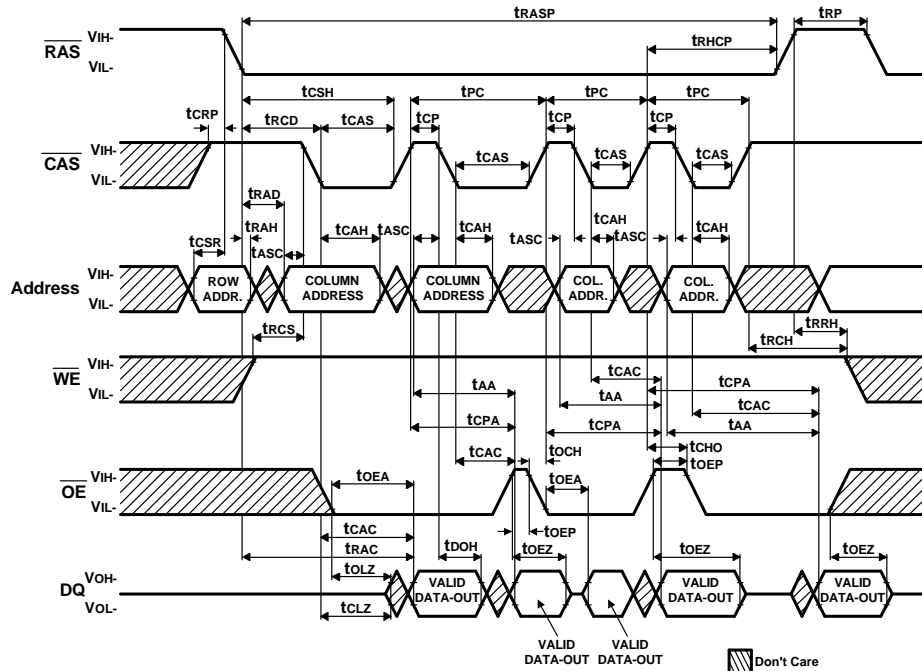
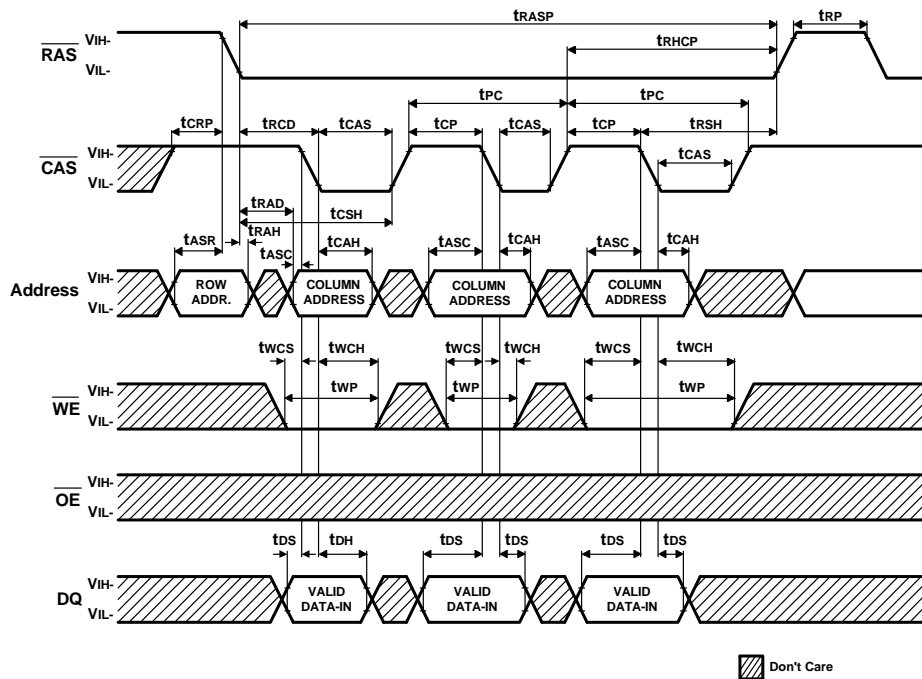
EDO Page Mode Read Cycle NOTE : D_{OUT} = OPEN

EDO Page Mode Early Write Cycle NOTE : D_{OUT} = OPEN

G-Link Technology Corporation, Taiwan

 Web : www.glink.com.tw Email : sales@glink.com.tw

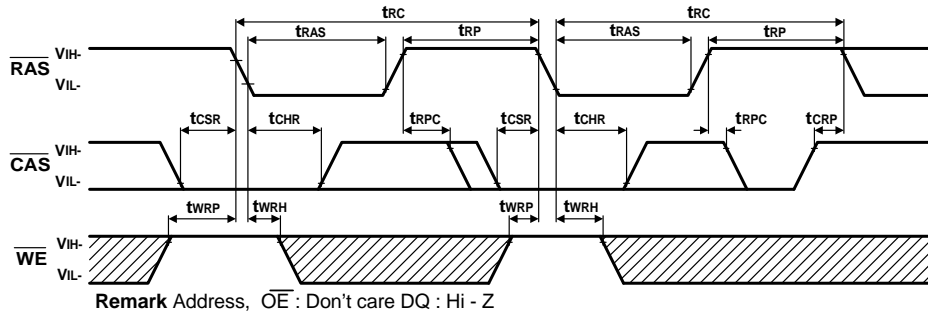
TEL : 886-2-27968078

CAS - Before - RAS Refresh Cycle



RAS-Only Refresh Cycle

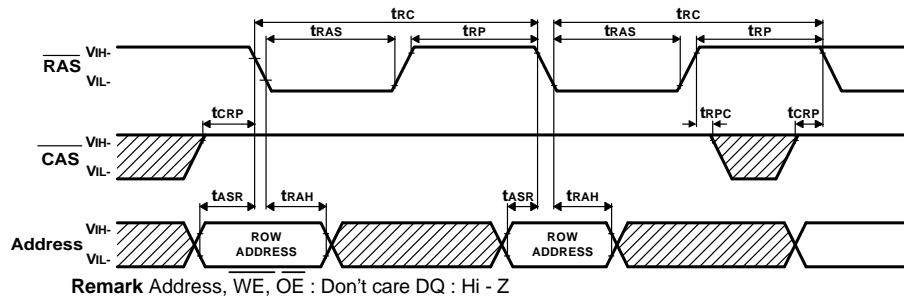

Hidden Refresh Cycle (Read)

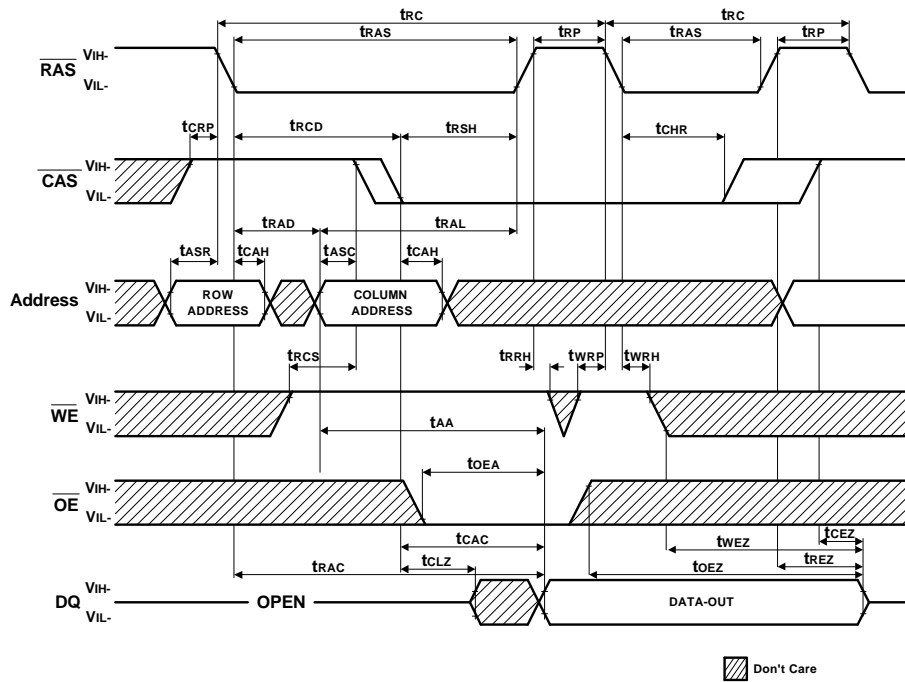

Hidden Refresh Cycle (Write) NOTE : D_{OUT} = OPEN

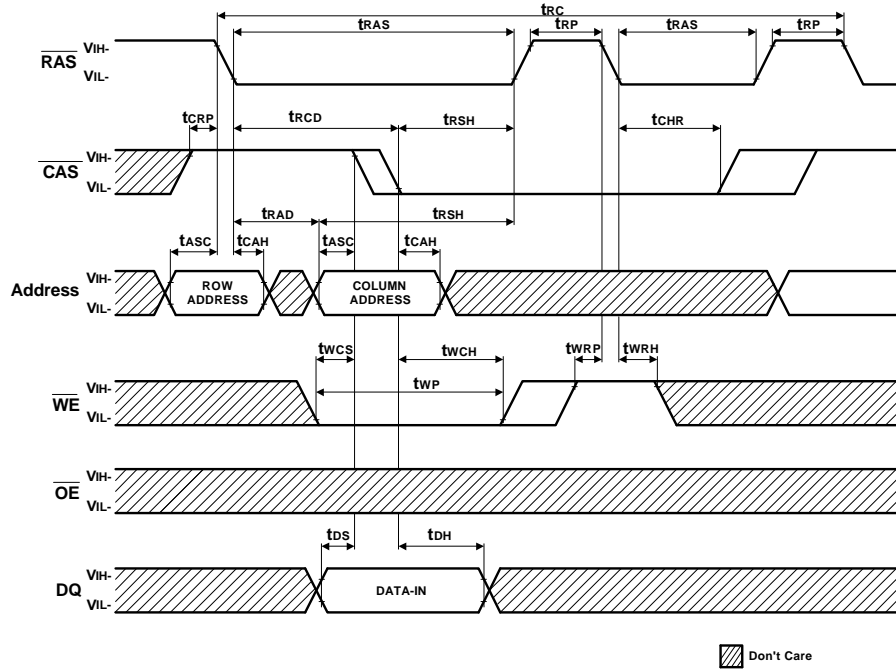

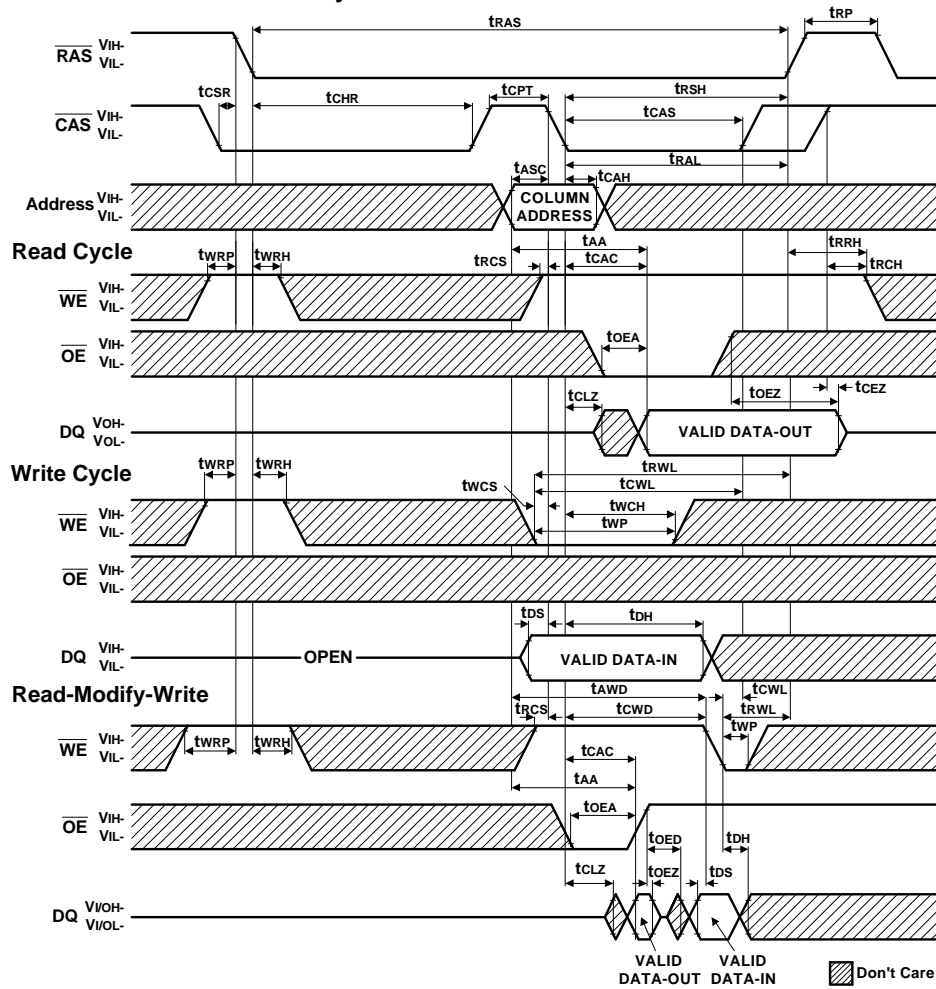
CAS-Before RAS Refresh Counter Test Cycle

Test Mode In Cycle

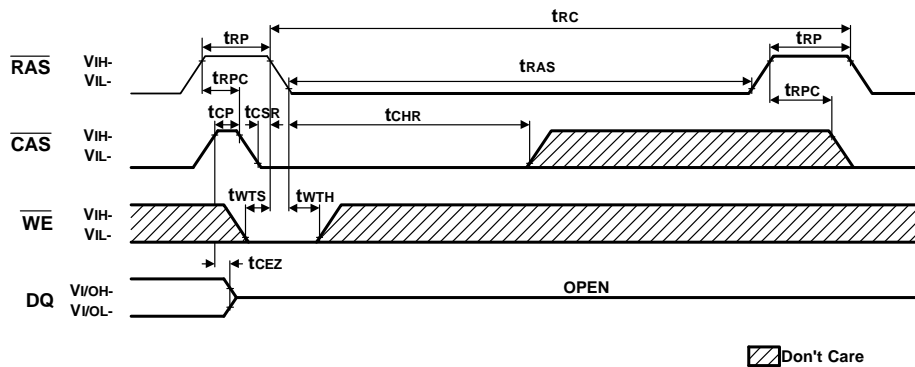

Test Mode

By using the test mode, the test time can be reduced. The reason for this is that, the memory emulates the x 16-bit organization during test mode. Don't care about the input levels of the CAS input A0, A1 .

(1) Setting the mode

Executing the test mode cycle (\overline{WE} , \overline{CAS} before \overline{RAS} refresh cycle) sets the test mode.

(2) Write / read operation

When either a "0" or a "1" is written to the input pin in test mode, this data is written to 16 bits of memory cell.

Next, when the data is read from the output pin at the same address, the cell be checked.

Output = "1" Normal write (all memory cells)

Output = "0" Abnormal write

(3) Refresh

Refresh in the test mode must be performed with the \overline{RAS} / \overline{CAS} cycle or with the \overline{WE} , \overline{CAS} before \overline{RAS} refresh cycle. The \overline{WE} , \overline{CAS} before \overline{RAS} refresh cycle use the same counter as the \overline{CAS} before \overline{RAS} refresh's internal counter.

(4) Mode Cancellation

The test mode is cancelled by executing one cycle of \overline{RAS} only refresh cycle or \overline{CAS} before \overline{RAS} refresh cycle.

CAS-Before-RAS Self Refresh Cycle

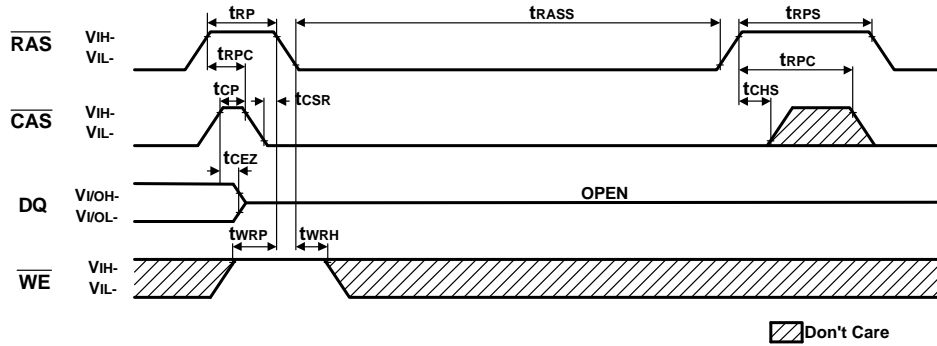

NOTE : \overline{OE} , Address = Don't Care

Ordering Information

Part Number	SPEED	POWER	FEATURE	TEMPERATURE	PACKAGE
GLT4160N04-100J3	100ns	Normal	EDO	Commercial	SOJ 300mil 26(24)L
GLT4160N04E-100J3	100ns	Normal	EDO	Extended	SOJ 300mil 26(24)L
GLT4160N04P-100J3	100ns	Normal	EDO	Commercial	SOJ 300mil 26(24)L
GLT4160N04-100TC	100ns	Normal	EDO	Commercial	TSOPII 300mil 26(24)L
GLT4160N04E-100TC	100ns	Normal	EDO	Extended	TSOPII 300mil 26(24)L
GLT4160N04P-100TC	100ns	Normal	EDO	Commercial	TSOPII 300mil 26(24)L

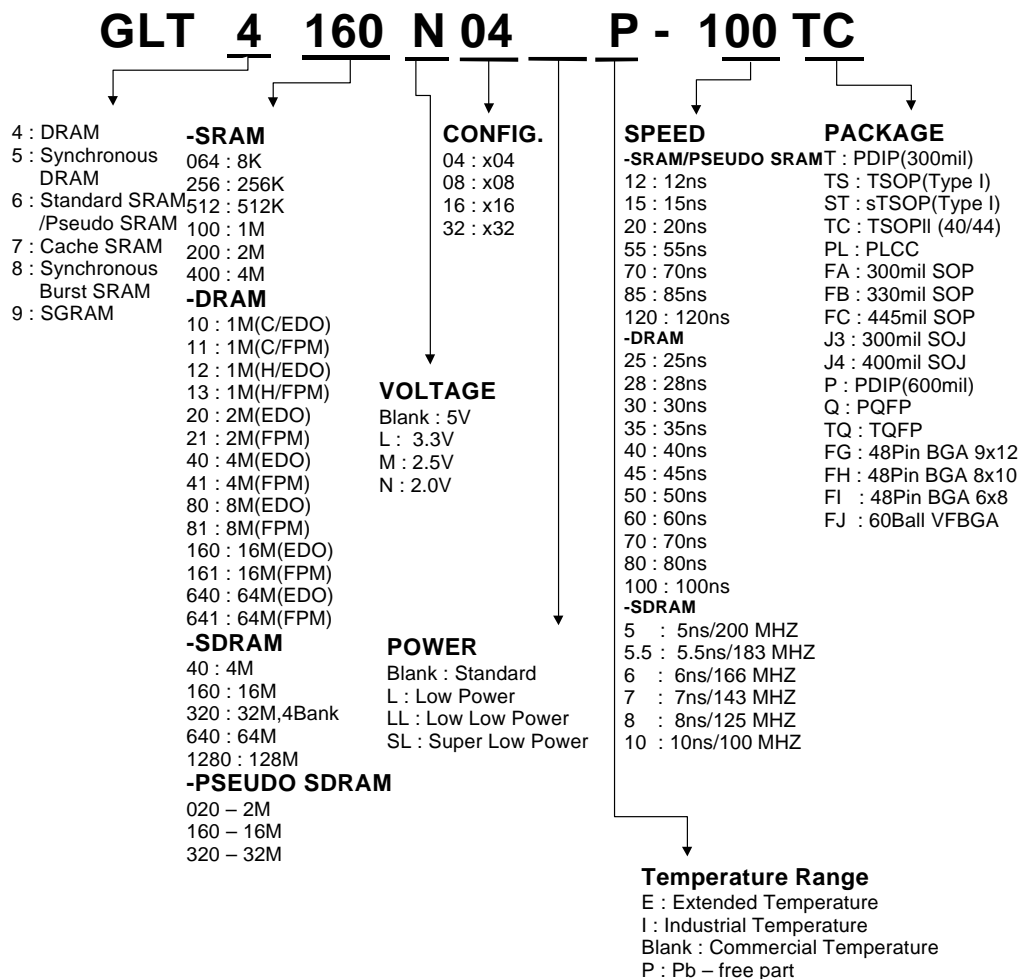
Parts Numbers (Top Mark) Definition :

G-Link Technology Corporation, Taiwan

 Web : www.glink.com.tw Email : sales@glink.com.tw

TEL : 886-2-27968078

Package Information

300mil 24/26 Lead Thin Small Outline Package SOJ

Unit : Inch(mm)

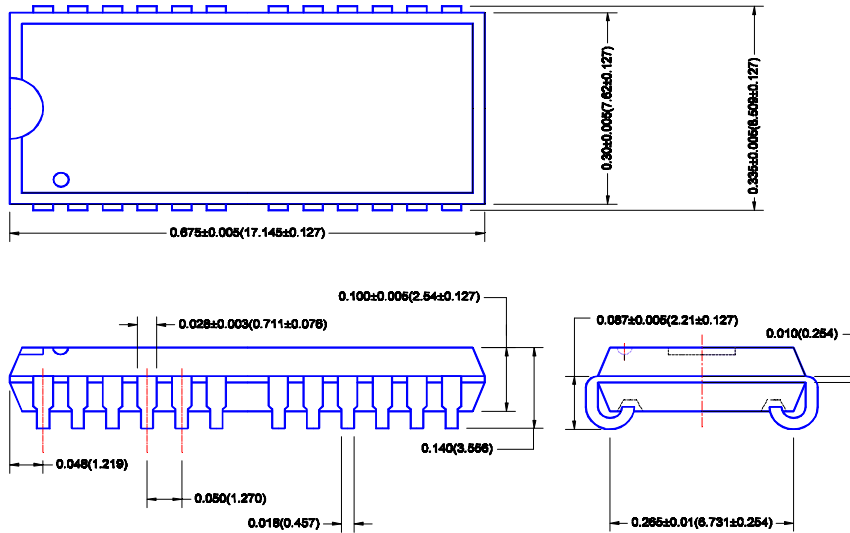

300mil 24/26 Lead Thin Small Outline Package (TSOP) TYPE II

