



SH6614D

4K 4-Bit Microcontroller with LCD Driver

Features

- SH6610C-based single-chip 4-bit microcontroller
- ROM: 4096 X 16 bits
- RAM: 512 X 4 bits
- Operation voltage: 2.4V – 6.0V
- 8 CMOS bi-directional I/O pins
- 4-Level subroutine nesting (include interrupts)
- One 8-bit auto re-load timer/counter
- Wem-up timer for power-on reset
- Powerful interrupt sources:
 - External interrupts ($\overline{INT0}$)
 - Internal interrupt (Timer0)
 - Internal interrupt (Base Timer)
 - Port's falling edge interrupt: PORTB ($\overline{INT1}$)
- 8-bit Base timer
- LCD driver:
 - 240 dots (1/8 duty 1/4 bias) or 136 dots (1/4 duty 1/3 bias)
- LCD used as scan output
- Built-in dual tone PSG with one noise generator
- 2 Clock sources
 - OSC: (code option select crystal or RC type)
 - Crystal oscillator 32.768K
 - RC oscillator: 262K
 - OSCX: (system register selected ceramic or RC type)
 - Ceramic oscillator 455K
 - RC oscillator 1.8M or 2M
- Instruction cycle time:
 - 122.07 μ s for 32.768 KHz crystal
 - 15.27 μ s for 262 KHz RC
 - 8.79 μ s for 455KHz ceramic
 - 2.22 μ s for 1.8 MHz RC
 - 2 μ s for 2.0 MHz RC
- Two low power operation modes: HALT and STOP
- Low power consumption

General Description

SH6614D is a single chip microcontroller integrated with SRAM, timer and dual-tone PSG, LCD driver, and I/O port. This chip builds in a dual-oscillator to enhance the total chip performance.

Pin Configuration

QFP64

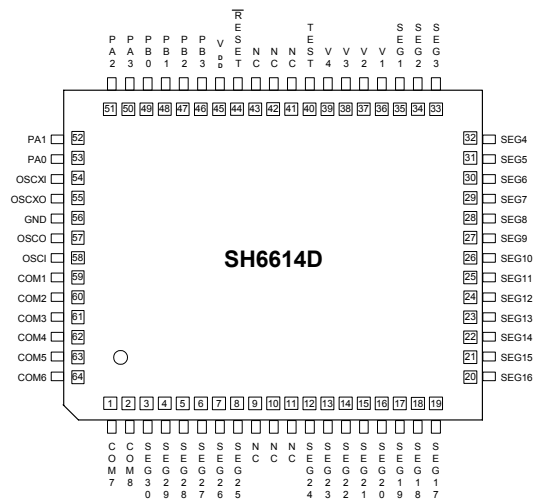



QFP100

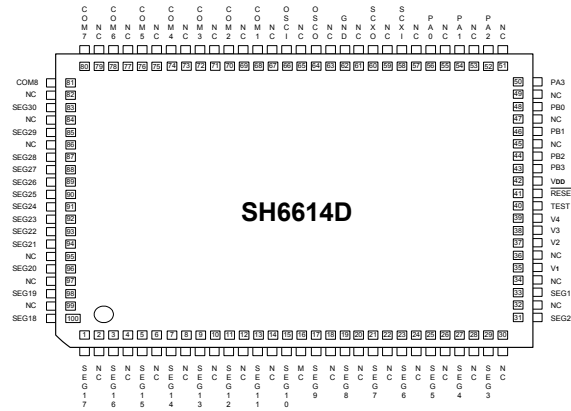

Pad Configuration

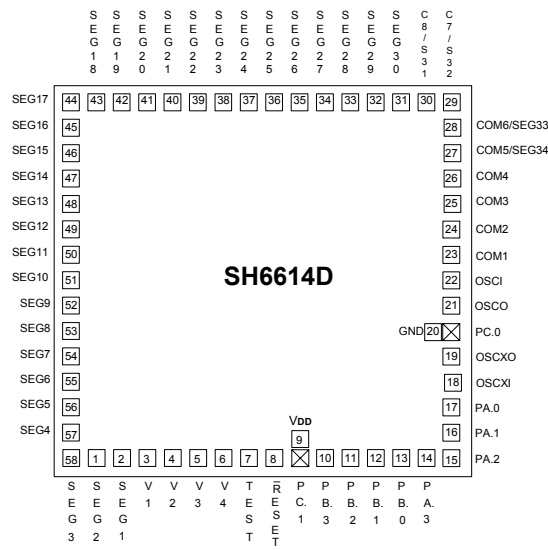



Block Diagram

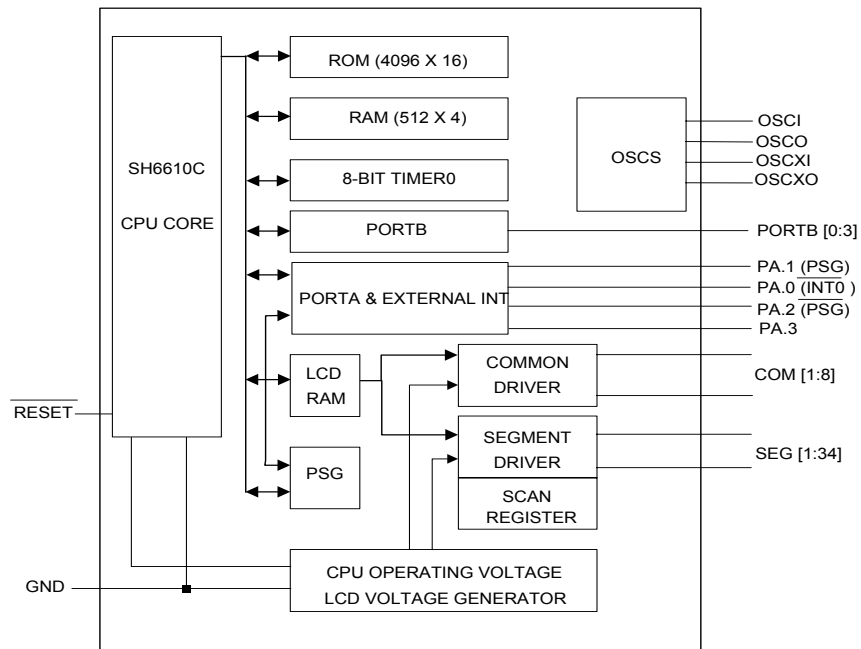



Pin Description (QFP64)

PIN No.	Designation	I/O	Description
3 - 8	SEG30 - SEG25	O	Segment signal output for LCD display; shared with scan output
12 - 35	SEG24 - SEG1	O	Segment signal output for LCD display; shared with scan output
36 - 39	V1 - V4	I	Connected with external LCD divided resistance
40	TEST	I	Test pin (Internal pull-low). No connect for user
44	RESET	I	Reset input (No internal pull-up)
45	VDD	P	Power supply
46 - 49	Port B.3 - Port B.0	I/O	Bit programmable I/O ,Vector interrupt ($\overline{INT1}$)
50 - 53	Port A.3 - Port A.0	I/O	Bit programmable I/O,PA.0 shared with $\overline{INT0}$ PA.1 , PA.2 shared with PSG output
54	OSCXI	I	Oscillator X input
55	OSCXO	O	Oscillator X output
56	GND	P	Ground
57	OSCO	O	Oscillator output
58	OSCI	I	Oscillator input
59 - 62	COM1 – COM4	O	Common signal output for LCD display
63 - 64, 1 - 2	COM5 - COM8	O	Common/segment signal output for LCD display

Pin Description (QFP100)

PIN No.	Designation	I/O	Description
1, 3, 5, 7, 9, 11, 13, 15, 17, 19, 21, 23, 25, 27, 29, 31, 33	SEG17 - SEG1	O	Segment signal output for LCD display; shared with scan output
83, 85, 87 - 94, 96, 98, 100	SEG30 - SEG18	O	Segment signal output for LCD display; shared with scan output
35, 37 - 39	V1 - V4	I	Connected with external LCD divided resistance
40	TEST	I	Test pin (Internal pull-low). No connect for user
41	RESET	I	Reset input (No internal pull-up)
42	VDD	P	Power supply
43, 44, 46, 48	Port B.3 - Port B.0	I/O	Bit programmable I/O ,Vector interrupt ($\overline{INT1}$)
50, 52, 54, 56	Port A.3 - Port A.0	I/O	Bit programmable I/O,PA.0 shared with $\overline{INT0}$ PA.1 , PA.2 shared with PSG output
58	OSCXI	I	Oscillator X input
60	OSCXO	O	Oscillator X output
62	GND	P	Ground
64	OSCO	O	Oscillator output
66	OSCI	I	Oscillator input
68, 70, 72, 74	COM1 - COM4	O	Common signal output for LCD display
76, 78, 80, 81	COM5 - COM8/SEG34 - SEG31	O	Common/segment signal output for LCD display

**Pad Description**

Pad No.	Designation	I/O	Description
1, 2, 31 - 58	SEG1 - SEG30	O	Segment signal output for LCD display; share with scan output
3 - 6	V1 - V4	I	Connected with external LCD divided resistance
7	TEST	I	Test pin (Internal pull-low). No connection for user
8	$\overline{\text{RESET}}$	I	Reset input (No internal pull-up)
9	VDD	P	Power supply
10 - 13	Port B.3 - Port B.0	I/O	Bit programmable I/O, Vector interrupt ($\overline{\text{INT1}}$)
14 - 17	Port A.3 - Port A.0	I/O	Bit programmable I/O, PA.0 shared with $\overline{\text{INT0}}$ PA.1, PA.2 shared with PSG output
18	OSCXI	I	Oscillator X input
19	OSCXO	O	Oscillator X output
20	GND	P	Ground
21	OSCO	O	Oscillator output
22	OSCI	I	Oscillator input
23 - 26	COM1 - COM4	O	Common signal output for LCD display
27 - 30	COM5 - COM8/SEG34 - SEG31	O	Common/segment signal output for LCD display



Functional Description

1. CPU

The CPU core contains the following function blocks: Program Counter, ALU, Carry Flag, Accumulator, Table Branch Register (TBR), Data Pointer (INX, DPH, DPM and DPL), and Stack.

1.1. PC (Program Counter)

The PC is used for ROM addressing consisting of 12-bits: Page Register (PC11), and Ripple Carry Counter (PC10 - PC0).

The program counter normally increases by one (+1) with each execution of an instruction except in the following cases:

- (1) When executing a jump instruction (such as JMP, BA0, BC),
- (2) When executing a subroutine call instruction (CALL),
- (3) When an interrupt occurs,
- (4) When the chip is at INITIAL RESET.

The program counter is loaded with data corresponding to each instruction. The unconditional jump instruction (JMP) can be set at 1-bit page register for higher than 2K. Program Counter can only address a 4K of program ROM.

1.2. ALU and CY

The ALU performs arithmetic and logic operations. It provides the following functions:
Binary addition/subtraction
(ADC, SBC, ADD, SUB, ADI, SBI)

Decimal adjustment for addition/subtraction (DAA, DAS),
Logic operations (AND, EOR, OR, ANDI, EORI, ORI)
Decision (BA0, BA1, BA2, BA3, BAZ, BC)
The Carry Flag (CY) holds the arithmetic operation ALU overflow.

During interrupt or call instruction, carry is pushed into stack and restored from stack by RTNI. It is unaffected by an RTNW instruction.

1.3. Accumulator

The accumulator is a 4-bit register holding the results of the arithmetic logic unit. In conjunction with the ALU, data transfers between the accumulator and system register, LCD RAM, or data memory can be performed.

1.4. Stack

This group of registers is used to save the contents of CY & PC (11 - 0) sequentially with each subroutine call or interrupt. It is organized 13 bits X 4 levels. The MSB is saved for CY. Four levels are the maximum allowed for subroutine calls and interrupts.

The contents of Stack are returned sequentially to the PC with the return instructions (RTNI/RTNW). Stack is operated on a first-in, last-out basis. This 4-level nesting includes both subroutine calls and interrupts requests. Note that program execution may enter an abnormal state if the number of calls and interrupt requests exceeds 4, where then the bottom of stack will be shifted out.

2. ROM

SH6614D can address 4096 × 16 bit of program area \$000 to \$FFF. There is an area from addresses \$000 through \$004 that is reserved for special interrupts service routines such as starting vector address.

Address	Instruction	Function
000H	JMP Instruction	Jump to RESET service routine
001H	JMP Instruction	Jump to INT0 service routine
002H	JMP Instruction	Jump to Timer0 service routine
003H	JMP Instruction	Jump to Base Timer service routine
004H	JMP Instruction	Jump to INT1 service routine



3. RAM

Built-in SRAM contains general-purpose data memory, LCD RAM, and system registers. They can be accessed by direct addressing in one instruction.

The following is the memory allocation map:

\$000 - \$01F: System register and I/O; \$020 - \$1FF: Data memory (480 X 4bits, partitioned into 4 banks).
 \$300 - \$321, \$328 - \$345, \$350 - \$36D: LCD RAM space (30 X 8 bits or 34 X 4 bits).

The configuration of system register

Address	Bit3	Bit2	Bit1	Bit0	Function	Initial Value	R/W
\$00	IEX	IET0	IEBT	IEP	Interrupt enable flags	0000	R/W
\$01	IRQX	IRQT0	IRQBT	IRQP	Interrupt request flags	0000	R/W
\$02	TM0.3	TM0.2	TM0.1	TM0.0	Timer0 mode register	0000	R/W
\$03	BTM.3	BTM.2	BTM.1	BTM.0	Base timer mode register	0000	R/W
\$04	T0L.3	T0L.2	T0L.1	T0L.0	Timer0 load/counter low nibble	0000	R/W
\$05	T0H.3	T0H.2	T0H.1	T0H.0	Timer0 load/counter high nibble	0000	R/W
\$06 - \$07	-	-	-	-	Reserved	-	-
\$08	PA.3	PA.2	PA.1	PA.0	PORTA	0000	R/W
\$09	PB.3	PB.2	PB.1	PB.0	PORTB	0000	R/W
\$0A	-	-	PC.1	PC.0	Bonding option	01 (default)	R
\$0B	PACR.3	PACR.2	PACR.1	PACR.0	Set PORTA to be output port	0000	W
\$0C	PBCR.3	PBCR.2	PBCR.1	PBCR.0	Set PORTB to be output port	0000	W
\$0D	-	-	-	-	Reserved	-	-
\$0E	TBR.3	TBR.2	TBR.1	TBR.0	Table branch register	0000	R/W
\$0F	INX.3	INX.2	INX1	INX.0	Index register (INX)	0000	R/W
\$10	DPL3	DPL2	DPL1	DPL0	Data pointer for INX low nibble	0000	R/W
\$11	-	DPM.2	DPM.1	DPM.0	Data pointer for INX middle nibble	0000	R/W
\$12	-	DPH.2	DPH.1	DPH.0	Data pointer for INX high nibble	0000	R/W
\$13	PPULL	PAM2	PAM1	HLM	Bit1, 2:PA.1 & PA.2 as PSG output or I/O PORT Bit0: Heavy load mode Bit3: Port pull-up control	0000	R/W
\$14	OXS	-	OXM	OXON	Bit0: Turn on OSCX oscillator Bit1: CPU clocks select (1:OSC X /0:OSC) Bit3: OSCX type selection	0000	R/W
\$15	LPS1	LPS0	LCDOFF	DUTY	Bit0: Slect LCD DUTY (1/8 or 1/4) Bit1: LCD off Bit2, 3:LCD frequency control	0000	R/W
\$16	LPD	O/S	-	-	Bit2: Set LCD segment as output Bit3: LCD Power degrade	0000	R/W
\$17	C1.3	C1.2	C1.1	C1.0	PSG channel 1 low nibble	0000	W
\$18	OCT1	C1.6	C1.5	C1.4	PSG channel 1high nibble Bit3: channel 1 octave shift control	0000	W
\$19	C2.3	C2.2	C2.1	C2.0	PSG channel 2 nibble 1 or alarm output	0000	W
\$1A	C2.7	C2.6	C2.5	C2.4	PSG channel 2 nibble 2	0000	W
\$1B	C2.11	C2.10	C2.9	C2.8	PSG channel 2 nibble 3	0000	W
\$1C	OCT2	C2.14	C2.13	C2.12	PSG channel 2 nibble 4 Bit3: channel 2 octave shift control	0000	W
\$1D	VOL1	VOL0	CH2EN	CH1EN	Bit0, Bit1: Channel 1, 2 enable Bit2, Bit3: volume control	0000	W
\$1E	SEL1	SEL0	C2M	C1M	Bit0, 1: PSG1, PSG2 mode control Bit2, 3: PSG1, PSG2 clock source selection	0000	W
\$1F	-	-	-	-	Reserved	-	-

System Register \$00 - \$12. (Please refer to SH6610C User's manual)



4. Data memory

The general purpose data memory is organized as 512 * 4 bits. Because of its static feature, the RAM can retain data after the CPU enters STOP or HALT mode.

5. Oscillator circuit

5.1. Circuit Configuration

SH6614D has two on-chip oscillation circuits OSC and OSCX.

OSC is a low frequency crystal (Typ. 32.768KHz) or RC (Typ.262KHz) determined by the code option. This is designed for low frequency operation. OSCX also has two types: ceramic (Typ.455KHz) or RC (1.8M or 2MHz) to be determined by the software option. It is designed for high frequency operation.

It is possible to select the high speed CPU processing by a high frequency clock and select low power operation by low operation clock. At the start of reset initialization, the OSC starts oscillation and OSCX is turned off. Immediately after reset initialization, the OSC clock is automatically selected as the system clock input source.

Oscillator Block Diagram

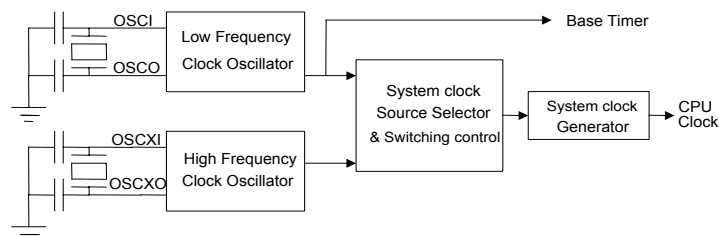

Timing of System Clock Switching

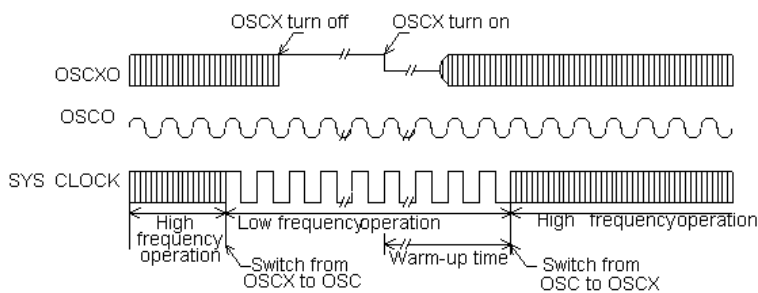



5.2. OSC oscillation

The OSC generates the basic clock pulses that provides the CPU and peripherals (Timer0, LCD) with an operating clock.

OSC Crystal oscillator type

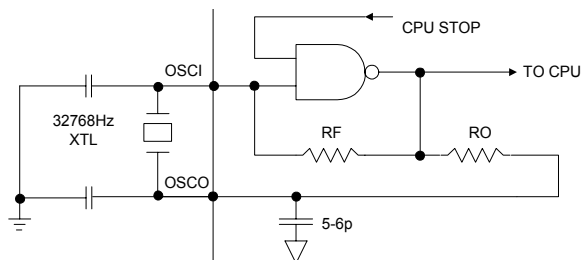

OSC RC oscillator type

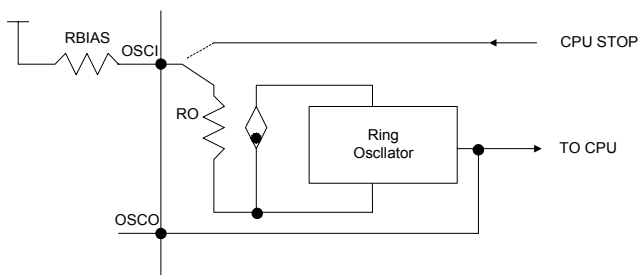

5.3. OSCX oscillation

OSCX has two clock oscillators. The software options selects the ceramic or RC as the CPU's subclock.

OSCX ceramic oscillator type

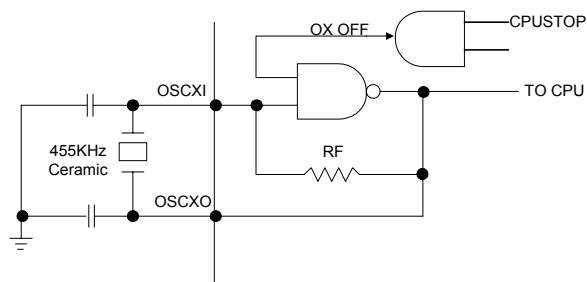

OSCX RC oscillator type

If the OSCX is not used, it must be masked as a ceramic resonator and the OSCXI must be connected to GND.

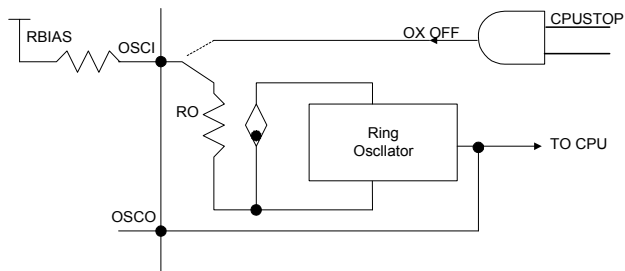



5.4. Control of oscillator

The oscillator control register configuration is shown as follows:

Address	Bit3	Bit2	Bit1	Bit0
\$14	OXS	-	OXM	OXON

OXON: OSCX oscillation on/off.

0: Turn-off OSCX oscillation

1: Turn-on OSCX oscillation

OXM: switching system clock.

0: select OSC as system clock

1: select OSCX as system clock

OXS: OSCX oscillator type selection

0: OSCX set as ceramic oscillator

1: OSCX set as RC oscillator

5.5. Programming notes

It takes at least 5 ms for the OSCX oscillation circuit to turn on until the oscillation stabilizes. When switching the CPU system clock from OSC to OSCX, the user must wait a minimum of 5ms since the OSCX oscillation is running. However, the start time varies with respect to oscillator characteristics and the condition of use. Thus the wait time depends on the application. When switching from OSCX to OSC, and turning off OSCX in one instruction. The OSCX turn off control will be delayed for one instruction cycle automatically to prevent CPU operation error.

6. System clock

The system clock varies as the clock source changes. The following table shows the instruction execution time according to each frequency of the system clock source.

	32.768 Xtal (OSC)	262K RC (OSC)	455K ceramic Xtal (OSCX)	1.8M RC (OSCX)	2M RC(OSCX)
Cycle time	122.07 μ s	17.778 μ s	8.79 μ s	2.22 μ s	2 μ s

7. I/O PORTS

The MCU provides 8bi-directional I/O pins. Each I/O pin contains pull-up MOS controllable through programming. When every I/O is used as input, the PORT control register (PACR, PBCR) controls the ON/OFF of the output buffer.

7.1. PORTA - B

These ports contain 8bi-directional I/O ports.

The circuit configuration of PORTA - B as is shown as:

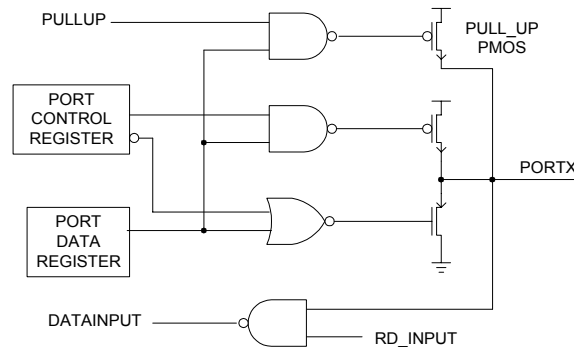

I/O ports of SH6614D can be accessed by the read/write system register.

User can output any value to any I/O port bit at any time.

Memory map addresses are listed as follows:

Address	Bit3	Bit2	Bit1	Bit0
\$08	PORTA.3	PORTA.2	PORTA.1	PORTA.0
\$09	PORTB.3	PORTB.2	PORTB.1	PORTB.0



7.2. Controlling the pull-up MOS

PORTA, PORTB contain pull-up MOS controlled by program. Bit3 of the PMOD register controls the on/off of all pull-up MOS simultaneously. Pull-up MOS are also controlled by the port data registers (PA, PB) of each port as well. Thus the pull-up MOS can be turned on/off.

7.3. Port Interrupt

PORTB interrupt (falling edge) is not controlled by the Port I/O register. This means that if a interrupt request (IEx is set to 1 & one port bit high goes low) has been touched therefore the condition is the other port bits are high level whenever the port bit is output or input.

7.4. External INT0

PortA.0 is shared by external interrupts (active low).

7.5. Port I/O control register:

Address	Bit3	Bit2	Bit1	Bit0
\$0B	PACR.3	PACR.2	PACR.1	PACR.0
\$0C	PBCR.3	PBCR.2	PBCR.1	PBCR.0

I/O control register: PACR.X, PBCR.X (X = 0, 1, 2, 3)

1: Use as an output buffer.

0: Use as an input buffer (initial power-on).

7.6. Port mode register (PMOD)

Address	Bit3	Bit2	Bit1	Bit0	Function	
\$13	PPULL	PAM2	PAM1	HLM	Bit1, 2: Select PA.1, PA.2 as I/O port or PSG output Bit0: Heavy load mode Bit3: Port pull-up control	R/W

PAM1, PAM2: Please see the PSG

HLM: Enable heavy load mode 0: Disable 1: Enable

PPULL: Port pull-up MOS 0: Disable pull-up MOS 1: Enable pull-up MOS

7.7. Heavy load mode (HLM)

The MCU has a heavy load protection circuit for when the battery load becomes heavy, such as, when an external buzzer sounds or an external speaker is turned on. In this mode, the crystal oscillator circuit has backup for high gain. When setup this mode, more power would be provided to an oscillator circuit. Unless it is necessary, be careful not to set this mode with the software since the mode enter would delay for one instruction. Please activate heavy load driving only after setting HLM at least one instruction wait cycle through the software. The following shows the programming setting.

HLM: 0 = Heavy load protection mode is released

1 = Heavy load protection mode is set.

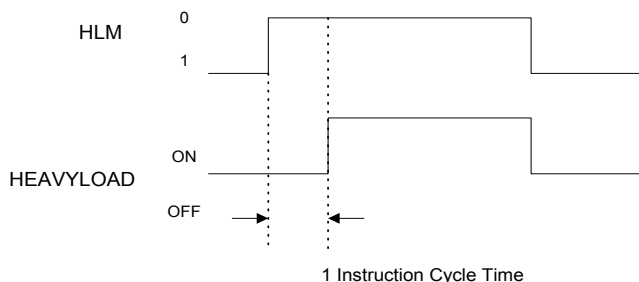



8. Programmable sound generator (PSG)

PSG has channel1 and channel2. The function block diagram is shown as follows:

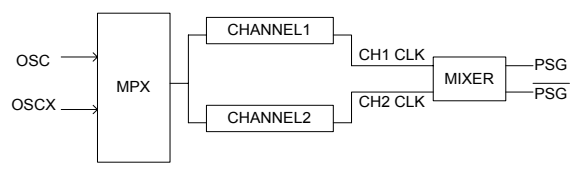

The PSG function provides four subfunctions for wide applications.

Programmable sound

Program sound is created by two channels. Every channel can be programmed as follows:

- Enable/Disable every channel sounds.
- Select every channel sound frequency.
- Two channel sounds are mixed into one PSG output.
- The PSG output can be controlled at 4 volume levels.

Fine noise

PSG can provide wide-band noise.
The wide-band noise volume can be controlled at 4 volume levels.

Alarm

PSG can provide many alarm functions by the software.
The alarm carrier frequency can be programmed individually.
The alarm volume can be controlled at 4 volume levels.

Remote control

The remote control is the only expandable application for PSG sound. Since the remote control frequency is 56.13KHz or 37.92KHz, the software can select the sound frequency.

8.1. PSG subblock diagram

MPX block diagram

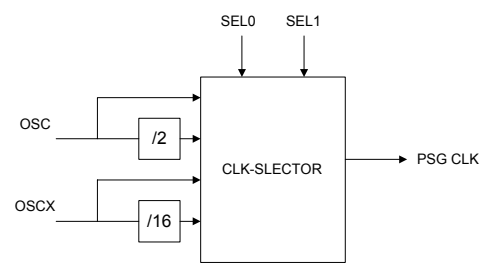

SEL1	SEL0	Clk source	OSC clk	PSG clk
0	0	OSC	OSC = 32.768K	32.768K
			OSC = 262K	262K
0	1	OSC/2	OSC = 32.768K	16.384K
			OSC = 262K	131K
1	0	OSCX	OSCX = 1.8M	1.8M
			OSCX = 455K	455K
1	1	OSCX/16	OSCX = 1.8M	112.5K
			OSCX = 455K	28.4K

The MPX block selects 4 clock sources as PSG clk that provides the two channel clk sources.



Channel 1

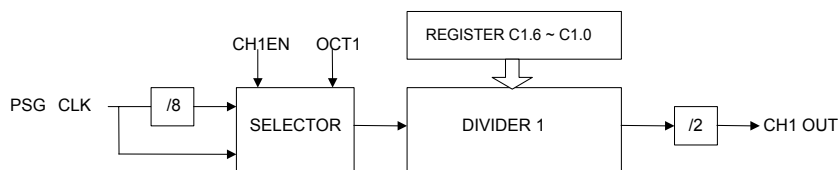

OCT1	Scaling ratio
0	1
1	1/8

Channel 1 is constructed by a 7-bit pseudo random counter. Channel 1 is enabled/disabled by CH1EN. It creates either a sound frequency or an alarm carrier frequency or a remote carrier frequency.

Channel 2

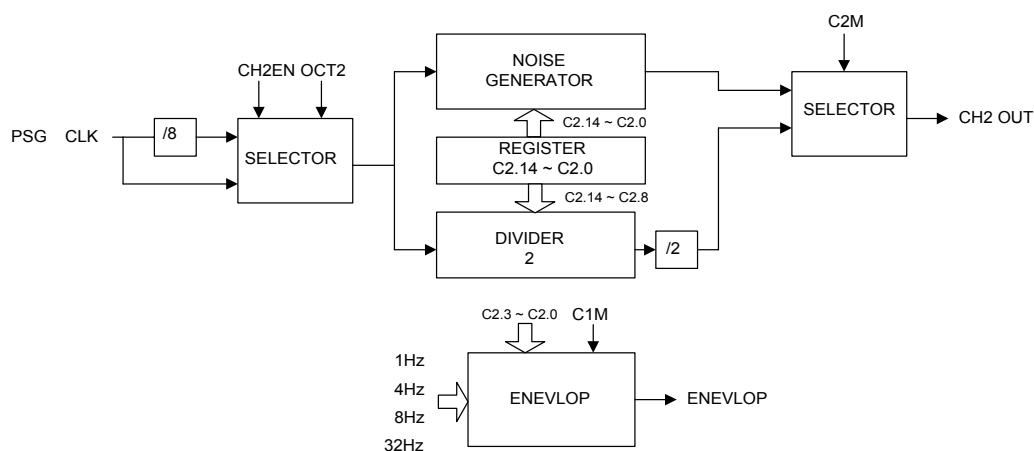

OCT2	Scaling ratio
0	1
1	1/8

Channel 2 is constructed by a 15-bit pseudo random counter. Channel 2 is enabled/disabled by CH2EN. It can be a 15-bit wide-band noise generator or a 7-bit sound generator. It can also create an alarm envelope signal.

C2M	C1M	Function
0	0	CH1 is a Sound generator. CH2 is a Sound generator.
1	0	CH1 is a Sound generator. CH2 is a Noise generator.
x	1	CH1 is a Sound generator. CH2 is an Alarm mode register.



Mixer

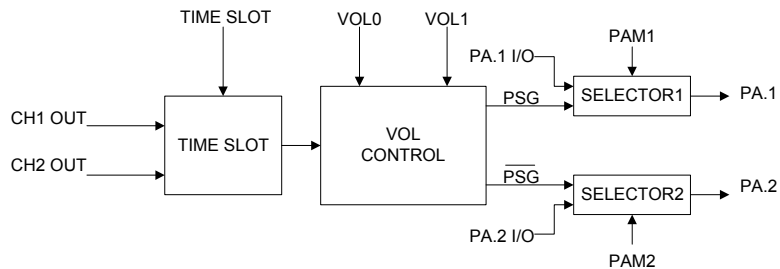

The MIXER mixes CH1-OUT and CH2-OUT into one tone output to PA.1 · PA.2, when PAM1 = 1 · PAM2 = 1. Then the tone output is controlled by the volume control bit into 4 volume levels and in the end outputted by PSG.

PA.1 & PA.2 are controlled by PAM1 & PAM2

PAM2	PAM1	Function
0	0	PA.1:I/O PORT PA.2: I/O PORT
0	1	PA.1:PSG output PA.2: I/O PORT
1	0	PA.1:I/O PORT PA.2: $\overline{\text{PSG}}$ output
1	1	PA.1:PSG output PA.2: $\overline{\text{PSG}}$ output

SEL1	SEL0	Vol. control
0	0	NO
0	1	YES
1	0	YES
1	1	YES

VOL1	VOL0	Vol. Level
0	0	1
0	1	2
1	0	3
1	1	4

Note: The user should not enable two PSG channels together to produce one tone, otherwise it will produce some unpredictable errors. If it is necessary to use 2 channels together (ie: to play two channel melody), do not allow score always be the same tones, then the unpredicted errors will not occur or it will be ignored by user.



SH6614D

The value N of divider1 is corresponding to the REG C1.6 ~ C1.0 or REG C2.14 ~ C2.8 as shown in the following table:

I SFR (C1.6 ~ C1.0) (C2.14 ~ C2.8)	N	I SFR (C1.6 ~ C1.0) (C2.14 ~ C2.8)	N	I SFR (C1.6 ~ C1.0) (C2.14 ~ C2.8)	N	I SFR (C1.6 ~ C1.0) (C2.14 ~ C2.8)	N
01	127	16	95	12	63	4B	31
02	126	2C	94	24	62	17	30
04	125	59	93	49	61	2E	29
08	124	33	92	13	60	5D	28
10	123	67	91	26	59	3B	27
20	122	4E	90	4D	58	77	26
41	121	1D	89	1B	57	6E	25
03	120	3A	88	36	56	5C	24
06	119	75	87	6D	55	39	23
0C	118	6A	86	5A	54	73	22
18	117	54	85	35	53	66	21
30	116	29	84	6B	52	4C	20
61	115	53	83	56	51	19	19
42	114	27	82	2D	50	32	18
05	113	4F	81	5B	49	65	17
0A	112	1F	80	37	48	4A	16
14	111	3E	79	6F	47	15	15
28	110	7D	78	5E	46	2A	14
51	109	7A	77	3D	45	55	13
23	108	74	76	7B	44	2B	12
47	107	68	75	76	43	57	11
0F	106	50	74	6C	42	2F	10
1E	105	21	73	58	41	5F	9
3C	104	43	72	31	40	3F	8
19	103	07	71	63	39	7F	7
72	102	0E	70	46	38	7E	6
64	101	1C	69	0D	37	7C	5
48	100	38	68	1A	36	78	4
11	99	71	67	34	35	70	3
22	98	62	66	69	34	60	2
45	97	44	65	52	33	40	1
0B	96	09	64	25	32		



8.2. Function description

PSG as sound generator

The programmable sound is one of the 4 working modes. The software designer can select up to 16 clock sources as PSG clk. And then select the CH1 and CH2 frequency divided value that is controlled by the value of REG C1.6 ~ C1.0 or C2.14 ~ C2.8. The user can select the 4 volume level controlled by VOL0, VOL1. The music tone can output both PSG and $\overline{\text{PSG}}$. The user also can control the OCT1, OCT2 bit that shifts the music tone 3 octaves.

Example 1: CH1EN = CH2EN = 1
 OSCX = 1.8M, SEL0 = SEL1 = 1
 So PSG clk = 112kHz; Switch clk = 28kHz
 Vol. Clk = 112kHz

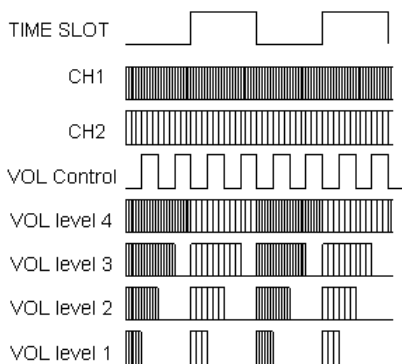

Example 2: CH1EN = 0; CH2EN = 1
 OSCX = 1.8M, SEL0 = SEL1 = 1
 So PSG clk = 112kHz; Switch clk = 28kHz;
 Vol. Clk = 112kHz

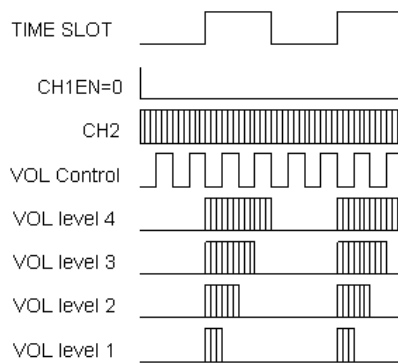

Example 3: CH1EN = CH2EN = 1
 OSC = 32k, SEL0 = SEL1 = 0
 So PSG clk = 32kHz; Switch clk = 32kHz
 No vol. control, the VOL level is set to 4 by hardware, so software should set VOL0 = VOL1 = 1.

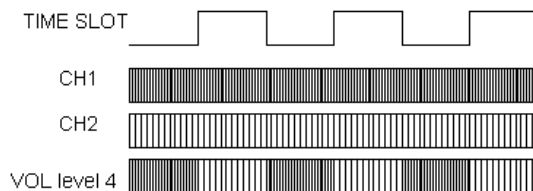

Note: For 32KHz operations, the volume control cannot be used, since the PWM multiplexing frequency is not high enough to switch sound! If a user wants to turn off the PSG completely, the software must disable both channels. The user should not turn off the PSG by zero wave from output. Both the CH1EN and CH2EN should be set to "0" for the low power operation mode.

Example 4

If software designer wants to create C2 (Channel 1) mixed with F5 (Channel 2) sound (For the C2, F5 sound frequency please refer to Music Table 1 and Music Table 2), VOL level = 3. Then the user can select the suggestion as follows:

- (1) The user first selects CH1EN = CH2EN = 1, C1M = C2M = 0.
- (2) The user can select OSCX = 1.8M and SEL0 = SEL1 = 1, so the PSG CLK = 112.5KHz.
- (3) Then The user can select OCT1 = 1 and the value of channel 1 LSFR (C1.6 ~ C1.0) = 23, so the N = 108. Please see the Music Table 1. So the channel 1 sound frequency = $112.5\text{KHz}/8 / (2 \times 108) = 64.10\text{Hz} \approx$ the C2 sound frequency.
- (4) Then The user can select OCT1 = 0 and the value of channel 1 LSFR (C1.6 ~ C1.0) = 4F, so the N = 81. Please refer to the Music Table 1. So the channel 1 sound frequency = $112.5\text{KHz}/1 / (2 \times 81) = 694.4\text{Hz} \approx$ the F5 sound frequency .
- (5) Lastly, the user should select the VOL1 = 1 and VOL0 = 0, so the VOL level = 3.



Note:

The designer provides two crossing tables as an appendix since the designer prefers PSG clk = 32.768K or PSG clk = 112.5K.

PSG as a noise generator

Fine noise is created by CH2. If the user wants to create the single noise, then make the CH1 music tone output. Otherwise, the user can mix the wide-band noise and the CH1 music tone into one output through the MIXER. Lastly, the user can select 4 volume levels controlled by VOL0, VOL1.

PSG as an alarm generator

When PSG is in the alarm mode, the CH1 provides the alarm carrier frequency and the CH2 provides the alarm envelope signal. Lastly the user can select 4 volume levels controlled by VOL0, VOL1. The channel 2 low nibble C2.0 ~ C2.3 will be the alarm control register. Channel 1 output would modulate with an ALARM envelope control for 32KHz or 262KHz. The carrier frequency can be programmed by PSG channel 1. In reading this alarm control register, the user can read the corresponding output envelope frequency (the 1Hz, 4Hz, 8Hz, 32Hz).

Alarm control register (OSC = 32KHz or 262KHz)

\$19	C2.3	C2.2	C2.1	C2.0	Alarm output control
	0	0	0	0	DC envelop
	X	X	X	1	1Hz output
	X	X	1	X	4Hz output
	X	1	X	X	8Hz output
	1	X	X	X	32Hz output

Figure: Alarm modulation output for OSC = 32.768KHz or OSC = 262KHz.

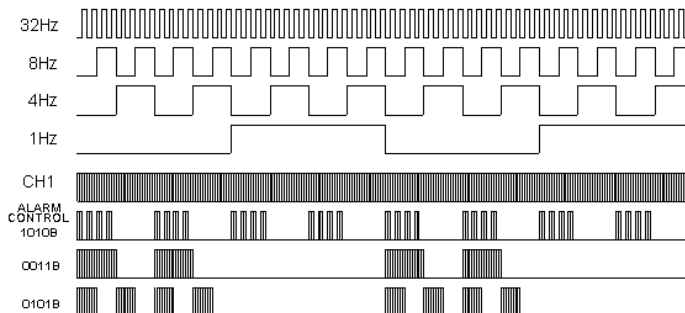

PSG as remote control

The remote control is only an expandable application for PSG sound. The user can select the CH1 as tone output and the CH2 will create alarm frequency envelope signal.

When PSG channel is programmed in the ALARM mode, the programmer can set ALARM mode register to "0000B". Program the adequate frequency output to PSG output. Then use PAM1 or PAM2 control the envelope of code. In this way, remote control function can be implemented easily.

The remote frequency = 56.73KHz or 37.92KHz.

The software should select OSCX = 455KHz, SEL = 1 and SEL0 = 0, so that the PSG CLK = 455KHz. Then select channel 1 alarm mode (C1M = 1), and OCT1 = 0, C2.0 ~ C2.3 are set to 00H. VOL1, VOL2 = 1, 1. Then select C1.6 ~ C1.0 = 7E, so that N = 6 and the PSG output frequency = 455KHz/1/ (2 X 6) = 37.92KHz. Or select C1.6 ~ C1.0 = 78, so that N = 4 and the PSG output frequency = 455KHz/1/ (2 X 4) = 56.87KHz.

**9. Timer 0**

SH6614D has one 8-bit timer. The timer consists of an 8-bit up counter and an 8-bit preload register.

The timers provide the following functions:

- Programmable internal timer function
- Read the counter values

9.1. Timer 0 configuration and operation

The timer 0 consists of an 8-bit write-only timer load register (TL0L, TL0H) and an 8-bit read-only timer counter (TC0L, TC0H). Each has low order digits and high order digits. The timer counter can be initialized by writing data into the timer load register (TL0L, TL0H). Write the low-order digit first and then the high-order digit. The timer counter is loaded with the content of the load register automatically when the high order digit is written or counts overflow happens. The timer overflow will generate an interrupt, if the interrupt enable flag is set.

The timer can be programmed in several different system clock sources by setting the Timer Mode register (TM0).

Timer 0 reads and writes operations follow these rules:

Write Operation	Read Operation
Low nibble first	High nibble first
High nibble to update the counter	Low nibble follows

9.2. Timer0 mode register (TM0)

The 8-bit counter counts prescaler overflow output pulses. TM0 are 4-bit registers used for timer control as shown in Table 1. The register selects the input clock sources in the timer.

Table 1. Timer0 Mode registers (\$02)

TM0.3	TM0.2	TM0.1	TM0.0	Prescaler	Clock Source
0	0	0	0	/2048	System clock
0	0	0	1	/512	System clock
0	0	1	0	/128	System clock
0	0	1	1	/32	System clock
0	1	0	0	/8	System clock
0	1	0	1	/4	System clock
0	1	1	0	/2	System clock
0	1	1	1	External	$\overline{\text{INT0}}$

TM0.3 control function:

0: without Auto-Reload function

1: Auto-Reload function

9.3. Warm-up counter

In RC mode, the warm-up counter prescaler is divided by 2^7 (128).

In CRYSTAL mode, the warm-up counter prescaler is divided by 2^{15} (65536).



10. Base Timer

The MCU has a base timer that is shared with the warm-up timer and the clock source is OSC (Low frequency oscillation: X'Tal 32.768KHz or RC 262KHz). After MCU is reset, it counts at every clock-input signal. When it counts to \$FF, right after next clock input, counter counts to \$00 and generates an overflow. This causes the interrupt of base timer interrupt request flag to 1. Therefore, the base timer can function as an interval timer periodically, generating overflow output as every 256th clock signal output.

The timer accepts 4096Hz or 32KHz clock, and base timer generates an accurate timing interrupt. This base time prescaler can be reset by the program for accurate timing.

This clock-input source is selected by BTM register.

Address	Bit3	Bit2	Bit1	Bit0	Function
\$03	BTM.3	BTM.2	BTM.1	BTM.0	Base timer mode register

BTM.3 = 0: Disable the base timer

BTM.3 = 1: Enable the base timer

BTM.2 = 0: Non reset the base timer

BTM.2 = 1: reset the base timer

BTM.1	BTM.0	Prescaler Ratio	Clock source
0	0	/1	4096Hz or 32KHz
0	1	/4	4096Hz or 32KHz
1	0	/8	4096Hz or 32KHz
1	1	/16	4096Hz or 32KHz

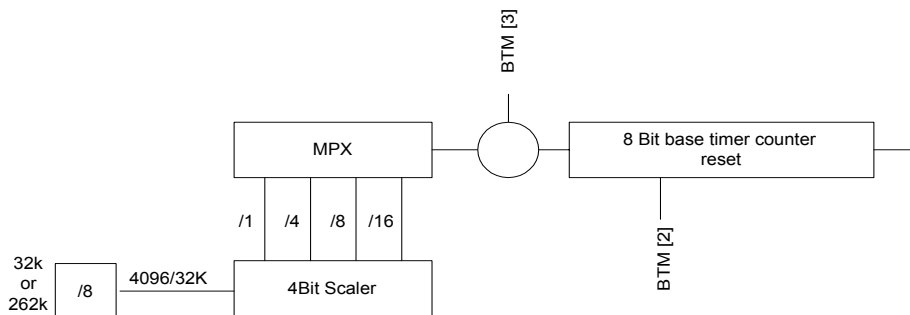



11. LCD Driver

The LCD driver contains a controller, a voltage generator, 8 common signal pins and 30 segment driver pins. There are two different driving modes programmable: one is 1/8 duty and 1/4 bias, the other is 1/4 duty and 1/3 bias. The driving mode is controlled by the system register \$15 and the power-on initialization status is 1/8 duty, 1/4 bias. When 1/4 duty and 1/3 bias mode are used, COM5 - 8 is used as SEG34 - 31.

The LCD SEG1 - 30 can also be used as output port, it is selected by the bit 2 of the system register \$16. When SEG1 - 30 is to be an output port, data must be written to bit 0 of the same addresses (350H-36DH). LCD RAM could be used as data memory if needed. When the "STOP" instruction is executed, the LCD will be turned off, but the data of LCD RAM keeps the same value before executing the "STOP" instruction.

11.1. LCD Control Register

Addr.	Bit 3	Bit 2	Bit 1	Bit 0
\$15	LPS1	LPS0	LCDOFF	DUTY

LCDOFF: LCD on/off switch.

0: LCD on.

1: LCD off.

DUTY: LCD duty control

0: 1/8 duty, 1/4 bias

1: 1/4 duty, 1/3 bias

LPS1, LPS0: LCD clock frequency control

0,0: LCDCLK = OSC/64

0,1: LCDCLK = OSC/512

1,0: LCDCLK = System clock/512

1,1: LCDCLK = System clock/4096

*System clock = Instruction cycle time

Frame frequency = LCDCLK/16

Frame frequency for 1/8 duty; 1/4 duty has the same frequency cycle.

CLK Frequency	LPS1, LPS0			
	0, 0	0, 1	1, 0	1, 1
OSC = 32kHz (#) , OSCX = 455kHz	32Hz	4Hz	1Hz	1/8Hz
OSC = 32kHz, OSCX = 455kHz (#)	32Hz	4Hz	14Hz	1.7Hz
OSC = 32kHz (#) , OSCX = 1.8MHz	32Hz	4Hz	1Hz	1/8Hz
OSC = 32kHz, OSCX = 1.8MHz (#)	32Hz	4Hz	55Hz	6.9Hz
OSC = 32kHz (#) , OSCX = 2MHz	32Hz	4Hz	1Hz	1/8Hz
OSC = 32kHz, OSCX = 2MHz (#)	32Hz	4Hz	61Hz	7.6Hz
OSC = 262kHz (#) , OSCX = 455kHz	256Hz	32Hz	8Hz	1Hz
OSC = 262kHz, OSCX = 455kHz (#)	256Hz	32Hz	14Hz	1.7Hz
OSC = 262kHz (#) , OSCX = 1.8MHz	256Hz	32Hz	8Hz	1Hz
OSC = 262kHz, OSCX = 1.8MHz (#)	256Hz	32Hz	55Hz	6.9Hz
OSC = 262kHz (#) , OSCX = 2MHz	256Hz	32Hz	8Hz	1Hz
OSC = 262kHz, OSCX = 2MHz (#)	256Hz	32Hz	61Hz	7.6Hz

The clk before (#) is selected as CPU system clk.

Frame frequency = LCDCLK/16 (32Hz)

When the LCD is set to SCAN OUT, COMx are pulled high. It is easy to implement the keyboard scan.

When the CPU is in STOP mode, the COMx and SEGx are pulled low. It can easily be woken up by a keyboard scan (Port interrupt). When the CPU is in HALT mode, the COMx and SEGx are normal. It can easily be woken up by base timer, timer0 or port interrupt.



11.2. LCD power

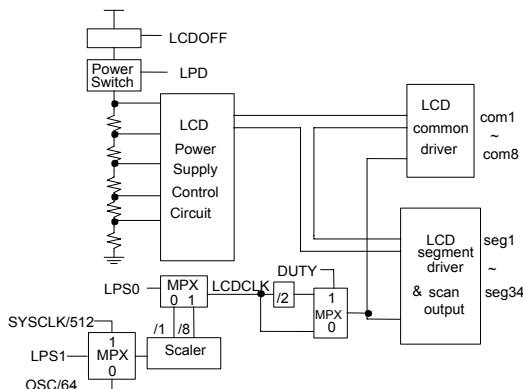

Built-in special LCD power control for LCD power modulation.

Address	Bit 3	Bit 2	Bit 1	Bit 0
\$16	LPD	O/S	-	-

O/S: Set LCD segment/common to be LCD segment output or output ports

0: LCD segment output 1: output ports.

When LPD is set to 1, the LCD voltage power will be degraded to about 0.5V, depending on the VDD level. It is designed to reduce extra LCD contrast control output pins. Then the LCD can be fitted automatically for different voltage levels by the software.

11.3. Configuration of LCD RAM

LCD 1/4 duty, 1/3 bias (COM1 - 4, SEG1 - 34)

Address	Bit3	Bit2	Bit1	Bit0	Address	Bit3	Bit2	Bit1	Bit0
	COM4	COM3	COM2	COM1		COM4	COM3	COM2	COM1
300H	SEG1	SEG1	SEG1	SEG1	311H	SEG18	SEG18	SEG18	SEG18
301H	SEG2	SEG2	SEG2	SEG2	312H	SEG19	SEG19	SEG19	SEG19
302H	SEG3	SEG3	SEG3	SEG3	313H	SEG20	SEG20	SEG20	SEG20
303H	SEG4	SEG4	SEG4	SEG4	314H	SEG21	SEG21	SEG21	SEG21
304H	SEG5	SEG5	SEG5	SEG5	315H	SEG22	SEG22	SEG22	SEG22
305H	SEG6	SEG6	SEG6	SEG6	316H	SEG23	SEG23	SEG23	SEG23
306H	SEG7	SEG7	SEG7	SEG7	317H	SEG24	SEG24	SEG24	SEG24
307H	SEG8	SEG8	SEG8	SEG8	318H	SEG25	SEG25	SEG25	SEG25
308H	SEG9	SEG9	SEG9	SEG9	319H	SEG26	SEG26	SEG26	SEG26
309H	SEG10	SEG10	SEG10	SEG10	31AH	SEG27	SEG27	SEG27	SEG27
30AH	SEG11	SEG11	SEG11	SEG11	31BH	SEG28	SEG28	SEG28	SEG28
30BH	SEG12	SEG12	SEG12	SEG12	31CH	SEG29	SEG29	SEG29	SEG29
30CH	SEG13	SEG13	SEG13	SEG13	31DH	SEG30	SEG30	SEG30	SEG30
30DH	SEG14	SEG14	SEG14	SEG14	31EH	SEG31	SEG31	SEG31	SEG31
30EH	SEG15	SEG15	SEG15	SEG15	31FH	SEG32	SEG32	SEG32	SEG32
30FH	SEG16	SEG16	SEG16	SEG16	320H	SEG33	SEG33	SEG33	SEG33
310H	SEG17	SEG17	SEG17	SEG17	321H	SEG34	SEG34	SEG34	SEG34



LCD 1/8 duty, 1/4 bias (COM1 - 8, SEG1 - 30)

Address	Bit3	Bit2	Bit1	Bit0	Address	Bit3	Bit2	Bit1	Bit0
	COM4	COM3	COM2	COM1		COM8	COM7	COM6	COM5
300H	SEG1	SEG1	SEG1	SEG1	328H	SEG1	SEG1	SEG1	SEG1
301H	SEG2	SEG2	SEG2	SEG2	329H	SEG2	SEG2	SEG2	SEG2
302H	SEG3	SEG3	SEG3	SEG3	32AH	SEG3	SEG3	SEG3	SEG3
303H	SEG4	SEG4	SEG4	SEG4	32BH	SEG4	SEG4	SEG4	SEG4
304H	SEG5	SEG5	SEG5	SEG5	32CH	SEG5	SEG5	SEG5	SEG5
305H	SEG6	SEG6	SEG6	SEG6	32DH	SEG6	SEG6	SEG6	SEG6
306H	SEG7	SEG7	SEG7	SEG7	32EH	SEG7	SEG7	SEG7	SEG7
307H	SEG8	SEG8	SEG8	SEG8	32FH	SEG8	SEG8	SEG8	SEG8
308H	SEG9	SEG9	SEG9	SEG9	330H	SEG9	SEG9	SEG9	SEG9
309H	SEG10	SEG10	SEG10	SEG10	331H	SEG10	SEG10	SEG10	SEG10
30AH	SEG11	SEG11	SEG11	SEG11	332H	SEG11	SEG11	SEG11	SEG11
30BH	SEG12	SEG12	SEG12	SEG12	333H	SEG12	SEG12	SEG12	SEG12
30CH	SEG13	SEG13	SEG13	SEG13	334H	SEG13	SEG13	SEG13	SEG13
30DH	SEG14	SEG14	SEG14	SEG14	335H	SEG14	SEG14	SEG14	SEG14
30EH	SEG15	SEG15	SEG15	SEG15	336H	SEG15	SEG15	SEG15	SEG15
30FH	SEG16	SEG16	SEG16	SEG16	337H	SEG16	SEG16	SEG16	SEG16
310H	SEG17	SEG17	SEG17	SEG17	338H	SEG17	SEG17	SEG17	SEG17
311H	SEG18	SEG18	SEG18	SEG18	339H	SEG18	SEG18	SEG18	SEG18
312H	SEG19	SEG19	SEG19	SEG19	33AH	SEG19	SEG19	SEG19	SEG19
313H	SEG20	SEG20	SEG20	SEG20	33BH	SEG20	SEG20	SEG20	SEG20
314H	SEG21	SEG21	SEG21	SEG21	33CH	SEG21	SEG21	SEG21	SEG21
315H	SEG22	SEG22	SEG22	SEG22	33DH	SEG22	SEG22	SEG22	SEG22
316H	SEG23	SEG23	SEG23	SEG23	33EH	SEG23	SEG23	SEG23	SEG23
317H	SEG24	SEG24	SEG24	SEG24	33FH	SEG24	SEG24	SEG24	SEG24
318H	SEG25	SEG25	SEG25	SEG25	340H	SEG25	SEG25	SEG25	SEG25
319H	SEG26	SEG26	SEG26	SEG26	341H	SEG26	SEG26	SEG26	SEG26
31AH	SEG27	SEG27	SEG27	SEG27	342H	SEG27	SEG27	SEG27	SEG27
31BH	SEG28	SEG28	SEG28	SEG28	343H	SEG28	SEG28	SEG28	SEG28
31CH	SEG29	SEG29	SEG29	SEG29	344H	SEG29	SEG29	SEG29	SEG29
31DH	SEG30	SEG30	SEG30	SEG30	345H	SEG30	SEG30	SEG30	SEG30

SEG1-30 is used as scan output port.

Address	Bit0	Address	Bit0	Address	Bit0	Address	Bit0
350H	SEG1	358H	SEG9	360H	SEG17	368H	SEG25
351H	SEG2	359H	SEG10	361H	SEG18	369H	SEG26
352H	SEG3	35AH	SEG11	362H	SEG19	36AH	SEG27
353H	SEG4	35BH	SEG12	363H	SEG20	36BH	SEG28
354H	SEG5	35CH	SEG13	364H	SEG21	36CH	SEG29
355H	SEG6	35DH	SEG14	365H	SEG22	36DH	SEG30
356H	SEG7	35EH	SEG15	366H	SEG23		
357H	SEG8	35FH	SEG16	367H	SEG24		



11.4. LCD waveform

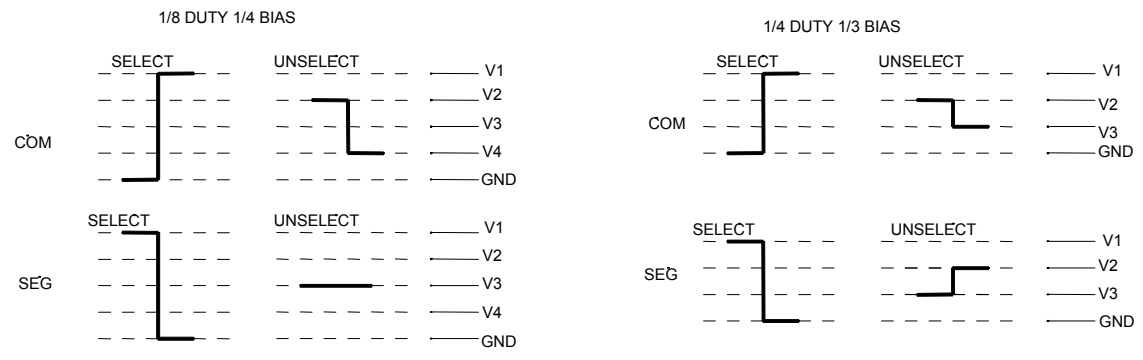

Example 1/8 Duty 1/4 Bias

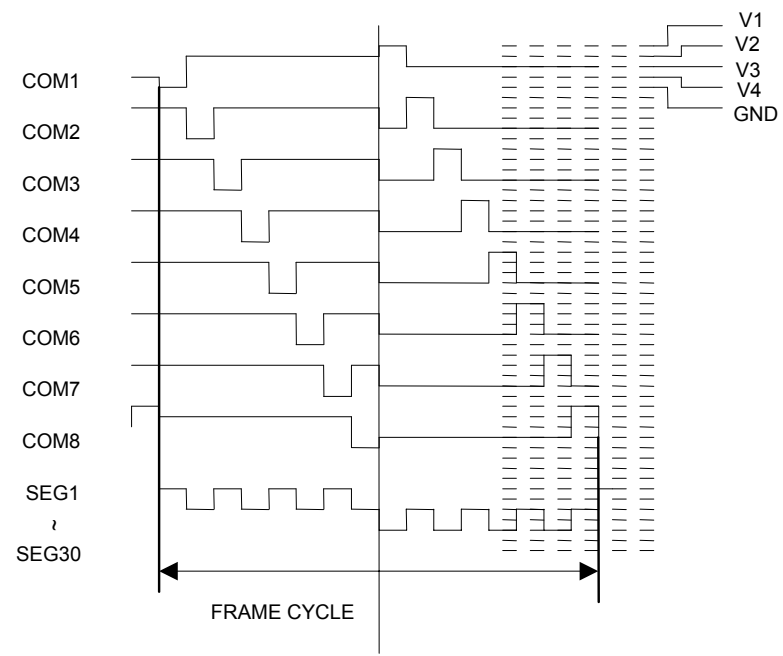

This example SEG1 - SEG30 for COM1, COM3, COM5, COM7 are lighting.
 SEG1 - SEG30 for COM2, COM4, COM6, COM8 are not lighting.



12. Interrupt

4 interrupt sources are available on SH6614D:

- External interrupt ($\overline{INT0}$)
- Timer0 interrupt
- Base timer interrupt
- Port's falling edge detection interrupt ($\overline{INT1}$)

The configuration of system register \$0:

Address	Bit 3	Bit 2	Bit 1	Bit 0	Function
\$00	IEX	IET0	IEBT	IEP	1: Enable / 0: Disable
\$01	IRQX	IRQT0	IRQBT	IRQP	1: Request / 0: No request

12.1. External Interrupt ($\overline{INT0}$)

External interrupt is shared with the PA.0, falling edge active. When the bit 3 of the register \$0 (IEX) is set to 1, the external interrupt is enabled, writing a "0" to PA.0 will generate an external interrupt.

12.2. Timer 0 interrupt, Base timer interrupt, Port interrupt ($\overline{INT1}$)

If lex = 1 then all valid interrupt requests will cause an interrupt. The overflow of timer 0 will create the interrupt of timer 0. The overflow of the Base timer will create the interrupt of the Base timer. The falling edge of every port in PORTB will create $\overline{INT1}$ interrupt (The condition is that the other port must be input/output high level).

12.3. The Enable flags and Request flags

Both the Enable flags and Request flags can be read or written by the software. But the Request flags will be set "1" by the hardware interrupt and the Enable flags will be reset by the hardware when the interrupt service routine is entered.

12.4. Interrupt Servicing Sequence Diagram:

In SH6610C CPU interrupt services routine, the user can enable any interrupt enable flag before returning from an interrupt. The frequently asked question is when the next interrupt would be serviced? Will the nesting interrupt happen? From the servicing sequence timing diagram, if interrupt request is ready and instruction execution N is IE enable. Then the interrupt can start right after the next two instructions: I1 or instruction I2 disable the interrupt request or enable flag, then interrupt service sequence would be terminated.

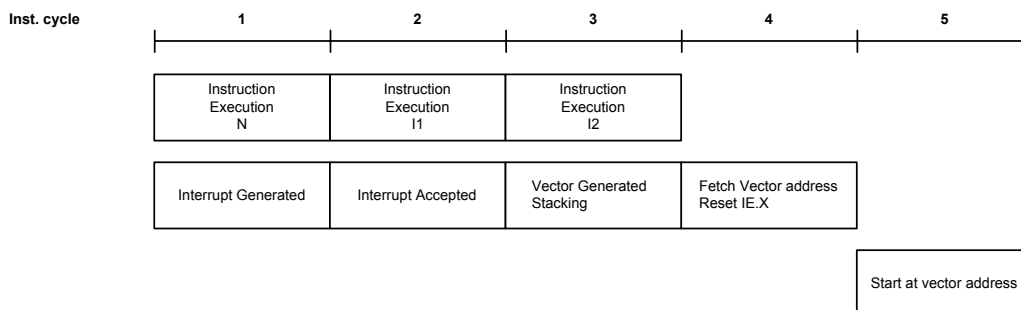



13. Options

Bonding options

System register \$0A is reserved for the user. It is available for system developer to select 2 bonding options, and selecting a subprogram is programmed by the user.

\$0A.1 (PC.1)	\$0A.0 (PC.0)	
0	0	goto subroutine 1
0	1	goto subroutine 2 (Default)
1	0	goto subroutine 3
1	1	goto subroutine 4

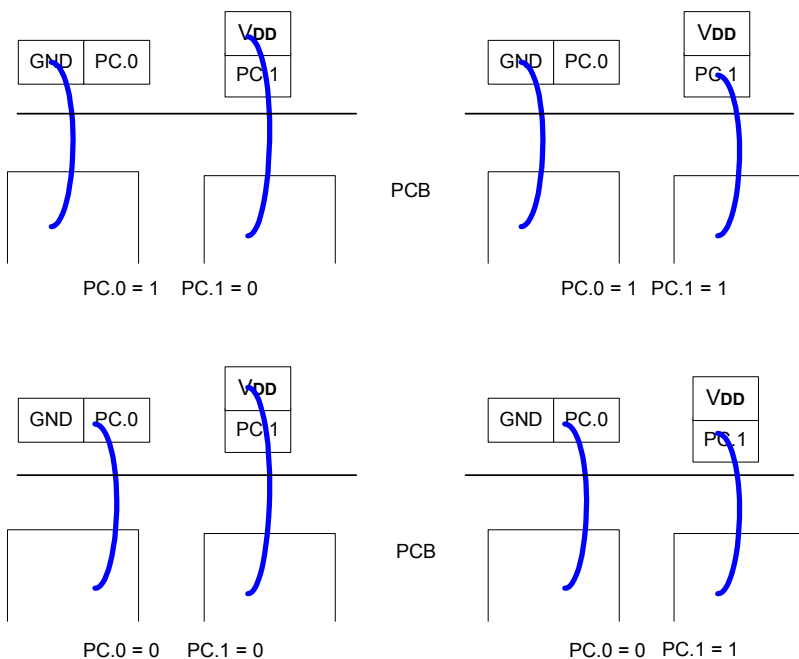

SH6614D Bonding Option

14. STOP/HALT mode

STOP/HALT mode	Oscillator	CPU core	Wake up	Executing after wake up
STOP (STOP instruction)	OSC OSCX Stop	Hold	\overline{RST} , $\overline{INT0}$, $\overline{INT1}$	(a) If \overline{RST} signal valid, system will reset. (b) If $\overline{INT0}$, $\overline{INT1}$ signal valid, system will enter interrupt subroutine, then execute the main program to continue.
HALT (HALT instruction)	OSC OSCX live	Hold	\overline{RST} , $\overline{INT0}$, $\overline{INT1}$, T0INT BTINT	(a) If \overline{RST} signal valid, system will reset. (b) If $\overline{INT0}$, $\overline{INT1}$, T0INT or BTINT signal valid, system will enter interrupt subroutine first, then execute the main program to continue.



15. Instruction set

All instructions are one cycle and one word instructions. The characteristic is memory-oriented operation.
Arithmetic and Logical Instruction

Accumulator type

Mnemonic	Instruction Code	Function	Flag Change
ADC X (, B)	00000 0bbb xxx xxxx	AC \leftarrow Mx + Ac + CY	CY
ADCM X (, B)	00000 1bbb xxx xxxx	AC, Mx \leftarrow Mx + Ac + CY	CY
ADD X (, B)	00001 0bbb xxx xxxx	AC \leftarrow Mx + Ac	CY
ADDM X (, B)	00001 1bbb xxx xxxx	AC, Mx \leftarrow Mx + Ac	CY
SBC X (, B)	00010 0bbb xxx xxxx	AC \leftarrow Mx + -Ac + CY	CY
SBCM X (, B)	00010 1bbb xxx xxxx	AC, Mx \leftarrow Mx + -Ac + CY	CY
SUB X (, B)	00011 0bbb xxx xxxx	AC \leftarrow Mx + -Ac + 1	CY
SUBM X (, B)	00011 1bbb xxx xxxx	AC, Mx \leftarrow Mx + -Ac + 1	CY
EOR X (, B)	00100 0bbb xxx xxxx	AC \leftarrow Mx \oplus Ac	
EORM X (, B)	00100 1bbb xxx xxxx	AC, Mx \leftarrow Mx \oplus Ac	
OR X (, B)	00101 0bbb xxx xxxx	AC \leftarrow Mx Ac	
ORM X (, B)	00101 1bbb xxx xxxx	AC, Mx \leftarrow Mx Ac	
AND X (, B)	00110 0bbb xxx xxxx	AC \leftarrow Mx & Ac	
ANDM X (, B)	00110 1bbb xxx xxxx	AC, Mx \leftarrow Mx & Ac	
SHR	11110 0000 000 0000	0 \rightarrow AC [3]; AC [0] \rightarrow CY; AC shift right one bit	CY

Immediate Type

Mnemonic	Instruction Code	Function	Flag Change
ADI X, I	01000 iiii xxx xxxx	AC \leftarrow Mx + I	CY
ADIM X, I	01001 iiii xxx xxxx	AC, Mx \leftarrow Mx + I	CY
SBI X, I	01010 iiii xxx xxxx	AC \leftarrow Mx + -I + 1	CY
SBIM X, I	01011 iiii xxx xxxx	AC, Mx \leftarrow Mx + -I + 1	CY
EORIM X, I	01100 iiii xxx xxxx	AC, Mx \leftarrow Mx \oplus I	
ORIM X, I	01101 iiii xxx xxxx	AC, Mx \leftarrow Mx I	
ANDIM X, I	01110 iiii xxx xxxx	AC, Mx \leftarrow Mx & I	

* In the assembler ASM66 V1.0, EORIM mnemonic is EORI. However, EORI has the same operation identical with EORIM. Same for the ORIM with respect to ORI, and ANDIM with respect to ANDI.

Decimal Adjust

Mnemonic	Instruction Code	Function	Flag Change
DAA X	11001 0110 xxx xxxx	AC; Mx \leftarrow Decimal adjust for add.	CY
DAS X	11001 1010 xxx xxxx	AC; Mx \leftarrow Decimal adjust for sub.	CY



Transfer Instruction

Mnemonic	Instruction Code	Function	Flag Change
LDA X (, B)	00111 0bbb xxx xxxx	AC ← Mx	
STA X (, B)	00111 1bbb xxx xxxx	Mx ← AC	
LDI X, I	01111 iii xxx xxxx	AC, Mx ← I	

Control Instruction

Mnemonic	Instruction Code	Function	Flag Change
BAZ X	10010 xxxx xxx xxxx	PC ← X if AC = 0	
BNZ X	10000 xxxx xxx xxxx	PC ← X if AC ≠ 0	
BC X	10011 xxxx xxx xxxx	PC ← X if CY = 1	
BNC X	10001 xxxx xxx xxxx	PC ← X if CY ≠ 1	
BA0 X	10100 xxxx xxx xxxx	PC ← X if AC (0) = 1	
BA1 X	10101 xxxx xxx xxxx	PC ← X if AC (1) = 1	
BA2 X	10110 xxxx xxx xxxx	PC ← X if AC (2) = 1	
BA3 X	10111 xxxx xxx xxxx	PC ← X if AC (3) = 1	
CALL X	11000 xxxx xxx xxxx	ST ← CY ; PC + 1 PC ← X (Not include p)	
RTNW H, L	11010 000h hhh I I I I	PC ← ST ; TBR ← hhhh; AC ← I I I I	
RTNI	11010 1000 000 0000	CY ; PC ← ST	CY
HALT	11011 0000 000 0000		
STOP	11011 1000 000 0000		
JMP X	1110p xxxx xxx xxxx	PC ← X (Include p)	
TJMP	11110 1111 111 1111	PC ← (PC11-C8) (TBR) (AC)	
NOP	11111 1111 111 1111	No Operation	

Where

PC	Program counter	I	Immediate data	p	ROM page = 0
AC	Accumulator	⊕	Logical exclusive OR	ST	Stack
-AC	Complement of accumulator		Logical OR	TBR	Table Branch Register
CY	Carry flag	&	Logical AND		
Mx	Data memory	bbb	RAM bank = 000		



Absolute Maximum Rating*

DC Supply Voltage -0.3V to + 7.0V
 Input Voltage -0.3V to V_{DD} + 0.3V
 Operating Ambient Temperature -10°C to + 60°C
 Storage Temperature -55°C to + 125°C

***Comments**

Stresses above those listed under "Absolute Maximum Ratings" may cause permanent damage to this device. These are stress ratings only. Functional operation of this device at these or any other conditions above those indicated in the operational sections of this specification is not implied or intended. Exposure to the absolute maximum rating conditions for extended periods may affect device reliability.

DC Electrocal Characteristics

(V_{DD} = 3.0V, GND = 0V, T_A = 25°C, F_{osc} = 32.768KHz, F_{oscx} is not used, unless otherwise specified)

Parameter	Symbol	Min.	Typ.	Max.	Unit	Conditions
Operating Voltage	V _{DD}	2.4	3	6.0	V	
Operating Current	I _{OP}	-	10	20	μA	All output pins unload execute NOP instruction excluding LCD bias current
LCD Voltage Divider Resistor	R _{LCD}	-	275	-	KΩ	
Standby Current	I _{SB1}	-	2	4	μA	All output pins unload (HALT mode) excluding LCD bias current
Standby Current	I _{SB2}	-	-	1	μA	All output pins unload (STOP mode), LCD off
Input High Voltage	V _{IH}	0.7 X V _{DD} 0.85 X V _{DD}	-	V _{DD} + 0.3 V _{DD} + 0.3	V	PORTA, PORTB INT0, RESET
Input Low Voltage	V _{IL}	-0.3	-	0.3 X V _{DD} 0.15 X V _{DD}	V	PORTA, PORTB INT0, RESET
Drive-high Resistance	R _{OH}	-	300	-	KΩ	PORTA, PORTB (I _{OH} = -10μA, V _{OH} = 0)
Output High Voltage	V _{OH1}	0.7 X V _{DD}	-	-	V	PORTA.0, PORTA.3, PORTB (I _{OH} = -2mA)
Output Low Voltage	V _{OL1}	-	-	0.8	V	PORTA.0, PORTA.3, PORTB (I _{OL} = 2mA)
Output High Voltage	V _{OH2}	0.7 X V _{DD}	-	-	V	PORTA.1, PORTA.2 or PSG output, I _{OH} = -5mA
Output Low Voltage	V _{OL2}	-	-	0.8	V	PORTA.1, PORTA.2 or PSG output, I _{OL} = 5mA
Output High Voltage	V _{OH3}	2.8	-	-	V	SEGx, C = 50P, rise time < 1000ns
Output Low Voltage	V _{OL3}	-	-	0.2	V	SEGx
Output High Voltage	V _{OH4}	V _{DD} - 0.6	-	-	V	SEG1 - 30to be output port, I _{OH} = -1mA
Output Low Voltage	V _{OL4}	-	-	0.8	V	SEG1 - 30to be output port, I _{OL} = 1mA
Output High Voltage	V _{OH5}	V _{DD} - 1.0	-	-	V	COMx, I _{OH} = -1mA
Output Low Voltage	V _{OL5}	-	-	0.8	V	COMx, I _{OL} = 1mA
LCD Lighting	I _{LCD}	-	8	10	μA	V _{DD} = 3V, excluding CPU core operation current

Operation frequency vs. I_{SB1}
 I_{SB1X} = (Frequency/32.768KHz) X I_{SB1} X 0.8, (V_{DD} = 3.0V).

Operation frequency vs. I_{OP}
 I_{OPX} = (Frequency/32.768KHz) X I_{OP} X 0.8, (V_{DD} = 3.0V).

HLM vs. I_{OP}, I_{SB1} and I_{SB2}
 If HLM = 1, I_{OPX} = I_{OP} X 2, I_{SB2X} = I_{SB2} X 2.

DC Electrocal Characteristics

 (V_{DD} = 5.0V, GND = 0V, T_A = 25°C, F_{osc} = 32.768KHz, F_{oscx} is not used, unless otherwise specified)

Parameter	Symbol	Min.	Typ.	Max.	Unit	Conditions
Operating Voltage	V _{DD}	2.4	5.0	6.0	V	
Operating Current	I _{OP}	-	20	40	μA	All output pins unload execute NOP instruction excluding LCD bias current
LCD Voltage Divider Resistor	R _{LCD}	-	275	-	KΩ	
Standby Current	I _{SB1}	-	5	10	μA	All output pins unload (HALT mode) excluding LCD bias current
Standby Current	I _{SB2}	-	-	1	μA	All output pins unload (STOP mode), LCD off
Input High Voltage	V _{IH}	0.7 X V _{DD} 0.85 X V _{DD}	-	V _{DD} + 0.3 V _{DD} + 0.3	V	PORTA, PORTB $\overline{\text{INT0}}$, $\overline{\text{RESET}}$
Input Low Voltage	V _{IL}	-0.3	-	0.3 X V _{DD} 0.15 X V _{DD}	V	PORTA, PORTB $\overline{\text{INT0}}$, $\overline{\text{RESET}}$
Drive-high Resistance	R _{OH}	-	300	-	KΩ	PORTA, PORTB (I _{OH} = -10μA, V _{OH} = 0)
Output High Voltage	V _{OH1}	0.7 X V _{DD}	-	-	V	PORTA.0, PORTA.3, PORTB (I _{OH} = -3mA)
Output Low Voltage	V _{OL1}	-	-	0.8	V	PORTA.0, PORTA.3, PORTB (I _{OL} = 3mA)
Output High Voltage	V _{OH2}	0.7 X V _{DD}	-	-	V	PORTA.1, PORTA.2 or PSG output, I _{OH} = -7mA
Output Low Voltage	V _{OL2}	-	-	0.8	V	PORTA.1, PORTA.2 or PSG output, I _{OL} = 7mA
Output High Voltage	V _{OH3}	4.8	-	-	V	SEGx, C = 50P, rise time < 1000ns
Output Low Voltage	V _{OL3}	-	-	0.2	V	SEGx
Output High Voltage	V _{OH4}	V _{DD} - 0.6	-	-	V	SEG1-30to be output port, I _{OH} = -1mA
Output Low Voltage	V _{OL4}	-	-	0.8	V	SEG1-30to be output port, I _{OL} = 1mA
Output High Voltage	V _{OH5}	V _{DD} - 1.0	-	-	V	COMx, I _{OH} = -1mA
Output Low Voltage	V _{OL5}	-	-	0.8	V	COMx, I _{OL} = 1mA
LCD Lighting	I _{LCD}	-	12	15	μA	V _{DD} = 5.0V, excluding CPU core operation current

 Operation frequency vs. I_{SB1}

$$I_{SB1x} = (\text{Frequency}/32.768\text{KHz}) \times I_{SB1} \times 0.8, (V_{DD} = 5.0V).$$

 Operation frequency vs. I_{OP}

$$I_{OPx} = (\text{Frequency}/32.768\text{KHz}) \times I_{OP} \times 0.8, (V_{DD} = 5.0V).$$

 HLM vs. I_{OP}, I_{SB1} and I_{SB2}

$$\text{If HLM} = 1, I_{OPx} = I_{OP} \times 2, I_{SB2x} = I_{SB2} \times 2.$$



SH6614D

AC Characteristics ($V_{DD} = 3.0V$, $GND = 0V$, $TA = 25^{\circ}C$, $FOSC = 32.768KHz$, unless otherwise specified)

Parameter	Symbol	Min.	Typ.	Max.	Unit	Conditions
Oscillation Start Time	tSTT	-	2	5	s	
Frequency Stability	$ \Delta F /F$	-	-	1	PPM	[F(3.0)-F(2.5)] / F (3.0), crystal oscillator

AC Characteristics ($V_{DD} = 5.0V$, $GND = 0V$, $TA = 25^{\circ}C$, $FOSC = 32.768KHz$, unless otherwise specified)

Parameter	Symbol	Min.	Typ.	Max.	Unit	Conditions
Oscillation Start Time	tSTT	-	2	5	s	
Frequency Stability	$ \Delta F /F$	-	-	1	PPM	[F(5.0)-F(4.5)] / F (5.0), crystal oscillator

AC Characteristics ($V_{DD} = 3.0V$, $GND = 0V$, $TA = 25^{\circ}C$, $FOSC = 262KHz$, $FOSC_X$ stop, unless otherwise specified)

Parameter	Symbol	Min.	Typ.	Max.	Unit	Conditions
Oscillation Start Time	tSTT	-	-	100	μs	
Frequency Stability	$ \Delta F /F$	-	-	10	%	[F(3.0)-F(2.5)] / F (3.0), Bias resistance accuracy within 1%

AC Characteristics ($V_{DD} = 4.5V$, $GND = 0V$, $TA = 25^{\circ}C$, $FOSC = 262KHz$, $FOSC_X$ stop, unless otherwise specified)

Parameter	Symbol	Min.	Typ.	Max.	Unit	Conditions
Frequency Stability	$ \Delta F /F$	-	-	10	%	[F(4.5)-F(3.6)] / F (4.5), Bias resistance accuracy within 1%



Typical RC Oscillator Resistor vs. V_{DD}:
(Reference only)

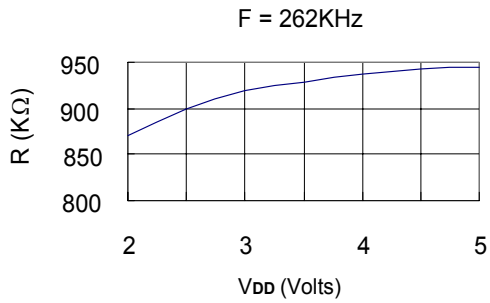

Typical RC Oscillator Frequency vs. V_{DD}:
(Reference only)

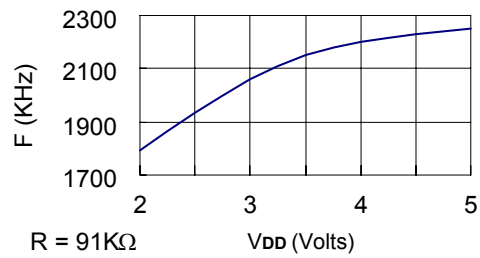
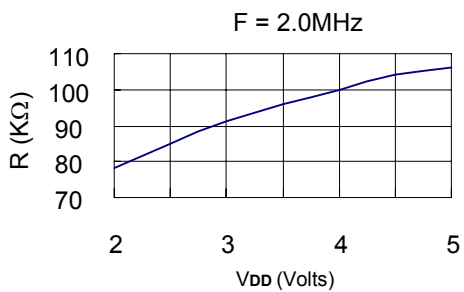
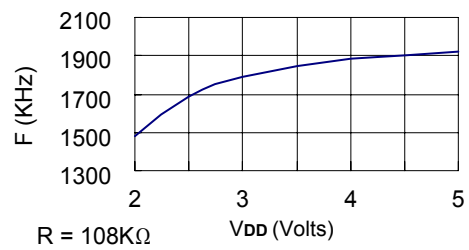
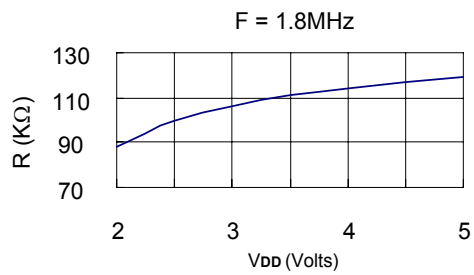
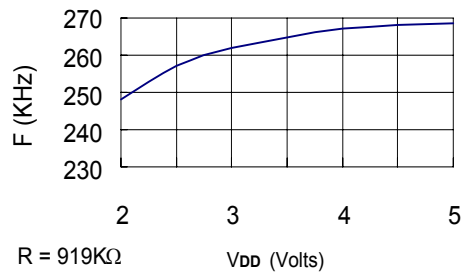



Application Circuit (for reference only)

AP1:

- OSC: Crystal oscillator 32.768KHz (mask option)
- OSCX: Ceramic oscillator 455KHz
- PORTB: I/O
- PORTA.1, PORTA.2: ALARM output
- LCD: Internal LCD 1/8 duty, 1/4 bias

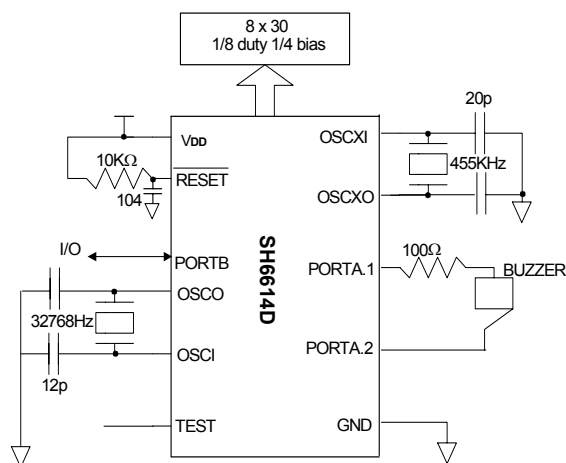

AP2:

- OSC: RC oscillator 262KHz (mask option)
- LCD: Internal LCD 1/4 duty, 1/3 bias
- PORTA, PORTB: I/O
- PORTA.0: External interrupt

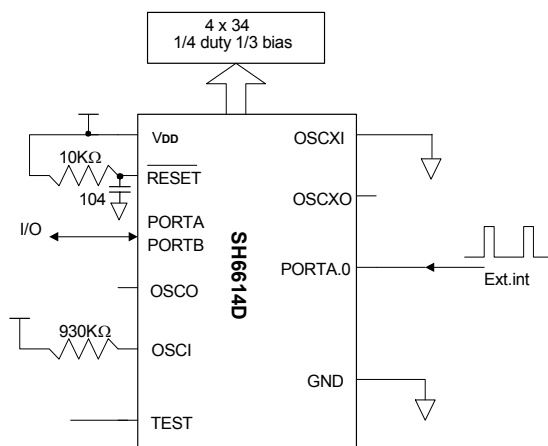



AP3:

- OSC: Crystal oscillator 32.768KHz (mask option)
- OSCX: RC oscillator 1.8MHz
- PORTB: I/O
- PORTA.1: PSG output
- PORTA.2: $\overline{\text{PSG}}$ output

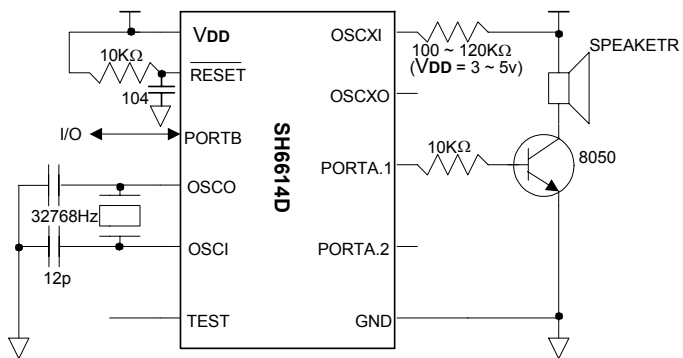

AP4:

Internal LCD bias. 1/8 DUTY 1/4 bias

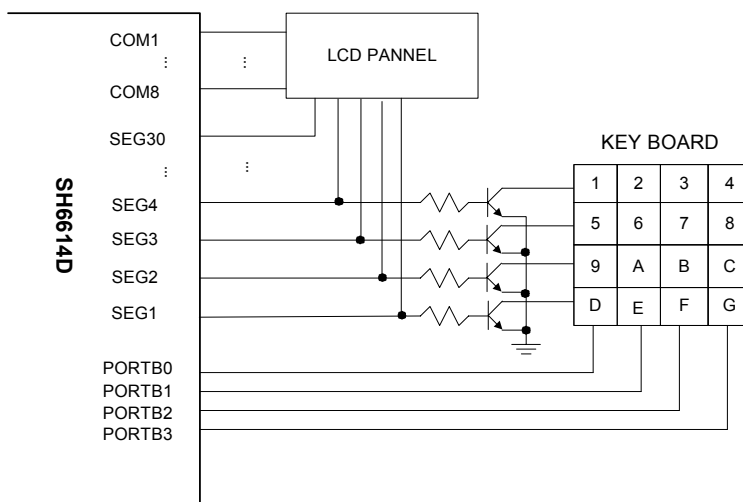

SEG1 - SEG4 as SCAN output



AP5:

Large LCD pannel: External LCD bias

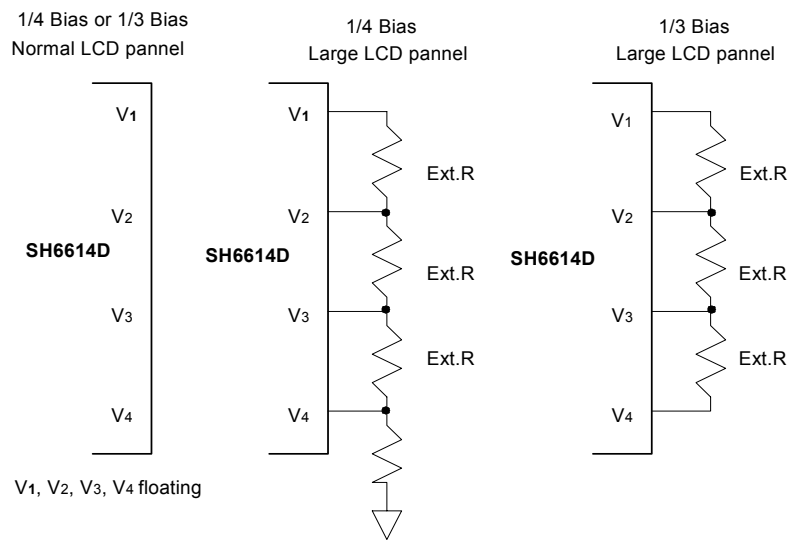



Music Table 1.

Following is the music scale reference table for channel 1 (or channel 2) under OSCX = 1.8MHz. (Up to 6 octaves are possible)
 Music scale data for 1.8M OSCX and SEL0 = SEL1 = 1

Note	Ideal freq.	N	OCT1/OCT2	LSFR (C1.6~C1.0) (C2.14~C2.8)	Real freq.	Error%	Note	Ideal freq.	N	OCT1/OCT2	LSFR (C1.6~C1.0) (C2.14~C2.8)	Real freq.	Error%
B1	61.73	114	1	42	61.68	-0.08	B4	493.88	114	0	42	493.42	-0.09
C2	65.10	108	1	23	65.10	0.01	C5	523.25	108	0	23	520.83	-0.46
#C2	69.29	101	1	64	69.62	0.47	#C5	554.35	101	0	64	556.93	0.47
D2	73.42	96	1	0B	73.24	-0.24	D5	587.33	96	0	0B	585.94	-0.24
#D2	77.78	90	1	4E	78.13	0.44	#D5	622.24	90	0	4E	625.00	0.44
E2	82.41	85	1	54	82.72	0.38	E5	659.26	85	0	54	661.77	0.38
F2	87.31	81	1	4F	86.81	-0.58	F5	698.46	81	0	4F	694.44	-0.58
#F2	92.50	76	1	74	92.52	0.02	#F5	739.97	76	0	74	740.13	0.02
G2	98.00	72	1	43	97.66	-0.35	G5	783.99	72	0	43	781.25	-0.35
#G2	103.82	68	1	38	103.40	-0.40	#G5	830.59	68	0	38	827.21	-0.41
A2	110.00	64	1	9	109.86	-0.13	A5	880.00	64	0	9	878.91	-0.12
#A2	116.54	60	1	13	117.19	0.56	#A5	932.31	60	0	13	937.50	0.56
B2	123.47	57	1	1B	123.36	-0.09	B5	987.77	57	0	1B	986.84	-0.09
C3	130.81	54	1	5A	130.21	-0.46	C6	1046.48	54	0	5A	1041.67	-0.46
#C3	138.59	51	1	56	137.87	-0.52	#C6	1108.71	51	0	56	1102.94	-0.52
D3	146.83	48	1	37	146.48	-0.24	D6	1174.63	48	0	37	1171.88	-0.24
#D3	155.56	45	1	3D	156.25	0.44	#D6	1244.48	45	0	3D	1250.00	0.44
E3	164.81	43	1	76	163.52	-0.79	E6	1318.48	43	0	76	1308.14	-0.78
F3	174.61	40	1	31	175.78	0.67	F6	1396.88	40	0	31	1406.25	0.67
#F3	184.99	38	1	46	185.03	0.02	#F6	1479.95	38	0	46	1480.26	0.02
G3	196.00	36	1	1A	195.31	-0.35	G6	1567.95	36	0	1A	1562.50	-0.35
#G3	207.65	34	1	69	206.80	-0.41	#G6	1661.18	34	0	69	1654.41	-0.41
A3	220.00	32	1	25	219.73	-0.12	A6	1759.96	32	0	25	1757.81	-0.12
#A3	233.08	30	1	17	234.38	0.56	#A6	1864.62	30	0	17	1875.00	0.56
B3	246.94	28	1	5D	251.12	1.69	B6	1975.49	28	0	5D	2008.93	1.69
C4	261.63	27	1	3B	260.42	-0.46	C7	2092.96	27	0	3B	2083.33	-0.46
#C4	277.18	25	1	6E	281.25	1.47	#C7	2217.41	25	0	6E	2250.00	1.47
D4	293.66	24	1	5C	292.97	-0.24	D7	2349.27	24	0	5C	2343.75	-0.24
#D4	311.12	23	1	39	305.71	-1.74	#D7	2488.96	23	0	39	2445.65	-1.74
E4	329.63	21	1	66	334.82	1.58	E7	2636.96	21	0	66	2678.57	1.58
F4	349.23	20	1	4C	351.56	0.67	F7	2793.77	20	0	4C	2812.50	0.67
#F4	369.99	19	1	19	370.07	0.02	#F7	2959.89	19	0	19	2960.53	0.02
G4	392.00	18	1	32	390.63	-0.35	G7	3135.90	18	0	32	3125.00	-0.35
#G4	415.30	17	1	65	413.60	-0.41	#G7	3322.37	17	0	65	3308.82	-0.41
A4	440.00	16	1	4A	439.45	-0.12	A7	3519.93	16	0	4A	3515.63	-0.12
#A4	466.15	15	1	15	468.75	0.56	#A7	3729.23	15	0	15	3750.00	0.56
B4	493.88	14	1	2A	502.23	1.69	B7	3950.98	14	0	2A	4017.86	1.69



Music Table 2.

Following is the music scale reference table for channel 1 (or channel 2) under OSC = 32.768KHz. (Up to 4 octaves are possible) Music scale data for 32K OSC and SEL0 = SEL1 = 0

Note	Ideal freq.	N	OCT1 /OCT2	LSFR (C1.6~C1.0) (C2.14~C2.8)	Real freq.	Error%	Note	Ideal freq.	N	OCT1 /OCT2	LSFR (C1.6~C1.0) (C2.14~C2.8)	Real freq.	Error%
A1	55.00	37	1	0D	55.35	0.64	C4	261.63	63	0	12	260.06	-0.60
#A1	58.27	35	1	34	58.51	0.42	#C4	277.18	59	0	26	277.70	0.19
B1	61.73	33	1	52	62.06	0.54	D4	293.66	56	0	36	292.57	-0.37
C2	65.41	31	1	4B	66.07	1.00	#D4	311.12	53	0	35	309.13	-0.64
#C2	69.29	30	1	17	68.27	-1.48	E4	329.63	50	0	2D	327.68	-0.59
D2	73.42	28	1	5D	73.14	-0.38	F4	349.23	47	0	6F	348.60	-0.18
#D2	77.78	26	1	77	78.77	1.27	#F4	369.99	44	0	7B	372.36	0.64
E2	82.41	25	1	6E	81.92	-0.60	G4	392.00	42	0	6C	390.10	-0.49
F2	87.31	23	1	39	89.04	1.99	#G4	415.30	39	0	63	420.10	1.16
#F2	92.50	22	1	73	93.09	0.64	A4	440.00	37	0	0D	442.81	0.64
G2	98.00	21	1	66	97.52	-0.49	#A4	466.15	35	0	34	468.11	0.42
#G2	103.82	20	1	4C	102.40	-1.37	B4	493.88	33	0	52	496.49	0.53
A2	110.00	19	1	19	107.79	-2.01	C5	523.25	31	0	4B	528.52	1.01
#A2	116.54	18	1	32	113.78	-2.37	#C5	554.35	30	0	17	546.13	-1.48
B2	123.47	17	1	65	120.47	-2.43	D5	587.33	28	0	5D	585.14	-0.37
C3	130.81	16	1	4	128.00	-2.15	#D5	622.24	26	0	77	630.15	1.27
#C3	138.59	15	1	0C	136.53	-1.48	E5	659.26	25	0	6E	655.36	-0.59
D3	146.83	112	0	0A	146.29	-0.37	F5	698.46	23	0	39	712.35	1.99
#D3	155.56	105	0	1E	156.04	0.31	#F5	739.97	22	0	73	744.73	0.64
E3	164.81	99	0	11	165.50	0.42	G5	783.99	21	0	66	780.19	-0.49
F3	174.61	94	0	2C	174.30	-0.18	#G5	830.59	20	0	4C	819.20	-1.37
#F3	184.99	89	0	1D	184.09	-0.49	A5	880.00	19	0	19	862.32	-2.01
G3	196.00	84	0	29	195.05	-0.49	#A5	932.31	18	0	32	910.22	-2.37
#G3	207.65	79	0	3E	207.39	-0.12	B5	987.77	17	0	65	963.77	-2.43
A3	220.00	74	0	50	221.41	0.64	C6	1046.48	16	0	4A	1024.00	-2.15
#A3	233.08	70	0	0E	234.06	0.42	#C6	1108.71	15	0	15	1092.27	-1.48
B3	246.94	66	0	62	248.24	0.53	D6	1174.63	14	0	2A	1170.29	-0.37



Bonding Diagram

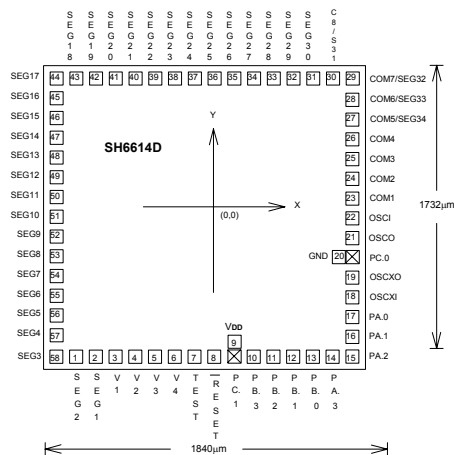

Substrate connect to GND

Pad No.	Designation	X (µm)	Y (µm)	Pad No.	Designation	X (µm)	Y (µm)
1	SEG [2]	-688.50	-756.00	29	COM [7]	814.50	756.00
2	SEG [1]	-571.50	-756.00	30	COM [8]	697.50	756.00
3	V ₁	-463.50	-756.00	31	SEG [30]	580.50	756.00
4	V ₂	-360.00	-756.00	32	SEG [29]	472.50	756.00
5	V ₃	-256.50	-756.00	33	SEG [28]	369.00	756.00
6	V ₄	-153.00	-756.00	34	SEG [27]	265.50	756.00
7	TEST	-49.50	-756.00	35	SEG [26]	162.00	756.00
8	RESET	54.00	-756.00	36	SEG [25]	58.50	756.00
9	V _{DD}	166.50	-671.40	37	SEG [24]	-49.50	756.00
bonding option	PORTC [1]	166.50	-756.00	38	SEG [23]	-153.00	756.00
10	PORTB.3	270.00	-756.00	39	SEG [22]	-256.50	756.00
11	PORTB.2	373.50	-756.00	40	SEG [21]	-360.00	756.00
12	PORTB.1	477.00	-756.00	41	SEG [20]	-463.50	756.00
13	PORTB.0	580.50	-756.00	42	SEG [19]	-571.50	756.00
14	PORTA.3	697.50	-756.00	43	SEG [18]	-688.50	756.00
15	PORTA.2	814.50	-756.00	44	SEG [17]	-814.50	756.00
16	PORTA.1	814.50	-639.00	45	SEG [16]	-814.50	639.00
17	PORTA.0	814.50	-531.00	46	SEG [15]	-814.50	531.00
18	OSCXI	814.50	-423.00	47	SEG [14]	-814.50	423.00
19	OSCXO	814.50	-319.50	48	SEG [13]	-814.50	319.50
20	GND	729.90	-216.00	49	SEG [12]	-814.50	216.00
bonding option	PORTC [0]	814.50	-216.00	50	SEG [11]	-814.50	108.00
21	OSCO	814.50	-108.00	51	SEG [10]	-814.50	0.00
22	OSCI	814.50	0.00	52	SEG [9]	-814.50	-108.00
23	COM [1]	814.50	108.00	53	SEG [8]	-814.50	-216.00
24	COM [2]	814.50	216.00	54	SEG [7]	-814.50	-319.50
25	COM [3]	814.50	319.50	55	SEG [6]	-814.50	-423.00
26	COM [4]	814.50	423.00	56	SEG [5]	-814.50	-531.00
27	COM [5]	814.50	531.00	57	SEG [4]	-814.50	-639.00
28	COM [6]	814.50	639.00	58	SEG [3]	-814.50	-756.00



SH6614D

Ordering Informations

Part No.	Packages
SH6614DH	CHIP FORM
SH6614DF	QFP 100
SH6614DF_64	QFP 64



SH6614D

Package Informations

QFP 64L Outline Dimensions

unit: inches/mm

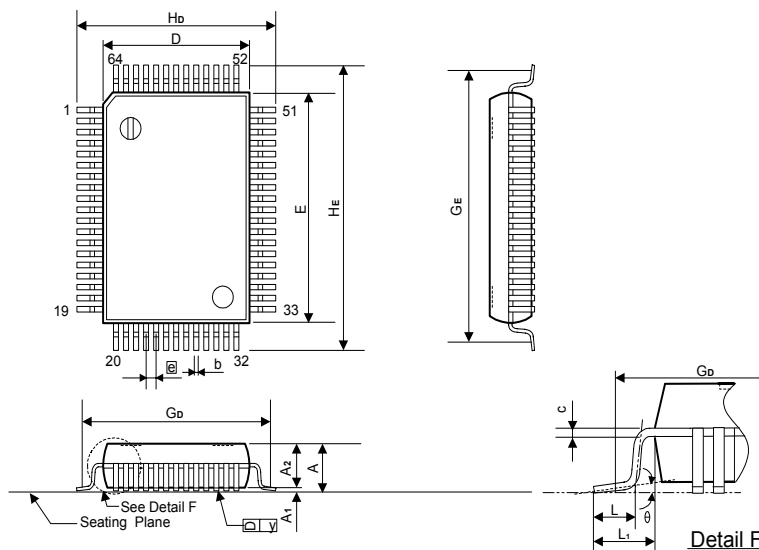

Symbol	Dimensions in inches	Dimensions in mm
A	0.130 Max.	3.30 Max.
A ₁	0.004 Min.	0.10 Min.
A ₂	0.112 ± 0.005	2.85 ± 0.13
b	0.016 +0.004 -0.002	0.40 +0.10 -0.05
c	0.006 +0.004 -0.002	0.15 +0.10 -0.05
D	0.551 ± 0.005	14.00 ± 0.13
E	0.787 ± 0.005	20.00 ± 0.13
e	0.039 ± 0.006	1.00 ± 0.15
G _D	0.693 NOM.	17.60 NOM.
G _E	0.929 NOM.	23.60 NOM.
H _D	0.740 ± 0.012	18.80 ± 0.31
H _E	0.976 ± 0.012	24.79 ± 0.31
L	0.047 ± 0.008	1.19 ± 0.20
L ₁	0.095 ± 0.008	2.41 ± 0.20
y	0.006 Max.	0.15 Max.
θ	0° ~ 12°	0° ~ 12°

Notes:

1. Dimensions D & E do not include resin fins.
2. Dimensions G_D & G_E are for PC Board surface mount pad pitch design reference only.



SH6614D

QFP 100L Outline Dimensions

unit: inches/mm

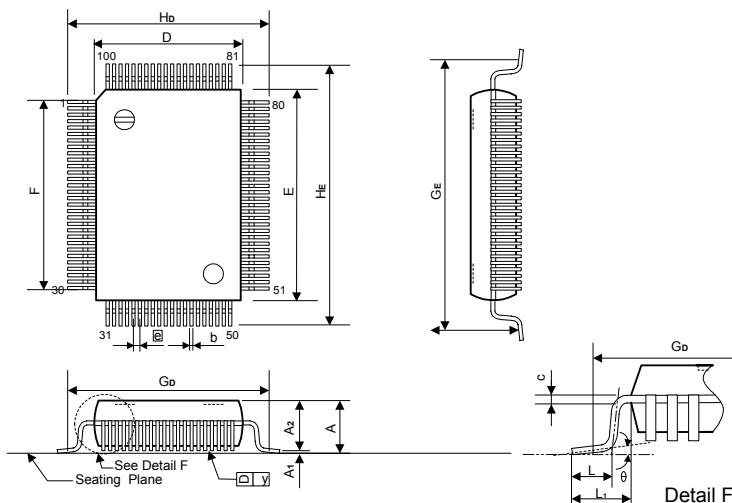

Symbol	Dimensions in inches	Dimensions in mm
A	0.130 Max.	3.30 Max.
A1	0.004 Min.	0.10 Min.
A2	0.112 ± 0.005	2.85 ± 0.13
b	0.012 +0.004 -0.002	0.31 +0.10 -0.05
c	0.006 +0.004 -0.002	0.15 +0.10 -0.05
D	0.551 ± 0.005	14.00 ± 0.13
E	0.787 ± 0.005	20.00 ± 0.13
e	0.026 ± 0.006	0.65 ± 0.15
F	0.742 NOM.	18.85 NOM.
GD	0.693 NOM.	17.60 NOM.
GE	0.929 NOM.	23.60 NOM.
HD	0.740 ± 0.012	18.80 ± 0.31
HE	0.976 ± 0.012	24.79 ± 0.31
L	0.047 ± 0.008	1.19 ± 0.20
L1	0.095 ± 0.008	2.41 ± 0.20
y	0.006 Max.	0.15 Max.
θ	0° ~ 12°	0° ~ 12°

Notes:

1. Dimensions D&E do not include resin fins.
2. Dimensions GD & GE are for PC Board surface mount pad pitch design reference only.