

**Features**

- 2.2 GHz operation
- $\div 10/11$  dual modulus prescaler
- Internal phase detector
- Serial programmable
- Low power—15 mA at 3 V
- Ultra-low phase noise
- Available in 20-lead TSSOP

**Product Description**

Peregrine's PE3240 is a high performance integer-N PLL capable of frequency synthesis up to 2.2 GHz. The superior phase noise performance of the PE3240 is ideal for applications such as wireless local loop basestations, LMDS systems and other demanding terrestrial systems.

The PE3240 features a 10/11 dual modulus prescaler, counters and a phase comparator as shown in Figure 1. Counter values are programmable through a three wire serial interface.

The PE3240 is manufactured on Peregrine's UltraCMOS™ process, a patented variation of silicon-on-insulator (SOI) technology on a sapphire substrate, offering the performance of GaAs with the economy and integration of conventional CMOS.

**Figure 1. Block Diagram**

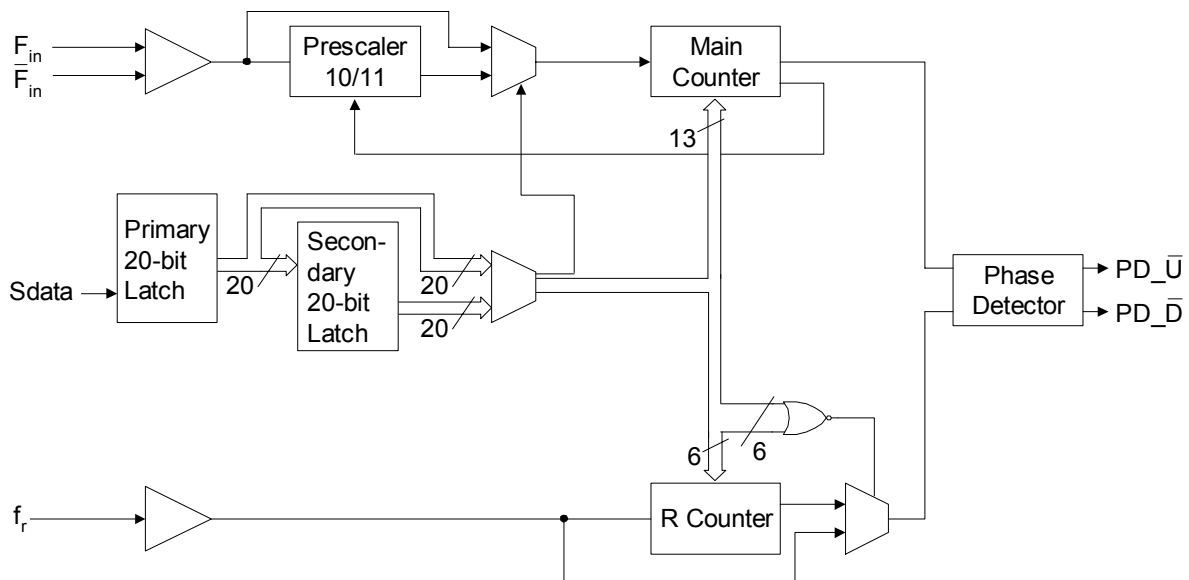

**Figure 2. Pin Configuration (Top View)**

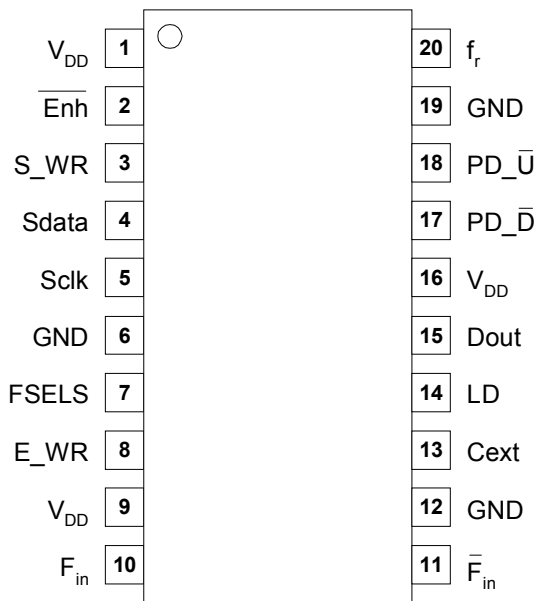

**Figure 3. Package Type**

20-lead TSSOP



**Table 1. Pin Descriptions**

Pin No.	Pin Name	Type	Description
1	V <sub>DD</sub>	(Note 1)	Power supply input. Input may range from 2.85 V to 3.15 V. Bypassing required.
2	$\overline{\text{Enh}}$	Input	Enhancement mode. When asserted low ("0"), enhancement register bits are functional. Internal 70 kΩ pull-up resistor.
3	S <sub>WR</sub>	Input	Serial load enable input. While S <sub>WR</sub> is "low", Sdata can be serially clocked. Primary register data are transferred to the secondary register on S <sub>WR</sub> rising edge.
4	Sdata	Input	Binary serial data input. Input data entered MSB first.
5	Sclk	Input	Serial clock input. Sdata is clocked serially into the 20-bit primary register (E <sub>WR</sub> "low") or the 8-bit enhancement register (E <sub>WR</sub> "high") on the rising edge of Sclk.
6	GND		Ground.
7	FSELS	Input	Selects contents of primary register (FSELS=1) or secondary register (FSELS=0) for programming of internal counters. Internal 70 kΩ pull-down resistor.
8	E <sub>WR</sub>	Input	Enhancement register write enable. While E <sub>WR</sub> is "high", Sdata can be serially clocked into the enhancement register on the rising edge of Sclk. Internal 70 kΩ pull-down resistor.
9	V <sub>DD</sub>	(Note 1)	Same as pin 1.
10	Fin	Input	Prescaler input from the VCO. Max frequency input is 2.2 GHz.
11	$\overline{\text{Fin}}$	Input	Prescaler complementary input. A bypass capacitor should be placed as close as possible to this pin and be connected in series with a 50 Ω resistor to the ground plane.
12	GND		Ground.
13	Cext	Output	Logical "NAND" of PD <sub>U</sub> and PD <sub>D</sub> terminated through an on chip, 2 kΩ series resistor. Connecting Cext to an external capacitor will low pass filter the input to the inverting amplifier used for driving LD.
14	LD	Output	Lock detect is an open drain logical inversion of CEXT. When the loop is in lock, LD is high impedance, otherwise LD is a logic low ("0").
15	Dout	Output	Data out function, Dout, enabled in enhancement mode.
16	V <sub>DD</sub>	(Note 1)	Same as pin 1.

**Table 1. Pin Descriptions (continued)**

Pin No.	Pin Name	Type	Description
17	PD_D	Output	PD_D pulses down when $f_p$ leads $f_c$ .
18	PD_U	Output	PD_U pulses down when $f_c$ leads $f_p$ .
19	GND		Ground.
20	$f_r$	Input	Reference frequency input.

**Note 1:**  $V_{DD}$  pins 1, 9, and 16 are connected by diodes and must be supplied with the same positive voltage level.

**Table 2. Absolute Maximum Ratings**

Symbol	Parameter/Conditions	Min	Max	Units
$V_{DD}$	Supply voltage	-0.3	4.0	V
$V_I$	Voltage on any input	-0.3	$V_{DD} + 0.3$	V
$I_I$	DC into any input	-10	+10	mA
$I_O$	DC into any output	-10	+10	mA
$T_{stg}$	Storage temperature range	-65	150	°C

### Electrostatic Discharge (ESD) Precautions

When handling this UltraCMOS™ device, observe the same precautions that you would use with other ESD-sensitive devices. Although this device contains circuitry to protect it from damage due to ESD, precautions should be taken to avoid exceeding the specified rating in Table 4.

### Latch-Up Avoidance

Unlike conventional CMOS devices, UltraCMOS™ devices are immune to latch-up.

**Table 3. Operating Ratings**

Symbol	Parameter/Conditions	Min	Max	Units
$V_{DD}$	Supply voltage	2.85	3.15	V
$T_A$	Operating ambient temperature range	-40	85	°C

**Table 4. ESD Ratings**

Symbol	Parameter/Conditions	Level	Units
$V_{ESD}$	ESD voltage human body model (Note 1)	1000	V

**Note 1:** Periodically sampled, not 100% tested. Tested per MIL-STD-883, M3015 C2

**Table 5. DC Characteristics:**  $V_{DD} = 3.0\text{ V}$ ,  $-40^\circ\text{ C} < T_A < 85^\circ\text{ C}$ , unless otherwise specified

Symbol	Parameter	Conditions	Min	Typ	Max	Units
$I_{DD}$	Operational supply current; Prescaler enabled	$V_{DD} = 2.85\text{ to }3.15\text{ V}$		15	20	mA
Digital Inputs: S_WR, Sdata, Sclk						
$V_{IH}$	High level input voltage	$V_{DD} = 2.85\text{ to }3.15\text{ V}$	$0.7 \times V_{DD}$			V
$V_{IL}$	Low level input voltage	$V_{DD} = 2.85\text{ to }3.15\text{ V}$			$0.3 \times V_{DD}$	V
$I_{IH}$	High level input current	$V_{IH} = V_{DD} = 3.15\text{ V}$			+1	$\mu\text{A}$
$I_{IL}$	Low level input current	$V_{IL} = 0, V_{DD} = 3.15\text{ V}$	-1			$\mu\text{A}$
Digital inputs: $\overline{\text{Enh}}$ (contains a 70 k $\Omega$ pull-up resistor)						
$V_{IH}$	High level input voltage	$V_{DD} = 2.85\text{ to }3.15\text{ V}$	$0.7 \times V_{DD}$			V
$V_{IL}$	Low level input voltage	$V_{DD} = 2.85\text{ to }3.15\text{ V}$			$0.3 \times V_{DD}$	V
$I_{IH}$	High level input current	$V_{IH} = V_{DD} = 3.15\text{ V}$			+1	$\mu\text{A}$
$I_{IL}$	Low level input current	$V_{IL} = 0, V_{DD} = 3.15\text{ V}$	-100			$\mu\text{A}$
Digital inputs: FSELS, E_WR (contains a 70 k $\Omega$ pull-down resistor)						
$V_{IH}$	High level input voltage	$V_{DD} = 2.85\text{ to }3.15\text{ V}$	$0.7 \times V_{DD}$			V
$V_{IL}$	Low level input voltage	$V_{DD} = 2.85\text{ to }3.15\text{ V}$			$0.3 \times V_{DD}$	V
$I_{IH}$	High level input current	$V_{IH} = V_{DD} = 3.15\text{ V}$			+100	$\mu\text{A}$
$I_{IL}$	Low level input current	$V_{IL} = 0, V_{DD} = 3.15\text{ V}$	-1			$\mu\text{A}$
Reference Divider input: $f_r$						
$I_{IHR}$	High level input current	$V_{IH} = V_{DD} = 3.15\text{ V}$			+100	$\mu\text{A}$
$I_{ILR}$	Low level input current	$V_{IL} = 0, V_{DD} = 3.15\text{ V}$	-100			$\mu\text{A}$
Counter and phase detector outputs: Dout, PD_D, PD_U						
$V_{OLD}$	Output voltage LOW	$I_{out} = 6\text{ mA}$			0.4	V
$V_{OHD}$	Output voltage HIGH	$I_{out} = -3\text{ mA}$	$V_{DD} - 0.4$			V
Lock detect outputs: (Cext, LD)						
$V_{OLC}$	Output voltage LOW, Cext	$I_{out} = 0.1\text{ mA}$			0.4	V
$V_{OHC}$	Output voltage HIGH, Cext	$I_{out} = -0.1\text{ mA}$	$V_{DD} - 0.4$			V
$V_{OLLD}$	Output voltage LOW, LD	$I_{out} = 1\text{ mA}$			0.4	V

**Table 6. AC Characteristics:**  $V_{DD} = 3.0\text{ V}$ ,  $-40^{\circ}\text{ C} < T_A < 85^{\circ}\text{ C}$ , unless otherwise specified

Symbol	Parameter	Conditions	Min	Max	Units
Control Interface and Latches (see Figures 6, 7)					
$f_{\text{CLK}}$	Serial data clock frequency	(Note 1)		10	MHz
$t_{\text{CLKH}}$	Serial clock HIGH time		30		ns
$t_{\text{CLKL}}$	Serial clock LOW time		30		ns
$t_{\text{DSU}}$	Sdata set-up time to Sclk rising edge		10		ns
$t_{\text{DHLD}}$	Sdata hold time after Sclk rising edge		10		ns
$t_{\text{PW}}$	S_WR pulse width		30		ns
$t_{\text{CWR}}$	Sclk rising edge to S_WR rising edge		30		ns
$t_{\text{CE}}$	Sclk falling edge to E_WR transition		30		ns
$t_{\text{WRC}}$	S_WR falling edge to Sclk rising edge		30		ns
$t_{\text{EC}}$	E_WR transition to Sclk rising edge		30		ns
Main Divider (Including Prescaler)					
$F_{\text{in}}$	Operating frequency		200	2200	MHz
$P_{\text{Fin}}$	Input level range	External AC coupling	-5	5	dBm
Main Divider (Prescaler Bypassed)					
$F_{\text{in}}$	Operating frequency		20	220	MHz
$P_{\text{Fin}}$	Input level range	External AC coupling	-5	5	dBm
Reference Divider					
$f_r$	Operating frequency	(Note 3)		100	MHz
$P_{\text{fr}}$	Reference input power (Note 2)	Single ended input	-2		dBm
Phase Detector					
$f_c$	Comparison frequency	(Note 3)		20	MHz
SSB Phase Noise ( $F_{\text{in}} = 1.3\text{ GHz}$ , $f_r = 10\text{ MHz}$ , $f_c = 1.25\text{ MHz}$ , $\text{LBW} = 70\text{ kHz}$ , $V_{\text{DD}} = 3.0\text{ V}$ , $\text{Temp} = -40^{\circ}\text{ C}$ )					
		100 Hz Offset		-75	dBc/Hz
		1 kHz Offset		-85	dBc/Hz

**Note 1:** fclk is verified during the functional pattern test. Serial programming sections of the functional pattern are clocked at 10 MHz to verify fclk specification.

**Note 2:** CMOS logic levels can be used to drive reference input if DC coupled. Voltage input needs to be a minimum of 0.5 Vp-p. For optimum phase noise performance, the reference input falling edge rate should be faster than 80mV/ns.

**Note 3:** Parameter is guaranteed through characterization only and is not tested.

**Typical Performance Data ( $V_{DD} = 3.0\text{ V}$ ,  $T_A = 25^\circ\text{C}$ )**

**Figure 4. Typical RF Input Sensitivity**

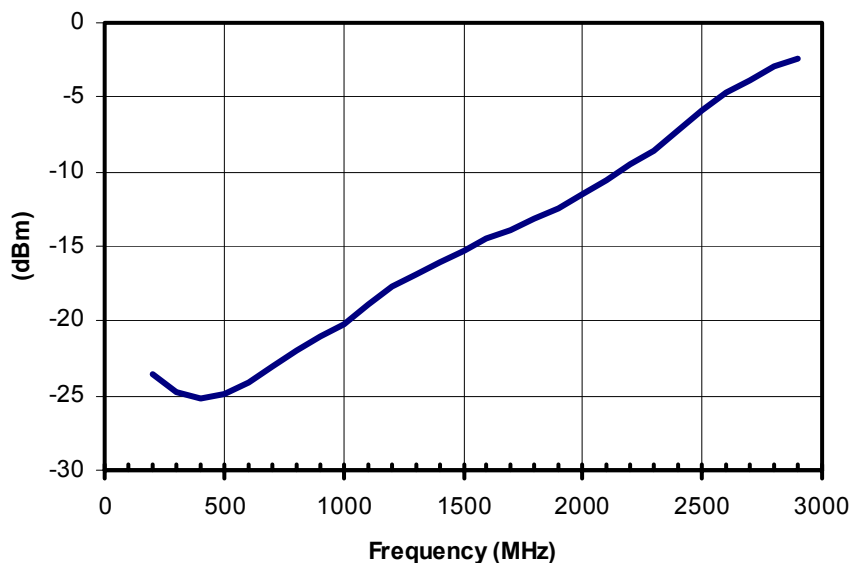

**Figure 5. Typical Phase Noise Performance**

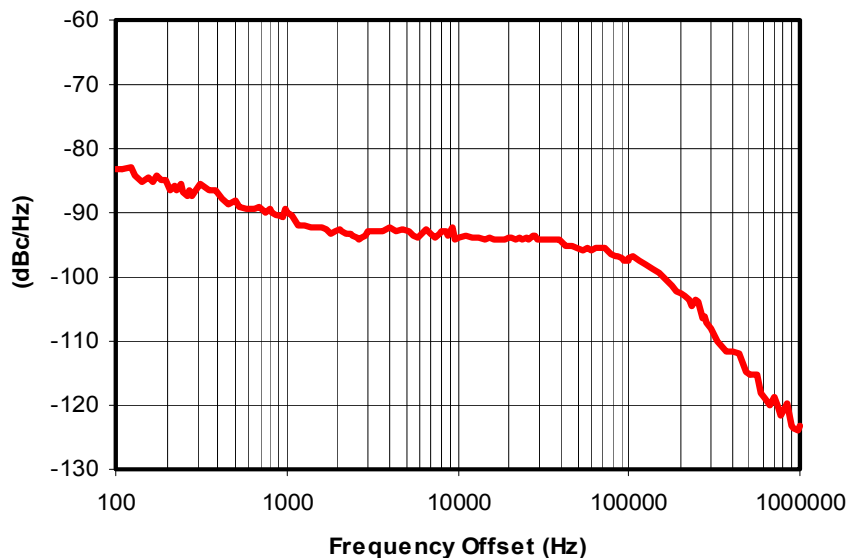

**Frequency = 1300 MHz**  
**Reference = 10 MHz**  
**Loop Band Width = 100 kHz**  
**Comparison Frequency = 1.25 MHz**

## Functional Description

The PE3240 consists of a prescaler, counters, a phase detector and control logic. The dual modulus prescaler divides the VCO frequency by either 10 or 11, depending on the value of the modulus select. Counters “R” and “M” divide the reference and prescaler output, respectively, by integer values stored in a 20-bit register. An additional counter (“A”) is used in the modulus select logic.

The phase-frequency detector generates up and down frequency control signals. Data is written into the internal registers via the three wire serial bus. There are also various operational and test modes and a lock detect output.

Figure 6. Functional Block Diagram

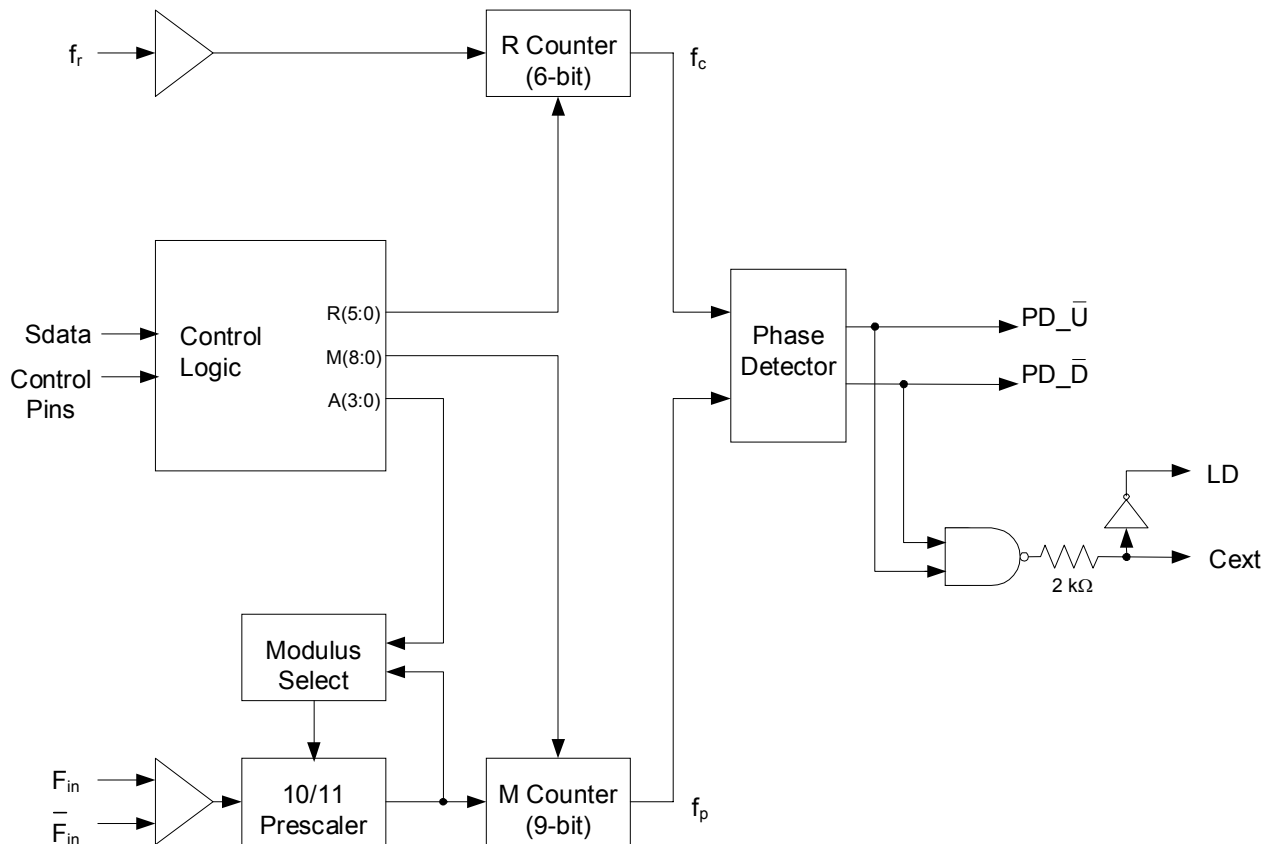

## Main Counter Chain

### Normal Operating Mode

Setting the Pre\_en control bit “low” enables the  $\div 10/11$  prescaler. The main counter chain then divides the RF input frequency ( $F_{in}$ ) by an integer derived from the values in the “M” and “A” counters.

In this mode, the output from the main counter chain ( $f_p$ ) is related to the VCO frequency ( $F_{in}$ ) by the following equation:

$$f_p = F_{in} / [10 \times (M + 1) + A] \quad (1)$$

where  $A \leq M + 1$ ,  $1 \leq M \leq 511$

When the loop is locked,  $F_{in}$  is related to the reference frequency ( $f_r$ ) by the following equation:

$$F_{in} = [10 \times (M + 1) + A] \times (f_r / (R+1)) \quad (2)$$

where  $A \leq M + 1$ ,  $1 \leq M \leq 511$

A consequence of the upper limit on A is that  $F_{in}$  must be greater than or equal to  $90 \times (f_r / (R+1))$  to obtain contiguous channels. The A counter can accept values as high as 15, but in typical operation it will cycle from 0 to 9 between increments in M.

Programming the M counter with the minimum allowed value of “1” will result in a minimum M counter divide ratio of “2”.

### Prescaler Bypass Mode

Setting the frequency control register bit Pre\_en “high” allows  $F_{in}$  to bypass the  $\div 10/11$  prescaler. In this mode, the prescaler and A counter are powered down, and the input VCO frequency is divided by the M counter directly. The following equation relates  $F_{in}$  to the reference frequency  $f_r$ :

$$F_{in} = (M + 1) \times (f_r / (R+1)) \quad (3)$$

where  $1 \leq M \leq 511$

## Reference Counter

The reference counter chain divides the reference frequency  $f_r$  down to the phase detector comparison frequency  $f_c$ .

The output frequency of the 6-bit R Counter is related to the reference frequency by the following equation:

$$f_c = f_r / (R + 1) \quad (4)$$

where  $0 \leq R \leq 63$

Note that programming R with “0” will pass the reference frequency ( $f_r$ ) directly to the phase detector.

## Register Programming

### Serial Interface Mode

While the E\_WR input is “low” and the S\_WR input is “low”, serial input data (Sdata input),  $B_0$  to  $B_{19}$ , are clocked serially into the primary register on the rising edge of Sclk, MSB ( $B_0$ ) first. The contents from the primary register are transferred into the secondary register on the rising edge of either S\_WR according to the timing diagrams shown in Figure 7. Data are transferred to the counters as shown in Table 7 on page 9.

The double buffering provided by the primary and secondary registers allows for “ping-pong” counter control using the FSELS input. When FSELS is “high”, the primary register contents set the counter inputs. When FSELS is “low”, the secondary register contents are utilized.

While the E\_WR input is “high” and the S\_WR input is “low”, serial input data (Sdata input),  $B_0$  to  $B_7$ , are clocked serially into the enhancement register on the rising edge of Sclk, MSB ( $B_0$ ) first. The enhancement register is double buffered to prevent inadvertent control changes during serial loading, with buffer capture of the serially entered data performed on the falling edge of E\_WR according to the timing diagram shown in Figure 7. After the falling edge of E\_WR, the data provide control bits as shown in Table 8 on page 9 will have their bit functionality enabled by asserting the Enh input “low”.



**Table 7. Primary Register Programming**

Interface Mode	$\overline{\text{Enh}}$	R <sub>5</sub>	R <sub>4</sub>	M <sub>8</sub>	M <sub>7</sub>	$\overline{\text{Pre\_en}}$	M <sub>6</sub>	M <sub>5</sub>	M <sub>4</sub>	M <sub>3</sub>	M <sub>2</sub>	M <sub>1</sub>	M <sub>0</sub>	R <sub>3</sub>	R <sub>2</sub>	R <sub>1</sub>	R <sub>0</sub>	A <sub>3</sub>	A <sub>2</sub>	A <sub>1</sub>	A <sub>0</sub>
Serial*	1	B <sub>0</sub>	B <sub>1</sub>	B <sub>2</sub>	B <sub>3</sub>	B <sub>4</sub>	B <sub>5</sub>	B <sub>6</sub>	B <sub>7</sub>	B <sub>8</sub>	B <sub>9</sub>	B <sub>10</sub>	B <sub>11</sub>	B <sub>12</sub>	B <sub>13</sub>	B <sub>14</sub>	B <sub>15</sub>	B <sub>16</sub>	B <sub>17</sub>	B <sub>18</sub>	B <sub>19</sub>

\*Serial data clocked serially on Sclk rising edge while E\_WR “low” and captured in secondary register on S\_WR rising edge.



**Table 8. Enhancement Register Programming**

Interface Mode	$\overline{\text{Enh}}$	Reserved	Reserved	f <sub>p</sub> Output	Power down	Counter load	MSEL output	f <sub>c</sub> output	Reserved
Serial*	0	B <sub>0</sub>	B <sub>1</sub>	B <sub>2</sub>	B <sub>3</sub>	B <sub>4</sub>	B <sub>5</sub>	B <sub>6</sub>	B <sub>7</sub>

\*Serial data clocked serially on Sclk rising edge while E\_WR “high” and captured in the double buffer on E\_WR falling edge.



**Figure 7. Serial Interface Mode Timing Diagram**

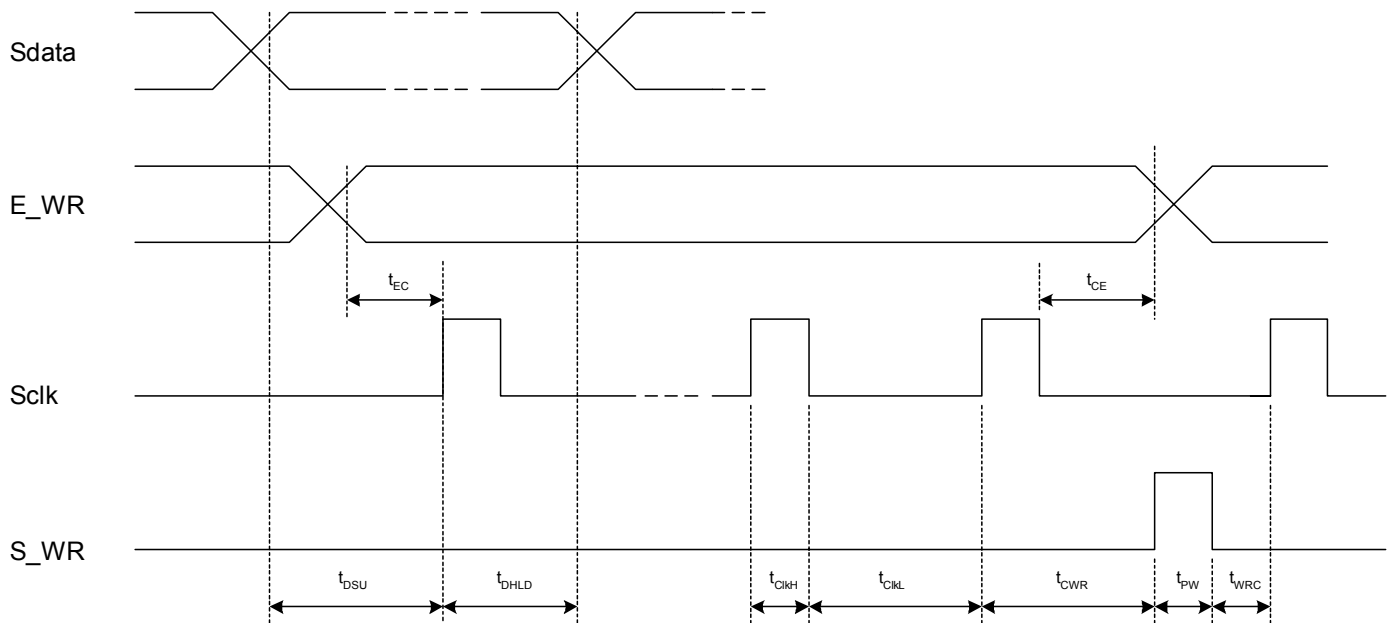

## Enhancement Register

The functions of the enhancement register bits are shown below with all bits active “high”.

**Table 9. Enhancement Register Bit Functionality**

Bit Function		Description
Bit 0	Reserved**	
Bit 1	Reserved**	
Bit 2	$f_p$ output	Drives the M counter output onto the Dout output.
Bit 3	Power down	Power down of all functions except programming interface.
Bit 4	Counter load	Immediate and continuous load of counter programming.
Bit 5	MSEL output	Drives the internal dual modulus prescaler modulus select (MSEL) onto the Dout output.
Bit 6	$f_c$ output	Drives the reference counter output onto the Dout output
Bit 7	Reserved**	

\*\* Program to 0

## Phase Detector

The phase detector is triggered by rising edges from the main Counter ( $f_p$ ) and the reference counter ( $f_c$ ). It has two outputs, namely PD\_U, and PD\_D. If the divided VCO leads the divided reference in phase or frequency ( $f_p$  leads  $f_c$ ), PD\_D pulses “low”. If the divided reference leads the divided VCO in phase or frequency ( $f_c$  leads  $f_p$ ), PD\_U pulses “low”. The width of either pulse is directly proportional to phase offset between the two input signals,  $f_p$  and  $f_c$ .

The phase detector gain is equal to  $2.70 \text{ V} / 2 \pi$ , which numerically yields  $0.43 \text{ V} / \text{Radian}$ .

PD\_U and PD\_D drive an active loop filter which controls the VCO tune voltage. PD\_U pulses result in an increase in VCO frequency and PD\_D results in a decrease in VCO frequency, for a positive  $K_v$  VCO.

A lock detect output, LD is also provided, via the pin Cext. Cext is the logical “NAND” of PD\_U and PD\_D waveforms, which is driven through a series 2 kohm resistor. Connecting Cext to an external shunt capacitor provides low pass filtering of this signal. Cext also drives the input of an internal inverting comparator with an open drain output. Thus LD is an “AND” function of PD\_U and PD\_D

**Figure 9. Package Drawing**

20-lead TSSOP

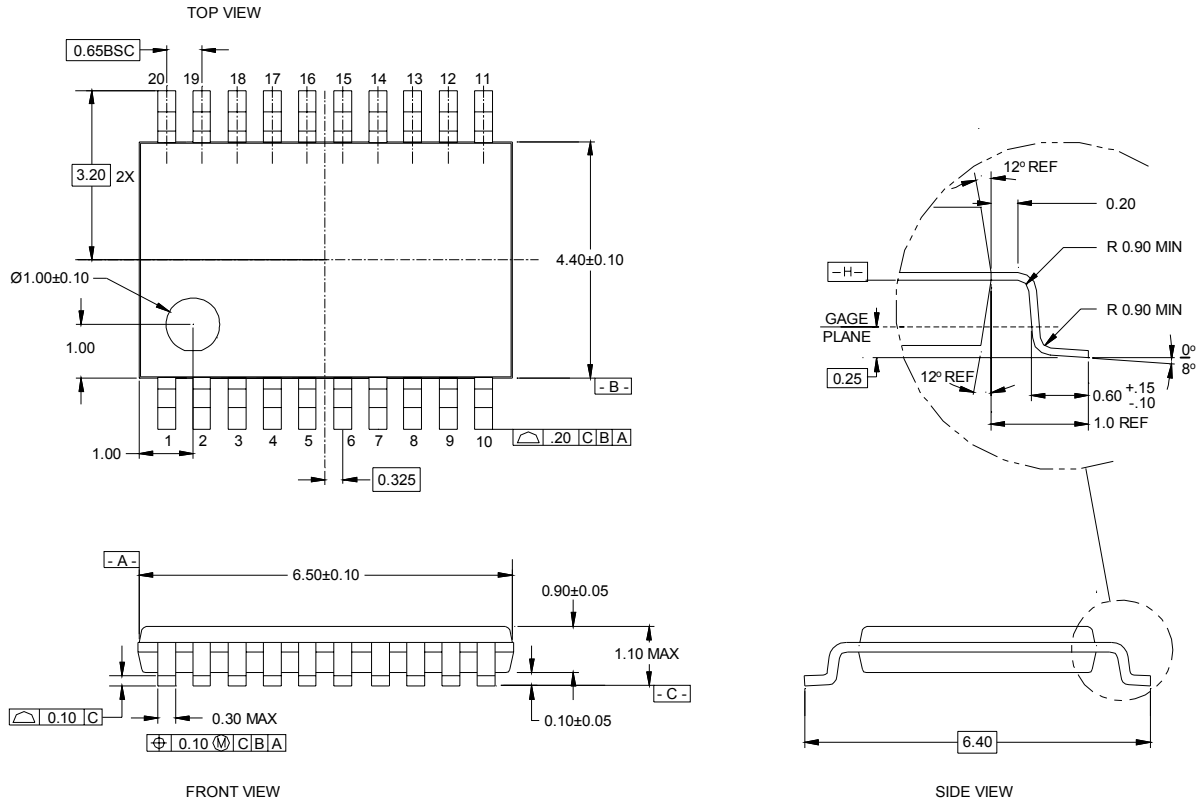

**Table 10. Ordering Information**

Order Code	Part Marking	Description	Package	Shipping Method
3240-11	PE3240	PE3240-20TSSOP-74A	20-lead TSSOP	74 units / Tube
3240-12	PE3240	PE3240-20TSSOP-2000C	20-lead TSSOP	2000 units / T&R
3240-00	PE3240EK	PE3240-20TSSOP-EVAL KIT	Evaluation Board	1 / Box

## Sales Offices

### *The Americas*

#### **Peregrine Semiconductor Corporation**

9450 Carroll Park Drive  
San Diego, CA 92121  
Tel 858-731-9400  
Fax 858-731-9499

### *Europe*

#### **Peregrine Semiconductor Europe**

Bâtiment Maine  
13-15 rue des Quatre Vents  
F-92380 Garches, France  
Tel: +33-1-47-41-91-73  
Fax : +33-1-47-41-91-73

#### **Space and Defense Products**

##### **Americas:**

Tel: 505-881-0438  
Fax: 505-881-0443

##### **Europe, Asia Pacific:**

180 Rue Jean de Guiramand  
13852 Aix-En-Provence cedex 3, France  
Tel: +33(0) 4 4239 3361  
Fax: +33(0) 4 4239 7227

### *North Asia Pacific*

#### **Peregrine Semiconductor K.K.**

5A-5, 5F Imperial Tower  
1-1-1 Uchisaiwaicho, Chiyoda-ku  
Tokyo 100-0011 Japan  
Tel: +81-3-3502-5211  
Fax: +81-3-3502-5213

#### **Peregrine Semiconductor, Korea**

#B-2402, Kolon Tripolis, #210  
Geumgok-dong, Bundang-gu, Seongnam-si  
Gyeonggi-do, 463-480 S. Korea  
Tel: +82-31-728-4300  
Fax: +82-31-728-4305

### *South Asia Pacific*

#### **Peregrine Semiconductor, China**

Shanghai, 200040, P.R. China  
Tel: +86-21-5836-8276  
Fax: +86-21-5836-7652

For a list of representatives in your area, please refer to our Web site at: [www.psemi.com](http://www.psemi.com)

## Data Sheet Identification

### **Advance Information**

The product is in a formative or design stage. The data sheet contains design target specifications for product development. Specifications and features may change in any manner without notice.

### **Preliminary Specification**

The data sheet contains preliminary data. Additional data may be added at a later date. Peregrine reserves the right to change specifications at any time without notice in order to supply the best possible product.

### **Product Specification**

The data sheet contains final data. In the event Peregrine decides to change the specifications, Peregrine will notify customers of the intended changes by issuing a DCN (Document Change Notice).

The information in this data sheet is believed to be reliable. However, Peregrine assumes no liability for the use of this information. Use shall be entirely at the user's own risk.

No patent rights or licenses to any circuits described in this data sheet are implied or granted to any third party.

Peregrine's products are not designed or intended for use in devices or systems intended for surgical implant, or in other applications intended to support or sustain life, or in any application in which the failure of the Peregrine product could create a situation in which personal injury or death might occur. Peregrine assumes no liability for damages, including consequential or incidental damages, arising out of the use of its products in such applications.

The Peregrine name, logo, and UTSi are registered trademarks and UltraCMOS and HaRP are trademarks of Peregrine Semiconductor Corp.