

Typical Applications

- 3V CDMA/AMPS Cellular Handsets
- 3V CDMA2000/1X Cellular Handsets
- Compatible with Qualcomm Chipset
- Spread-Spectrum Systems

Product Description

The RF3117 is a high-power, high-efficiency linear amplifier module targeting 3V handheld systems. The device is manufactured on an advanced Gallium Arsenide Heterojunction Bipolar Transistor (HBT) process, and has been designed for use as the final RF amplifier in dual-mode 3V CDMA/AMPS handheld digital cellular equipment, spread-spectrum systems, and other applications in the 824MHz to 849MHz band. The RF3117 has a digital control line for low power application to reduce the current drain. The device is self-contained with 50Ω input and output that is matched to obtain optimum power, efficiency, and linearity characteristics. The module is an ultra-small 6mmx6mm land grid array with backside ground.

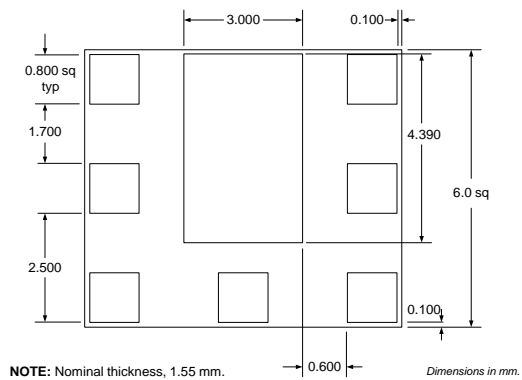

Optimum Technology Matching® Applied

- Si BJT
- GaAs HBT
- GaAs MESFET
- Si Bi-CMOS
- SiGe HBT
- Si CMOS

Package Style: LGM (6mmx6mm)

Features

- Input/Output Internally Matched @ 50Ω
- Single 3V Supply
- 30dBm Linear Output Power
- 30dB Linear Gain
- 33% Linear Efficiency
- 55mA Idle Current

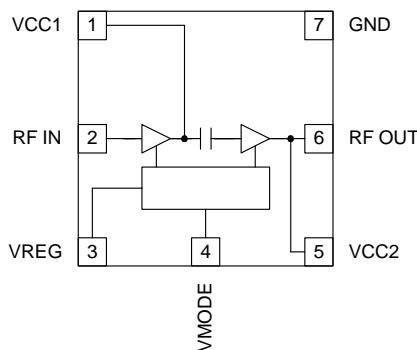

Functional Block Diagram

Ordering Information

- RF3117 3V 900MHz Linear Amplifier Module
- RF3117 PCBA Fully Assembled Evaluation Board

RF Micro Devices, Inc.
7628 Thorndike Road
Greensboro, NC 27409, USA

Tel (336) 664 1233
Fax (336) 664 0454
<http://www.rfmd.com>

Absolute Maximum Ratings

Parameter	Rating	Unit
Supply Voltage (RF off)	+8.0	V _{DC}
Supply Voltage (P _{OUT} ≤31dBm)	+5.2	V _{DC}
Control Voltage (V _{REG})	+4.2	V _{DC}
Input RF Power	+10	dBm
Mode Voltage (V _{MODE})	+3.5	V _{DC}
Operating Case Temperature	-30 to +110	°C
Storage Temperature	-30 to +150	°C



Caution! ESD sensitive device.

RF Micro Devices believes the furnished information is correct and accurate at the time of this printing. However, RF Micro Devices reserves the right to make changes to its products without notice. RF Micro Devices does not assume responsibility for the use of the described product(s).

Parameter	Specification			Unit	Condition
	Min.	Typ.	Max.		
High Power State (V _{MODE} Low)					Typical Performance at V _{CC} =3.2V, V _{REG} =3V, T _{AMB} =25°C, Frequency=824MHz to 849MHz (unless otherwise specified)
Frequency Range	824		849	MHz	
Linear Gain	27	30		dB	
Second Harmonic		-35		dBc	
Third Harmonic		-40		dBc	
Maximum Linear Output Power (CDMA Modulation)	29	30		dBm	
Total Linear Efficiency		33		%	V _{CC} =3.2V, P _{OUT} =29dBm (room temperature)
Adjacent Channel Power Rejection		-46.5	-45.0	dBc	ACPR @ 885kHz, P _{OUT} =Max P _{OUT}
		-59	-57	dBc	ACPR @ 1980kHz, P _{OUT} =Max P _{OUT}
Input VSWR		1.8:1			
Output VSWR			10:1		No damage.
Noise Power		-135		dBm/Hz	No oscillations. > -70dBc At 45MHz offset.
Low Power State (V _{MODE} High)					Typical Performance at V _{CC} =3.2V, V _{REG} =3V, T _{AMB} =25°C, Frequency=824MHz to 849MHz (unless otherwise specified)
Frequency Range	824		849	MHz	
Linear Gain	17.5	21		dB	
Second Harmonic		-35		dBc	
Third Harmonic		-40		dBc	
Maximum Linear Output Power (CDMA Modulation)	16	20		dBm	
Adjacent Channel Power Rejection		-52	-44	dBc	ACPR @ 885kHz, P _{OUT} =Max P _{OUT}
		-62	-55	dBc	ACPR @ 1980kHz, P _{OUT} =Max P _{OUT}
Output VSWR			10:1		No damage.
			6:1		No oscillations. > -70dBc

Parameter	Specification			Unit	Condition
	Min.	Typ.	Max.		
FM Mode					Typical Performance at $V_{CC}=3.2V$, $V_{REG}=3V$, $T_{AMB}=25^{\circ}C$, Frequency=824MHz to 849MHz (unless otherwise specified)
Frequency Range	824		849	MHz	
Gain		30		dB	
Second Harmonic		-32		dBc	
Third Harmonic		-40		dBc	
Max CW Output Power	31.5			dBm	
Total Efficiency (AMPS mode)		42		%	$P_{OUT}=31.5dBm$ (room temperature)
Input VSWR			<2:1		
Output VSWR			10:1		No damage.
			6:1		No oscillations. > -70dBc
DC Supply					$T_{AMB}=25^{\circ}C$
Supply Voltage Range	3.2	3.7	4.2	V	
Quiescent Current		160	240	mA	$V_{MODE}=Low$, $V_{REG}=3V$, $V_{CC}=3.2V$
		55	65	mA	$V_{MODE}=High$, $V_{REG}=3V$, $V_{CC}=3.2V$
V_{REG} Current			10	mA	$V_{MODE}=High$
V_{MODE} Current			1	mA	
Turn On/Off Time			<40	μs	V_{REG} switch from Low to High, I_{CC} to within 90% of the final value, P_{OUT} within 1 dB of the final value
Total Current (Power Down)		3	10	μA	$V_{REG}=Low$, $V_{MODE}=Low$
V_{REG} "Low" Voltage	0		0.5	V	
V_{REG} "High" Voltage	2.9	3.0	3.1	V	
V_{MODE} "Low" Voltage	0		0.5	V	
V_{MODE} "High" Voltage	2.0		3.0	V	

Pin	Function	Description	Interface Schematic
1	VCC1	First stage collector supply. A low frequency decoupling capacitor (e.g., 4.7 μ F) is required.	
2	RF IN	RF input internally matched to 50 Ω . This input is internally AC-coupled.	
3	VREG	Regulated voltage supply for amplifier bias. In Power Down mode, both V_{REG} and V_{MODE} need to be LOW (<0.5V).	
4	VMODE	For nominal operation (High Power Mode), V_{MODE} is set LOW. When set HIGH, devices are turned off to improve efficiency.	
5	VCC2	Output stage collector supply. A low frequency decoupling capacitor (e.g., 4.7 μ F) is required.	
6	RF OUT	RF output internally matched to 50 Ω . This output is internally AC-coupled.	
7	GND	Ground connection. Connect to package base ground. For best performance, keep traces physically short and connect immediately to ground plane.	
Pkg Base	GND	Ground connection. The backside of the package should be soldered to a top side ground pad which is connected to the ground plane with multiple vias. The pad should have a short thermal path to the ground plane.	

Evaluation Board Schematic

(Download [Bill of Materials](http://www.rfmd.com) from www.rfmd.com.)

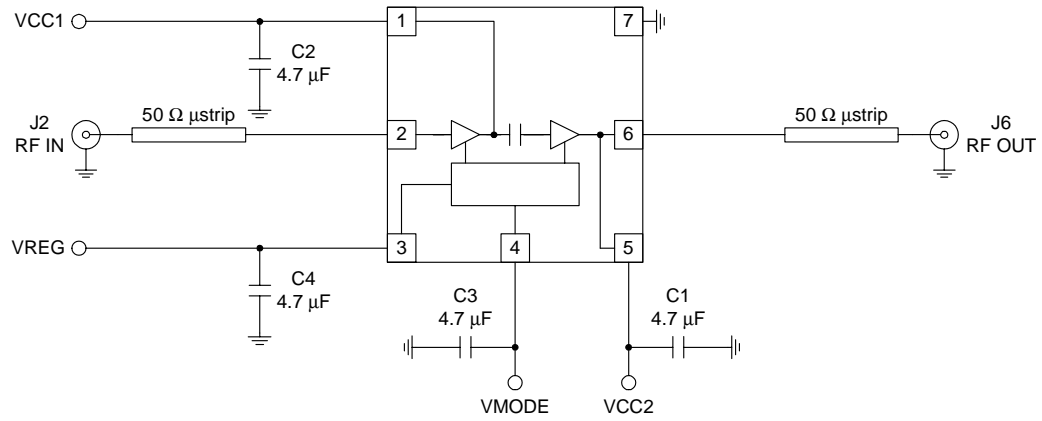

Evaluation Board Layout
Board Size 1.5" x 1.5"

Board Thickness 0.032", Board Material FR-4, Multi-Layer, Ground Plane at 0.014"

2

POWER AMPLIFIERS

