

18.0-30.0 GHz GaAs Receiver QFN, 7x7 mm

Mimix
BROADBAND™

XR1002-QB
RoHS

July 2008 - Rev 10-Jul-08

Features

- ✕ Fundamental High Dynamic Range Receiver
- ✕ Integrated Gain Control
- ✕ +4.0 dBm Input Third Order Intercept (IIP3)
- ✕ 14.0 dB Conversion Gain
- ✕ 3.5 dB Noise Figure
- ✕ 25.0 dB Image Rejection

General Description

Mimix Broadband's 18.0-30.0 GHz GaAs MMIC receiver has a 12.0 dB gain control range, a noise figure of 3.5 dB and 25.0 dB image rejection across the band. This device is a three stage LNA followed by a single transistor "Tee" attenuator and an image reject fundamental resistive HEMT mixer. At high signal levels the radio AGC system can be used to reduce the receiver gain improving the IIP3 providing for minimum distortion at modulation schemes as high as 256 QAM (ETSI-see Technical Note 1). The image reject mixer eliminates the need for a bandpass filter after the LNA to remove thermal noise at the image frequency. I and Q mixer outputs are provided and an external 90 degree hybrid is required to select the desired sideband. This MMIC uses Mimix Broadband's GaAs PHEMT device model technology, and is based upon electron beam lithography to ensure high repeatability and uniformity. The chip has surface passivation to protect and provide a rugged part with backside via holes and gold metallization to allow either a conductive epoxy or eutectic solder die attach process. This device is well suited for Millimeter-wave Point-to-Point Radio, LMDS, SATCOM and VSAT applications.



Absolute Maximum Ratings

Supply Voltage (Vd)	+6.0 VDC
Supply Current (Id)	300 mA
Gate Bias Voltage (Vg)	+0.3 VDC
Input Power (RF Pin)	0.0 dBm
Storage Temperature (Tstg)	-65 to +165 °C
Operating Temperature (Ta)	-55 to MTTF Table ³
Channel Temperature (Tch)	MTTF Table ³
Moisture Sensitivity Level	MSL3

(1) Measured using constant current, 10dB attenuation and -20dBm total input power.

(2) At minimum attenuation.

(3) Channel temperature affects a device's MTTF. It is recommended to keep channel temperature as low as possible for maximum life.

Electrical Characteristics (Ambient Temperature T = 25° C)

Parameter	Units	Min.	Typ.	Max.
Frequency Range (RF) Upper Side Band	GHz	18.0	-	30.0
Frequency Range (LO)	GHz	14.0	-	34.0
Frequency Range (IF)	GHz	DC	-	4.0
Input Return Loss RF (S11)	dB	-	10.0	-
Small Signal Conversion Gain RF/IF (S21)	dB	-	14.0	-
Attenuation	dB	0.0	-	12.0
LO Input Drive (P _{LO})	dBm	+12.0	+15.0	+18.0
Image Rejection	dBc	15.0	25.0	-
Noise Figure (NF)	dB	-	3.5	-
Isolation LO/RF	dB	-	40.0	-
Input Third Order Intercept (IIP3)	dBm	-	+4.0	-
Drain Bias Voltage (Vd1,2)	VDC	-	+4.5	+5.5
Gate Bias Voltage (Vg1,2) (Vg4=-0.8V)	VDC	-1.0	-0.5	0.0
Control Bias Voltage (Vg3)	VDC	-1.5	-1.2	0.0
Supply Current (Id) (Vd=4.5V, Vg=-0.5V Typical)	mA	-	135	270

Mimix Broadband, Inc., 10795 Rockley Rd., Houston, Texas 77099
Tel: 281.988.4600 Fax: 281.988.4615 mimixbroadband.com

Page 1 of 10

Characteristic Data and Specifications are subject to change without notice. ©2008 Mimix Broadband, Inc.
Export of this item may require appropriate export licensing from the U.S. Government. In purchasing these parts, U.S. Domestic customers accept their obligation to be compliant with U.S. Export Laws.

18.0-30.0 GHz GaAs Receiver QFN, 7x7 mm

July 2008 - Rev 10-Jul-08

Receiver Measurements

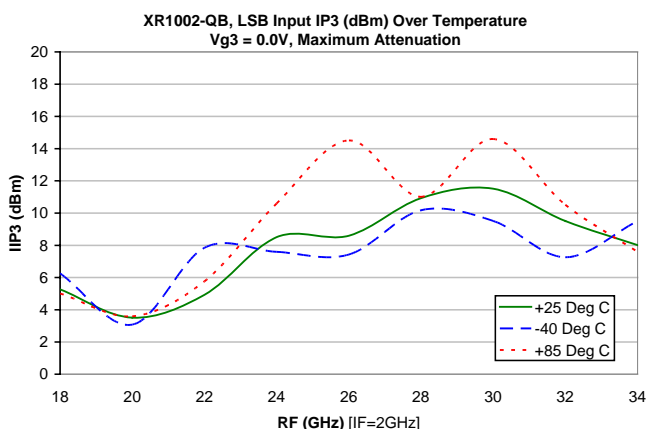
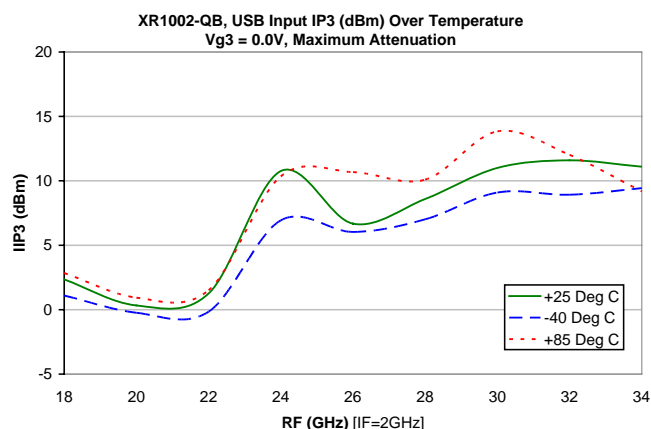
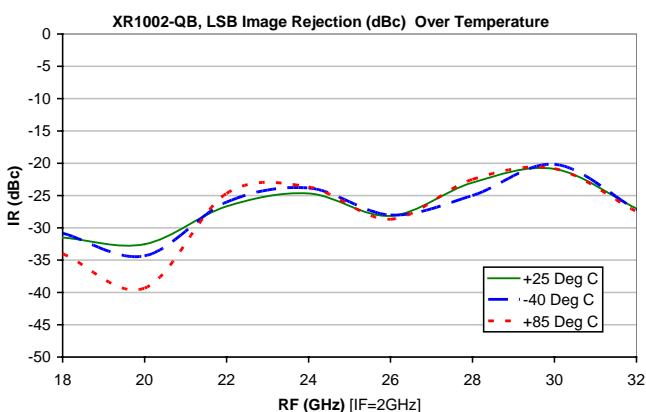
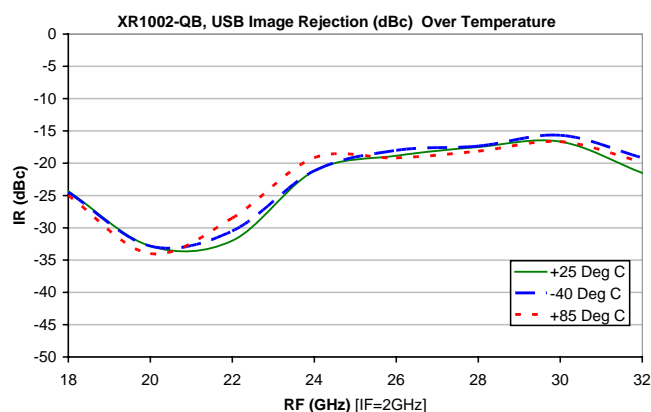
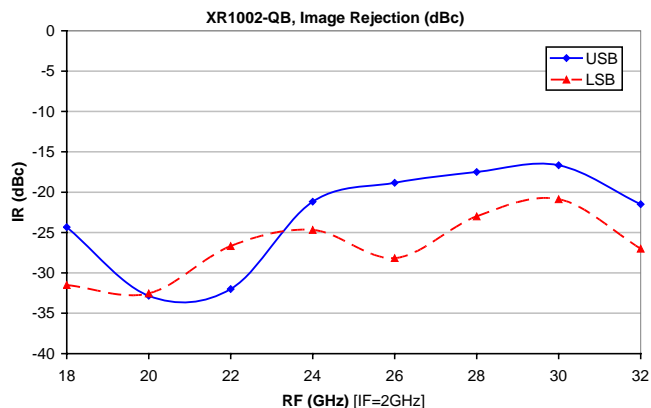
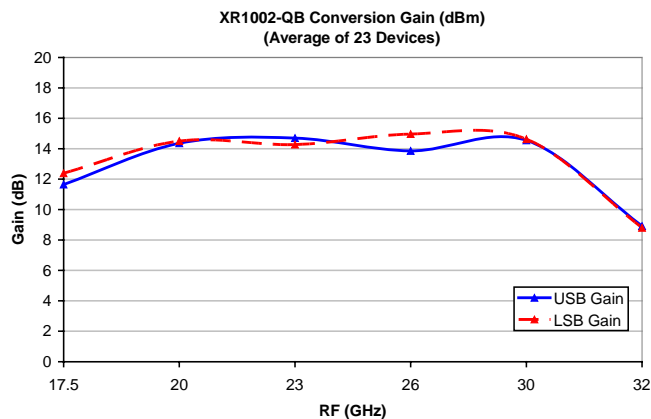

18.0-30.0 GHz GaAs Receiver QFN, 7x7 mm

July 2008 - Rev 10-Jul-08

Receiver Measurements (cont.)

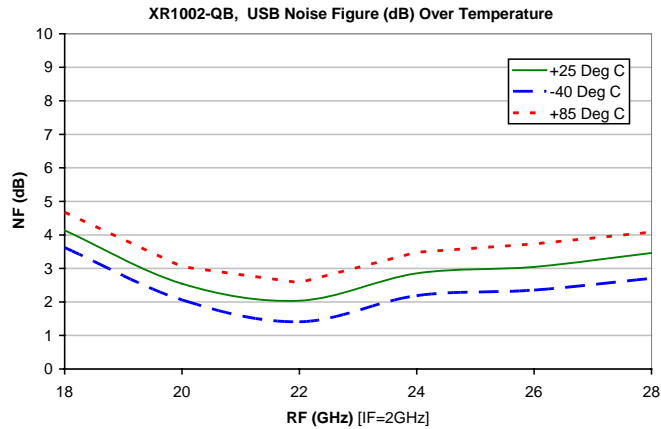

18.0-30.0 GHz GaAs Receiver

QFN, 7x7 mm

July 2008 - Rev 10-Jul-08

Physical Dimensions

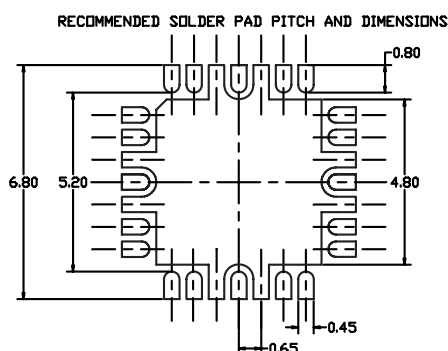
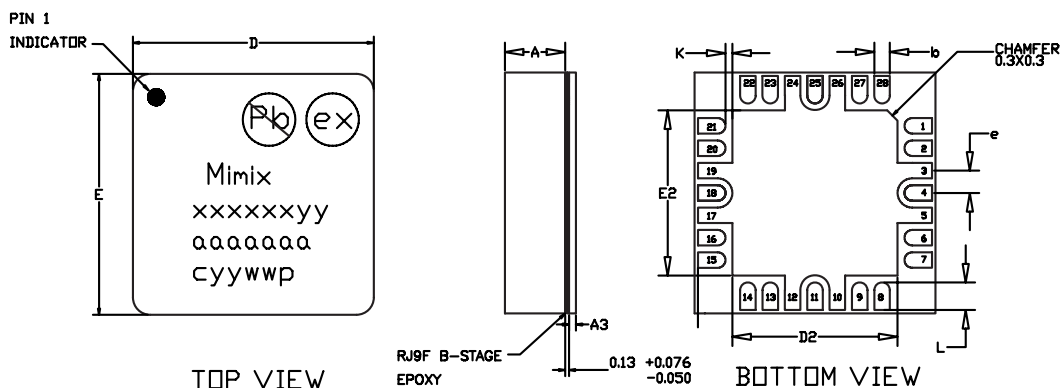

Note:

1. ALL DIMENSIONS ARE IN mm.

	MIN	TYP	MAX
A	1.70	1.75	1.80
A3	0.20 REF		
b	0.40	0.45	0.50
K	0.41	-	-
D	7.00 BSC		
E	7.00 BSC		
e	0.65		
D2	4.75	4.80	4.85
E2	4.35	4.40	4.45
L	0.75	0.80	0.85

(Note: Engineering designator is 30KRP_03A)

Pin Designations

Pin Number	Pin Name	Pin Function	Nominal Value	Unit
3	GND	Ground		
4	RF IN	RF Input		
5	GND	Ground		
8	VG1&2	Gate Bias Voltage	-0.5	Volt
9	VG3	Control Bias Voltage	-1.2	Volt
10	GND	Ground		
11	IF2Out	IF2 Output		
12	GND	Ground		
17	GND	Ground		
18	LO IN	LO Input		
19	GND	Ground		
23	VG4	Gate Bias Voltage	-0.8	Volt
24	GND	Ground		
25	IF1Out	IF1 Output		
26	GND	Ground		
27	VD1&2	Drain Bias Voltage	4.5	Volt
All Other Pins	NC	Not Connected		

18.0-30.0 GHz GaAs Receiver QFN, 7x7 mm

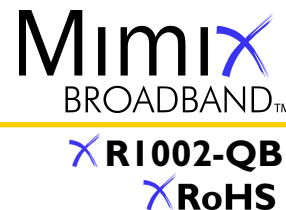

July 2008 - Rev 10-Jul-08

App Note [1] Biasing - This device is operated with both stages in parallel, and can be biased for low noise performance or high power performance. Low noise bias is nominally $V_d=4.5V, I_d=135mA$ and is the recommended bias condition. More controlled performance will be obtained by separately biasing V_{d1} and V_{d2} each at 4.5V, 65mA. Power bias may be as high as $V_d=5.5V, I_d=270mA$ with all stages in parallel, or most controlled performance will be obtained by separately biasing V_{d1} and V_{d2} each at 5.5V, 135mA. Attenuator bias, V_{g3} , can be adjusted from 0.0 to -1.2V with 0.0V providing maximum attenuation and -1.2V providing minimum attenuation. Image reject mixer bias, V_{g4} , should nominally be -0.8V to minimize sensitivity of mixer performance to LO level. It is also recommended to use active biasing to keep the currents constant as the RF power and temperature vary; this gives the most reproducible results. Depending on the supply voltage available and the power dissipation constraints, the bias circuit may be a single transistor or a low power operational amplifier, with a low value resistor in series with the drain supply used to sense the current. The gate of the pHEMT is controlled to maintain correct drain current and thus drain voltage. The typical gate voltage needed to do this is -0.5V. Typically the gate is protected with Silicon diodes to limit the applied voltage. Also, make sure to sequence the applied voltage to ensure negative gate bias is available before applying the positive drain supply.

MTTF Tables

These numbers were calculated based on accelerated life test information and thermal model analysis received from the fabricating foundry.

Backplate Temperature	Channel Temperature	Rth	MTTF Hours	FITs
55 deg Celsius	81 deg Celsius	-	6.77E+11	1.48E-03
75 deg Celsius	101 deg Celsius	65.0° C/W	4.09E+10	2.44E-02
95 deg Celsius	121 deg Celsius	-	3.29E+09	3.04E-01

Bias Conditions: $V_d=3.0V, I_d=135\text{ mA}$

Backplate Temperature	Channel Temperature	Rth	MTTF Hours	FITs
55 deg Celsius	142 deg Celsius	-	4.11E+08	2.43E+00
75 deg Celsius	162 deg Celsius	58.9° C/W	5.36E+07	1.87E+01
95 deg Celsius	182 deg Celsius	-	8.35E+06	1.20E+02

Bias Conditions: $V_d=5.5V, I_d=270\text{ mA}$

18.0-30.0 GHz GaAs Receiver QFN, 7x7 mm

App Note [3] USB/LSB Selection -

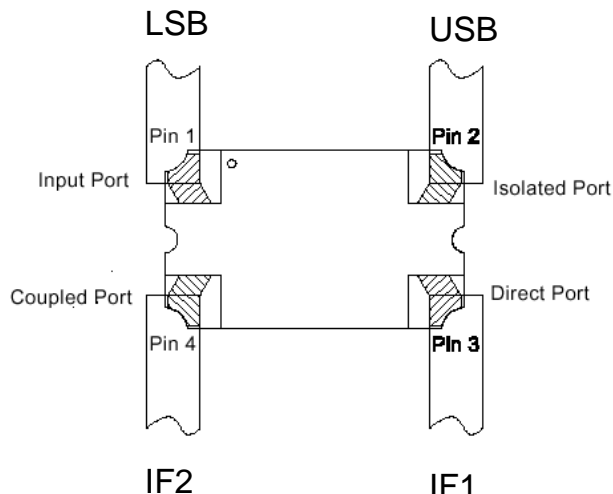

For Upper Side Band operation (USB):

With IF1 and IF2 connected to the direct port (0°) and coupled port (90°) respectively as shown in the diagram, the USB signal will reside on the isolated port. The input port must be loaded with 50 ohms.

For Lower Side Band operation (LSB):

With IF1 and IF2 connected to the direct port (0°) and coupled port (90°) respectively as shown in the diagram, the LSB signal will reside on the input port. The isolated port must be loaded with 50 ohms.

An alternate method of Selection of USB or LSB:

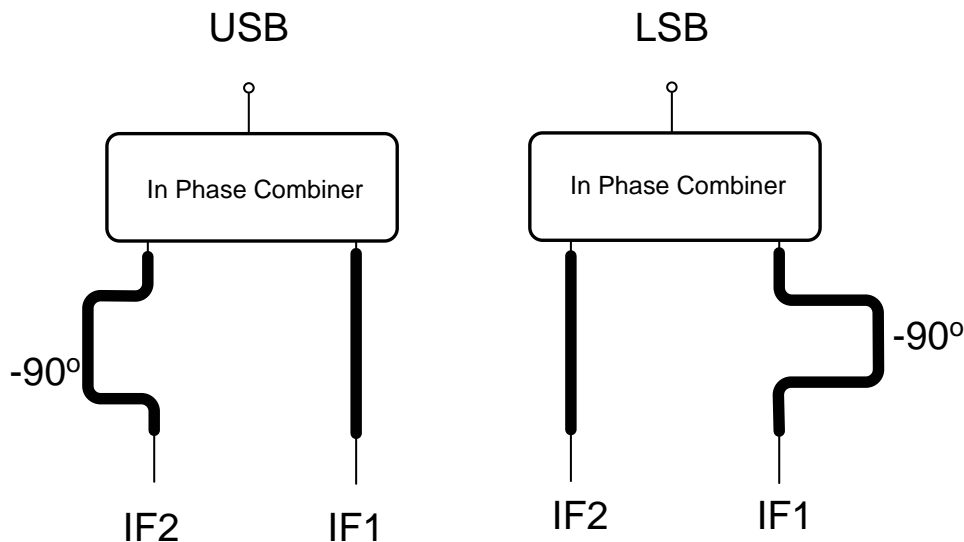

18.0-30.0 GHz GaAs Receiver QFN, 7x7 mm

July 2008 - Rev 10-Jul-08

Application Circuit

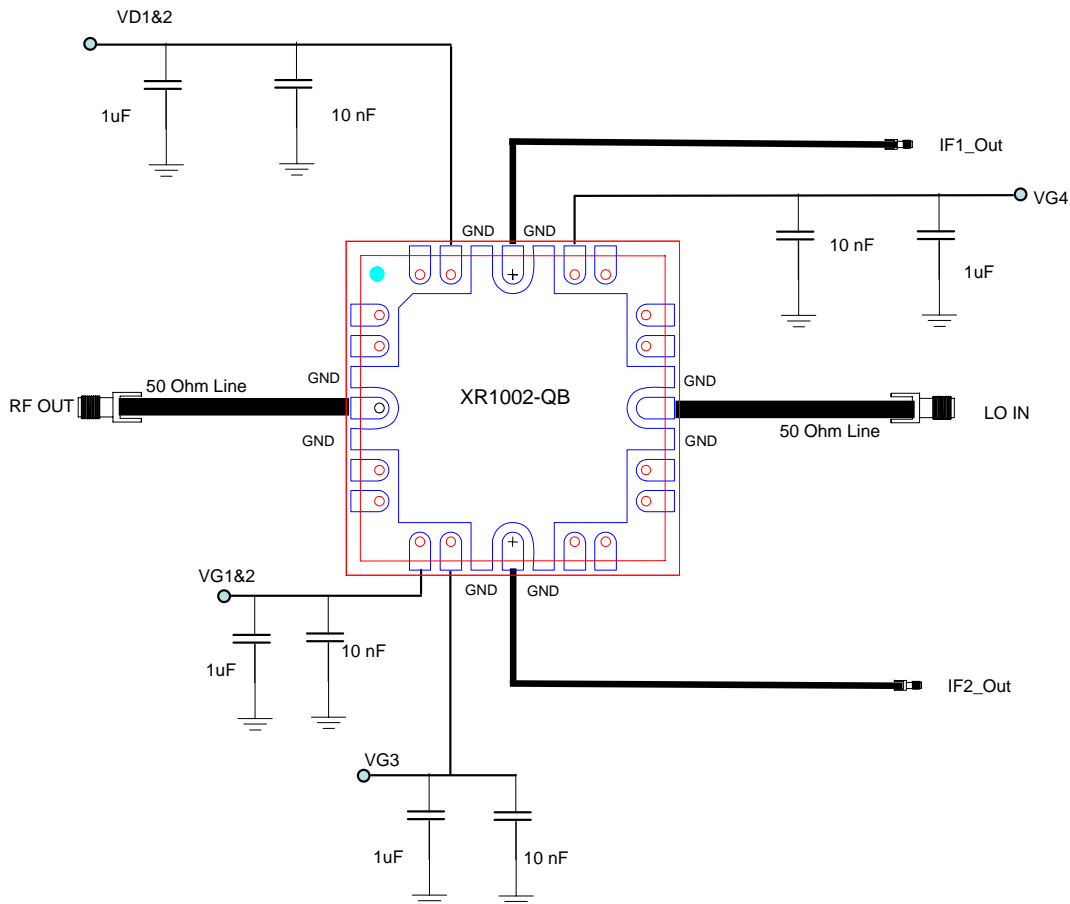

Board Layout

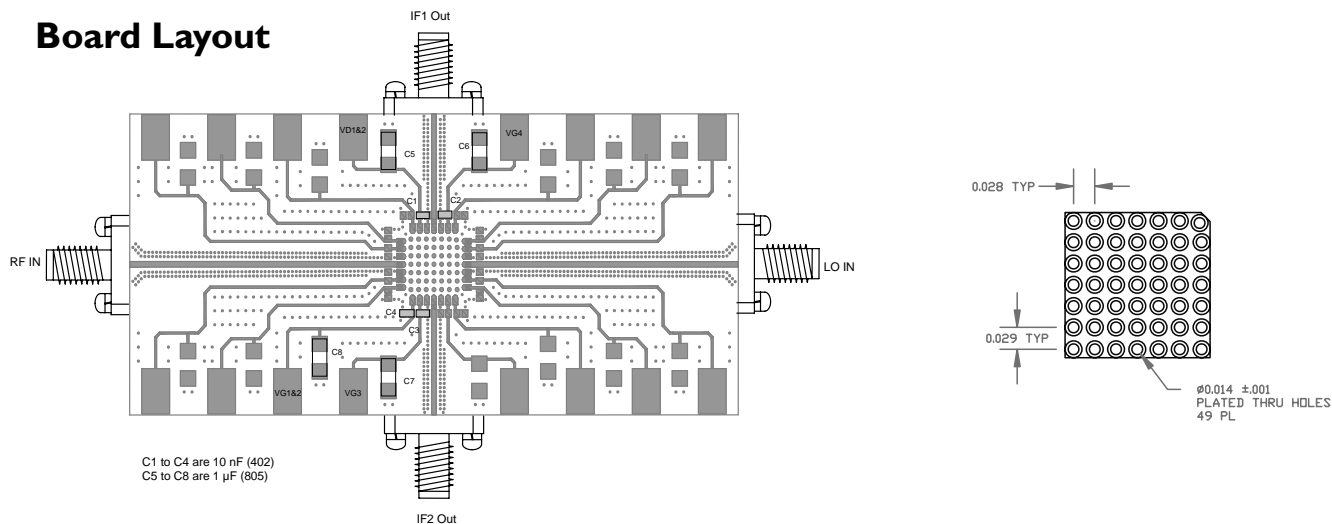

18.0-30.0 GHz GaAs Receiver QFN, 7x7 mm

July 2008 - Rev 10-Jul-08

Typical Application

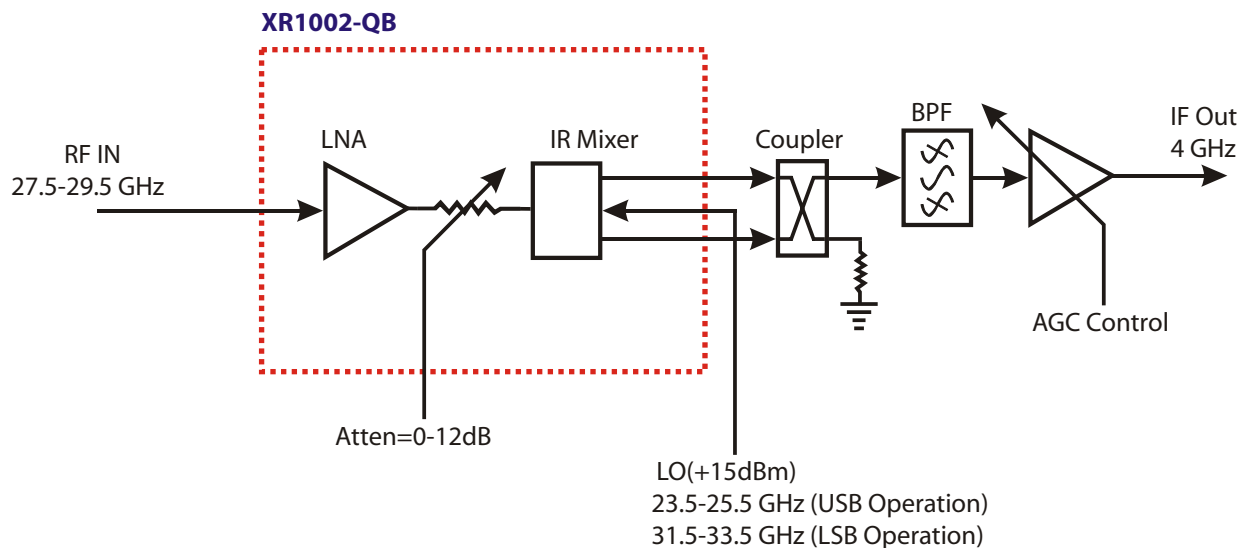

Mimix Broadband MMIC-based 18.0-30.0 GHz Receiver Block Diagram

(Changing LO and IF frequencies as required allows design to operate as high as 30 GHz)

Also See: Multiplier selection guide at www.mimixbroadband.com for multipliers that can be used to drive the XR1002.

Factory Automation and Identification

Mimix Designator	Package Type	Number of leads offered	W Tape Width	P ₁ Component Pitch	P ₀ Hole Pitch	Reel Diameter	Units per Reel
-QB	QFN (7x7mm)	28	16mm	12mm	4mm	329mm (13in)	1000

Tape and Reel Packaging per the following conditions:

Tape Width: 16 mm
 Tape Pitch (part to part): 12 mm
 Component Orientation: Parts are to be oriented with the PIN 1 closest to the tape's round sprocket holes on the tape's trailing edge.
 Reel Diameter: 329 mm (13 inch)

Note: Tape and Reel packaging is ordered with a -000T suffix. Package is available in 500 unit reels through designated sales channels. Minimum order quantities should be discussed with your local sales representative.

18.0-30.0 GHz GaAs Receiver

QFN, 7x7 mm

July 2008 - Rev 10-Jul-08

Tech Note [1] Assumptions on Modulation - The effect of intermodulation on the performance of a QAM radio is determined by many factors. By making some reasonable assumptions, it can be deduced that the XR1002 will conform with ETSI-specified high receive power requirements when operating in radios with modulations of up to 256QAM and higher.

For a Gray-coded QAM signals passing through a AWGN channel, an optimal receiver will require the C/N ratios shown in Figure 1.

QAM level	C/N for 1E-3(dB)	Assumed IM3 for 1E-3 (dBm)	IIP3 for 1E-3 (dBm)
16	16.6	-39.6	-14.7
64	22.6	-45.6	-11.7
128	25.6	-48.6	-10.2
256	28.6	-51.6	-8.7

Figure 1: C/N and IM3/IIP3 values for QAM (Pin=-20dBm and BER=1E-3)

To estimate the IM3 required to produce a BER of 1E-3 involves many approximations, and assumptions on the radio and modem characteristics. Following is an example which is based on the assumptions listed. All of the values of 'Assumed IM3 for 1E-3' listed in Figure 1 are derived using this method.

For a total input power at the receiver of -20dBm, this equates to a per-tone level of -23dBm, for a two-tone input. From Figure 1, an optimal 64 QAM receiver will require a 22.6dB C/N for a 1E-3 BER [F]. Therefore, the assumed in-band IM3 for 1E-3 performance is $-23 - 22.6 = -45.6$ dBm. From this, the required IIP3 for 64 QAM is $-23 + 22.6/2 = -11.7$ dBm.

Assumptions:

- [A] The C/N figure for 1E-3 BER assumes a matched receiver with no implementation loss, and no degradation due to phase noise.
- [B] All third order intermodulation falls in the pass-band. In reality, some of the intermodulation will fall in the adjacent channels, and can be removed by filtering. This assumption makes this analysis conservative.
- [C] The amplitude distribution of the distortion products can be approximated to that of thermal noise. There is a relatively high degree of uncertainty in this assumption as the peak to average ratio for the signal depends on alpha, and the statistics of the third order signal distortion are unknown.
- [D] The addition of interference at a level of 6dB below the AWGN due to the channel, increases the effective noise by 1dB. This is true if the interference has identical Gaussian statistics to the channel's AWGN.
- [E] The receiver input level range is set at an upper limit of -20dBm for 1E-3 BER performance [1][2][3]. This input level is referenced before the branching [1][2][3], which in reality may bring the upper limit down below -21 dBm. The exact number will depend on the particular system, so a worst-case hypothetical situation of no branching loss will be assumed.
- [F] The 1E-3 BER performance can depend greatly on the presence and performance of FEC. The worst case situation of NO FEC has been assumed in these derivations.

References:

- [1] ETSI EN 300 198 V1.4.1 (2001-02): "Fixed Radio Systems; Point-to-point equipment; Parameter for radio systems for the transmission of digital signals operating at 23 GHz"
- [2] ETSI EN 300 431 V1.3.1 (2001-02): "Fixed Radio Systems; Point-to-point equipment; Parameters for radio system for the transmission of digital signals operating in the frequency range 24,5 GHz to 29,50 GHz"
- [3] ETSI EN 300 197 V1.5.1 (2001-10): "Fixed Radio Systems; Point-to-point equipment; Parameters for radio system for the transmission of digital signals operating at 32 GHz and 38 GHz"

18.0-30.0 GHz GaAs Receiver QFN, 7x7 mm

July 2008 - Rev 10-Jul-08

Handling and Assembly Information

CAUTION! - Mimix Broadband MMIC Products contain gallium arsenide (GaAs) which can be hazardous to the human body and the environment. For safety, observe the following procedures:

- Do not ingest.
- Do not alter the form of this product into a gas, powder, or liquid through burning, crushing, or chemical processing as these by-products are dangerous to the human body if inhaled, ingested, or swallowed.
- Observe government laws and company regulations when discarding this product. This product must be discarded in accordance with methods specified by applicable hazardous waste procedures.

Life Support Policy - Mimix Broadband's products are not authorized for use as critical components in life support devices or systems without the express written approval of the President and General Counsel of Mimix Broadband. As used herein: (1) Life support devices or systems are devices or systems which, (a) are intended for surgical implant into the body, or (b) support or sustain life, and whose failure to perform when properly used in accordance with instructions for use provided in the labeling, can be reasonably expected to result in a significant injury to the user. (2) A critical component is any component of a life support device or system whose failure to perform can be reasonably expected to cause the failure of the life support device or system, or to affect its safety or effectiveness.

Package Attachment - This packaged product from Mimix Broadband is provided as a rugged surface mount package compatible with high volume solder installation. The package is a low-cost plastic package. Vacuum tools or other suitable pick and place equipment may be used to pick and place this part. Care should be taken to ensure that there are no voids or gaps in the solder connection so that good RF, DC and ground connections are maintained. Voids or gaps can eventually lead not only to RF performance degradation, but reduced reliability and life of the product due to thermal stress.

Typical Reflow Profiles

Reflow Profile	SnPb	Pb Free
Ramp Up Rate	3-4 °C/sec	3-4 °C/sec
Activation Time and Temperature	60-120 sec @ 140-160 °C	60-180 sec @ 170-200 °C
Time Above Melting Point	60-150 sec	60-150 sec
Max Peak Temperature	240 °C	265 °C
Time Within 5 °C of Peak	10-20 sec	10-20 sec
Ramp Down Rate	4-6 °C/sec	4-6 °C/sec

Part Number for Ordering

XR1002-QB-0N00
XR1002-QB-0N0T
XR1002-QB-EV1

Description

Ni/Au plated RoHS compliant QFN 7x7 28L surface mount package in bulk quantity
Ni/Au plated RoHS compliant QFN 7x7 28L surface mount package in tape and reel
XR1002-QB Evaluation Module

We also offer this part with alternative plating options. Please contact your regional sales manager for more information regarding different plating types.



Proper ESD procedures should be followed when handling this device.

Mimix Broadband, Inc., 10795 Rockley Rd., Houston, Texas 77099
Tel: 281.988.4600 Fax: 281.988.4615 mimixbroadband.com

Page 10 of 10

Characteristic Data and Specifications are subject to change without notice. ©2008 Mimix Broadband, Inc.
Export of this item may require appropriate export licensing from the U.S. Government. In purchasing these parts, U.S. Domestic customers accept their obligation to be compliant with U.S. Export Laws.