

GaAs SPDT Terminated Switch

DC - 2.5 GHz

SW-337, SW-338, SW-339

V2.00

Features

- Very Low Power Consumption: 75 μ W
- Low Insertion Loss: 0.5 dB
- High Isolation: 33 dB up to 2 GHz (SW-337, SW-338)
28 dB up to 2 GHz (SW-339)
- Very High Intercept Point: 46 dBm IP_3
- Nanosecond Switching Speed
- Temperature Range: -40°C to +85°C
- Low Cost SOIC8 Plastic Package
- Tape and Reel Packaging Available¹

Description

M/A-COM's SW-337, SW-338 and SW-339 are GaAs MMIC SPDT terminated switches in a low cost SOIC 8-lead surface mount plastic package. They are ideally suited for use where very low power consumption is required. Typical applications include transmit/receive switching, switch matrices, and filter banks in systems such as: radio and cellular equipment, PCM, GPS, fiber optic modules, and other battery powered radio equipment. The difference between the switches is in the pin configuration.

The SW-337, SW-338 and SW-339 are fabricated with monolithic GaAs MMICs using a mature 1-micron process. The process features full chip passivation for increased performance and reliability.

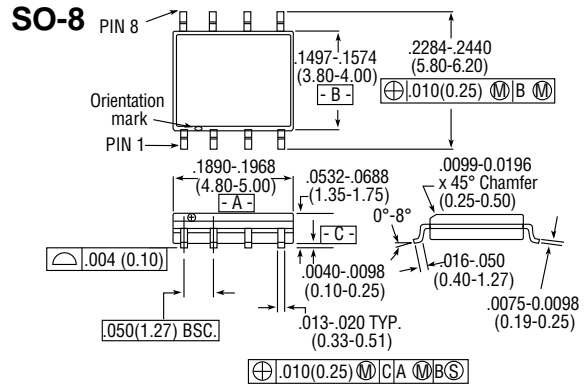

8-Lead SOP outline dimensions

Narrow body .150

(All dimensions per JEDEC No. MS-012-AA, Issue C)

Dimensions in () are in mm.

Unless otherwise noted: .xxx = ± 0.010 (.xx = ± 0.25)

.xx = ± 0.02 (.x = ± 0.5)

Ordering Information

Part Number	Package
SW-337 PIN	SOIC 8 Lead
SW-337 TR	Forward Tape & Reel
SW-337 RTR	Reverse Tape & Reel
SW-338 PIN	SOIC 8 Lead
SW-338 TR	Forward Tape & Reel
SW-338 RTR	Reverse Tape & Reel
SW-339 PIN	SOIC 8 Lead
SW-339 TR	Forward Tape & Reel
SW-339 RTR	Reverse Tape & Reel

Electrical Specifications, $T_A = \pm 25^\circ\text{C}$

Parameter	Test Conditions ²	Unit	SW-337, SW-338			SW-339		
			Min.	Typ.	Max.	Min.	Typ.	Max.
Insertion Loss	DC - 0.1 GHz	dB		0.4	0.6		0.4	0.6
	DC - 0.5 GHz	dB		0.5	0.7		0.5	0.7
	DC - 1.0 GHz	dB		0.5	0.7		0.5	0.7
	DC - 2.0 GHz	dB		0.7	0.9		0.7	0.9
Isolation	DC - 0.1 GHz	dB	50	53		50	53	
	DC - 0.5 GHz	dB	43	46		43	46	
	DC - 1.0 GHz	dB	36	39		35	38	
	DC - 2.0 GHz	dB	30	33		25	28	
VSWR	On	DC - 2.0 GHz		1.2:1			1.2:1	
	Off	DC - 2.0 GHz		1.2:1			1.2:1	
Trise, Tfall Ton, Toff Transients	10% to 90% RF, 90% to 10% RF	nS		7			7	
	50% Control to 90% RF, 50% Control to 10% RF	nS		10			10	
	In Band	mV		25			25	
One dB Compression Point	Input Power	0.05 GHz		25			25	
	Input Power	0.5 - 2.0 GHz		30			30	
2nd Order Intercept	Measured Relative to Input Power	0.05 GHz		60			60	
	(for two-tone input power up to +5 dBm)	0.5 - 2.0 GHz		65			65	
3rd Order Intercept	Measured Relative to Input Power	0.05 GHz		40			40	
	(for two-tone input power up to +5 dBm)	0.5 - 2.0 GHz		46			46	

1. Refer to "Tape and Reel Packaging" Section, or contact factory.

2. All measurements with 0, -5 control voltages at 1 GHz in a 50 Ω system, unless otherwise specified.

Specifications Subject to Change Without Notice.

M/A-COM, Inc.

North America: Tel. (800) 366-2266 ■ Asia/Pacific: Tel. +81 (03) 3226-1671 ■ Europe: Tel. +44 (1344) 869 595
Fax (800) 618-8883 Fax +81 (03) 3226-1451 Fax +44 (1344) 300 020

Absolute Maximum Ratings

Parameter	Absolute Maximum ¹
Max. Input Power	
0.05 GHz	+27 dBm
0.5 – 2.0 GHz	+34 dBm
Control Voltage	+5V, -8.5V
Operating Temperature	-40°C to +85°C
Storage Temperature	-65°C to +150°C

1. Operation of this device above any one of these parameters may cause permanent damage.

Functional Schematics

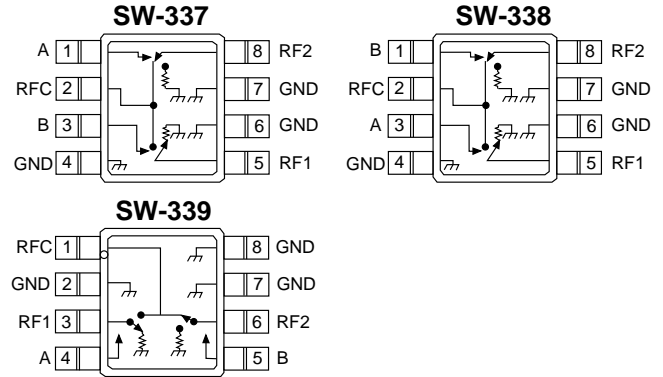

Typical Performance @ +25°C

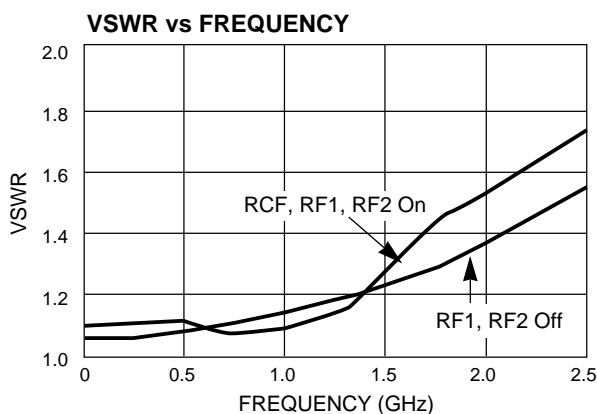
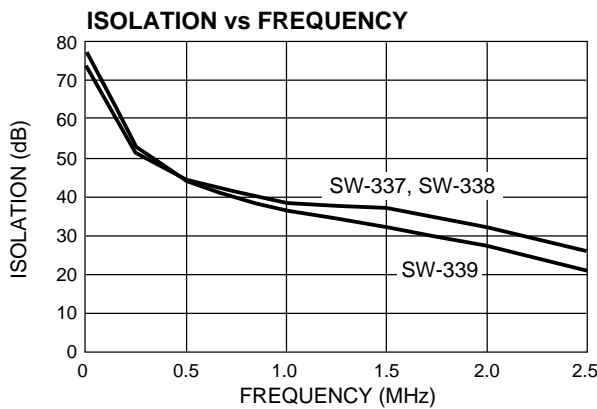
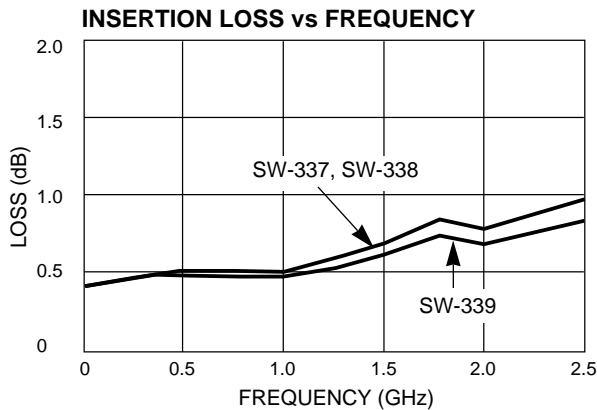

Pin Configuration

SW-337		SW-338		SW-339	
Pin No.	Description	Pin No.	Description	Pin No.	Description
1	A	1	B	1	RF Common
2	RF Common	2	RF Common	2	GND
3	B	3	A	3	RF1
4	GND	4	GND	4	A
5	RF1	5	RF1	5	B
6	GND	6	GND	6	RF2
7	GND	7	GND	7	GND
8	RF2	8	RF2	8	GND

Truth Table

Control Inputs		Condition of Switch RF Common to Each RF Port	
A	B	RF1	RF2
1	0	ON	OFF
0	1	OFF	ON

"0" – 0 – -0.2V @ 20 µA max.
 "1" – -5V @ 30 µA Typ to -8V @ 720 µA max.

Electrical Schematic

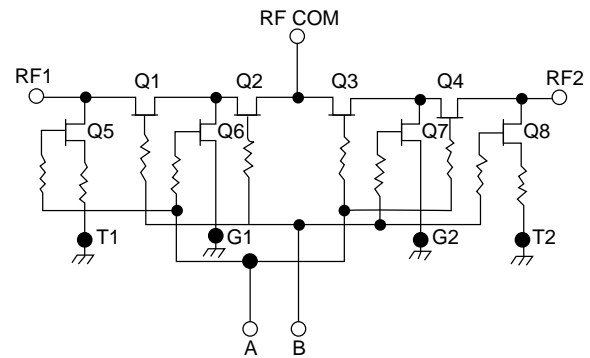

Specifications Subject to Change Without Notice.