

# Single Side Band Speech Scrambler

## FEATURES

- Speech Scrambling/Descrambling
- High Dynamic Range
- Low Voltage Operation
- Low Power Consumption
- On Board Crystal Oscillator
- Uses Common Color Burst Crystal
- Full Duplex Operation
- Selectable Scramble Enable/Disable
- Switched Capacitor Filter
- COPLAMOS® n-Channel Silicon Gate Technology

## PIN CONFIGURATION

N/C	1	14	XTAL <sub>2</sub>
Scramble	2	13	N/C
Vss	3	12	XTAL <sub>1</sub>
Ref	4	11	In-A
In-B	5	10	Out-A
Out-B	6	9	Vdd
Vdd <sub>A</sub>	7	8	Vss <sub>A</sub>

## GENERAL DESCRIPTION

The COM9046 is a monolithic integrated circuit containing a voice scrambler, a descrambler and a crystal oscillator. It is designed to provide speech communication equipment with a privacy feature. The COM9046 is also designed to operate with power supply voltages as low as  $\pm 2$ Volts. The low voltage operation and low power consumption of the COM9046 make it ideal for use in portable equipment.

Two identical speech channels are contained in the COM9046 for full duplex operation. Either channel is capa-

ble of performing the scrambling or descrambling function. These functions can be enabled or disabled via an external pin. The on-board oscillator employs an inexpensive 3.58 MHz TV color-burst crystal. Switched capacitor techniques are used to perform analog signal processing in the COM9046.

Typical applications for the COM9046 are Voice Communications, Cellular Phones, Wireless Phones, PBX's, Dictation Machines, Two-way Radios and Audio Recording Equipment.

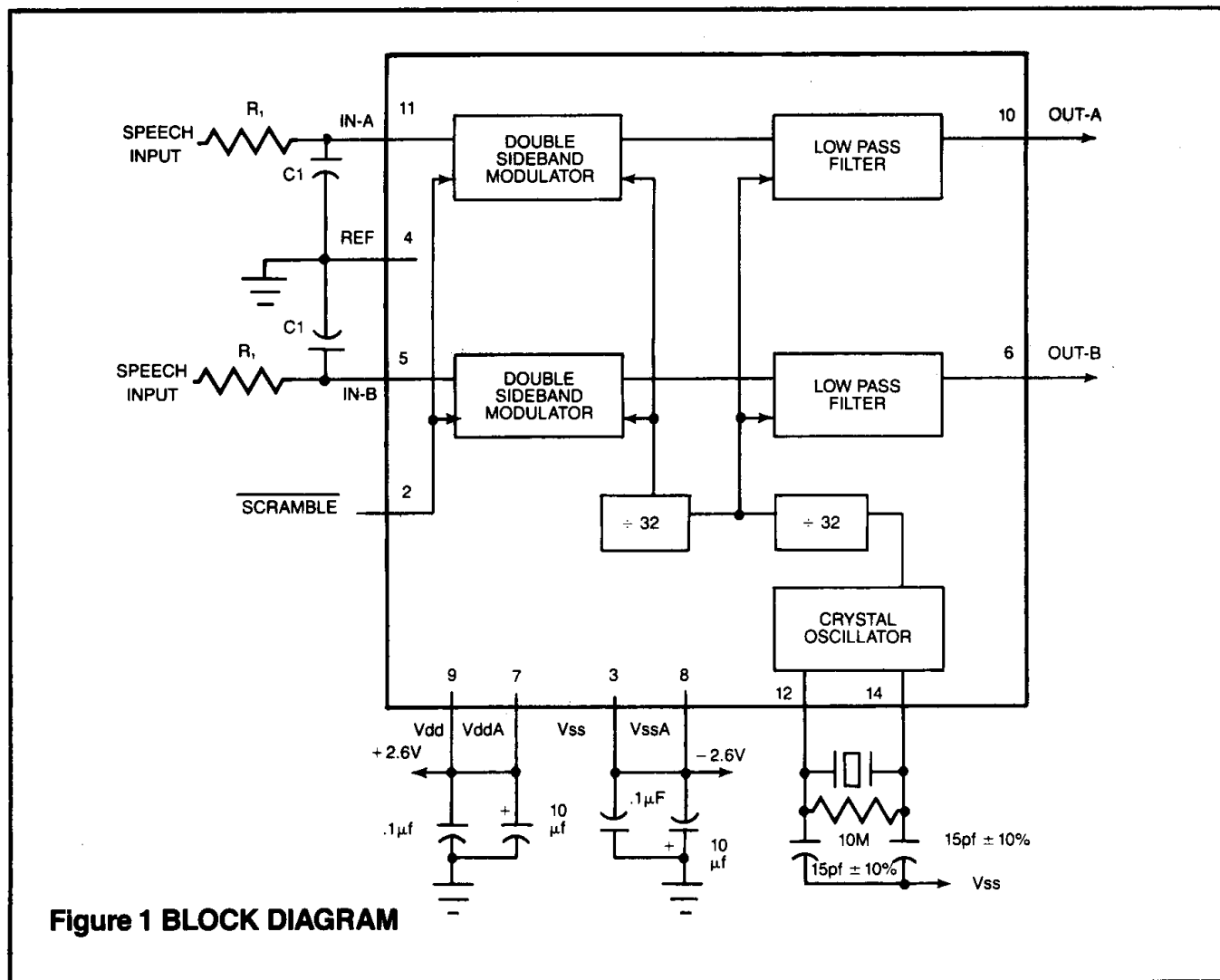

**Figure 1 BLOCK DIAGRAM**

### DESCRIPTION OF PIN FUNCTIONS

PIN #	NAME	SYMBOL	DESCRIPTION
1	N/C	—	No Connection
2	Scramble	—	Vss applied to this pin asserts the scramble; Vdd asserts non-scramble.
3	Digital Supply	Vss	Negative digital supply. Vss is typically -2.6 volts with respect to pin 4.
4	Ref Input	Ref	Analog ground or mid-supply voltage. This is the chip 0 volt reference.
5	Audio Input B	In-B	Channel B audio input. D.C. voltage must be 0V with respect to pin 4.
6	Audio Output B	Out-B	Channel B audio output. DC voltage is 0V typical with respect to pin 4.
7	Analog Supply	Vdd <sub>A</sub>	Positive analog supply. Vdd is typically +2.6 volts with respect to pin 4.
8	Analog Supply	Vss <sub>A</sub>	Negative analog supply. Vss <sub>A</sub> is typically -2.6 volts with respect to pin 4.
9	Digital Supply	Vdd	Positive digital supply. Vss is typically +2.6 volts with respect to pin 4.
10	Audio Output A	Out-A	Channel A audio output. DC voltage is 0V typical with respect to pin 4.
11	Audio Input A	In-A	Channel B audio input. D.C. voltage must be 0V with respect to pin 4.
12	Crystal input/ Ext Clock	XTAL <sub>1</sub>	Crystal Oscillator input or external clock. External clock frequency should be 3.58MHz with an amplitude of 4Vp-p and 0VDC.
13	N/C	—	No connection
14	Crystal input	XTAL <sub>2</sub>	Crystal Oscillator output. This pin is left floating when external clock is applied to pin 12.

## OPERATION

Figure 1 shows a block diagram of the chip. Also shown in Figure 1 are the required external components.

Since switched-capacitor filters are used on the chip, the input speech signal must first be filtered by an anti-aliasing one-pole low pass filter before it is applied to the Audio input pin. The filter 3dB break point, which is determined by the product of C1 and R1 plus the output impedance of the audio source, should be less than 20KHz. This filter is required only if high frequency noise is present at the input. To maintain an output signal to noise ratio of 40dB, any unwanted signal higher than 3.5KHz contained in the speech input must be filtered to 40dB below the nominal speech input level, due to the fact that the on-chip modulator is switched at 3.5KHz.

The on-chip double sideband modulator can be turned on or off by asserting the SCRAMBLE input pin. The 3.5KHz switching frequency of the modulator is generated by divid-

ing the output of the oscillator by 1024. The modulator output contains two sidebands centered at the suppressed switching frequency of 3.5KHz. The upper sideband is attenuated by a 4th order Butterworth lowpass filter. The filter, consisting of two biquad switched capacitor filters in cascade, is clocked at 111.9KHz. The inverted input speech spectrum appears at the filter output, and is available at the Audio Output pin. The filter output circuit is designed to drive a maximum capacitive load of 5pf in parallel with a minimum resistance of 15K ohms.

A parallel resonant crystal oscillator is employed in the device. The parallel resonant crystal should have a maximum series resistance of 150 ohms with a shunt capacitance of 5pf. To insure reliable oscillator performance, the components shown connected to XTAL pins 14 and 12 in Figure 1 should be used.

## ELECTRICAL CHARACTERISTICS

**COM9046**

### MAXIMUM GUARANTEED RATINGS\*:

Operating Temperature Range .....	-15°C to +55°C
Storage Temperature Range .....	-55°C to +125°C
Lead Temperature (soldering, 10 sec.) .....	+325°C
Positive Voltage on any pin with respect to Vss .....	+6.5 V
Negative Voltage on any pin with respect to Vss .....	-0.3 V

\*Stresses above those listed may cause permanent damage to the device. This is a stress rating only and functional operation of the device at these or any other condition above those indicated in the operational sections of this specifications is not implied.

NOTE: When powering this device from laboratory or system power supplies, it is important that the Absolute Maximum Ratings not be exceeded or device failure can result. Some power supplies exhibit voltage spikes or "glitches" on their outputs when the AC power is switched on and off. In addition, voltage transients on the AC power line may appear on the DC output. If this possibility exists, it is suggested that a clamp circuit be used.

**ELECTRICAL CHARACTERISTICS** (Ta = -10°C to +50°C, Vdd = Vdd<sub>A</sub> = +2.6V ± 5%, Vss = Vss<sub>A</sub> = -2.6V ± 5%.)

Parameter	Min	Typ	Max	Units	Comments
Supply Current		5	8	ma	
Insertion Loss		0	1	db	
Audio Voltage Swing		0.8	1	Vp-p	
S/N Ratio	40			db	
Modulation Frequency		3.5		KHz	
Bandedge of Sideband Filter		3.2		KHz	
Scramble Input High	Vdd-1.0		Vdd	V	
Scramble Logic Low	Vss		Vss + .3	V	
Input Resistance		5		M Ohm	
Dynamic Output Resistance		900		Ohm	
3.5KHz Feedthrough		-60	-50	db	

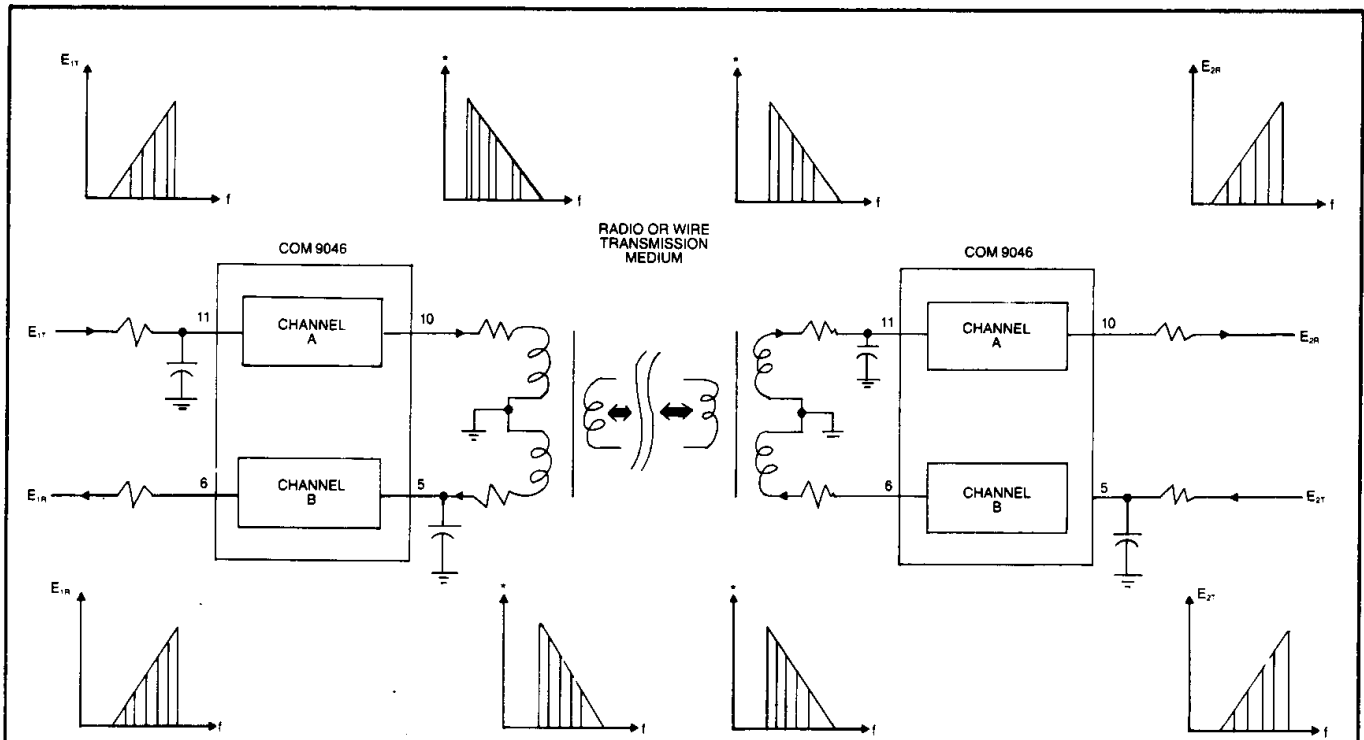

**Figure 2 TYPICAL APPLICATION**

\*Inverted Frequency Spectrum of the Inspect Signals are Transmitted on the Transmission Medium.

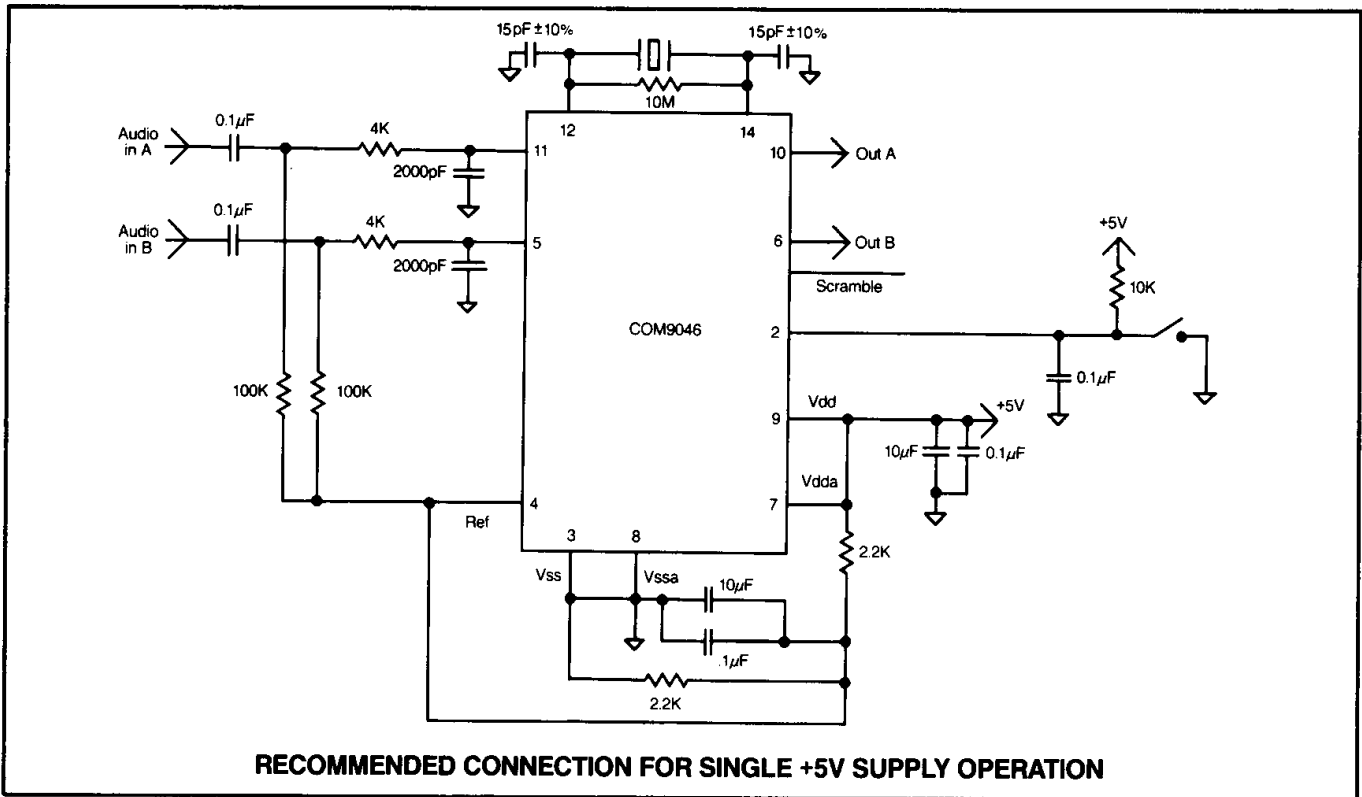

**RECOMMENDED CONNECTION FOR SINGLE +5V SUPPLY OPERATION**

**STANDARD MICROSYSTEMS CORPORATION**

35 Mercus Blvd. Hightstown, NJ 07888  
 (609) 273-3100 FAX: 609-271-8898

Circuit diagrams utilizing SMC products are included as a means of illustrating typical semiconductor applications; consequently complete information sufficient for construction purposes is not necessarily given. The information has been carefully checked and is believed to be entirely reliable. However, no responsibility is assumed for inaccuracies. Furthermore, such information does not convey to the purchaser of the semiconductor devices described any license under the patent rights of SMC or others. SMC reserves the right to make changes at any time in order to improve design and supply the best product possible.