

Description

The Bay Linear B34063A series is monolithic control circuit containing the primary functions required for DC-to-DC converters. These devices consist of an internal temperature compensated reference, comparator, controlled, duty cycle oscillator with an active current limit circuit, driver and high current output switch.

This series was specially designed to be incorporated in Step-Down and Step-Up and voltage-inverting applications with a minimum number of external component.

The B34063A is offer in 8-pin DIP or Surface mount package.

Features

- **Operation from 3.0V to 40V input**
- **Low Standby Current**
- **Current Limiting**
- **Output Switch Current to 1.5A**
- **Output voltage Adjustable**
- **Frequency Operation to 100 kHz**
- **Precision 2% Reference**
- **Step-Up-Step Down or inverting Switching regulator**
- **Direct Replacement for MC34063**

Applications

- **CD ROM**
- **Mother Board**
- **SMPS Power Supply**

Pin Connection

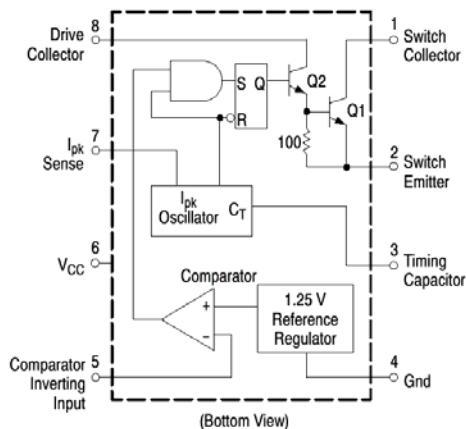

This device contains 51 active transistors.

Figure 1. Representative Schematic Diagram

Ordering Information

SO-8 8-pin	P-DIP 8-pin	Operating Temp. Range
B34063AM	B34063AP	0°C to 70°C
B34063AIM	B34063AIP	-40°C to 85°C
B34063AEM	B34063AEP	-40°C to 125°C

All Marking will be B34063X. The Temperature will be specified in out side Box. X=Package type



8-Pin Surface Mount

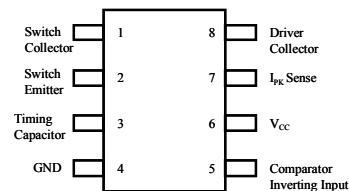

Top View

Absolute Maximum Rating

Parameter	Symbol	Value	Unit
Supply Voltage	V_{CC}	40	V
Comparator Input Voltage Range	$V_{I(Comp)}$	-0.3 ~ + 40	V
Switch Collector Voltage	$V_{C(SW)}$	40	V
Switch Emitter Voltage	$V_{E(SW)}$	40	V
Switch Collector to Emitter Voltage	$V_{CE(SW)}$	40	V
Driver Collector Voltage	$V_{C(DR)}$	40	V
Switch Current	I_{SW}	1.5	I

Electrical Characteristics

($V_{CC} = 5.0V$, $T_A = T_{LOW}$ to T_{HIGH} (Note 3), unless otherwise specified)

Parameter	Symbol	Conditions	MIN	TYP	MAX	UNIT
OSCILATOR						
Charging Current	I_{CHG}	$V_{VV}=5$ to $40V$, $T_A = 25\text{ }^\circ\text{C}$	24	35	42	μA
Discharging Current	I_{DISHG}	$V_{CC} = 5$ to $40V$, $T_A = 25\text{ }^\circ\text{C}$	140	220	260	μA
Frequency	f_{OSC}	$T_A = 25\text{ }^\circ\text{C}$	24	33	42	kHz
Discharge in To Charge Current Ratio	K	$V_7 = V_{CC}$ $T_A = 25\text{ }^\circ\text{C}$	5.2	6.5	7.5	-
Current Limit Sense Voltage	$V_{SENSE(C.L)}$	$I_{CHG} = I_{DISCHG}$, $T_A = 25\text{ }^\circ\text{C}$	250	300	350	mV
OUTPUT SWITCH (Note 4)						
Saturation Voltage Darlington Connection	$V_{CE(SAT)}^1$	$I_{SW} = 1.0A$, Pins 1, 8 connected $V_{C(drive)} = V_{C(SW)}$	-	1.0	1.3	V
Saturation Voltage (Note 5)	$V_{CE(SAT)}^2$	$I_{SW} = 1.0A$, $V_{C(drive)} = 50mA$	-	0.45	0.7	V
DC Current Gain	$G_{I(DC)}$	$I_{SW} = 1.0A$, $V_{CE} = 5.0V$, $T_A = 25\text{ }^\circ\text{C}$	50	75	-	-
Collector off State Current	$I_{C(OFF)}$	$V_{CE} = 40V$	-	40	100	μA
COMPARATOR						
Threshold Voltage	V_{TH}	$T_A = 25\text{ }^\circ\text{C}$ $T_A = T_{LOW}$ to T_{high}	1.225 1.21	1.25	1.275 1.29	V
Threshold Voltage Line Reg. B34063A, B34063AI, B34063AE	ΔV_{TH}	$V_{CC} = 3V$ to $40V$	- -	1.4 1.4	5.0 6.0	mV
Input Bias Current	I_{BIAS}	$V_1 = 0V$	-	-20	-400	nA
TOTAL DEVICE						
Supply Current	I_{CC}	$V_{CC} = 5V$ to $40V$, $C_T = 0.001\mu\text{F}$, Pin7= V_{CC} , $V_5 > V_{TH}$ pin2=Gnd, Remaining pins open	-	-	4.0	mA

Note3: $T_{low} = 0\text{ }^\circ\text{C}$ for B34063A, $-40\text{ }^\circ\text{C}$ for B34063AI, AE, $T_{high} = +70\text{ }^\circ\text{C}$ for the B34063A, $T_{high} = +85\text{ }^\circ\text{C}$ for the B34063AI, $+125\text{ }^\circ\text{C}$ for the B34063AE

Note4: Low Duty cycle pulse techniques are used during test to maintain junction temp. as close to ambient temp. as possible.

Note5: If the output switch is driven into hard saturation (non-Darlington configuration) at low switch current ($\leq 300mA$) and high driver currents ($\geq 30mA$). It may take up to $2.0\text{ }\mu\text{s}$ for it to come out of saturation. This condition will shorten the off time at frequencies $\geq 30\text{ kHz}$. And is magnified at high temperatures. This condition does not occur with a Darlington configuration. Since the output switch can not saturate. If a non-Darlington configuration is used the following output drive condition is recommended:

$$\text{Forces } \beta \text{ of output switch : } I_c \text{ output} / I_c \text{ driver} - 7.0mA \geq 10$$

The 100Ω resistor in the emitter of the driver device requires about 7.0 mA before the output switch conducts

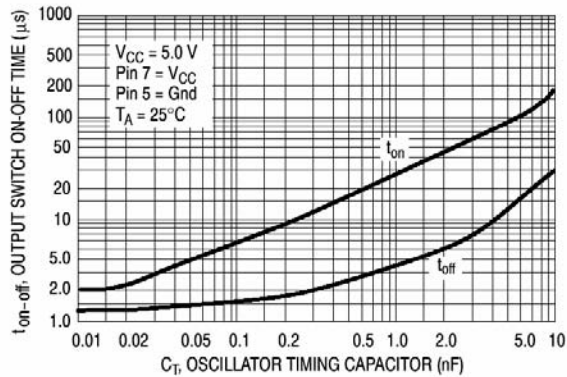

Figure 2. Output Switch On-Off Time versus Oscillator Timing Capacitor

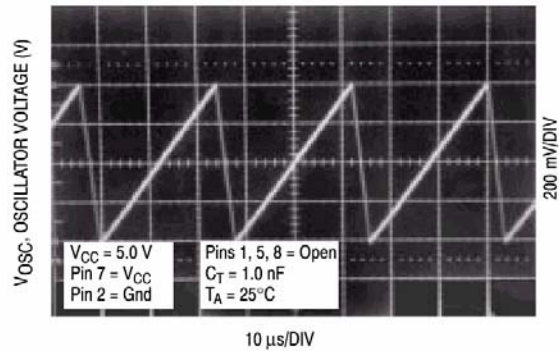

Figure 3. Timing Capacitor Waveform

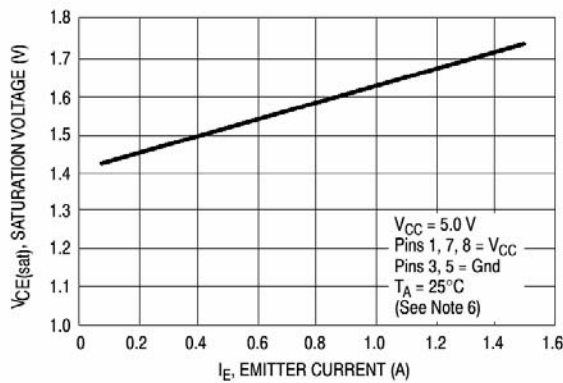

Figure 4. Emitter Follower Configuration Output Saturation Voltage versus Emitter Current

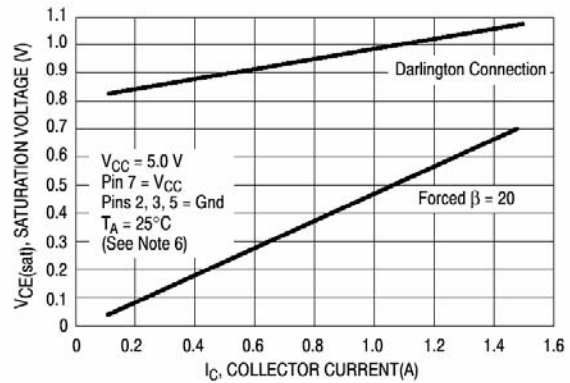

Figure 5. Common Emitter Configuration Output Switch Saturation Voltage versus Collector Current

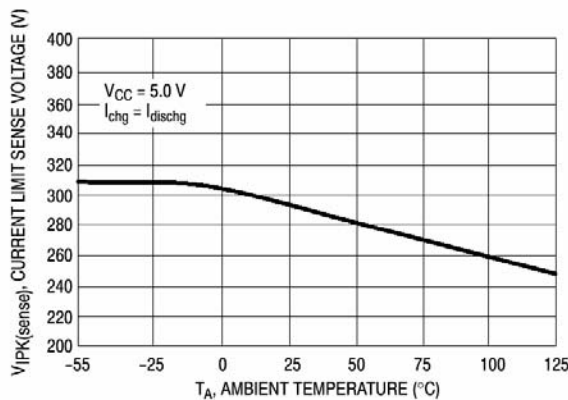

Figure 6. Current Limit Sense Voltage versus Temperature

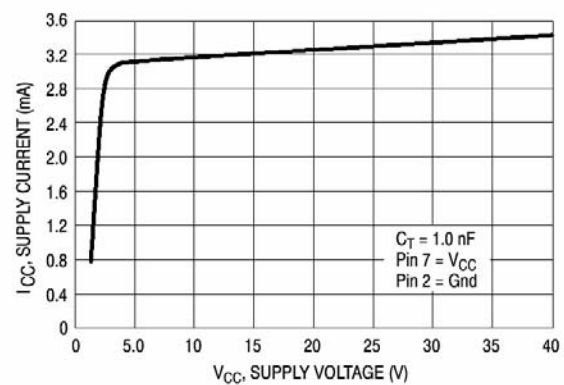
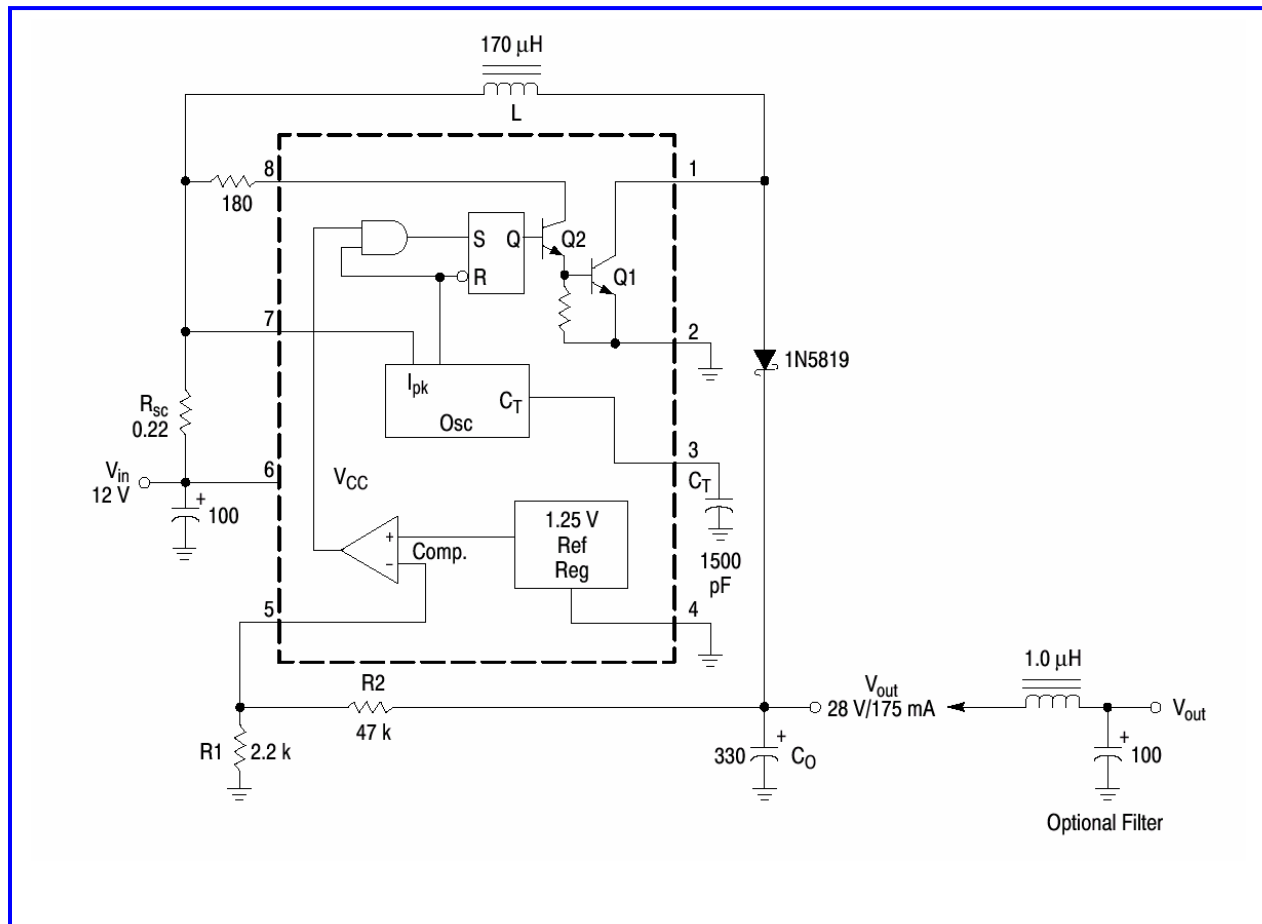
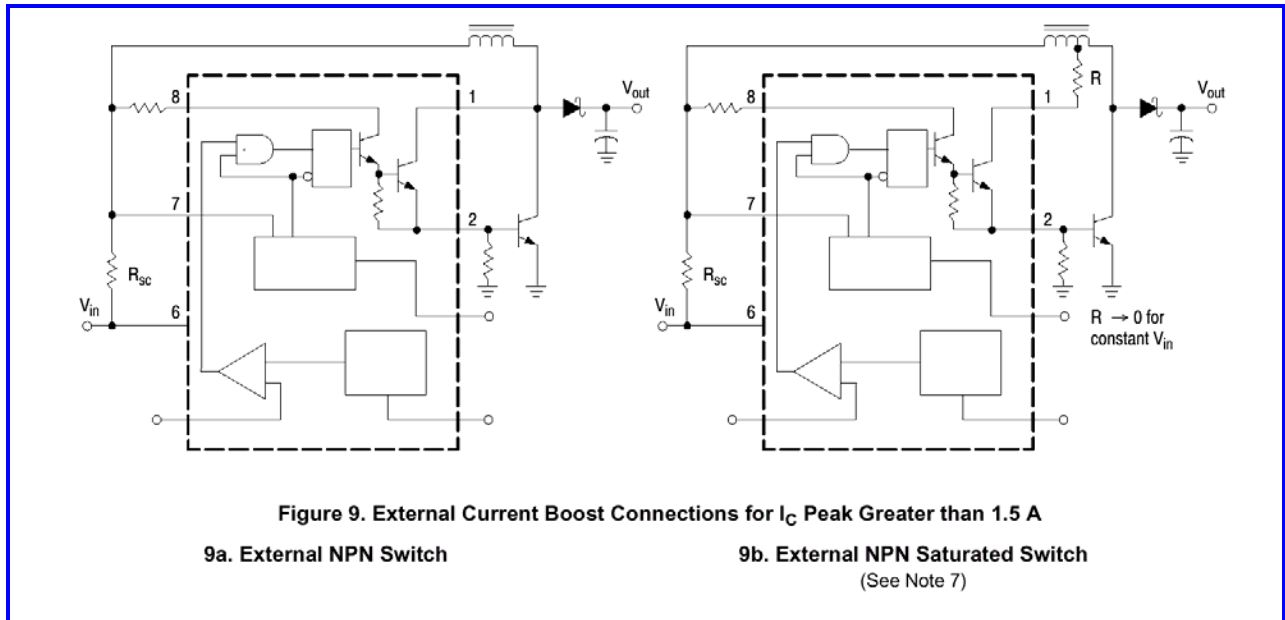

Figure 7. Standby Supply Current versus Supply Voltage

Figure 8. Step-Up Converter



Test	Conditions	Results
Line Regulation	$V_{IN} = 8.0\text{ V to }16\text{ V}, I_O = 175\text{ mA}$	30 mV = ± 0.05%
Load Regulation	$V_{IN} = 12\text{ V}, I_O = 75\text{ mA to }175\text{ mA}$	10 mV = ± 0.01%
Output Ripple	$V_{IN} = 12\text{ V}, I_O = 175\text{ mA}$	400 mVp-p
Efficiency	$V_{IN} = 12\text{ V}, I_O = 175\text{ mA}$	89.2%
Output Ripple With Optional Filter	$V_{IN} = 12\text{ V}, I_O = 175\text{ mA}$	40 mVp-p



Note 7: If the output switch is driven into hard saturation (non-Darlington configuration) at low switch currents (3-300 mA) and high driver currents (> 30 mA), it may take up to 2.0 ms to come out of saturation. This condition will shorten the off time at frequencies > 30 kHz, and is magnified at high temperatures. This condition does not occur with a Darlington configuration, since the output switch cannot saturate. If a non-Darlington configuration is used, the following output drive condition is recommended.

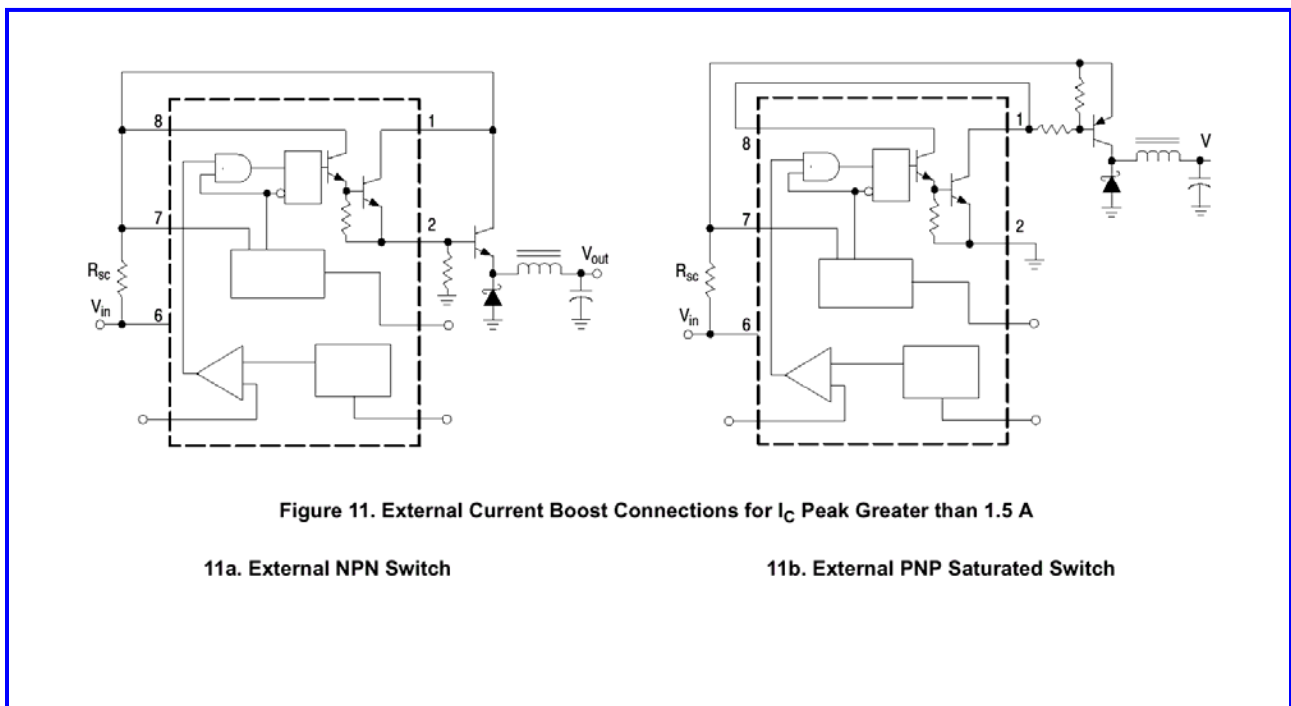
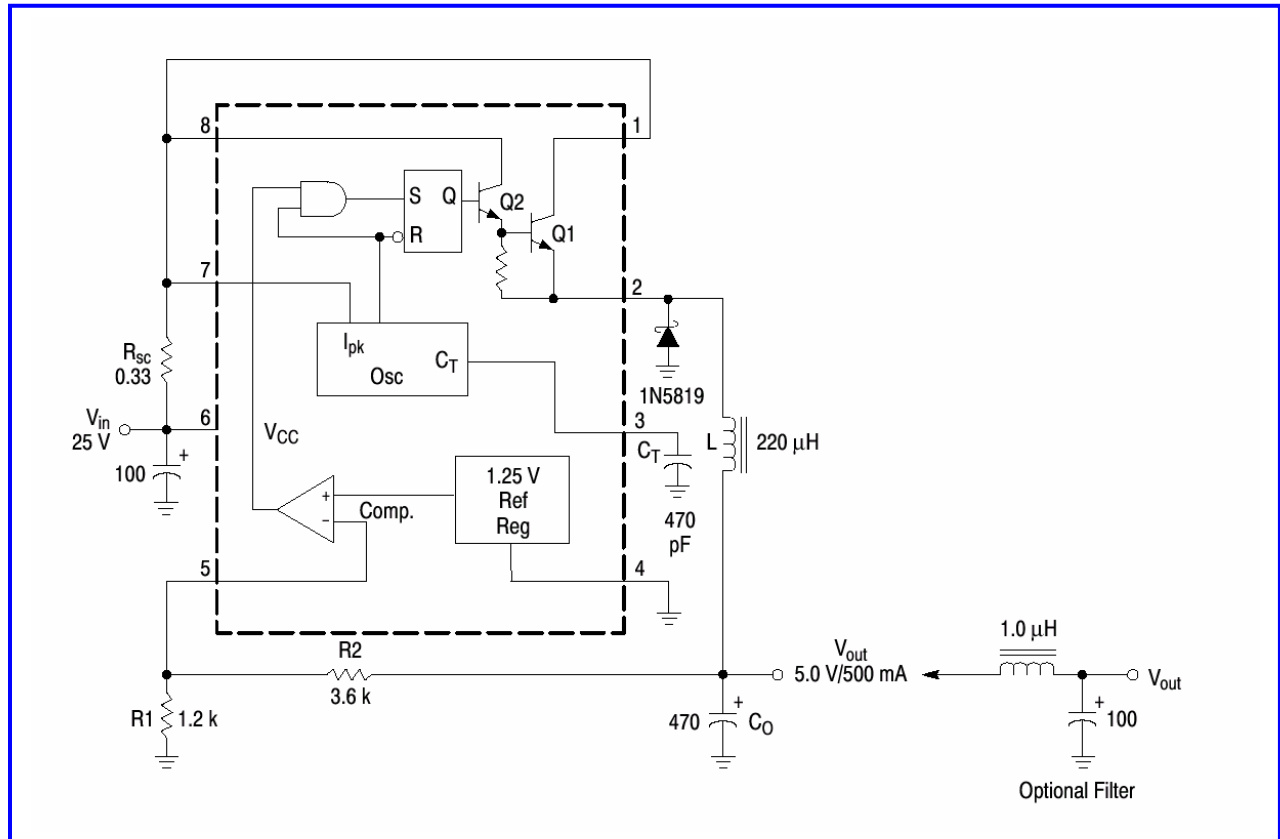
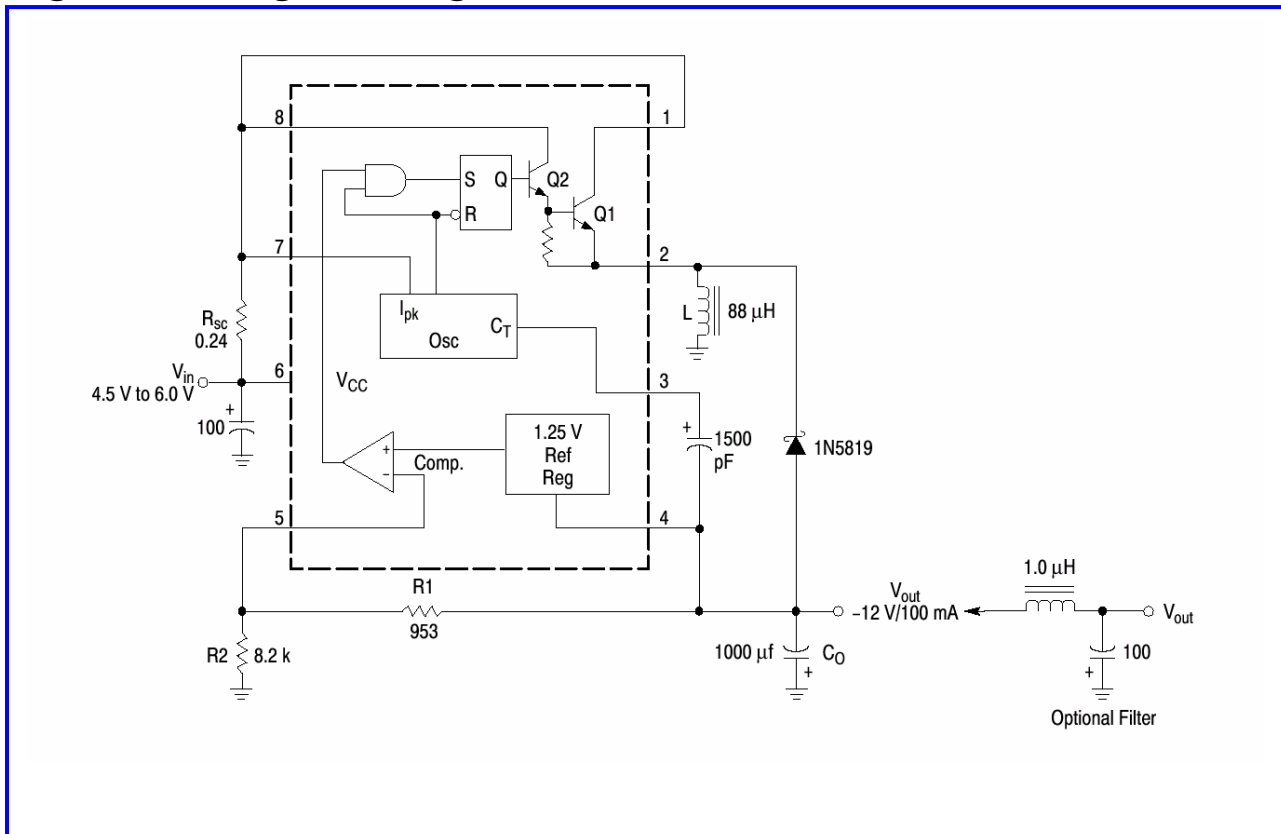

Figure 10. Step-Down Converter



Test	Conditions	Results
Line Regulation	$V_{IN} = 15 \text{ V to } 25 \text{ V}, I_O = 500 \text{ mA}$	12 mV = $\pm 0.12\%$
Load Regulation	$V_{IN} = 25 \text{ V}, I_O = 50 \text{ mA to } 500 \text{ mA}$	3.0 mV = $\pm 0.03\%$
Output Ripple	$V_{IN} = 25 \text{ V}, I_O = 500 \text{ mA}$	120 mVp-p
Short Circuit Current	$V_{IN} = 25 \text{ V}, R_L = 0.1\Omega$	1.1A
Efficiency	$V_{IN} = 25 \text{ V}, I_O = 500 \text{ mA}$	83.7%
Output Ripple With Optional Filter	$V_{IN} = 25 \text{ V}, I_O = 500 \text{ mA}$	40 mVp-p

Figure 12. Voltage Inverting Converter



Test	Conditions	Results
Line Regulation	$V_{IN} = 4.5 \text{ V to } 6.0 \text{ V}, I_O = 100 \text{ mA}$	$3 \text{ mV} = \pm 0.12\%$
Load Regulation	$V_{IN} = 5.0 \text{ V}, I_O = 10 \text{ mA to } 100 \text{ mA}$	$0.022 \text{ mV} = \pm 0.09\%$
Output Ripple	$V_{IN} = 5.0 \text{ V}, I_O = 100 \text{ mA}$	500 mVp-p
Short Circuit Current	$V_{IN} = 5.0 \text{ V}, R_L = 0.1 \Omega$	910mA
Efficiency	$V_{IN} = 5.0 \text{ V}, I_O = 100 \text{ mA}$	62.2%
Output Ripple With Optional Filter	$V_{IN} = 5.0 \text{ V}, I_O = 100 \text{ mA}$	70 mVp-p

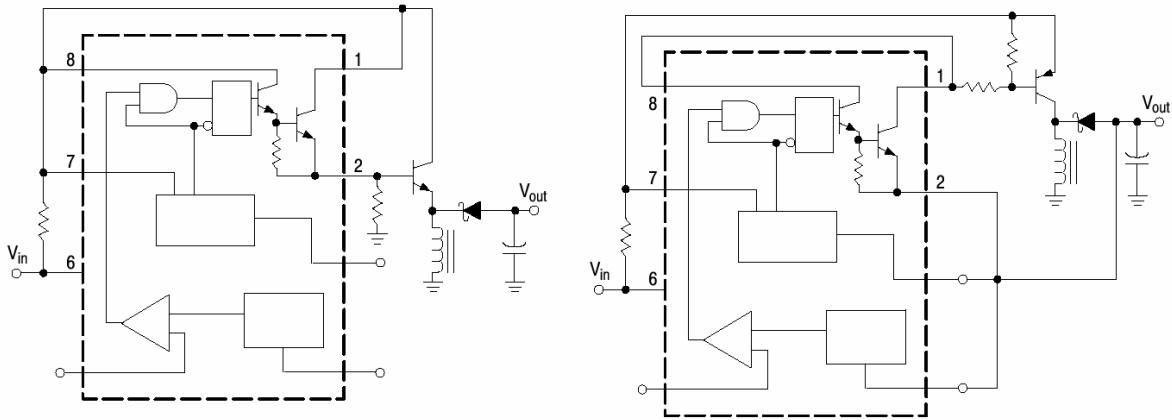
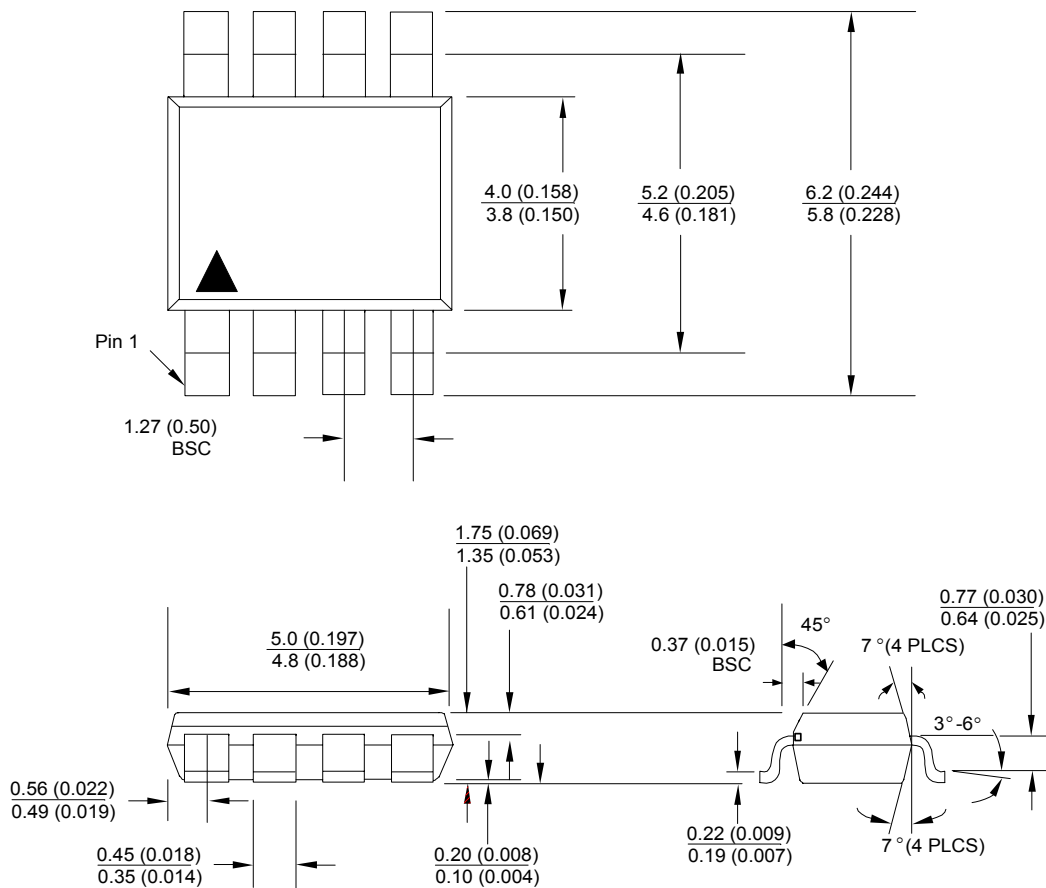

Figure 13. External Current Boost Connections for I_C Peak Greater than 1.5 A

13a. External NPN Switch

13b. External PNP Saturated Switch



Advance Information- These data sheets contain descriptions of products that are in development. The specifications are based on the engineering calculations, computer simulations and/ or initial prototype evaluation.

Preliminary Information- These data sheets contain minimum and maximum specifications that are based on the initial device characterizations. These limits are subject to change upon the completion of the full characterization over the specified temperature and supply voltage ranges.

The application circuit examples are only to explain the representative applications of the devices and are not intended to guarantee any circuit design or permit any industrial property right to other rights to execute. Bay Linear takes no responsibility for any problems related to any industrial property right resulting from the use of the contents shown in the data book. Typical parameters can and do vary in different applications. Customer's technical experts must validate all operating parameters including "Typical" for each customer application.

LIFE SUPPORT AND NUCLEAR POLICY

Bay Linear products are not authorized for and should not be used within life support systems which are intended for surgical implants into the body to support or sustain life, in aircraft, space equipment, submarine, or nuclear facility applications without the specific written consent of Bay Linear President.
