

# AT-106-PIN

Digital Attenuator  
50.0 dB, 6-Bit, TTL Driver, DC-2.0 GHz

Rev. V10

## Features

- Attenuation: 1 dB steps to 50 dB
- Temperature Stability:  $\pm 0.18$  dB from  $-55^{\circ}\text{C}$  to  $+85^{\circ}\text{C}$  Typical
- Low DC Power Consumption
- Hermetic Surface Mount Package
- Integral TTL Driver
- 50 Ohm Nominal Impedance
- Lead-Free CR-13 Package
- 260°C Reflow Compatible
- RoHS\* Compliant

## Description

M/A-COM's AT-106-PIN is a GaAs FET 6-bit digital attenuator with a 1 dB minimum step size and 50 dB total attenuation. This attenuator and integral TTL driver is in a hermetically sealed ceramic 24-lead surface mount package. The AT-106-PIN is ideally suited for use where accuracy, fast switching, very low power consumption and low intermodulation products are required. Typical applications include dynamic range setting in precision receiver circuits and other gain/leveling control circuits. Environmental screening is available. Contact the factory for information.

## Ordering Information

Part Number	Package
AT-106-PIN	Bulk Packaging
AT-106-TR	1000 piece reel
AT-106-TB	Sample Test Board

Note: Reference Application Note M513 for reel size information.

## Functional Schematic

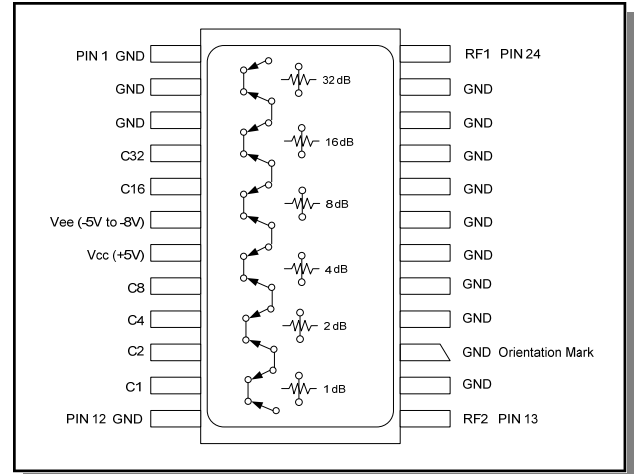

## Pin Configuration

Pin No.	Function	Pin No.	Function
1	GND	13	RF2
2	GND	14	GND
3	GND	15	GND
4	C32	16	GND
5	C16	17	GND
6	Vee (-5V to -8V)	18	GND
7	Vcc (+5V)	19	GND
8	C8	20	GND
9	C4	21	GND
10	C2	22	GND
11	C1	23	GND
12	GND	24	RF1

The metal bottom of the case must be connected to RF and DC ground.

\* Restrictions on Hazardous Substances, European Union Directive 2002/95/EC.

## Electrical Specifications: (From $-55^{\circ}\text{C}$ to $+85^{\circ}\text{C}$ )<sup>1</sup>

Parameter	Test Conditions	Frequency	Units	Min	Typ	Max
Reference Insertion Loss	—	DC - 0.5 GHz	dB	—	3.5	4.0
		DC - 1.0 GHz	dB	—	3.9	4.4
		DC - 2.0 GHz	dB	—	4.2	4.8
Attenuation Accuracy <sup>2</sup>	Any Single Bit Any Combination of Bits (For attenuation to 26 dB) Any Combination of Bits (For attenuation 27 to 50 dB)	DC - 2.0 GHz	dB	± (0.3 +4% of atten. setting)		
		DC - 2.0 GHz	dB	± (0.4 +4% of atten. setting)		
		DC - 1.5 GHz	dB	± (0.5 +5% of atten. setting)		
VSWR	—	0.05 - 0.10 GHz 0.101 - 2.0 GHz	Ratio Ratio	— —	— —	2.0:1 1.8:1
Trise, Tfall	10% to 90%	—	ns	—	—	50
Ton, Toff	50% Control to 90/10% RF	—	ns	—	—	150
Transients	In-Band (peak-peak)	—	mV	—	50	—
1 dB Compression	Input Power Input Power	0.05 GHz	dBm	—	+20	—
		0.5 - 2.0 GHz	dBm	—	+28	—
Input IP3	For two-tone Input Power Up to +5 dBm	0.05 GHz	dBm	—	+34	—
		0.5 - 2.0 GHz	dBm	—	+46	—
Input IP2	For two-tone Input Power Up to +5 dBm	0.05 GHz	dBm	—	+45	—
		0.5 - 2.0 GHz	dBm	—	+79	—
Vcc	—	—	V	4.5	5.0	5.5
Vee	—	—	V	-8.0	—	-5.0
Icc	Vcc = 4.5 to 5.5V Vctl = 0 to 0.8V, or Vcc -2.1V to Vcc	—	mA	—	—	6.0
Iee	Vee = -5.0 to -8.0V	—	mA	—	—	1.0
Vctl Vctl	Logic 0 (TTL) Logic 1 (TTL)	—	V	0.0	—	0.8
		—	V	2.0	—	5.0
Input Leakage Current (Low)	0 to 0.8V	—	μA	—	—	1.0
Input Leakage Current (High)	2.0 to 5.0V	—	μA	—	—	1.0

1. All specifications apply when operated with bias voltages of +5V for Vcc and -5.0V for Vee.
2. This attenuator is guaranteed monotonic.

## Absolute Maximum Ratings <sup>3,4</sup>

Parameter	Absolute Maximum
Max Input Power 0.05 GHz 0.5 - 2.0 GHz	+27 dBm +34 dBm
$V_{CC}$	$-0.5V \leq V_{CC} \leq +7.0V$
$V_{EE}$	$-8.5V \leq V_{EE} \leq +0.5V$
$V_{CC} - V_{EE}$	$-0.5V \leq V_{CC} - V_{EE} \leq 14.5V$
$V_{in}^5$	$-0.5V \leq V_{in} \leq V_{CC} + 0.5V$
Operating Temperature	$-55^{\circ}C$ to $+125^{\circ}C$
Storage Temperature	$-65^{\circ}C$ to $+150^{\circ}C$

- Exceeding any one or combination of these limits may cause permanent damage to this device.
- M/A-COM does not recommend sustained operation near these survivability limits.
- Standard CMOS TTL interface, latch-up will occur if logic signal is applied prior to power supply

## Handling Procedures

Please observe the following precautions to avoid damage:

## Static Sensitivity

Gallium Arsenide Integrated Circuits are sensitive to electrostatic discharge (ESD) and can be damaged by static electricity. Proper ESD control techniques should be used when handling these devices.

## Typical Performance Curves

### Insertion Loss vs. Frequency

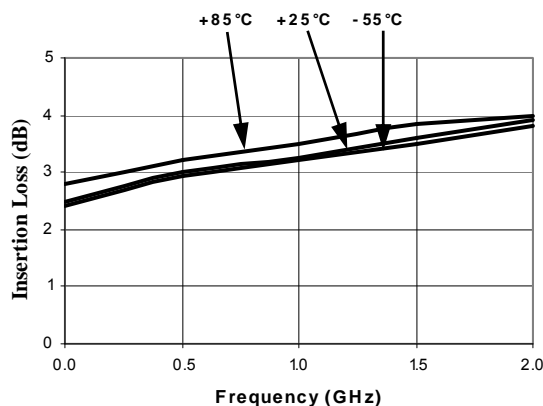

## Recommended PCB Configuration

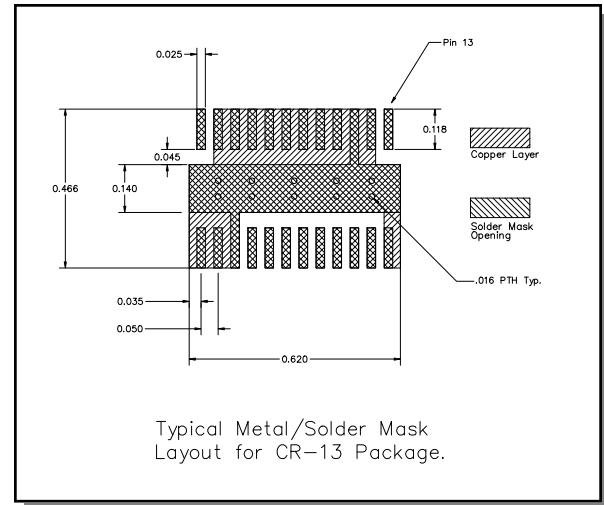

## Truth Table (Digital Attenuator)

Control Inputs						Attenuation
C6	C5	C4	C3	C2	C1	
0	0	0	0	0	0	Reference
0	0	0	0	0	1	1 dB
0	0	0	0	1	0	2 dB
0	0	0	1	0	0	4 dB
0	0	1	0	0	0	8 dB
0	1	0	0	0	0	16 dB
1	0	0	0	0	0	32 dB
1	1	1	1	1	1	63 dB

0=TTL Low, 1=TTL High

### Attenuation Accuracy vs. Frequency

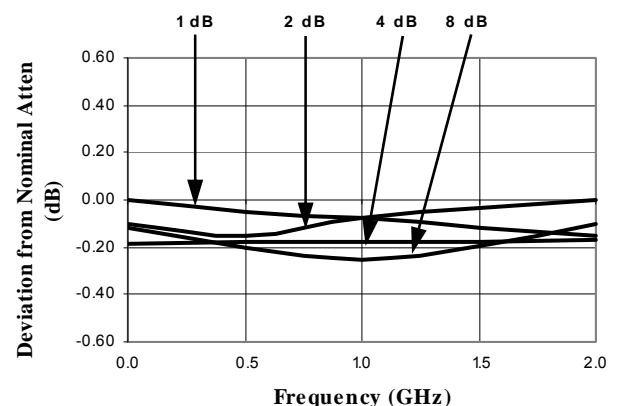

# AT-106-PIN

Digital Attenuator  
50.0 dB, 6-Bit, TTL Driver, DC-2.0 GHz

Rev. V10

## Typical Performance Curves

Attenuation Accuracy vs. Frequency

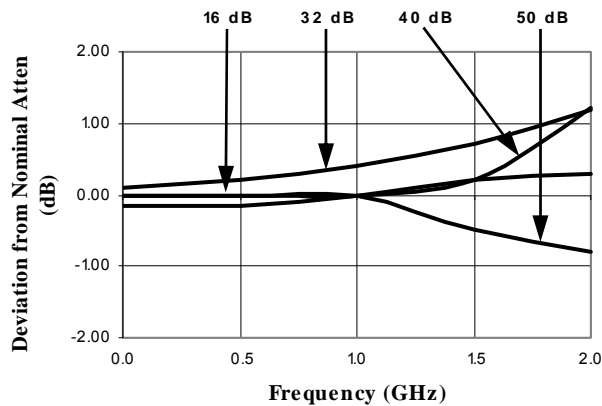

RF1 VSWR vs. Frequency

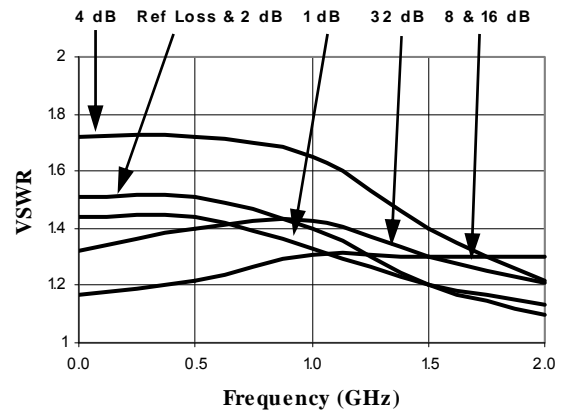

RF2 VSWR vs. Frequency

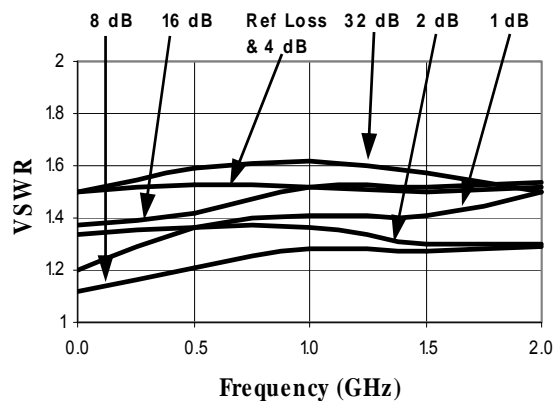

## Lead-Free, CR-13 Ceramic Package<sup>†</sup>

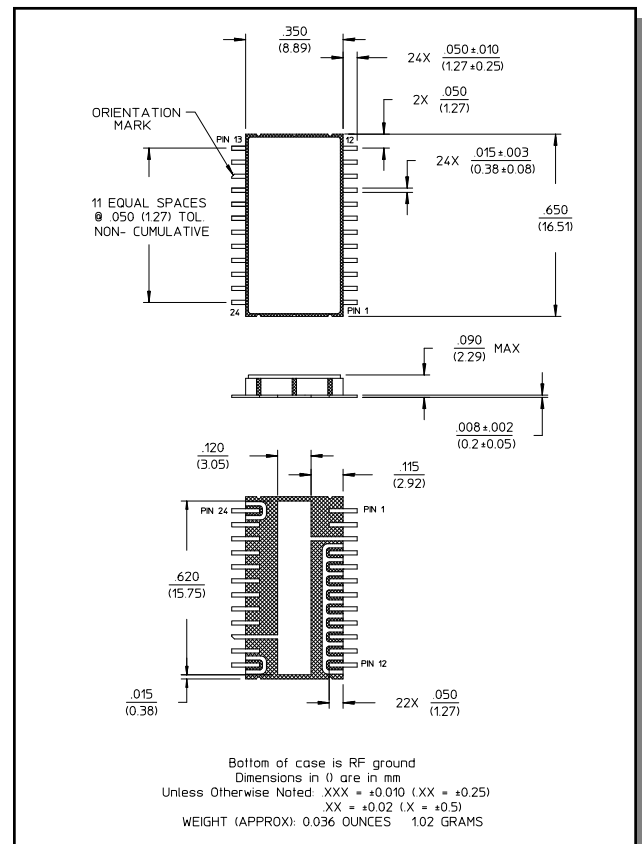

<sup>†</sup> Reference Application Note M538 for lead-free solder reflow recommendations.

**ADVANCED:** Data Sheets contain information regarding a product M/A-COM Technology Solutions is considering for development. Performance is based on target specifications, simulated results, and/or prototype measurements. Commitment to develop is not guaranteed.  
**PRELIMINARY:** Data Sheets contain information regarding a product M/A-COM Technology Solutions has under development. Performance is based on engineering tests. Specifications are typical. Mechanical outline has been fixed. Engineering samples and/or test data may be available. Commitment to produce in volume is not guaranteed.

• North America Tel: 800.366.2266 • Europe Tel: +353.21.244.6400  
• India Tel: +91.80.4155721 • China Tel: +86.21.2407.1588  
Visit [www.macontech.com](http://www.macontech.com) for additional data sheets and product information.

M/A-COM Technology Solutions Inc. and its affiliates reserve the right to make changes to the product(s) or information contained herein without notice.