

## Description

The GM7630 is a multi-output positive voltage regulator, designed to provide fixed precision output voltages of 5.1V, 8V at current up to 0.5A and 12V at current up to 1A with external PNP transistor.

An internal reset circuit generates a reset pulse when the output 1 decrease below the regulated value. Output2 & 3 can be disabled by TTL input. Protection features include over voltage protection, short circuit protection, and thermal shutdown.

## Features

- ◆ Output Currents up to 0.5A (output1 & 2)
- ◆ Output Current up to 1A with External Transistor (output3)
- ◆ Fixed Precision Output 1 voltage  $5.1V \pm 2\%$
- ◆ Fixed Precision Output 2 voltage  $8V \pm 2\%$
- ◆ Control Signal Generator for Output 3 voltage ( $12V \pm 2\%$ )
- ◆ Reset Facility for Output Voltage1
- ◆ Output 2,3 with Disable by TTL Input
- ◆ Current Limit Protection at Each Output
- ◆ Thermal Shut Down

## TYPICAL APPLICATION

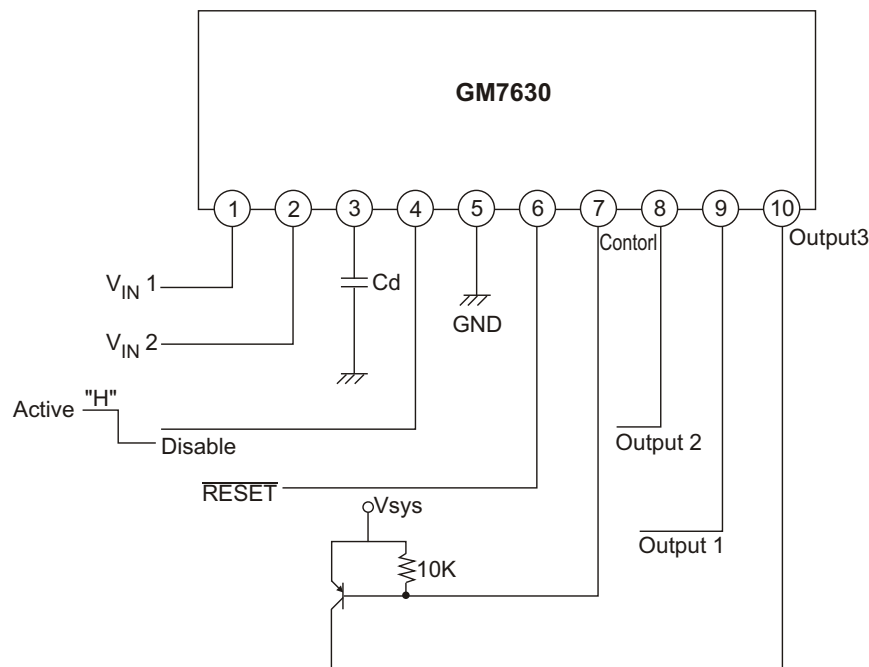

◆ MARKING INFORMATION & PIN CONFIGURATIONS (TOP VIEW)

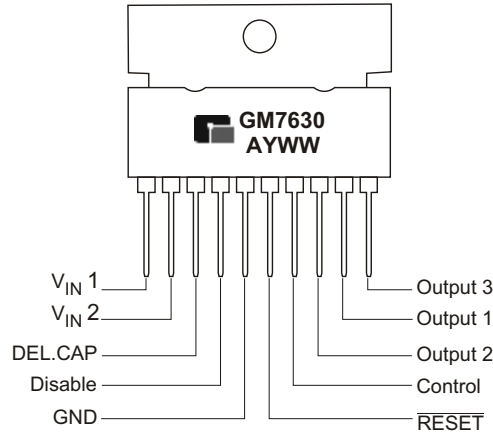

A = Assembly Location  
 Y = Year  
 WW = Work Week

◆ ORDERING INFORMATION

| Ordering Number | Package      | Shipping       |
|-----------------|--------------|----------------|
| GM7630SIP10T    | 10- SIP H/ S | 20 Units/ Tube |

\* For detail Ordering Number identification, please see last page.

### ◆ ABSOLUTE MAXIMUM RATINGS

| PARAMETER             | SYMBOL    | RATINGS  | UNITS | REMARK      |
|-----------------------|-----------|----------|-------|-------------|
| DC Input Voltage      | $V_{IN}$  | 20       | V     | -           |
| Disable Input Voltage | $V_C$     | 20       | V     | -           |
| Output Current        | $I_O$     | 0.5      | A     | -           |
| Power Dissipation     | $P_D$     | 1.5      | W     | No Heatsink |
| Junction Temperature  | $T_J$     | +150     | °C    | -           |
| Operating Temperature | $T_{opr}$ | 0 ~ +125 | °C    | -           |

### ◆ INTERNAL BLOCK DIAGRAM

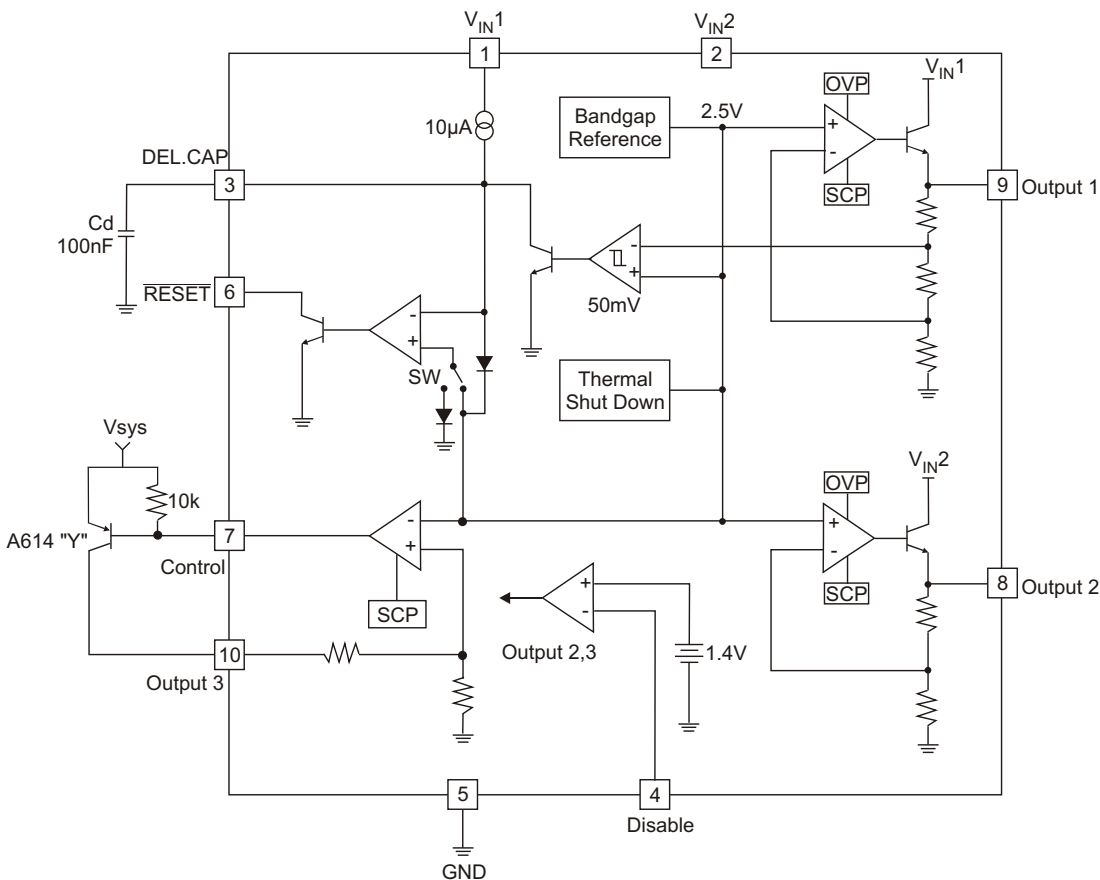

### ◆ ELECTRICAL CHARACTERISTICS

(Refer to test circuit  $V_{IN1}=7.5V$ ,  $V_{IN2}=10.5V$ ,  $T_J=25^\circ C$ , unless otherwise specified)

| Parameter                             | Symbol     | Condition   | Min         | Typ        | Max         | Unit            |
|---------------------------------------|------------|---|-------------|------------|-------------|-----------------|
| Output Voltage 1                      | $V_{O1}$   | $I_{O1}=10mA$ ,<br>$7.5V < V_{IN1} < 14V$<br>$5mA < I_{O1} < 500mA$   | 5.0<br>4.9  | 5.1<br>5.1 | 5.2<br>5.3  | V               |
| Output Voltage 2                      | $V_{O2}$   | $I_{O2}=10mA$ ,<br>$10.5V < V_{IN2} < 18V$<br>$5mA < I_{O2} < 500mA$  | 7.84<br>7.7 | 8<br>8     | 8.16<br>8.3 | V               |
| Dropout Output Voltage 1,2            | $V_{d1,2}$ | $I_{O1,2}=500mA$ ,  | -           | -          | 2.5         | V               |
| Line Regulation 1,2                   | $V_{O1,2}$ | $7.5V < V_{IN1} < 14V$<br>$10.5V < V_{IN2} < 18V$<br>$I_{O1,2}=200mA$ | -           | -          | 50<br>80    | mV              |
| Load Regulation 1, 2                  | $V_{O1,2}$ | $5mA < I_{O1} < 500mA$<br>$5mA < I_{O2} < 500mA$                      | -           | 0.1        | 100<br>160  | mV              |
| Output Voltage 3                      | $V_{O3}$   | $V_{sys}=13V$ , $I_{O3}=100mA$  | 11.7        | 12         | 12.3        | V               |
| Line Regulation 3                     | $V_{O3}$   | $13V < V_{IN3} < 18V$<br>$I_{O3}=100mA$                               | -           | -          | 120         | mV              |
| Load Regulation 3                     | $V_{O3}$   | $5mA < I_{O3} < 1A$   | -           | -          | 250         | mV              |
| Reset Pulse Delay                     | Trd        | $C_d=100nF$ , Note 1  | -           | 25         | -           | ms              |
| Saturation Voltage in Reset Condition | $V_{rL}$   | $I_6=5mA$   | -           | -          | 0.4         | V               |
| Leakage Current Pin 6                 | $I_{rH}$   | $V_6=10V$   | -           | -          | 10          | $\mu A$         |
| Output Voltage Thermal Drift          | STt        | $0^\circ C < T_J < +125^\circ C$ , Note 2                             | -           | 100        | -           | ppm/ $^\circ C$ |
| Short Circuit Output Current          | Isc 1,2    | $V_{IN1}=7.5V$ , $V_{IN2}=10.5V$                                      | -           | -          | 1.6         | A               |
| Disable Voltage High                  | $V_{disH}$ | Output 2 Active   | 2.0         | -          | -           | V               |
| Disable Voltage Low                   | $V_{disL}$ | Output 2 Disabled   | -           | -          | 0.8         | V               |
| Disable Bias Current                  | $I_{dis}$  | $0V < V_{dis} < 7V$   | -100        | -          | 2           | $\mu A$         |
| Junction Temperature for TSD          | Ttsd       | Note 2  | -           | 145        | -           | $^\circ C$      |
| Quiescent Current                     | $I_q$      | $I_{O1}=10mA$ , Output2 Disabled                                      | -           | -          | 2           | mA              |
| Reset Threshold Voltage               | $V_r$      | $K=V_{O1}$  | K -0.4      | K -0.25    | K -0.1      | V               |
| Reset Threshold Hysteresis            | $V_{rth}$  | Note 1  | 20          | 50         | 100         | mA              |

#### Notes:

1. To check the reset circuit, the reset output is low to discharge the delay capacitor(=Cd). if it's less than  $V_{O1}-0.25V$ . And the reset output is high when the delay capacitor voltage linearly increased by the internal current source(10 $\mu A$ ) if it's more than  $V_{O1}-0.2V$ . The equations of delay time is same as below.  $Trd = (Cd \times 2.5) / 10\mu A$

2. These parameters, although guaranteed, are not 100% tested in production.

◆ 10-SIP H/ S PACKAGE OUTLINE DIMENSIONS

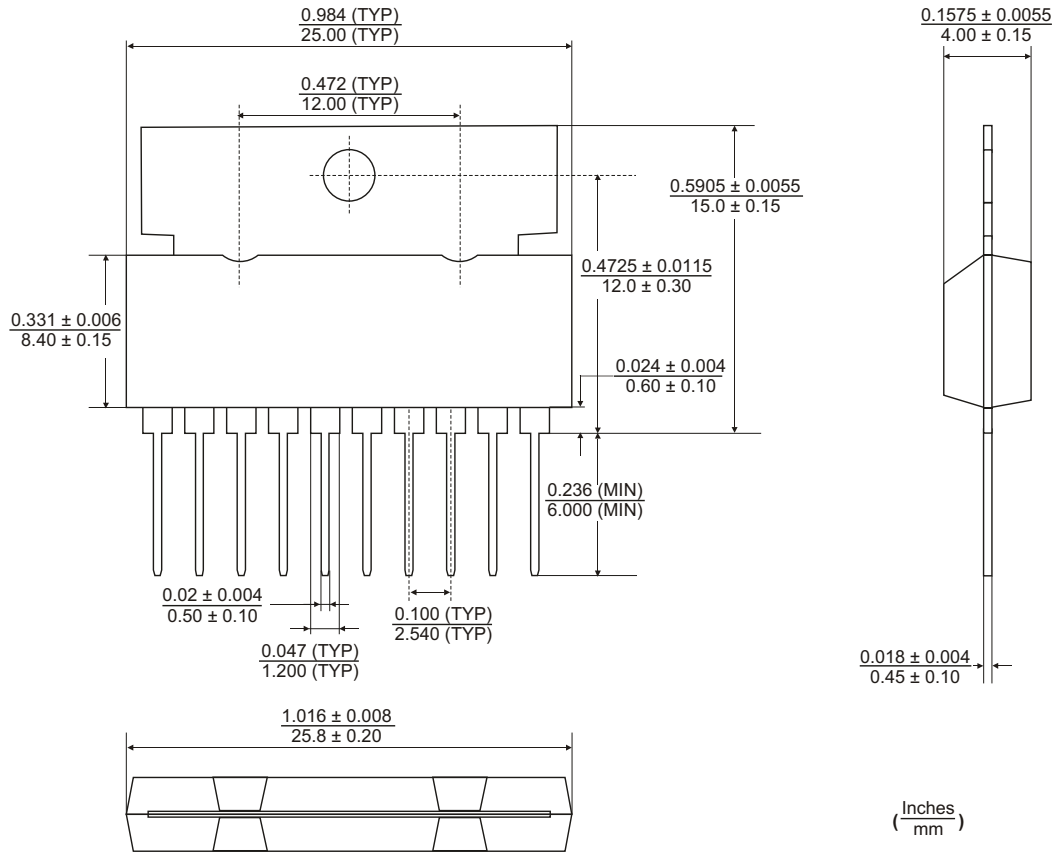

◆ ORDERING NUMBER

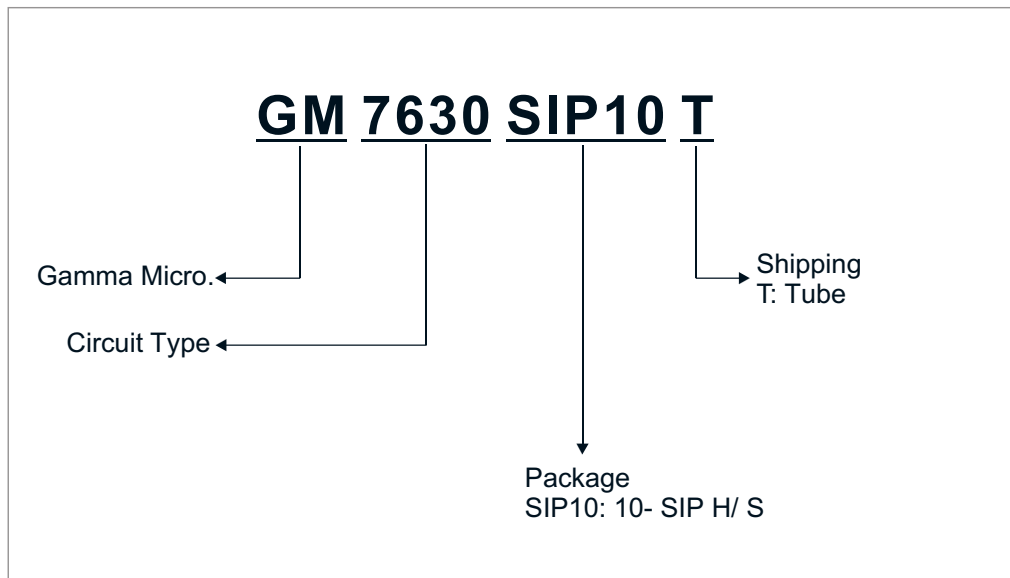

---

GAMMA Micro, , and  are registered trademarks of GAMMA MICROELECTRONICS INC. GAMMA reserves the right to make changes without further notice to any products herein. Information provided herein is alleged to be exact and consistent and this publication surpasses and replaces all information previously supplied.

GAMMA makes no warranty the suitability of its products for any particular purpose, nor does GAMMA assume any liability arising out of the application or use of any product or circuit, and specifically disclaims any and all liability including without limitation special, consequential or incidental damages.

GAMMA products are not authorized for using as critical components in life support devices or systems without prior written approval from GAMMA MICROELECTRONICS INC.

---