

## Description

GM7632 is a multi-output positive voltage regulator designed to provide fixed precision output voltages of 3.3V, 8V at current up to 0.5A and 5.1V at current up to 1A with external PNP transistor.

An internal reset circuit generates a reset pulse when the output 1 decrease below the regulated value. Output2 & 3 can be disabled by TTL input. Protection features include over voltage protection, short circuit protection and thermal shutdown.

## Features

- ◆ Output Currents up to 0.5A (output1 & 2)
- ◆ Output Current up to 1A with External Transistor (output3)
- ◆ Fixed Precision Output 1 voltage  $3.3V \pm 2\%$
- ◆ Fixed Precision Output 2 voltage  $8V \pm 2\%$  (GM7632)
- ◆ Control Signal Generator for Output 3 voltage ( $5.1V \pm 2\%$ )
- ◆ Reset Facility for Output Voltage1
- ◆ Output 2,3 with Disable by TTL Input
- ◆ Current Limit Protection at Each Output
- ◆ Thermal Shut Down

## TYPICAL APPLICATION

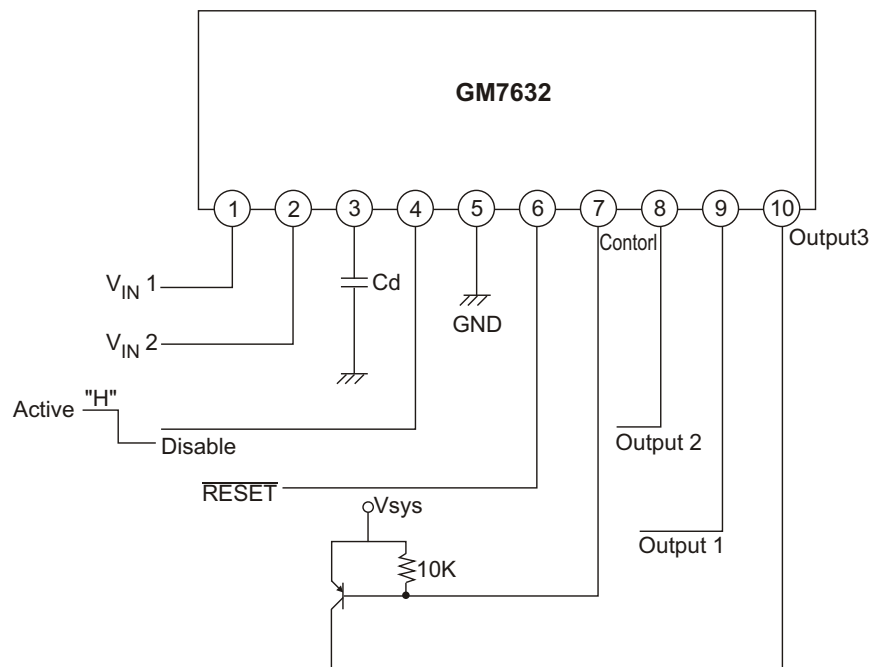

◆ MARKING INFORMATION & PIN CONFIGURATIONS (TOP VIEW)

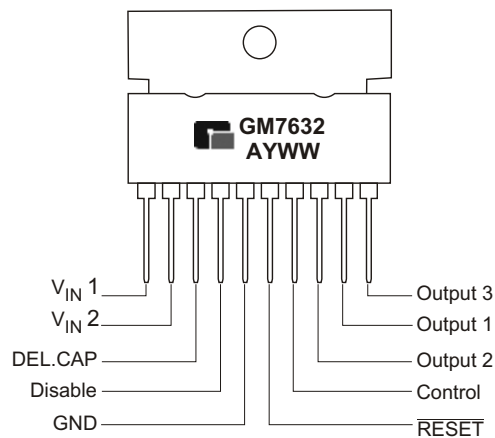

A = Assembly Location  
 Y = Year  
 WW = Weekly

◆ ORDERING INFORMATION

Ordering Number	Package	Shipping
GM7632SIP10T	10- SIP H/ S	20 Units/ Tube

\* For detail Ordering Number identification, please see last page.

### ◆ ABSOLUTE MAXIMUM RATINGS

PARAMETER	SYMBOL	RATINGS	UNITS	REMARK
DC Input Voltage	$V_{IN}$	20	V	-
Disable Input Voltage	$V_C$	20	V	-
Output Current	$I_O$	0.5	A	-
Power Dissipation	$P_D$	1.5	W	No Heatsink
Junction Temperature	$T_J$	+150	°C	-
Operating Temperature	$T_{opr}$	0 ~ +125	°C	-

### ◆ INTERNAL BLOCK DIAGRAM

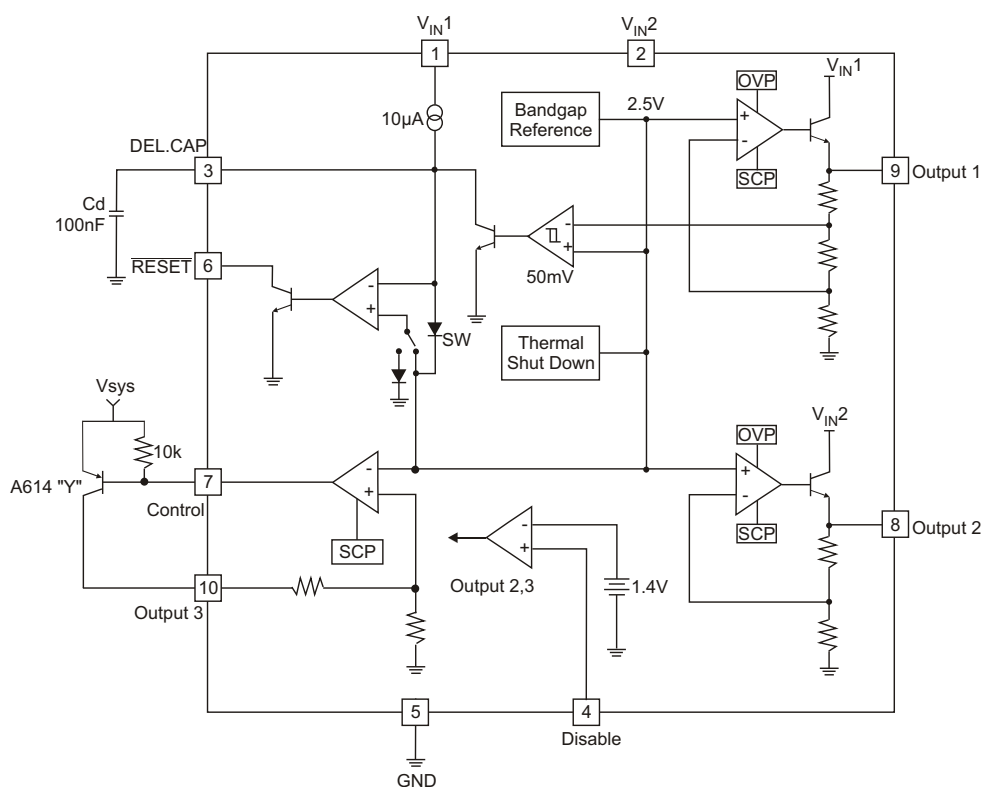

### ◆ ELECTRICAL CHARACTERISTICS

(Refer to test circuit  $V_{IN1}=6V$ ,  $V_{IN2}=10.5V$ ,  $T_J=25^{\circ}C$ , unless otherwise specified)

Parameter	Symbol	Condition	Min	Typ	Max	Unit
Output Voltage 1	$V_{O1}$	$I_{O1}=10mA$ , $6V < V_{IN1} < 14V$ $5mA < I_{O1} < 500mA$	3.22 3.14	3.3 3.3	3.38 3.46	V
Output Voltage 2	$V_{O2}$	$I_{O2}=10mA$ , $10.5V < V_{IN2} < 18V$ $5mA < I_{O2} < 500mA$	7.84 7.7	8 8	8.16 8.3	V
Dropout Output Voltage 1,2	$V_{d1,2}$	$I_{O1,2}=500mA$ ,	-	-	2.5	V
Line Regulation 1,2	$V_{O1,2}$	$6V < V_{IN1} < 14V$ $10.5V < V_{IN2} < 18V$ $I_{O1,2}=200mA$	-	-	40 80	mV
Load Regulation 1, 2	$V_{O1,2}$	$5mA < I_{O1} < 500mA$ $5mA < I_{O2} < 500mA$	-	0.1	70 160	mV
Output Voltage 3	$V_{O3}$	$V_{sys}=7V$ , $I_{O3}=100mA$	4.97	5.1	5.23	V
Line Regulation 3	$V_{O3}$	$13V < V_{IN3} < 18V$ $I_{O3}=100mA$	-	-	50	mV
Load Regulation 3	$V_{O3}$	$5mA < I_{O3} < 1A$	-	-	110	mV
Reset Pulse Delay	Trd	$C_d=100nF$ , Note 1	-	25	-	mS
Saturation Voltage in Reset Condition	VrL	$I_6=5mA$	-	-	0.4	V
Leakage Current Pin 6	IrH	$V_6=10V$	-	-	10	$\mu A$
Output Voltage Thermal Drift	Stt	$0^{\circ}C < T_J < +125^{\circ}C$ , Note 2	-	100	-	ppm/ $^{\circ}C$
Short Circuit Output Current	Isc 1,2	$V_{IN1}=6V$ , $V_{IN2}=10.5V$	-	-	1.6	A
Disable Voltage High	VdisH	Output 2 Active	2.0	-	-	V
Disable Voltage Low	VdisL	Output 2 Disabled	-	-	0.8	V
Disable Bias Current	Idis	$0V < V_{dis} < 7V$	-100	-	2	$\mu A$
Junction Temperature for TSD	Ttsd	Note 2	-	145	-	$^{\circ}C$
Quiescent Current	Iq	$I_{O1}=10mA$ , Output2 Disabled	-	-	2	mA
Reset Threshold Voltage	Vr	$K=V_{O1}$	K-0.4	K-0.25	K-0.1	V
Reset Threshold Hysteresis	Vrth	Note 1	20	50	100	mA

#### Notes:

1. To check the reset circuit, the reset output is low to discharge the delay capacitor(=Cd). if it's less than  $V_{O1}-0.25V$ . And the reset output is high when the delay capacitor voltage linearly increased by the internal current source( $10\mu A$ ) if it's more than  $V_{O1}-0.2V$ . The equations of delay time is same as below.  $Trd = (Cd \times 2.5) / 10\mu A$

2. Although guaranteed, these parameters are not 100% tested in production.

◆ TYPICAL PERFORMANCE CHARACTERISTICS

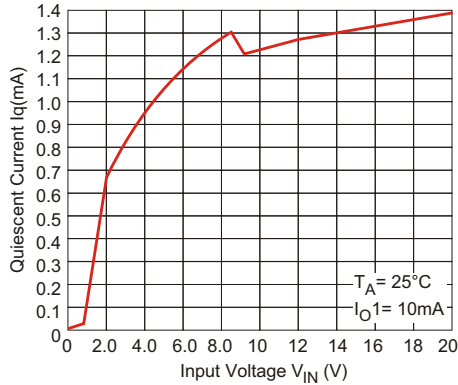

Figure 1. Quiescent Current vs. Input Voltage

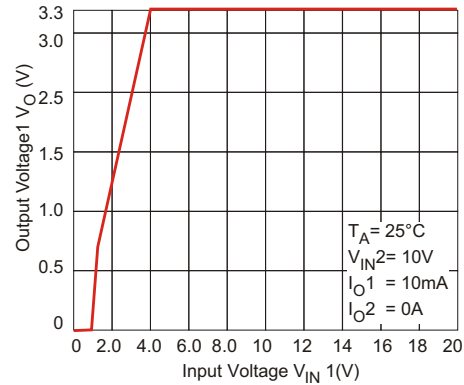

Figure 2. Output Voltage 1 vs. Input Voltage

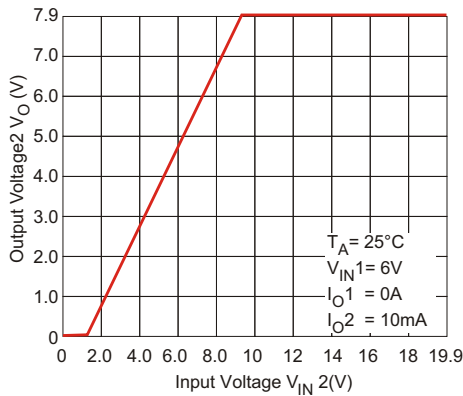

Figure 3. Output Voltage2 vs. Input Voltage

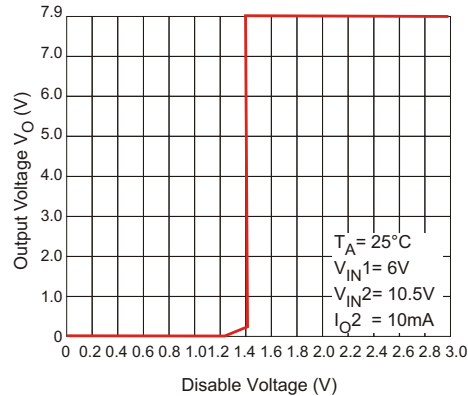

Figure 4. Output Voltage vs. Disable Voltage High (Low)

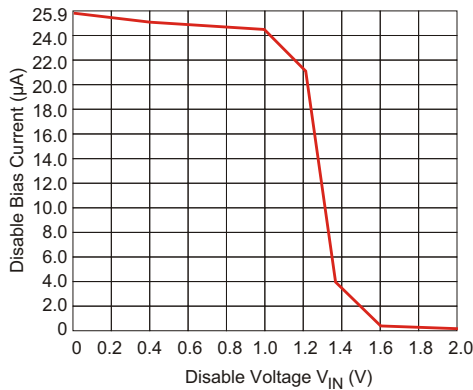

Figure 5. Disable Bias Current vs. Disable Voltage

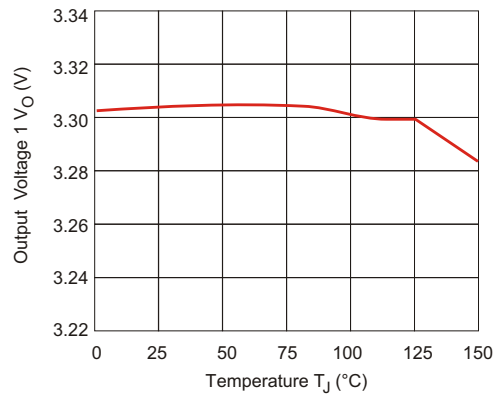

Figure 6. Output Voltage1 vs. Temperature ( $T_A = 0^{\circ} \sim 150^{\circ}$ )

◆ TYPICAL PERFORMANCE CHARACTERISTICS

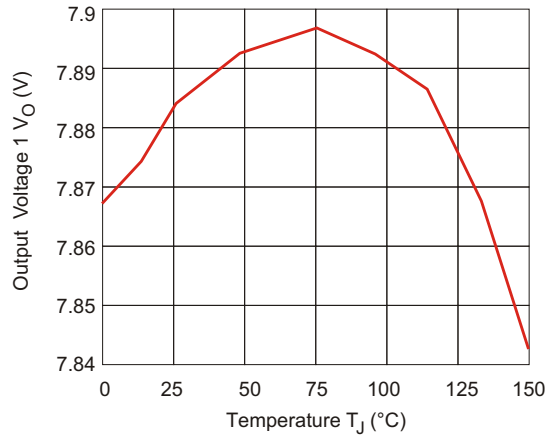
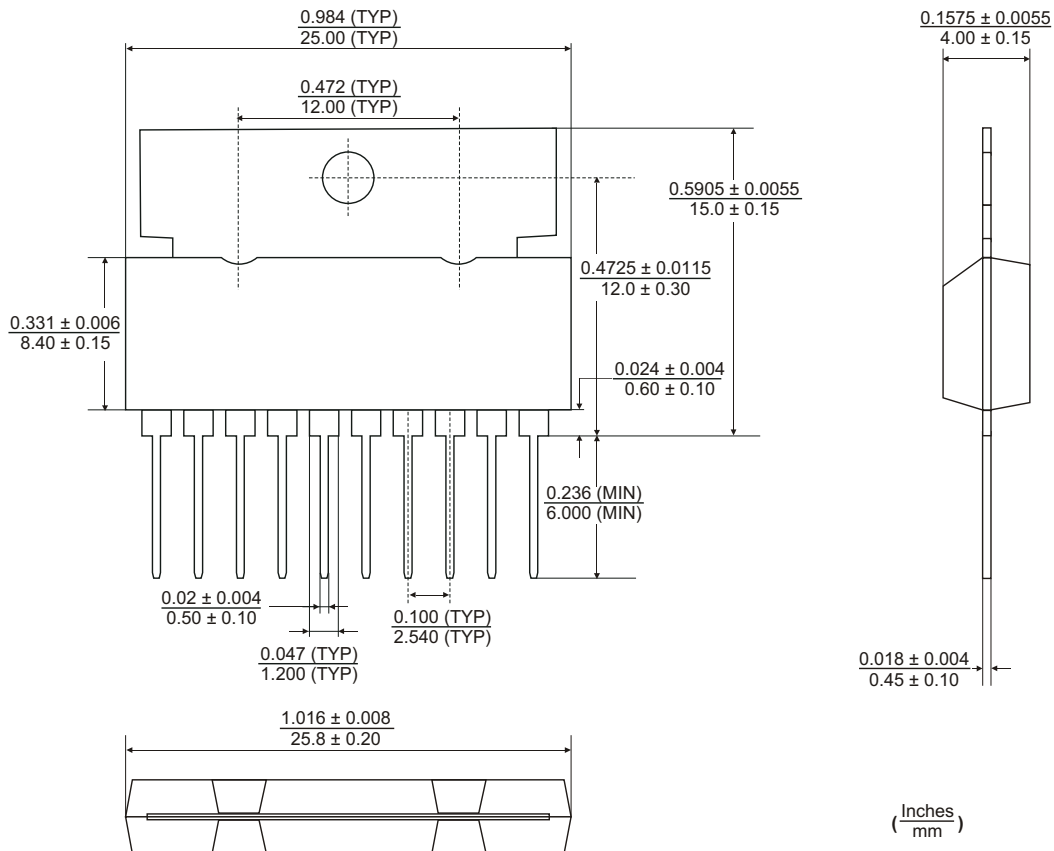

Figure 7. Output Voltage2 vs. Temperature (T<sub>A</sub> = 0° ~ 150°)

◆ 10-SIP H/S PACKAGE OUTLINE DIMENSIONS





GM7632

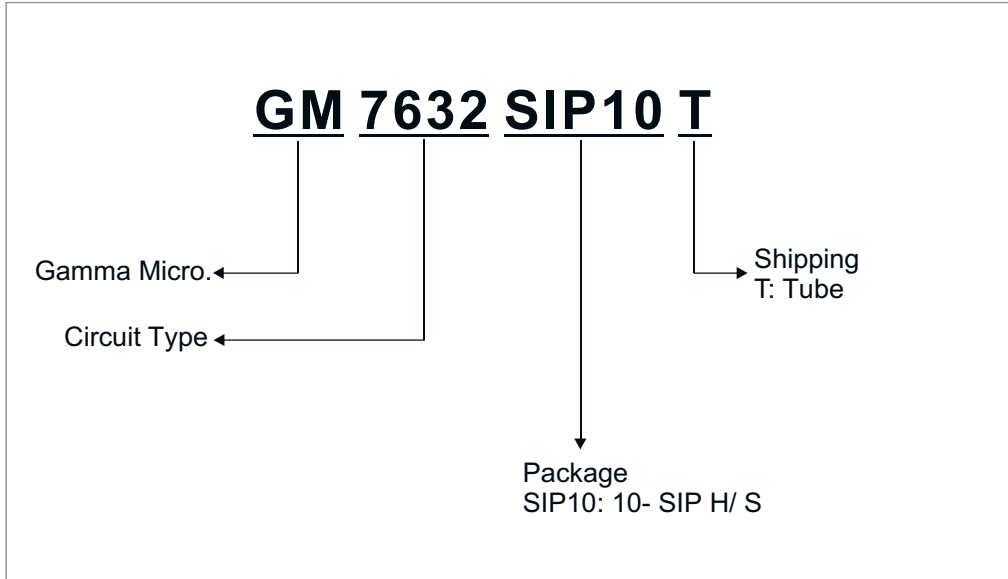

◆ ORDERING NUMBER



---

GAMMA Micro, , and  are registered trademarks of GAMMA MICROELECTRONICS INC. GAMMA reserves the right to make changes without further notice to any products herein. Information provided herein is alleged to be exact and consistent and this publication surpasses and replaces all information previously supplied.

GAMMA makes no warranty the suitability of its products for any particular purpose, nor does GAMMA assume any liability arising out of the application or use of any product or circuit, and specifically disclaims any and all liability including without limitation special, consequential or incidental damages.

GAMMA products are not authorized for using as critical components in life support devices or systems without prior written approval from GAMMA MICROELECTRONICS INC.

---