

Synchronous Boost DC/DC Regulator

General Description

The LP6202 is high efficiency synchronous, PWM step-up DC/DC converters optimized to provide a high efficiency solution to medium power system. the devices work under the input voltage between 0.9V and 4.4V with a 1.4 MHz fixed frequency switching. These features minimize overall solution footprint by allowing the use of tiny, low profile inductors and ceramic capacitors.

Ordering Information

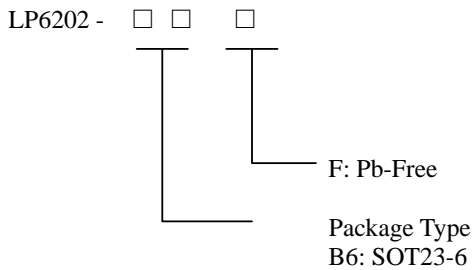

Features

- ◆ Up to 94% efficiency
- ◆ Low voltage start-up:0.9V
- ◆ Shut-down current:<1uA
- ◆ Output voltage:2.5-4.3V(Up to 5V with schottky)
- ◆ Low switch on resistance $R_{DS(ON)}$,Internal switch:0.35 OHM
- ◆ High switch on current:1A
- ◆ 1.4MHz fixed frequency switching
- ◆ Available in SOT23-6 Package

Pin Configurations

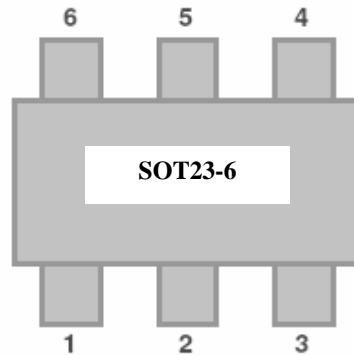

Typical Application Circuit

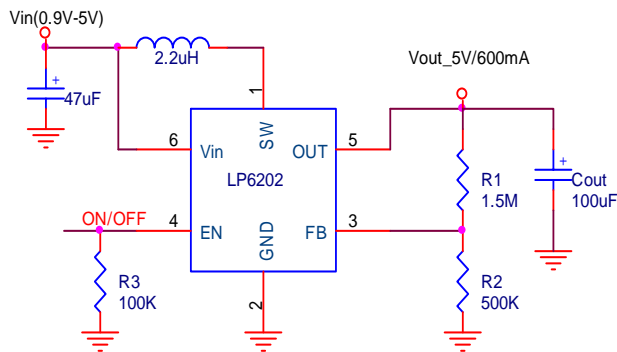

Applications

- ◇ AIK. Battery products

Marking Information

Please see website.

Functional Pin Description

PIN NUMBER SOT-23-6	PIN NAME	FUNCTION
1	SW	Switch Output
2	GND	Ground
3	FB	Feedback
4	EN	ON/OFF Control (High Enable)
5	V _{OUT}	Output
6	V _{IN}	Input

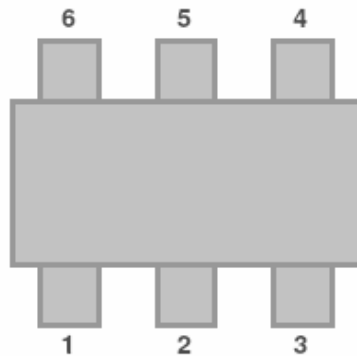

Function Block Diagram

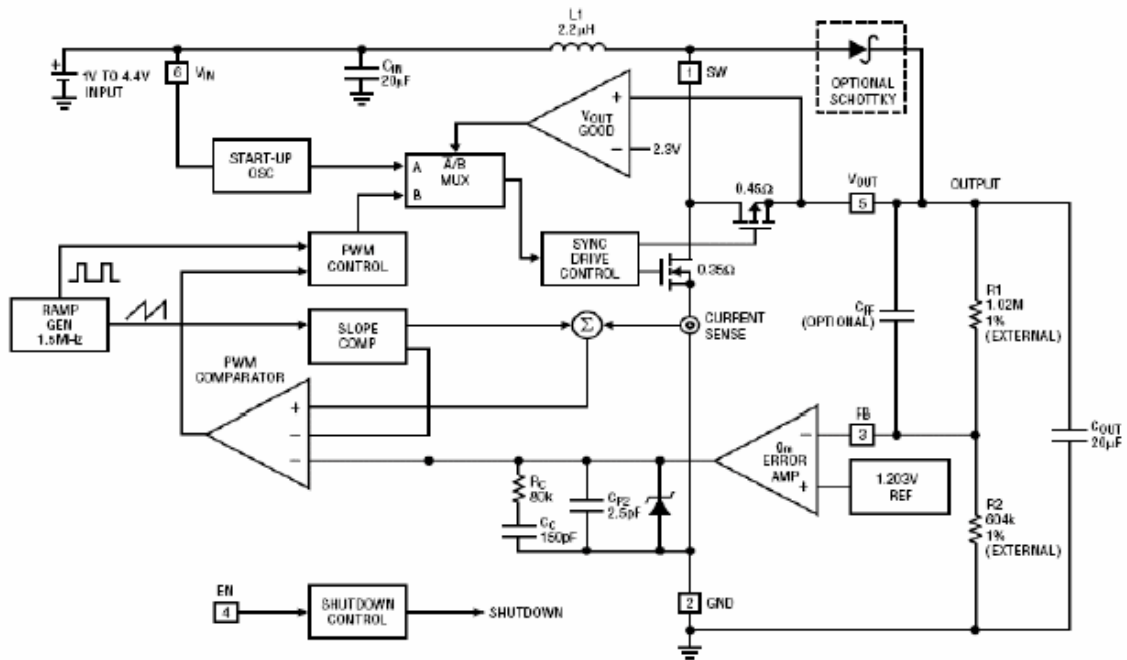

Absolute Maximum Ratings

Supply Input Voltage	-----6V
Power Dissipation, PD @ TA = 25° C	
SOT23-5	-----600mW
Package Thermal Resistance	
SOT23-5, θ_{JA}	-----250°C/W
Lead Temperature (Soldering, 10 sec.)	-----260°C
Storage Temperature Range	----- -65°C to 150°C
ESD Susceptibility	
HBM (Human Body Mode)	-----2kV
MM(Machine-Mode)	-----200V
Recommended Operating Conditions	
Supply Input Voltage	-----0.9V to 5.5V
EN Input Voltage	-----0V to 5.5V
Operation Junction Temperature Range	----- -40°C to 125°C
Operation Ambient Temperature Range	----- -40°C to 85°C

Electrical Characteristics

Operating Conditions: $T_A=25^{\circ}\text{C}$, $V_{IN}=1.2\text{V}$, $V_{OUT}=3.3\text{V}$ unless otherwise specified.

PARAMETER	CONDITIONS	MIN	TYP	MAX	UNITS
Output Voltage Range (Adj.)		2.5		5	V
Minimum Start-Up Voltage	$I_{LOAD} = 1\text{mA}$		0.9	1.1	V
Minimum Operating Voltage	$EN = V_{IN}$		0.6	0.75	V
Switching Frequency		1.1	1.4	1.7	MHz
Max Duty Cycle	$V_{FB} = 1.15\text{V}$	80	87		%
Current Limit Delay to Output			40		ns
Feedback Voltage		1.165	1.212	1.241	V
Feedback Input Current	$V_{FB} = 1.22\text{V}$		1		nA
NMOS Switch Leakage	$V_{SW} = 5\text{V}$		0.1	5	μA
PMOS Switch Leakage	$V_{SW} = 0\text{V}$		0.1	5	μA
NMOS Switch On Resistance	$V_{OUT} = 3.3\text{V}$		0.35		Ω
PMOS Switch On Resistance	$V_{OUT} = 3.3\text{V}$		0.45		Ω
NMOS Current Limit		700	950		mA
Quiescent Current (Active)	Measured On V_{OUT} , Nonswitching		300	500	μA
Shutdown Current	$V_{EN}=0\text{V}$, Including Switch Leakage		0.1	1	μA
En Input High		1			V
En Input Low				0.35	V
En Input Current	$V_{EN} = 5.5\text{V}$		0.01	1	μA

Typical Operating Characteristics

V_{OUT}=3.3V

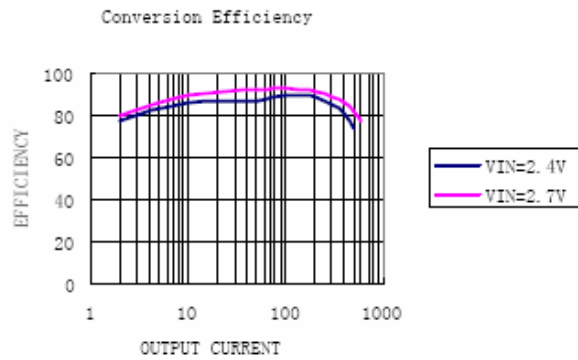
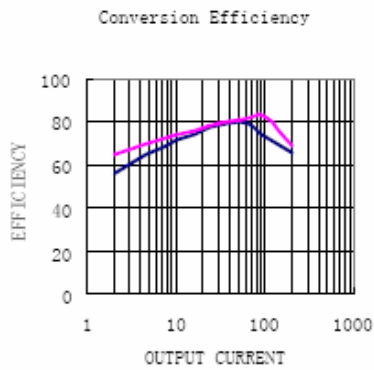
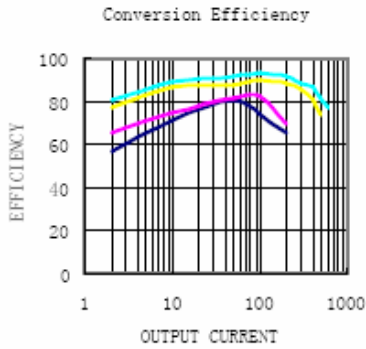

V_{OUT}=5V

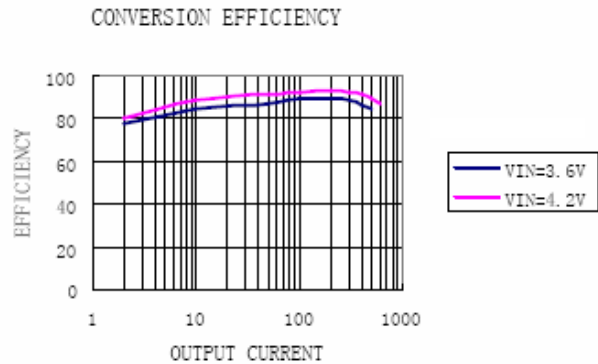
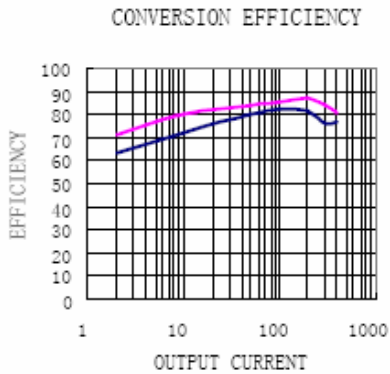

Packaging Information

SOT-23-6 Package Outline Dimension

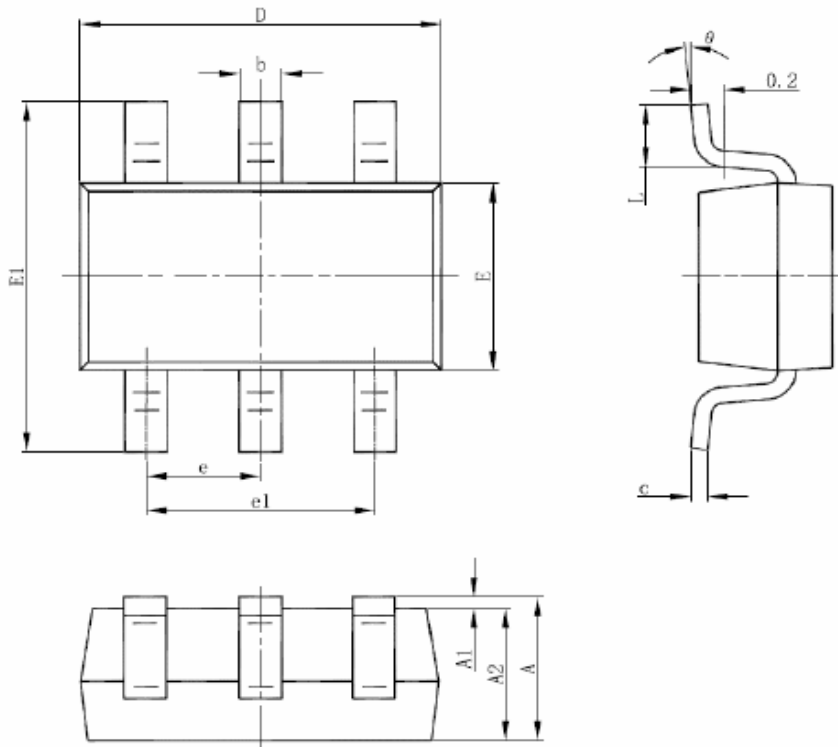

Symbol	Dimensions In Millimeters		Dimensions In Inches	
	Min	Max	Min	Max
A	1.050	1.250	0.041	0.049
A1	0.000	0.100	0.000	0.004
A2	1.050	1.150	0.041	0.045
b	0.300	0.500	0.012	0.020
c	0.100	0.200	0.004	0.008
D	2.820	3.020	0.111	0.119
E	1.500	1.700	0.059	0.067
E1	2.650	2.950	0.104	0.116
e	0.950(BSC)		0.037(BSC)	
e1	1.800	2.000	0.071	0.079
L	0.300	0.600	0.012	0.024
θ	0°	8°	0°	8°