

## Product Specification

### 10Gb/s 120km Telecom CML™ Transmitter Optical Sub-Assembly (TOSA)

DM80-02-0/1/2

#### PRODUCT FEATURES

- High Performance CML™
- Supports multi-bit-rate application, from 9.95Gb/s to 11.1Gb/s
- Supports link length up to 120km without DCM
- 4-7dBm modulated output power
- Case temperature range -5°C to 75°C
- Supports application with and without FEC
- TDM, DWDM single channel
- Covers ITU-T C- and L-band channels (1527.773nm to 1605.744nm)



#### APPLICATIONS

- Metro, Regional and Long haul DWDM application
- SONET/SDH OC-192, STM-64
- 10G Ethernet
- 10X Fibre Channel
- XFP, X2, Xenpak

Finisar's DM80-02 transmitter optical sub-assembly (TOSA) employs proprietary Chirp Managed Laser (CML™) technology and has been specifically designed to transmit 10Gb/s data over physical distances up to 120km. The module is comprised of a directly-modulated DFB laser chip and a co-packaged proprietary optical spectrum reshaper (OSR) passive optical element. The OSR component also provides a frequency locking function and allows operation on the ITU-T channels within  $\pm 2.5\text{GHz}$  with coverage across both C-band and L-band for DWDM versions. Also included in this TOSA package are 2 photo-detectors for power control and wavelength locking, together with 2 TECs for temperature stabilization. The miniature size of this TOSA ensures it suitable for integration into XFP, X2, Xenpak and other transceiver modules. Key specifications for the optical and electrical characteristics, physical requirements, environmental conditions and reliability/quality requirements are detailed in this document.

**Note:** Long version of this document with more detailed optical and electrical parameter specification is available upon request.

## I. Internal Optical Layout

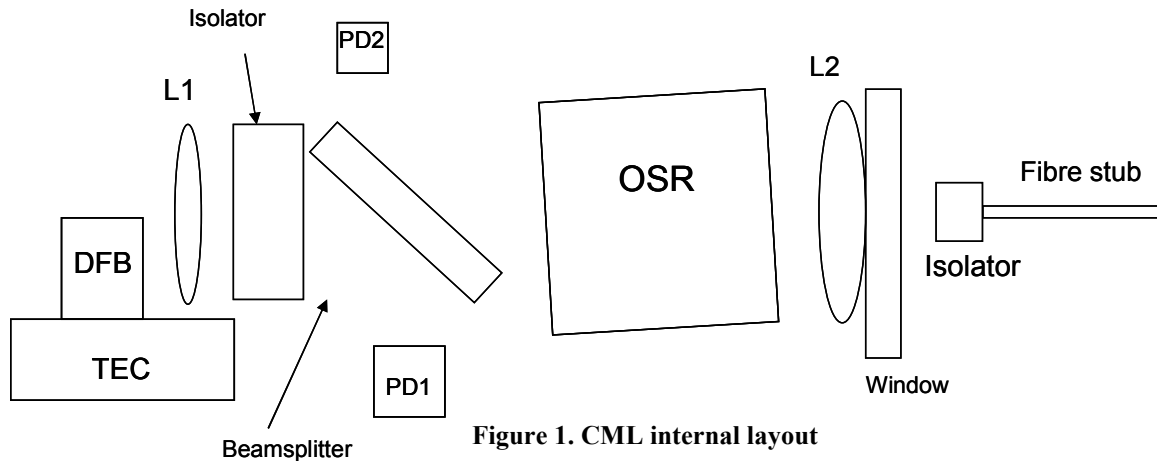

Figure 1. CML internal layout

The DM80-02 modules use a 10Gb/s directly modulated DFB chip co-packaged with an optical spectral re-shaper (OSR) element as shown in Figure 1. An optical isolator is included between the DFB and the OSR while a beam-splitter component and 2 photodetectors are configured to allow frequency locking. Lens#1(L1) is used to collimate the DFB laser output and pass the beam through the splitter and OSR, prior to coupling into single-mode fiber using Lens#2 (L2). A second isolator is included in the fiber pigtail to minimize the effect of external back-reflections on module performance.

## II. Control Method

The schematic in Figure 2 shows the key components and control loops that are used to operate the module. The output power of the DFB is monitored by photodetector PD1. Photodetector PD2 monitors the back-reflection from the OSR. The photocurrent ratio from the two detectors is used to lock the relative spectral locations of the laser and the OSR via temperature control of the DFB using TEC#1. A second TEC (TEC#2) controls the temperature of the OSR and locates the operating point of the OSR on the ITU grid for DWDM applications.

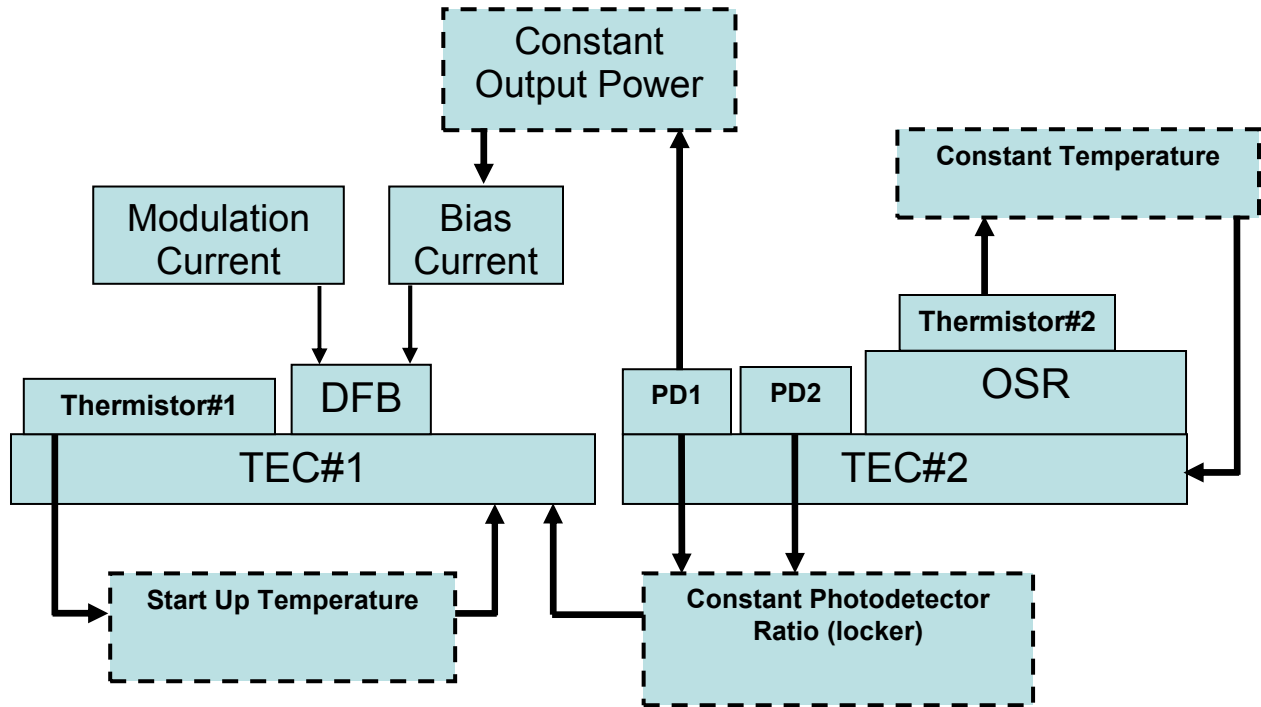

Figure 2: Control schematic for DM80-02 Module

### III. Absolute Maximum Ratings

Table 1: Absolute maximum ratings

Item	Parameters	Conditions	Min	Max	Units
1.	Storage Temperature		-40	85	°C
2.	Heat Soldering Temperature	on leads, 6 seconds max		260	°C
3.	Returned Fiber Power	CW, 1 second transient		13	dBm
4.	Laser Forward Current	Peak		200	mA
5.	Laser Reverse Voltage	Peak		2	V
6.	PD Forward Current	CW		1	mA
7.	PD Reverse Voltage	CW		2	V
8.	TEC Current	DC	-1.9	1.9	A
9.	TEC Voltage	DC		1.8	V
10.	Transient Cooler Current	1 sec	-1.9	1.9	A
11.	Tolerable External Reflection			-14	dB
12.	Optical Return Loss			-27	dB

## IV. Standard Operating Specifications

**Table 2: Standard Operating Requirements**

Item	Parameters	Min	Typ	Max	Units	Comments
1.	Bit Rate		9.953/10.7	11.1	Gb/s	All the following transmission parameters are tested at 9.95 or 10.7Gb/s
2.	Operating Case Temperature Range	-5		75	°C	
3.	Wavelength (SOL)		ITU-T Grid		GHz	ITU-T wavelength grids defined in Tables 9 & 10
4.	Locked deviation from ITU	-2.5		2.5	GHz	EOLOT
5.	Modulated Output Power (EOL)	4		7	dBm	SOL operation condition to be discussed.
6.	Operating Drive current (SOL)	70		100	mA	
7.	Allowed Deviation from SOL drive current over life and temperature	-15		20	%	
8.	Required Resolution of Operating Drive Current			0.09	mA	360mA/4096 levels
9.	SMSR	35	40		dB	
10.	Wavelength temperature tuning coefficient		0.1		nm/°C	
11.	Wavelength current tuning coefficient		7		pm/mA	
12.	Laser threshold current			25	mA	
13.	Forward Bias Voltage			1.8	V	
14.	RIN			-135	dB/Hz	0 to 10 GHz, Measured before OSR is installed
15.	Laser CW Linewidth (FWHM)		2	10	MHz	Measured before OSR
16.	Module Input Impedance		50		Ohms	Recommend use of EML driver technology
17.	Peak to Peak voltage, Vpp	1.2	1.8	2.5	V	Into 50ohm
18.	Electrical input crossing	25		80	%	Customer must provide adjustment capability on electrical driver
19.	Extinction Ratio (EOLOT)	9			dB	BT Filter OFF
20.	Optical crossing	tbc		tbc	%	BT Filter OFF
21.	S11	Mask			dB	tbc
22.	S21 (3dB BW)	10			GHz	Before OSR
23.	Power dispersion Penalty @ 30dB OSNR, 9.95Gbs,			2	dB	Receiver threshold optimized for

	BER=10 <sup>-12</sup> , 1600ps/nm (EOLOT) <sup>1</sup>					transmission, to be discussed
24.	OSNR dispersion Penalty @ BER=10 <sup>-4</sup> , 10.7Gbs, 1600ps/nm (EOLOT) <sup>1</sup>			2	dB	Receiver threshold optimized at BB and 1600ps/nm

**Note:**

1. Please call Finisar to discuss the receiver configuration, including types of PIN/APD, and power level into APD, and the type of CDRs are used. 2400ps/nm transmission is possible with trade-off between back-to-back eye diagram and transmission performance; DM80-01 is also compliant with the newly accepted ITU 10Gbps 120km standard P1V1-2C2

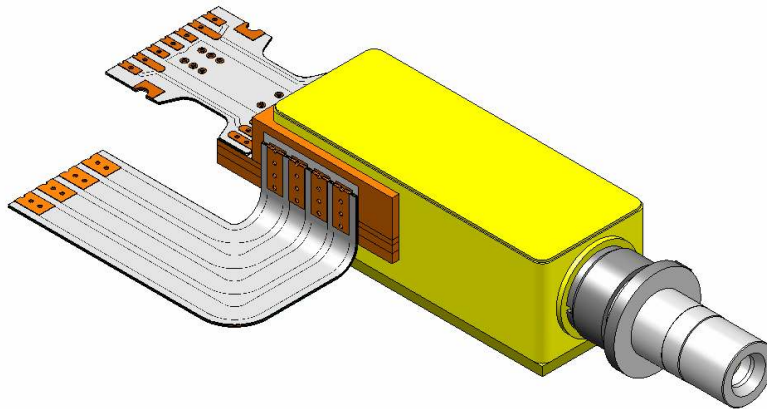
**V. Mechanical Details****Figure 3: TOSA Package Profile**

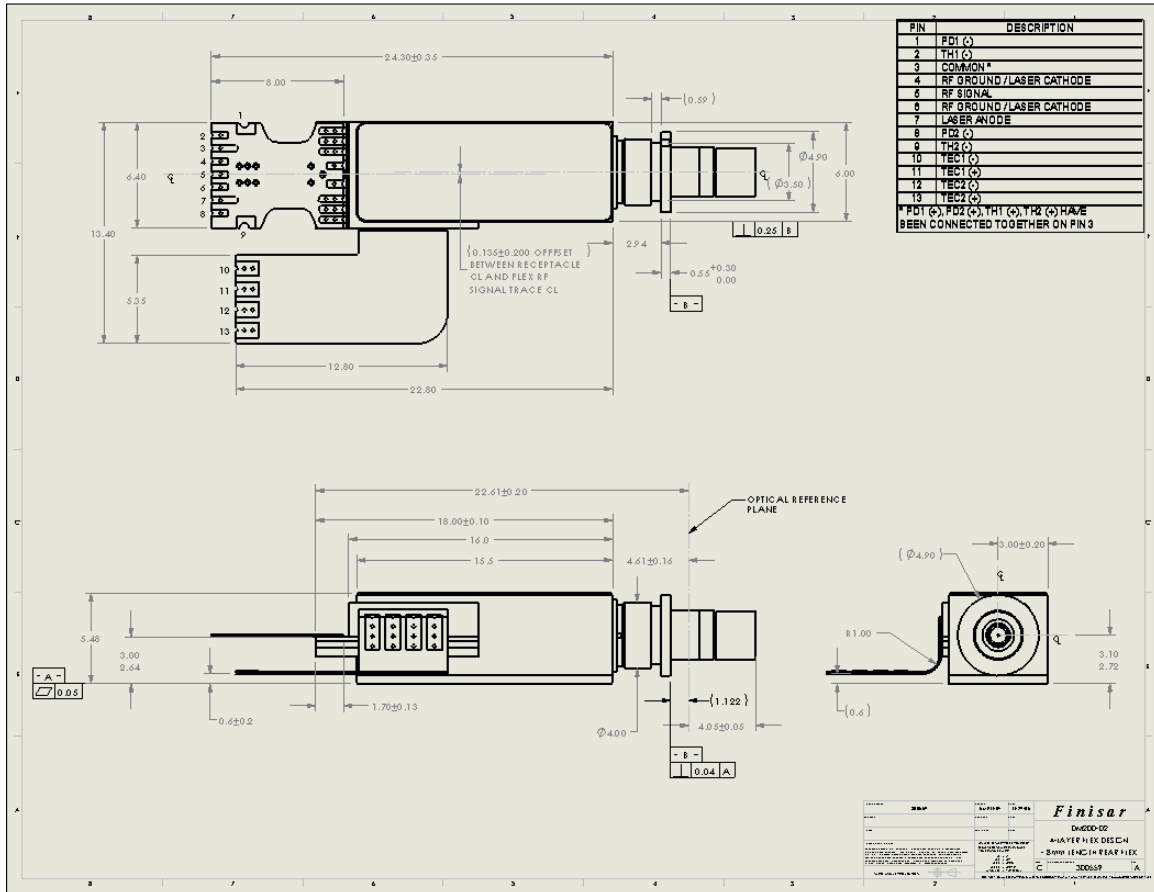

Figure 4: TOSA Package Outline Dimensions

### V.1 Flex Cables and Signal Connections

This TOSA has 2 flex cables. The rear flex cable has 9 connections including a high speed ground-signal-ground coplanar waveguide, located in the middle of the cable, for delivery of high speed data signals. The side flex has 4 connections for high current TEC signals.

Table 8: Signal Connection Description

Pin	Description
1.	PD1 (-)
2.	Thermistor#1 (-)
3.	Common
4.	RF Ground/Laser Cathode
5.	RF Signal
6.	RF Ground/Laser Cathode
7.	Laser Anode for Bias Current
8.	PD2 (-)
9.	Thermistor#2 (-)
10.	TEC 1 (-)

11.	TEC 1 (+)
12.	TEC 2 (-)
13.	TEC 2 (+)

## V.2 Connector Options

LC receptable is currently. SC receptable is possible. Please contact Finisar for request.

## V.3 10Gb/s Signal Delivery - RF Connection

The RF connection is through the ground-signal-ground coplanar structure on the rear flex cable.

## VI. Wavelength Coverage

**Table 4: DWDM Product Identification C-Band 100 GHz**

	Channel ID	Frequency (GHz)	Wavelength (nm)	Channel ID	Frequency (GHz)	Wavelength (nm)
C-band	9170	191700	1563.863	9400	194000	1545.322
	9180	191800	1563.047	9410	194100	1544.526
	9190	191900	1562.233	9420	194200	1543.73
	9200	192000	1561.419	9430	194300	1542.936
	9210	192100	1560.606	9440	194400	1542.142
	9220	192200	1559.794	9450	194500	1541.349
	9230	192300	1558.983	9460	194600	1540.557
	9240	192400	1558.173	9470	194700	1539.766
	9250	192500	1557.363	9480	194800	1538.976
	9260	192600	1556.555	9490	194900	1538.186
	9270	192700	1555.747	9500	195000	1537.397
	9280	192800	1554.94	9510	195100	1536.609
	9290	192900	1554.134	9520	195200	1535.822
	9300	193000	1553.329	9530	195300	1535.036
	9310	193100	1552.524	9540	195400	1534.25
	9320	193200	1551.721	9550	195500	1533.465
	9330	193300	1550.918	9560	195600	1532.681
	9340	193400	1550.116	9570	195700	1531.898
	9350	193500	1549.315	9580	195800	1531.116
	9360	193600	1548.515	9590	195900	1530.334
9370	193700	1547.715	9600	196000	1529.553	
9380	193800	1546.917	9610	196100	1528.773	
9390	193900	1546.119				

**Table 5: DWDM Product Identification L-Band 100 GHz**

	<b>Channel ID</b>	<b>Frequency (GHz)</b>	<b>Wavelength (nm)</b>	<b>Channel ID</b>	<b>Frequency (GHz)</b>	<b>Wavelength (nm)</b>
<b>L-band</b>	8670	186700	1605.744	8920	189200	1584.527
	8680	186800	1604.885	8930	189300	1583.69
	8690	186900	1604.026	8940	189400	1582.854
	8700	187000	1603.168	8950	189500	1582.018
	8710	187100	1602.311	8960	189600	1581.184
	8720	187200	1601.455	8970	189700	1580.35
	8730	187300	1600.6	8980	189800	1579.518
	8740	187400	1599.746	8990	189900	1578.686
	8750	187500	1598.893	9000	190000	1577.855
	8760	187600	1598.041	9010	190100	1577.025
	8770	187700	1597.189	9020	190200	1576.196
	8780	187800	1596.339	9030	190300	1575.368
	8790	187900	1595.489	9040	190400	1574.54
	8800	188000	1594.641	9050	190500	1573.714
	8810	188100	1593.793	9060	190600	1572.888
	8820	188200	1592.946	9070	190700	1572.063
	8830	188300	1592.1	9080	190800	1571.239
	8840	188400	1591.255	9090	190900	1570.416
	8850	188500	1590.411	9100	19100	1569.594
	8860	188600	1589.568	9110	191100	1568.773
8870	188700	1588.725	9120	191200	1567.952	
8880	188800	1587.884	9130	191300	1567.133	
8890	188900	1587.043	9140	191400	1566.314	
8900	189000	1586.203	9150	191500	1565.496	
8910	189100	1585.365	9160	191600	1564.679	

## VII. Quality and Reliability

### Lifetime

The operating lifetime of the module is 15 years. The reliability target is 400 FITs mean over 15 years to include random and wear out failures, valid for high-end of case temperature range. All specifications apply over this period of time.

### Qualification

The DM80-02 module is being qualified in accordance with the Telcordia standard GR-468-CORE. The qualification report will be available upon request once the qualification test is completed.



**Electro-Static Discharge (ESD)**

The device meets the ESD Class 3 requirements of the Telcordia standard TR-NWT-000870 Issue 1, dated February 1991.

**VIII. Order Information****Product code**

For the product specified in this document, the proper product code shall be:

DM80-02-1 (or, -0, -2)-xxxx-3-RC-yyyy

This product code should be specified when placing a purchase order.

- “01” indicates a butterfly box module as specified in this document.
- “1” indicates the laser wavelength will be specified on 100GHz ITU grid as specified in Table 9 and Table 10. If –“0” is specified, it can be a TDM version with any wavelength within C or L band, but not guaranteed on ITU grids. –“2” can also be specified for 50GHz ITU grid.
- “xxxx” is the channel ID as specified in Table 9 and Table 10.
- “3” indicates modulated output power range is between 4-7dBm. Please contact Finisar if different power level is needed.
- “RC” indicates the optical connector type is a receptacle, currently an LC receptacle. If other type connector is required, please contact Finisar.
- “yyyy” indicates any special customized request and need to be agreed with Finisar prior to ordering

**IX. Revision History**

Revision	Date	Description
A	5-May-2007	• Document created.
		•
		•
		•
		•
		•
		•
		•
		•

## **X. For More Information**

Finisar Corporation  
1389 Moffett Park Drive  
Sunnyvale, CA 94089-1133  
Tel. 1-408-548-1000  
Fax 1-408-541-6138  
[sales@finisar.com](mailto:sales@finisar.com)  
[www.finisar.com](http://www.finisar.com)