

**Features**

- 4:1 multiplexer with monitor out
- DC-restore amplifier
- $\pm 5V$  operation
- 500MHz bandwidth

**Applications**

- HDTV/DTV analog inputs
- Video projectors
- Computer monitors
- Set top boxes
- Security video
- Broadcast video equipment

**Ordering Information**

Part No.	Package	Tape & Reel	Outline #
EL4101CU	24-Pin QSOP		MDP0040

**General Description**

The EL4101C VFE (Video Front End) is designed to perform the basic input processing functions in an analog video system as well as provide analog input processing for digital video systems. The EL4101C VFE contains a 4:1 MUX input and a DC-restore amplifier. The MUX input can be used to select which input to use. The DC-restore allows the input signal to be positioned to the correct voltage level for either analog or digital processing. A buffered output of the MUX selection is also available for use as a monitor output.

With a 500MHz bandwidth and only 40mA supply current, the EL4101C is ideal for use in portable and fixed projectors, as well as HDTV, DTV and other high performance video applications.

The EL4101C is available in the 24-pin QSOP package and is specified for operation over the full  $-40^{\circ}C$  to  $+85^{\circ}C$  temperature range.

**Connection Diagram**

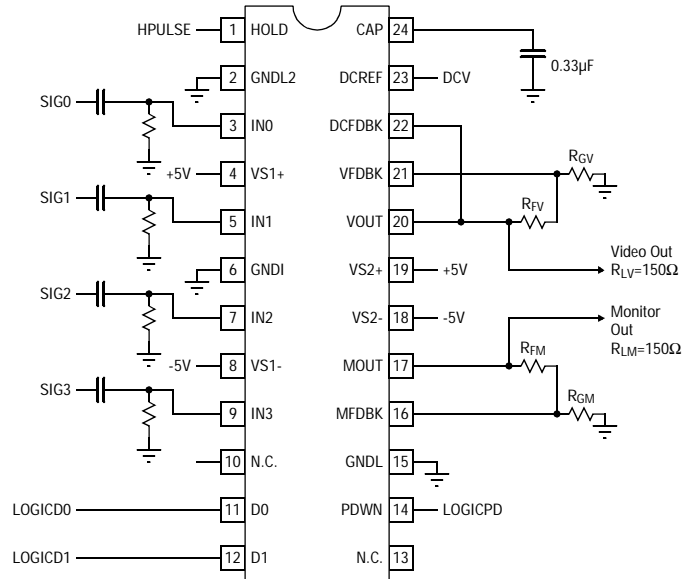

Note: Pin #6 should be a good high frequency ground

Note: All information contained in this data sheet has been carefully checked and is believed to be accurate as of the date of publication; however, this data sheet cannot be a "controlled document". Current revisions, if any, to these specifications are maintained at the factory and are available upon your request. We recommend checking the revision level before finalization of your design documentation.

# EL4101C - Preliminary

## 500MHz Video Front End - 4:1MUX + DC-Restore

### Absolute Maximum Ratings (T<sub>A</sub> = 25°C)

Values beyond absolute maximum ratings can cause the device to be prematurely damaged. Absolute maximum ratings are stress ratings only and functional device operation is not implied.

Supply Voltage (V<sub>S+</sub> to V<sub>S-</sub>) 11V  
 Input Voltage V<sub>S-</sub> - 0.3V, V<sub>S+</sub> +0.3V

Storage Temperature Range -65°C to +150°C  
 Ambient operating Temperature -40°C to +85°C  
 Operating Junction Temperature 125°C  
 Power Dissipation See Curves

#### Important Note:

All parameters having Min/Max specifications are guaranteed. Typ values are for information purposes only. Unless otherwise noted, all tests are at the specified temperature and are pulsed tests, therefore: T<sub>J</sub> = T<sub>C</sub> = T<sub>A</sub>.

### Electrical Characteristics

V<sub>S1+</sub> = V<sub>S2+</sub> = 5V, V<sub>S1-</sub> = V<sub>S2-</sub> = -5V, R<sub>FV</sub> = R<sub>GV</sub> = R<sub>FM</sub> = R<sub>GM</sub> = 375, R<sub>LV</sub> = R<sub>LM</sub> = 150Ω, C<sub>LV</sub> = C<sub>LM</sub> = 3p, C<sub>H</sub> = 0.33n, GAIN = 2.

Parameter	Parameter Description	Conditions	Min	Typ	Max	Unit
<b>Supply</b>						
I <sub>S1+</sub>	Positive Supply Current 1			25		mA
I <sub>S-</sub>	Negative Supply Current			38		mA
I <sub>S2+</sub>	Positive Supply Current 2	V <sub>IN</sub> = 0, I <sub>L</sub> = 0		15		mA
I <sub>S1S+</sub>	Positive Supply Current 1 in Standby	Standby		3.8		mA
I <sub>SS-</sub>	Negative Supply Current in Standby	Standby		2		mA
I <sub>S2S+</sub>	Positive Supply Current 2 in Standby	Standby		236		μA
<b>Input</b>						
I <sub>B</sub>	Input Bias Current	V <sub>IN</sub> = 0V	-22.4	-2.2	6.1	μA
I <sub>BO</sub>	Input Bias Current Drift with Temp.	V <sub>IN</sub> = 0V		TBD		nA/°C
V <sub>IH</sub>	Input High Voltage		2			V
V <sub>IL</sub>	Input Low Voltage				0.8	V
I <sub>IL</sub>	Low Input Current for D0, D1, PDWN, HOLD	V <sub>IN</sub> = 0V	25	48	75	μA
I <sub>IH</sub>	High Input Current for D0, D1, PDWN, HOLD	V <sub>IN</sub> = 5V	0	-	10	μA
t <sub>SH</sub>	Sample and Hold Delay Time			12		ns
<b>Output</b>						
V <sub>OSM</sub>	Output Offset Voltage - Monitor	V <sub>IN</sub> = 0V	-400	18	420	mV
V <sub>OS</sub>	DC-restore Offset Voltage	Auto-zero on, DC <sub>REF</sub> = 0	-5	-	5	mV
δV <sub>OS</sub>	Output Offset Voltage Drift - Video	Auto-zero on		TBD		μV/°C
V <sub>OH</sub>	Output Voltage Swing, Pos.	A <sub>V</sub> = +1, monitor & video outputs	3.44	3.5		V
V <sub>OL</sub>	Output Voltage Swing, Neg.	A <sub>V</sub> = +1, monitor & video outputs	-3.43	-3.5		V
I <sub>SC</sub>	Output Short Circuit Current	R <sub>L</sub> = 10Ω, source or sink	65	100	140	mA
<b>AC Performance</b>						
SR	Slew Rate - Video Out (20%-80%)	V <sub>OUT</sub> = 4V <sub>P-P</sub>	1000	2100	4500	V/μs
SRM	Slew Rate - Monitor Out (20%-80%)	V <sub>OUT</sub> = 4V <sub>P-P</sub>	1250	2100	3900	V/μs
OS	Output Overshoot, Video	V <sub>OUT</sub> = 1V <sub>P-P</sub>		TBD		%
OSM	Output Overshoot, Monitor	V <sub>OUT</sub> = 1V <sub>P-P</sub>		TBD		%
t <sub>S</sub>	Settling Time to 1%, Video	Hold mode		10		ns
t <sub>SM</sub>	Settling Time to 1%, Monitor			10		ns
V <sub>REF</sub>	DC-restore -Reference Voltage Range	V <sub>IN</sub> = -2V to +2V	-2	-	2	V
t <sub>SD</sub>	DC-restore - Settling Time to 1%	Sample mode on		2.5		μs
V <sub>OHS</sub>	DC-restore - Video Output Hold Step	S - H transition		-0.5		mV
V <sub>OSB</sub>	DC-restore - Offset vs. Black Level	Sample mode on	-1	-0.6	1	mV/V
I <sub>CC</sub>	DC-restore - Charge Current Limit, I <sub>CAP</sub>	Sample mode on	210	260	345	μA
I <sub>DC</sub>	DC-restore - Droop Current, I <sub>CAP</sub>	Hold mode on	-30	-	30	nA

# EL4101C - Preliminary

## 500MHz Video Front End - 4:1MUX + DC-Restore

EL4101C - Preliminary

### Electrical Characteristics

$V_{S1+} = V_{S2+} = 5V$ ,  $V_{S1-} = V_{S2-} = -5V$ ,  $R_{FV} = R_{GV} = R_{FM} = R_{GM} = 375$ ,  $R_{LV} = R_{LM} = 150\Omega$ ,  $C_{LV} = C_{LM} = 3p$ ,  $C_H = 0.33n$ ,  $GAIN = 2$ .

Parameter	Parameter Description	Conditions	Min	Typ	Max	Unit
BW	3dB Bandwidth, Video Out			500		MHz
BWM	3dB Bandwidth, Monitor Out			1000		MHz
0.1BW	$\pm 0.1dB$ Flat Bandwidth, Video Out			25		MHz
0.1BWM	$\pm 0.1dB$ Flat Bandwidth, Monitor Out			18		MHz
Vp	Peaking, Video			2.4		dB
Vpm	Peaking, Monitor			4.5		dB
dP	Diff. Phase @3.58MHz, Video			TBD		°
dG	Diff. Gain @3.58MHz, Video			TBD		%
dPM	Diff. Phase @3.58MHz, Monitor			TBD		°
dPG	Diff. Gain @3.58MHz, Monitor			TBD		%
e <sub>n</sub>	Noise Voltage at Input for VOUT			TBD		nV/√Hz
e <sub>nm</sub>	Noise Voltage at Input for MOUT			TBD		nV/√Hz
	Crosstalk <sup>[1]</sup> @10MHz	3 channel hostile		-45		dB
	Crosstalk <sup>[1]</sup> @100MHz	3 channel hostile		-20		dB

1. Total unwanted output normalized by wanted (or expected) output; add -10dB to get channel-to-channel isolation

### Parallel Programming Truth Table

Inputs			State
PDWN	D1	D0	
0	0	0	IN0 Selected
0	0	1	IN1 Selected
0	1	0	IN2 Selected
0	1	1	IN3 Selected
1	X	X	Standby - Powered Down

**EL4101C - Preliminary****500MHz Video Front End - 4:1MUX + DC-Restore****Pin Descriptions**

Pin Number	Pin Name	Pin Type	Pin Description
1	HOLD	Logic Input	Hold pulse for DC-restore function
2	GNDL2	Logic Ground	Logic ground for "hold" buffer
3	IN0	High Frequency Signal	Video input #0
4	VS1+	Power	Positive power pin for quiet supply currents
5	IN1	High Frequency Signal	Video input #1
6	GND1	Analog Signal	Reference voltage for attenuation function
7	IN2	High Frequency Signal	Video input #2
8	VS1-	Power	Negative power pin for quiet supply currents
9	IN3	High Frequency Signal	Video input #3
10			No connection
11	D0	Logic Input	Parallel control bit #0
12	D1	Logic Input	Parallel control bit #1
13			No connection
14	PDWN	Logic Input	Power down input to put chip in low current standby mode
15	GNDL	Logic Ground	Logic ground for D0, D1, PWDN buffers
16	MFDBK	High Frequency Signal	Monitor amplifier feedback
17	MOUT	High Frequency Signal	Monitor amplifier output
18	VS2-	Power	Negative power pin for heavy, pulsatile supply currents
19	VS2+	Power	Positive power pin for heavy, pulsatile supply currents
20	VOUT	High Frequency Signal	Video amplifier output
21	VFDBK	High Frequency Signal	Video amplifier feedback
22	DCFDBK	Analog Signal	Input to sample circuit
23	DCREF	Analog Signal	Reference DC voltage representing black level
24	CAP	Analog Signal	Sample storage capacitor for DC-restore circuit

# EL4101C - Preliminary

## 500MHz Video Front End - 4:1MUX + DC-Restore

EL4101C - Preliminary

### Typical Performance Curves

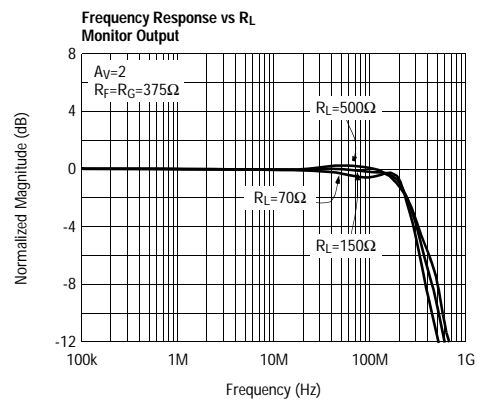
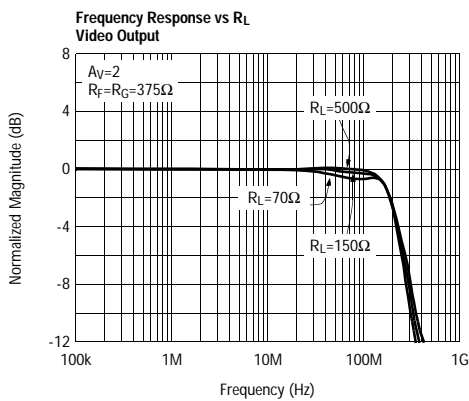
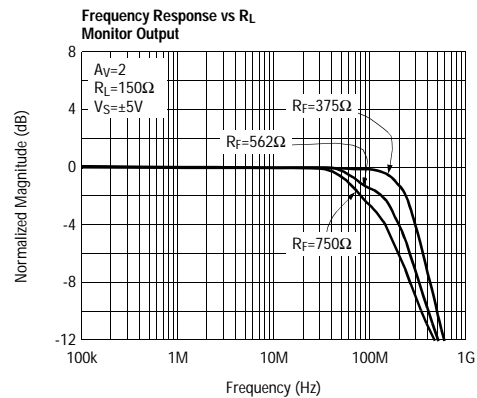
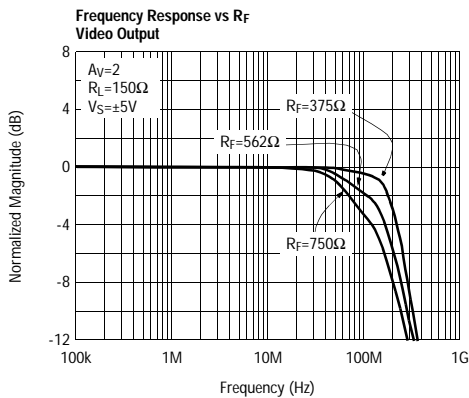
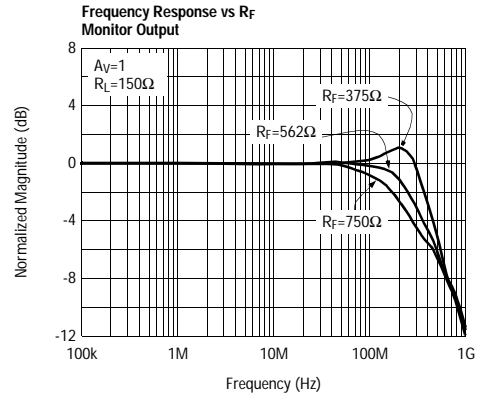
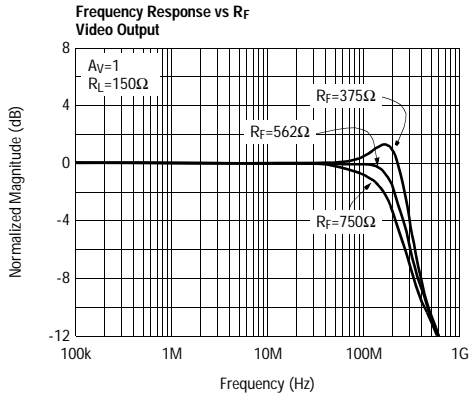

# EL4101C - Preliminary

500MHz Video Front End - 4:1MUX + DC-Restore

## Typical Performance Curves

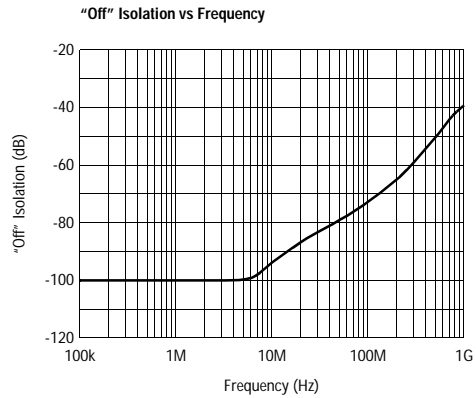
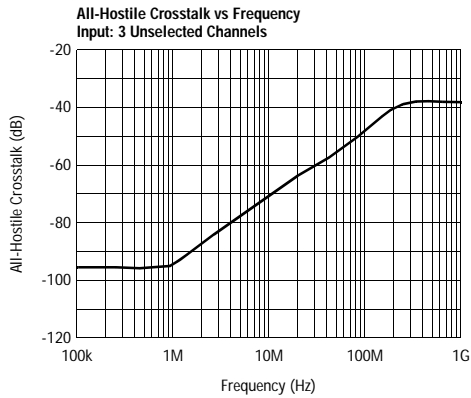
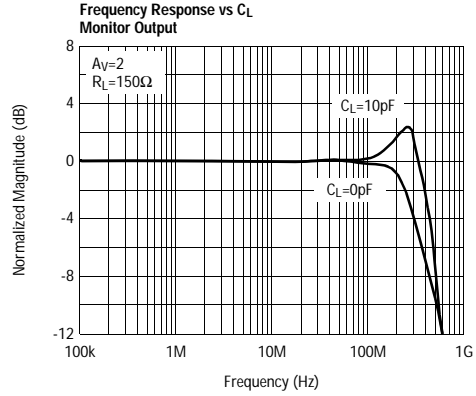
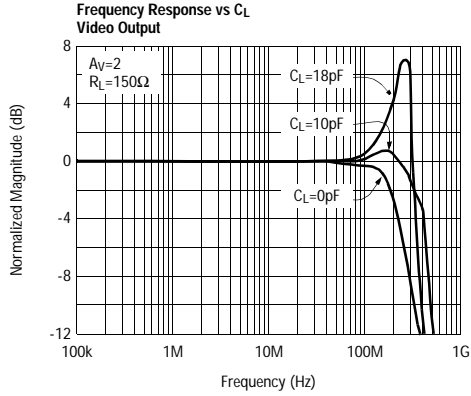

# EL4101C - Preliminary

500MHz Video Front End - 4:1MUX + DC-Restore

EL4101C - Preliminary

## Block Diagram (Gain of 1)

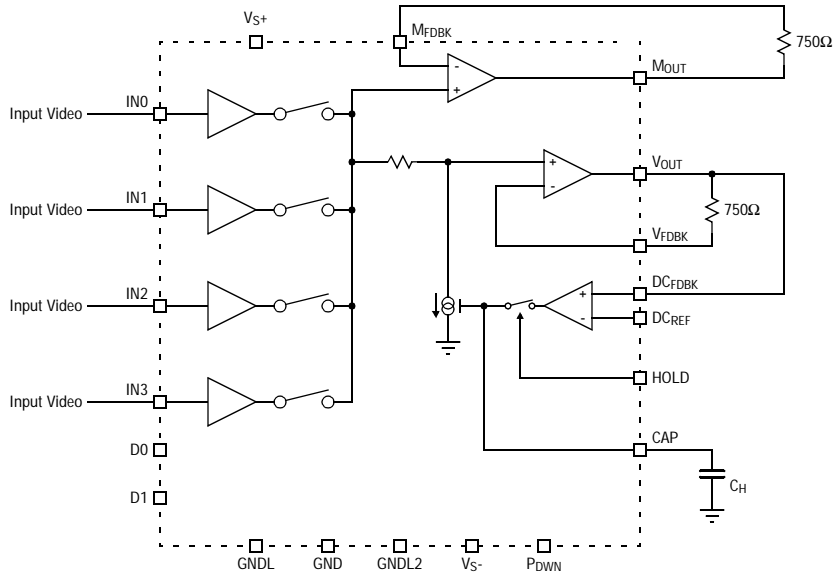

**EL4101C - Preliminary****500MHz Video Front End - 4:1MUX + DC-Restore****General Disclaimer**

Specifications contained in this data sheet are in effect as of the publication date shown. Elantec, Inc. reserves the right to make changes in the circuitry or specifications contained herein at any time without notice. Elantec, Inc. assumes no responsibility for the use of any circuits described herein and makes no representations that they are free from patent infringement.

**élantec**

HIGH PERFORMANCE ANALOG INTEGRATED CIRCUITS

**Elantec Semiconductor, Inc.**

675 Trade Zone Blvd.

Milpitas, CA 95035

Telephone: (408) 945-1323

(888) ELANTEC

Fax: (408) 945-9305

European Office: +44-118-977-6020

Japan Technical Center: +81-45-682-5820

**WARNING - Life Support Policy**

Elantec, Inc. products are not authorized for and should not be used within Life Support Systems without the specific written consent of Elantec, Inc. Life Support systems are equipment intended to support or sustain life and whose failure to perform when properly used in accordance with instructions provided can be reasonably expected to result in significant personal injury or death. Users contemplating application of Elantec, Inc. Products in Life Support Systems are requested to contact Elantec, Inc. factory headquarters to establish suitable terms & conditions for these applications. Elantec, Inc.'s warranty is limited to replacement of defective components and does not cover injury to persons or property or other consequential damages.