

SMD Zener Diode



SMD Diodes Specialist

CZRT5221B-G Thru CZRT5267B-G

Voltage: 2.4 to 39 Volts

Power: 350 mWatts

RoHS Device

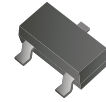

Features

- Planar die construction
- 350mW power dissipation on FR-4 PCB
- Ideally suited for automated assembly process
- General purpose, medium current

Mechanical data

- Case: SOT-23, Molded plastic
- Terminals: Solderable per MIL-STD-202G, method 208
- Polarity: See diagram below
- Mounting position: Any
- Marking: see table on page 2
- Weight: 0.0078 gram (approx.).

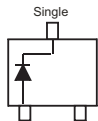
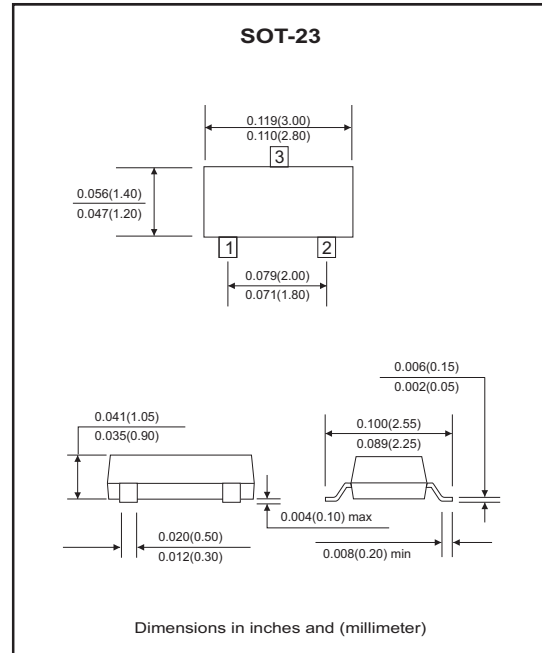

Electrical Characteristics (TA=25°C, unless otherwise specified)

Parameter	Symbol	Value	Unit
Forward voltage drop at IF=10mA	V _F	0.9	V
Power dissipation (Notes A), T _A = 25°C	P _D	350	mW
Thermal resistance, junction to ambient air (Notes A)	R _{θJA}	357	°C/W
Operating junction and storage temperature range	T _J	-65 to +150	°C

- Notes:
- A. Valid provided that device terminals are kept at ambient temperature.
 - B. Tested with pulses, T_p ≤ 1.0mS.

Electrical Characteristics(Ta = 25°C)

Part Number	Zener Voltage			Operating Resistance		Rising Operating Resistance		Reverse Current		Marking Code
	VZ(V)@IZT			ZZT(Ohm)		ZZK(Ohm)		IR(μA)		
	Min.	Nom.	Max.	Max.	IZT(mA)	Max.	IZK(mA)	Max.	VR(V)	
CZRT5221B-G	2.28	2.4	2.52	30	20.0	1200	0.25	100	1.0	KC1
CZRT5222B-G	2.38	2.5	2.63	30	20.0	1250	0.25	100	1.0	KC2
CZRT5223B-G	2.57	2.7	2.84	30	20.0	1300	0.25	75	1.0	KC3
CZRT5225B-G	2.85	3.0	3.15	30	20.0	1600	0.25	50	1.0	KC5
CZRT5226B-G	3.14	3.3	3.47	28	20.0	1600	0.25	25	1.0	KG1
CZRT5227B-G	3.42	3.6	3.78	24	20.0	1700	0.25	15	1.0	KG2
CZRT5228B-G	3.71	3.9	4.10	23	20.0	1900	0.25	10	1.0	KG3
CZRT5229B-G	4.09	4.3	4.52	22	20.0	2000	0.25	5.0	1.0	KG4
CZRT5230B-G	4.47	4.7	4.94	19	20.0	1900	0.25	5.0	2.0	KG5
CZRT5231B-G	4.85	5.1	5.36	17	20.0	1600	0.25	5.0	2.0	KE1
CZRT5232B-G	5.32	5.6	5.88	11	20.0	1600	0.25	5.0	3.0	KE2
CZRT5234B-G	5.89	6.2	6.51	7	20.0	1000	0.25	5.0	4.0	KE4
CZRT5235B-G	6.46	6.8	7.14	5	20.0	750	0.25	3.0	5.0	KE5
CZRT5236B-G	7.13	7.5	7.88	6	20.0	500	0.25	3.0	6.0	KF1
CZRT5237B-G	7.79	8.2	8.61	8	20.0	500	0.25	3.0	6.5	KF2
CZRT5239B-G	8.65	9.1	9.56	10	20.0	600	0.25	3.0	7.0	KF4
CZRT5240B-G	9.50	10	10.50	17	20.0	600	0.25	3.0	8.0	KF5
CZRT5241B-G	10.45	11	11.55	22	20.0	600	0.25	2.0	8.4	KH1
CZRT5242B-G	11.40	12	12.60	30	20.0	600	0.25	1.0	9.1	KH2
CZRT5243B-G	12.35	13	13.65	13	9.5	600	0.25	0.5	9.9	KH3
CZRT5245B-G	14.25	15	15.75	16	8.5	600	0.25	0.1	11	KH5
CZRT5246B-G	15.20	16	16.80	17	7.8	600	0.25	0.1	12	KJ1
CZRT5248B-G	17.10	18	18.90	21	7.0	600	0.25	0.1	14	KJ3
CZRT5250B-G	19.00	20	21.00	25	6.2	600	0.25	0.1	15	KJ5
CZRT5251B-G	20.90	22	23.10	29	5.6	600	0.25	0.1	17	KK1
CZRT5252B-G	22.80	24	25.20	33	5.2	600	0.25	0.1	18	KK2
CZRT5254B-G	25.65	27	28.35	41	5.0	600	0.25	0.1	21	KK4
CZRT5255B-G	26.60	28	29.40	44	4.5	600	0.25	0.1	21	KK5
CZRT5256B-G	28.50	30	31.50	49	4.2	600	0.25	0.1	23	KM1
CZRT5257B-G	31.35	33	34.65	58	3.8	700	0.25	0.1	25	KM2
CZRT5258B-G	34.20	36	37.80	70	3.4	700	0.25	0.1	27	KM3
CZRT5259B-G	37.05	39	40.95	80	3.2	800	0.25	0.1	30	KM4
CZRT5260B-G	40.85	43	45.15	93	3.0	900	0.25	0.1	33	KM5
CZRT5261B-G	44.65	47	49.35	105	2.7	1000	0.25	0.1	36	KN1
CZRT5262B-G	48.45	51	53.55	125	2.5	1100	0.25	0.1	39	KN2
CZRT5263B-G	53.20	56	58.80	150	2.2	1300	0.25	0.1	43	KN3
CZRT5264B-G	57.00	60	63.00	170	2.1	1400	0.25	0.1	46	KN4
CZRT5265B-G	58.90	62	65.10	185	2.0	1500	0.25	0.1	47	KN5
CZRT5266B-G	64.60	68	71.40	230	1.8	1600	0.25	0.1	52	KP1
CZRT5267B-G	71.25	75	78.75	270	1.7	1400	0.25	0.1	56	KP2

Note: 5% Standard Vz Tolerance

RATING AND CHARACTERISTIC CURVES (CZRT5221B-G Thru CZRT5267B-G)

Fig.1 Typical forward voltage

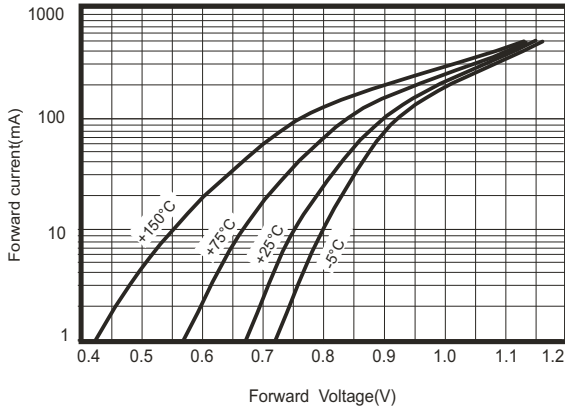

Fig.2 Typical leakage current

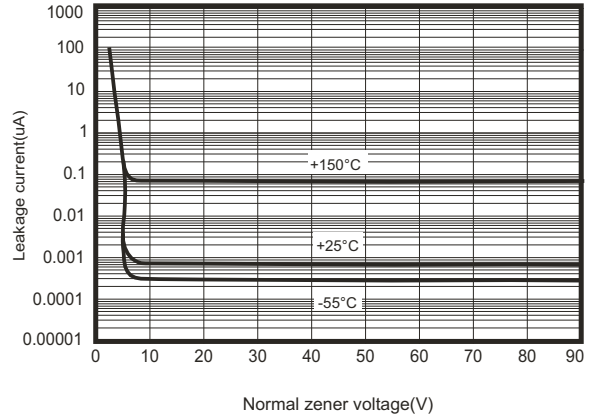

Fig.3 Temperature coefficients

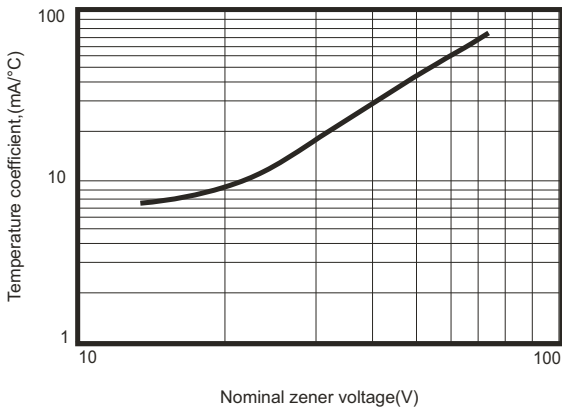
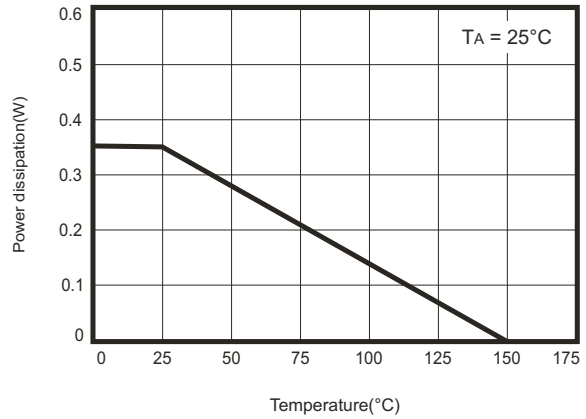
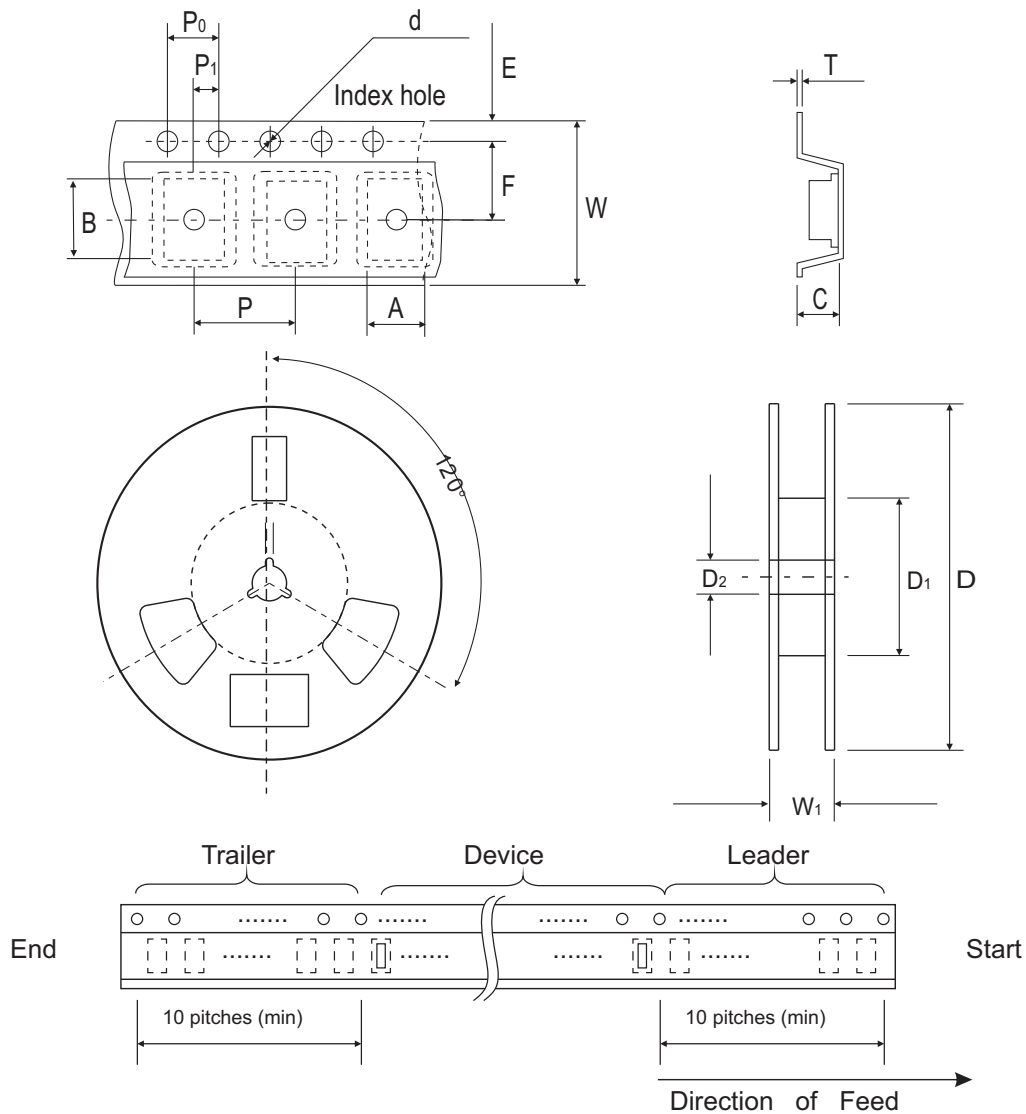

Fig.4 Steady state power derating



Reel Taping Specification



SOT-23	SYMBOL	A	B	C	d	D	D ₁	D ₂
	(mm)	3.10 ± 0.10	2.85 ± 0.10	1.40 ± 0.10	1.55 ± 0.10	178 ± 1	50.0 MIN.	13.0 ± 0.20
	(inch)	0.122 ± 0.004	0.112 ± 0.004	0.055 ± 0.004	0.061 ± 0.004	7.008 ± 0.04	1.969 MIN.	0.512 ± 0.008

SOT-23	SYMBOL	E	F	P	P ₀	P ₁	W	W ₁
	(mm)	1.75 ± 0.10	3.50 ± 0.05	4.00 ± 0.10	4.00 ± 0.10	2.00 ± 0.05	8.00 ± 0.30	14.4 MAX.
	(inch)	0.069 ± 0.004	0.138 ± 0.002	0.157 ± 0.004	0.157 ± 0.004	0.079 ± 0.002	0.315 ± 0.012	0.567 MAX.

Suggested PAD Layout

SIZE	SOT-23	
	(mm)	(inch)
A	0.80	0.031
B	1.90	0.075
C	2.02	0.080
D	2.82	0.111

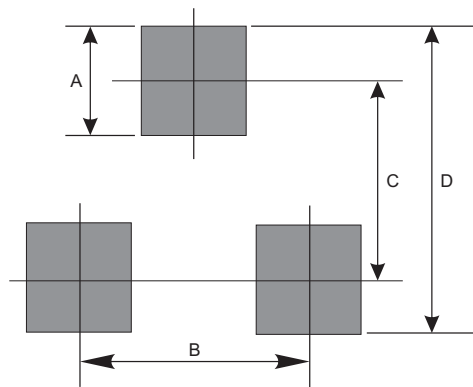

Standard Package

Case Type	Qty per Reel	Reel Size
	(Pcs)	(inch)
SOT-23	3000	7