

FEATURES

- 800 nanoseconds settling time to $\pm 0.01\%$
- Programmable SE or differential input modes
- Break-before-make switching
- Dielectrically isolated CMOS technology
- TTL/CMOS compatible channel addressing

GENERAL DESCRIPTION

The MX-1616 and MX-818 are high-speed, high-performance analog multiplexers manufactured with a dielectrically isolated CMOS process. Both devices achieve transfer accuracies of $\pm 0.01\%$ at channel sampling rates of up to 1.25MHz over $\pm 10V$ signal ranges. These multiplexers are ideal for high-speed, multichannel data acquisition systems where the multiplexer operates into a high-impedance load such as a sample-and-hold, buffer amplifier or instrumentation amplifier.

A unique feature of these circuits is the ability of the user to program their inputs for either single-ended or differential operation. The MX-1616 is user programmable either as a single-ended 16-channel or as a differential 8-channel multiplexer while the MX-818 is user programmable either as a single-ended 8-channel or as a differential 4-channel multiplexer.

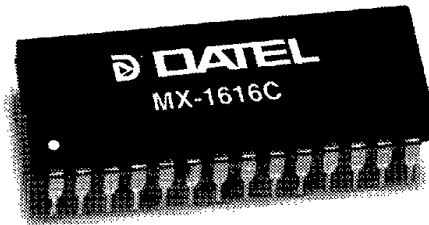

Digital inputs are user selectable for either TTL or CMOS compatibility. The proper channel is addressed by means of a 3 or 4-bit binary word. An inhibit function enables or disables the entire device, permitting expansion of the number of channels by using several devices together. Another important feature of these devices is the use of break-before-make switching to ensure that no two channels are ever momentarily shorted together.

These multiplexers are packaged in 18 and 28-pin ceramic DIP's and operate over the 0 to +70°C operating temperature range.

INPUT/OUTPUT CONNECTIONS

MX-1616

PIN	FUNCTION	PIN	FUNCTION
1	+V _S	28	A OUT
2	B OUT	27	-V _S
3	N.C.	26	8A IN
4	8B IN	25	7A IN
5	7B IN	24	6A IN
6	6B IN	23	5A IN
7	5B IN	22	4A IN
8	4B IN	21	3A IN
9	3B IN	20	2A IN
10	2B IN	19	1A IN
11	1B IN	18	INHIBIT
12	GND	17	CA0
13	LS	16	CA1
14	CA3	15	CA2

MX-818

PIN	FUNCTION	PIN	FUNCTION
1	+V _S	18	A OUT
2	B OUT	17	-V _S
3	4B IN	16	4A IN
4	3B IN	15	3A IN
5	2B IN	14	2A IN
6	1B IN	13	1A IN
7	GND	12	INHIBIT
8	LS	11	CA0
9	CA2	10	CA1

NOTES: CA = Channel address LS = Logic select
V_S = Supply voltage N.C. = No connection

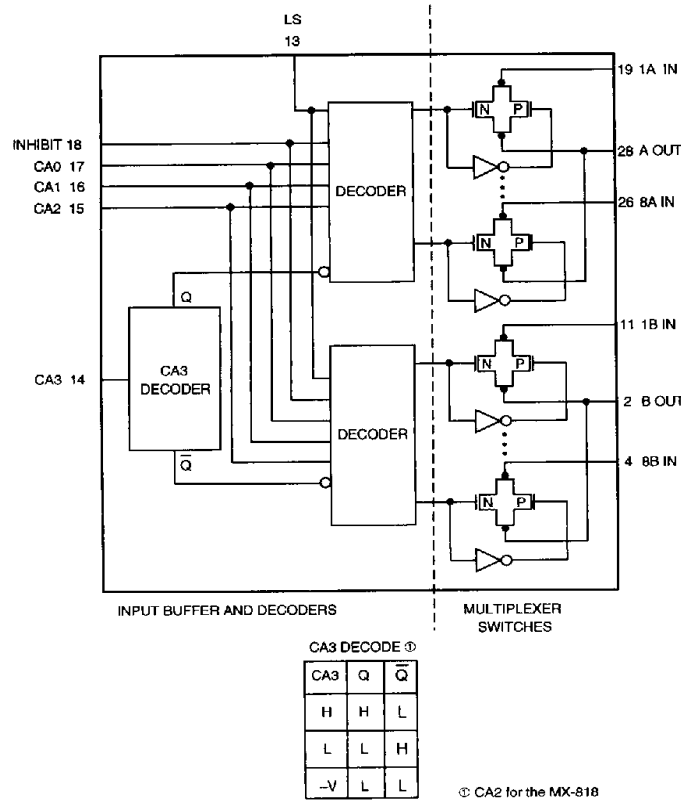

Figure 1. Functional Block Diagram (MX-1616 Pinout Shown)

2651561 0003626 16T

ABSOLUTE MAXIMUM RATINGS

PARAMETERS	MX-1616C	MX-818C
Voltage Between Supply Pins	33Vdc	33Vdc
Analog Input Voltage	$\pm 1V_S \pm 2V_I$	$\pm 1V_S \pm 2V_I$
Digital Input Voltage:		
TTL ①	$-6V < \text{Logic "1"} < +6V$	$-6V < \text{Logic "1"} < +6V$
CMOS ②	$CA3 = \pm 1V_S \pm 2V_I$ $+V_S + 2V$ $GND - 2V$	$CA2 = \pm 1V_S \pm 2V_I$ $+V_S + 2V$ $GND - 2V$
Power Dissipation	1200mW	725mW

Footnotes:

- ① For TTL compatibility, the LS (logic select) pin (MX-1616 pin 13, MX-818 pin 8) is grounded or left open.
- ② For CMOS compatibility, the LS (logic select) pin (MX-1616 pin 13, MX-818 pin 8) is tied to the system logic supply (+V_{DD}).
- ③ V_{in} = ±10V, I_{out} = -100µA
- ④ 225nsec maximum at full rated operating temperature.

FUNCTIONAL SPECIFICATIONS

(Typical at +25°C and ±15V supplies, unless otherwise noted.)

ANALOG INPUTS	MX-1616C	MX-818C
Number of Channels	16 single-ended 8 differential	8 single-ended 4 differential
Input Voltage Range	±15V	±15V
Channel ON		
Resistance (max.) ③	750Ω	750Ω
Resistance Over Temp. (max.) ③	1kΩ	1kΩ
Leakage	40pA	15pA
Channel OFF		
Input Leakage	10pA	10pA
Output Leakage	35pA	15pA
Input Capacitance (max.)	10pF	5pF
Output Capacitance (max.)	25pF	10pF
DIGITAL INPUTS ① ②		
Logic "0" Threshold (max.)		
TTL	+0.8V	+0.8V
CMOS	+0.3V _{DD}	+0.3V _{DD}
Logic "1" Threshold (min.)		
TTL	+2.4V	+2.4V
CMOS	+0.7V _{DD}	+0.7V _{DD}
Input Leakage Current (max.)		
High	1µA	1µA
Low	25µA	20µA
Channel Address Coding	4 bits	3 bits
Channel Inhibit (all channels OFF)	Logic "0"	Logic "0"
PERFORMANCE		
Transfer Error (max.)	±0.01%	±0.01%
Settling Time		
10V Step to ±0.1%	250ns	250ns
10V Step to ±0.01%	800ns	800ns
Access Time (max.)	130ns ④	130ns ④
Enable Delay ON (max.)	175ns	175ns
Enable Delay OFF (max.)	175ns	175ns
Break-Before-Make Delay	20ns	20ns
POWER REQUIREMENTS		
Rated Power Supply Voltage	±15V	±15V
Quiescent Current (max.)	±30mA	±18mA
Power Dissipation (max.)	900mW	540mW
PHYSICAL/ENVIRONMENTAL		
Operating Temperature Range	0 to +70°C	0 to +70°C
Storage Temperature Range	-65 to +155°C	-65 to +155°C
Package	28-pin DIP	18-pin DIP

TECHNICAL NOTES

1. The transfer accuracy of the MX-1616 and MX-818 depends upon both the source and the load resistances. With zero source resistance and assuming 1kΩ maximum channel ON resistance, the load impedance must be at least 10MΩ to achieve 0.01% accuracy. This can be done by using a good high-gain, high-CMR operational amplifier as a buffer. Source resistance should be kept as low as possible so that accuracy and settling time are not degraded. Less than 500Ω is recommended.
2. For differential operation, two buffer amplifiers or a good instrumentation amplifier should be used. To maintain high CMR, source impedance unbalance should be kept to a minimum, the highest possible load impedance should be used and an amplifier with high CMR should be chosen.
3. These devices have the added feature of being programmable for single-ended or differential operation. The MX-1616 is user programmed for single-ended 16-channel operation by connecting A OUT (pin 28) to B OUT (pin 2) and using CA3 (pin 14) as a digital address input. To program the MX-1616 for differential 8-channel operation, CA3 (pin 14) is simply connected to -V_S (pin 27). The MX-818 may be programmed as a single-ended 8-channel multiplexer by connecting A OUT (pin 18) to B OUT (pin 2) and using CA2 (pin 9) as a digital input address, or as a differential 4-channel multiplexer by connecting CA2 (pin 9) to -V_S (pin 17). Refer to the truth tables for channel addressing.
4. Both devices are selectable for either TTL or CMOS compatibility. For TTL compatibility, the LS (logic select) pin (MX-1616 pin 13, MX-818 pin 8) is left open or grounded. For CMOS compatibility, the LS pin should be connected to the system logic supply (+V_{DD}).
5. Channel expansion is accomplished by the use of the inhibit input of the multiplexers. To expand the number of channels, use multiple multiplexers with the inhibit inputs connected to a decoder.

2651561 0003627 0T6

CHANNEL ADDRESSING

MX-1616 USED AS 16-CHANNEL MULTIPLEXER

USE CA3 AS A DIGITAL ADDRESS INPUT				Inhibit	ON CHANNEL TO	
3	2	1	0		Output A	Output B
X	X	X	X	0	None	None
0	0	0	0	1	1A	—
0	0	0	1	1	2A	—
0	0	1	0	1	3A	—
0	0	1	1	1	4A	—
0	1	0	0	1	5A	—
0	1	0	1	1	6A	—
0	1	1	0	1	7A	—
0	1	1	1	1	8A	—
1	0	0	0	1	—	1B
1	0	0	1	1	—	2B
1	0	1	0	1	—	3B
1	0	1	1	1	—	4B
1	1	0	0	1	—	5B
1	1	0	1	1	—	6B
1	1	1	0	1	—	7B
1	1	1	1	1	—	8B

MX-818 USED AS DUAL 4-CHANNEL MULTIPLEXER

CONNECT CA2 TO -V SUPPLY			ON CHANNEL TO	
1	0	Inhibit	Output A	Output B
X	X	0	None	None
0	0	1	1A	1B
0	1	1	2A	2B
1	0	1	3A	3B
1	1	1	4A	4B

MX-1616 USED AS DUAL 8-CHANNEL MULTIPLEXER

CONNECT CA3 TO -V SUPPLY				ON CHANNEL TO	
2	1	0	Inhibit	Output A	Output B
X	X	X	0	None	None
0	0	0	1	1A	1B
0	0	1	1	2A	2B
0	1	0	1	3A	3B
0	1	1	1	4A	4B
1	0	0	1	5A	5B
1	0	1	1	6A	6B
1	1	0	1	7A	7B
1	1	1	1	8A	8B

MX-818 USED AS 8-CHANNEL MULTIPLEXER

USE CA2 AS A DIGITAL ADDRESS INPUT				ON CHANNEL TO	
2	1	0	Inhibit	Output A	Output B
X	X	X	0	None	None
0	0	0	1	1A	—
0	0	1	1	2A	—
0	1	0	1	3A	—
0	1	1	1	4A	—
1	0	0	1	—	1B
1	0	1	1	—	2B
1	1	0	1	—	3B
1	1	1	1	—	4B

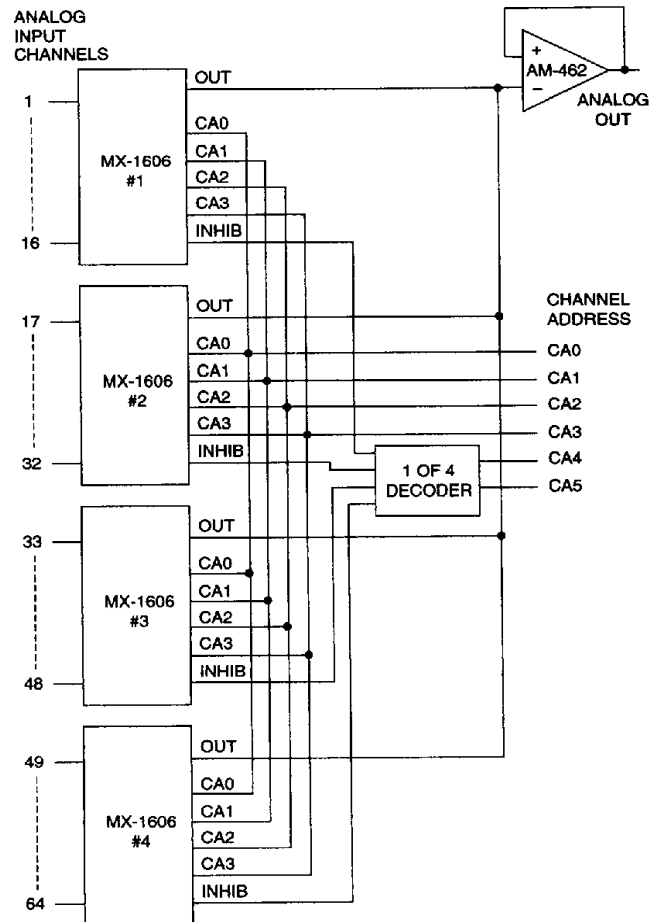
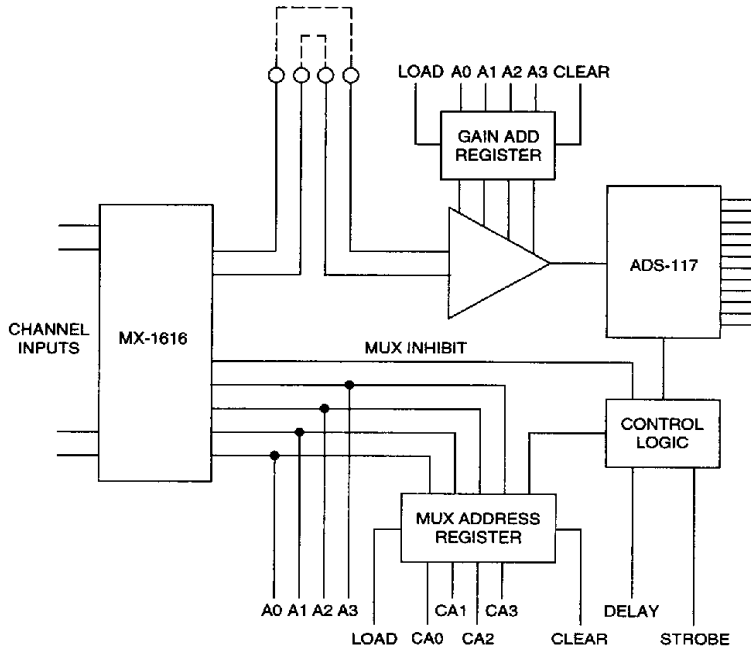

Figure 2. Expansion to 64 Channels

2651561 0003628 T32

APPLICATIONS



NOTE: This application diagram shows a high-speed data acquisition system with 8 differential inputs and 12-bit resolution that utilizes the MX-1616. If the control logic is timed so that the sampling A/D section is converting one analog value while the mux-amplifier section is allowed to settle to the next input value, throughput rates approaching 1MHz can be achieved. The MX-1616 is used with DATEL's ADS-117, a 12-bit sampling A/D with a 2MHz conversion rate.

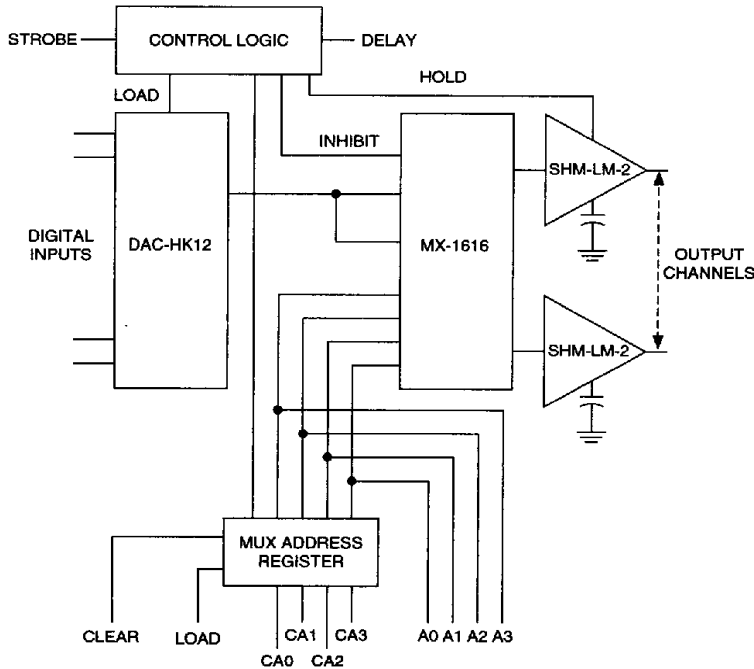

NOTE: The switches in a CMOS multiplexer will conduct equally well in either direction, making it feasible to use them as single input-selected multiple output switches. The circuit shown is capable of sample rates of 78kHz for inputs of $\pm 10V$. The MX-1616 is used with DATEL's DAC-HK12, a 12-bit hybrid D/A with input registers and the SHM-LM-2, a low-cost monolithic sample-and-hold.

2651561 0003629 979

MECHANICAL DIMENSIONS INCHES (mm)

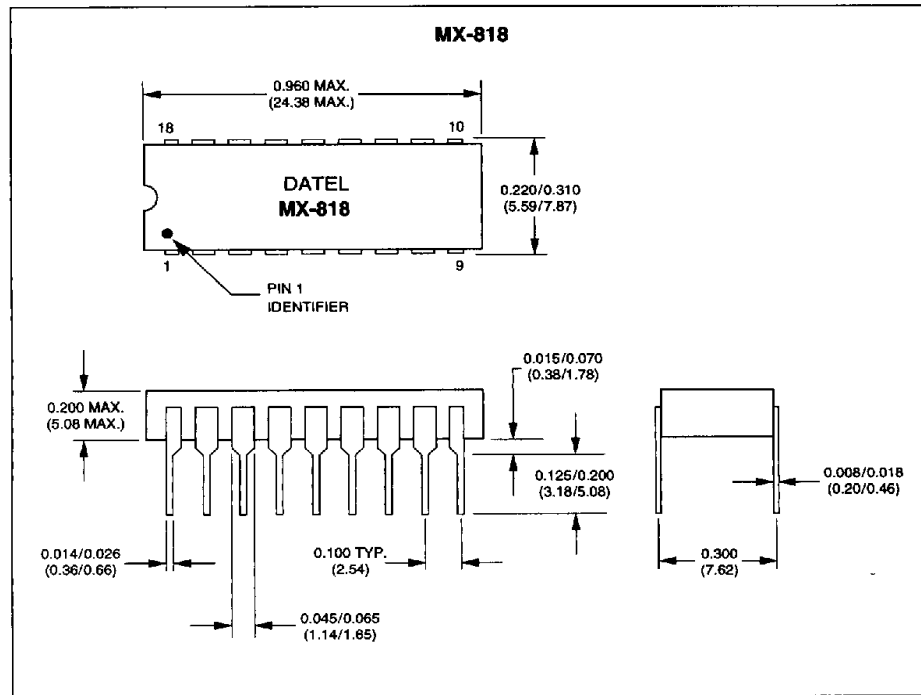
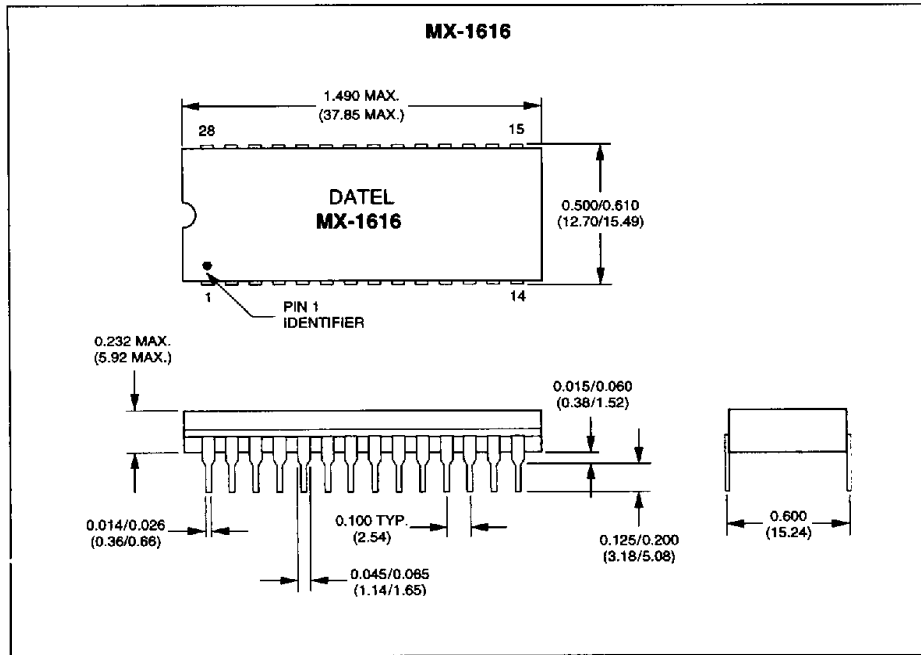

ORDERING INFORMATION

MODEL	CHANNELS	OPERATING TEMP. RANGE
MX-818C	8 S.E. or 4 Diff.	0 to +70°C
MX-1616C	16 S.E. or 8 Diff.	0 to +70°C

5

2651561 0003630 690