

**FEATURES**

- 50ns settling time to  $\pm 0.01\%$
- 70ns settling time to  $\pm 0.003\%$
- 100ns settling time to  $\pm 0.001\%$
- 4 Channels, single-ended inputs
- 100mW power dissipation
- Small, 14-pin DIP package



**GENERAL DESCRIPTION**

The MX-850 is a precision, high-speed multiplexer characterized for 10, 12, 14 and 16-bit applications. The performance benchmarks are its 50 nanosecond maximum settling time to  $\pm 0.01\%$  accuracy and its unprecedented  $\pm 0.001\%$  accuracy specification.

Packaged in a miniature, 14-pin, ceramic DIP, the MX-850 operates from  $\pm 15V$  and  $+5V$  supplies and consumes a maximum 270mW. Models are available for either 0 to  $+70^\circ C$  or  $-55$  to  $+125^\circ C$  operation.

**INPUT/OUTPUT CONNECTIONS**

PIN	FUNCTION
1	$\overline{EN}$ ENABLE
2	A0
3	A1
4	CH1 INPUT
5	CH2 INPUT
6	CH3 INPUT
7	CH4 INPUT
8	OUTPUT
9	GROUND
10	+15V SUPPLY
11	GROUND
12	+5V SUPPLY
13	GROUND
14	-15V SUPPLY

Table 1. Channel Addressing

ON CHANNEL	MUX ADDRESS		
	$\overline{EN}$	A <sub>1</sub>	A <sub>0</sub>
Disable	1	X	X
1	0	0	0
2	0	0	1
3	0	1	0
4	0	1	1

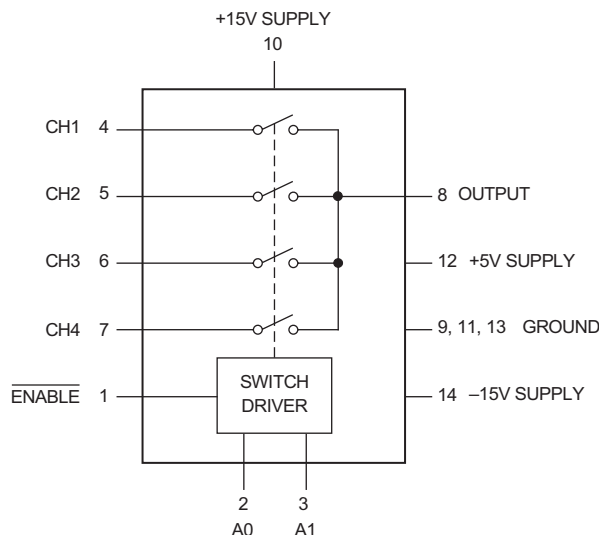

Figure 1. Functional Block Diagram

**ABSOLUTE MAXIMUM RATINGS**

PARAMETER	LIMITS	UNITS
+15V Supply, Pin 10	-0.5 to +16.5	Volts
-15V Supply, Pin 14	+0.5 to -16.5	Volts
+5V Supply, Pin 12	-0.5 to +7	Volts
Digital Inputs, Pins 1, 2, 3	-0.5 to +6	Volts
Analog Inputs, Pins 4, 5, 6, 7	-10.5 to +10.5	Volts
Analog Input Current	±20	mA
Lead temperature (10 seconds)	300	°C
Switching Frequency/Duty Cycle	10/50	MHz/%

**FUNCTIONAL SPECIFICATIONS**

(Apply over the operating temperature range and over the operating power supply range unless otherwise specified.)

ANALOG INPUTS	MIN.	TYP.	MAX.	UNITS
<b>Analog Signal Range</b>	±10	—	—	Volts
<b>On Resistance, +25°C</b>	—	18	90	Ohms
0 to +70°C	—	—	120	Ohms
-55 to +125°C	—	—	140	Ohms
<b>R<sub>ON</sub> versus V<sub>IN</sub></b>	See Figure 2			
<b>Input Leakage Current (Off)</b>	—	±0.02	±0.2	nA
+25°C	—	—	±10	nA
0 to +70°C	—	—	±25	nA
-55 to +125°C	—	—	—	—
<b>Output Leakage Current (Off)</b>	—	±0.02	±0.2	nA
+25°C	—	—	±20	nA
0 to +70°C	—	—	±40	nA
-55 to +125°C	—	—	—	—
<b>On Channel Leakage Current</b>	—	±0.4	±1	nA
+25°C	—	—	±25	nA
0 to +70°C	—	—	±35	nA
-55 to +125°C	—	—	—	—
<b>Channel Input Capacitance</b>	—	4	6	pF
Off	—	10	12	pF
On	—	8	10	pF
<b>Channel Output Capacitance</b>	—	8	10	pF
On	—	—	±0.001	%FSR
<b>Nonlinearity</b>	—	—	—	MHz
<b>Large signal bandwidth (-3dB)</b>	80	100	—	—
<b>DIGITAL INPUTS</b>				
<b>Logic levels</b>	+2.0	—	—	Volts
Logic "1"	—	—	+0.8	Volts
Logic "0"	—	—	+10	µA
<b>Logic Loading "1"</b>	—	—	-10	µA
<b>Logic Loading "0"</b>	—	—	—	—
<b>SWITCHING CHARACTERISTICS</b>				
<b>Access Time</b>	—	—	20	ns
<b>Break-Before-Make Delay Time</b>	—	—	10	ns
<b>Enable Delay (On, Off)</b>	—	3	10	ns
<b>Settling Time, 10M Load</b>	—	—	—	—
10V step to ±0.1%	—	25	30	ns
10V step to ±0.01%	—	40	50	ns
10V step to ±0.003%	—	60	70	ns
10V step to ±0.001%	—	80	100	ns
<b>Settling Time, 5k Load</b>	—	—	—	—
10V step to ±0.1%	—	25	30	ns
10V step to ±0.01%	—	40	50	ns
10V step to ±0.003%	—	60	70	ns
10V step to ±0.001%	—	80	100	ns
<b>Settling Time, 10M Load</b>	—	—	—	—
20V step to ±0.1%	—	30	35	ns
20V step to ±0.01%	—	50	60	ns
20V step to ±0.003%	—	75	85	ns
20V step to ±0.001%	—	100	120	ns

SWITCHING CHAR. (cont.)	MIN.	TYP.	MAX.	UNITS
<b>Settling Time, 5k Load</b>	—	30	35	ns
20V step to ±0.1%	—	50	60	ns
20V step to ±0.01%	—	75	85	ns
20V step to ±0.003%	—	100	120	ns
20V step to ±0.001%	—	—	—	—
<b>Crosstalk ①</b>	—	-105	-100	dB
10kHz (20Vp-p)	—	-94	-92	dB
1MHz (20Vp-p)	—	-76	-71	dB
10MHz (5Vp-p)	—	-64	-62	dB
20MHz (3Vp-p)	—	—	—	—

**POWER REQUIREMENTS**

<b>Power Supply Range</b>	+14.5	+15	+15.5	Volts
+15V Supply	-14.5	-15	-15.5	Volts
-15V Supply	+4.75	+5	+5.25	Volts
+5V Supply	—	+3	+4	mA
<b>Power Supply Current, Quiescent</b>	—	-10	-12	mA
+15V Supply	—	+3	+3.5	mA
-15V Supply	80	90	—	dB
+5V Supply	—	—	—	—
<b>Power Supply Rejection Ratio</b>	—	207	270	mW
<b>Power Supply Dissipation, Quiescent</b>	—	—	270	mW
+25°C	—	—	280	mW
0 to +70°C	—	—	—	—
-55 to +125°C	See Figure 4			
<b>Pd versus Frequency</b>	See Figure 4			

**PHYSICAL/ENVIRONMENTAL**

<b>Operating Temp. Range, Case</b>	0	—	+70	°C
MX-850MC	-55	—	+125	°C
MX-850MM	-65	—	+150	°C
<b>Storage Temperature Range</b>	14-pin, metal-sealed, ceramic DIP			
<b>Package Type</b>	0.1 ounces (2.8 grams)			
<b>Weight</b>				

① See Figures 3a and 3b.

**TECHNICAL NOTES**

1. Proper operation of the MX-850 multiplexer is dependent upon good board layout and connection practices. Bypass supplies as shown in the connection diagrams. Mount bypass capacitors directly to the supply pins whenever possible.
2. All grounds pins (9, 11, 13) should be tied together and connected to ground as close to the multiplexer as possible.
3. When power is off, current limit input signals on pins 4, 5, 6, and 7 to 20mA. Failure to current limit can cause permanent damage to the device since, when powering up or down it is possible that two switches might be on at the same time. Excessive current (greater than 20mA) will flow from the more positive input to the more negative input, permanently damaging the device. Applications in which the power supply for the multiplexer also powers the signal sources may not require limiting resistors. See Figure 4.

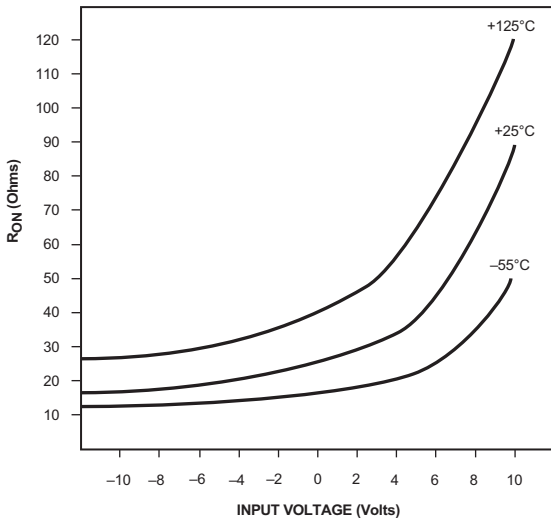

Figure 2. Channel On Resistance Versus Input Voltage

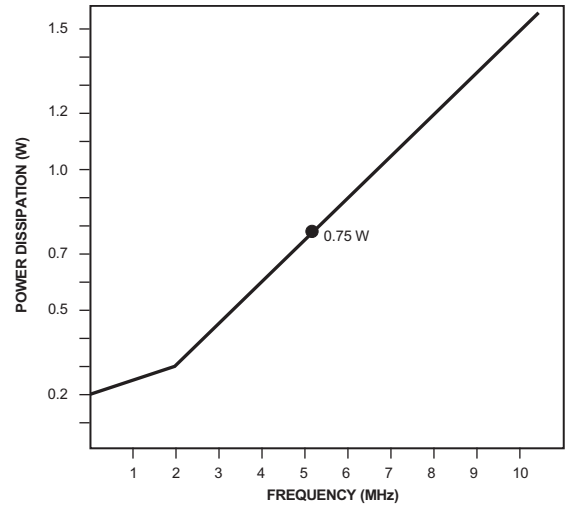

Figure 4. Power Dissipation Versus Switching Frequency

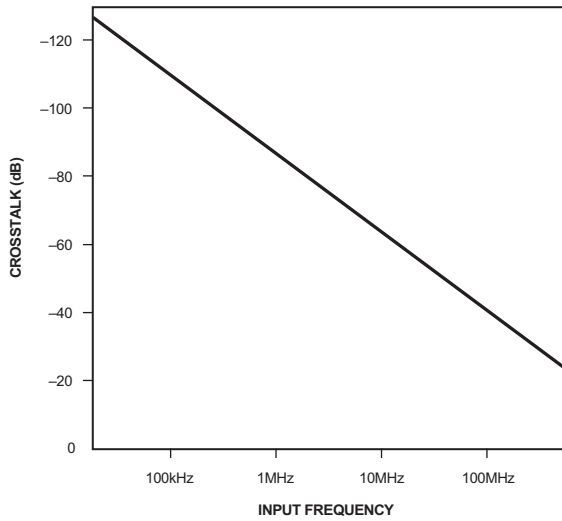

Figure 3a. Small Signal Crosstalk Versus Input Frequency

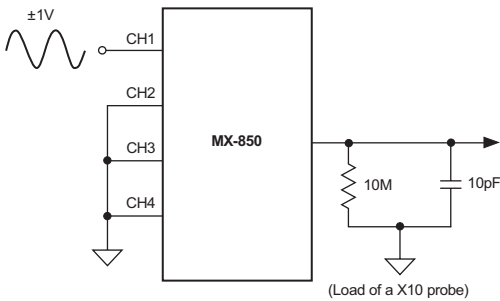

Figure 3b. Crosstalk Test Circuit

**CURRENT LIMITING RESISTORS**

As noted in Technical Note 3, some current limiting technique must be employed to protect the device. The following lists the suggested resistor values for the current limiting resistors shown in Figure 5.

Input Range	Limiting Resistors
±10V	R = 500Ω
±5V	R = 250Ω
≤±1V	No current limiting needed

Other current limiting circuits can be used, such as a current limited op amp drive, depending upon the application.

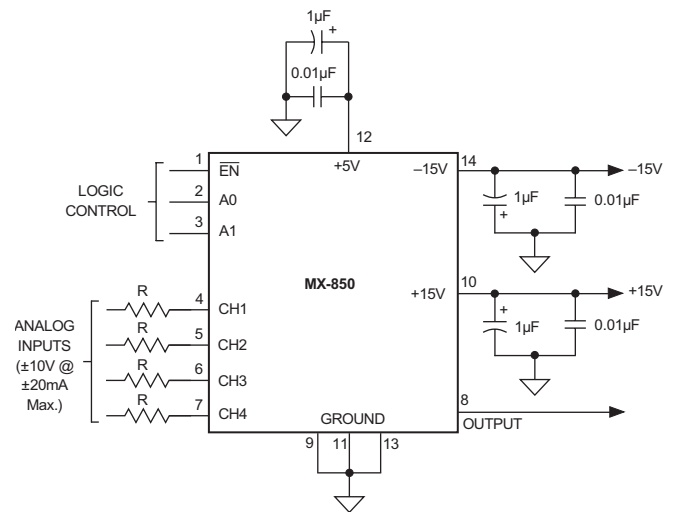
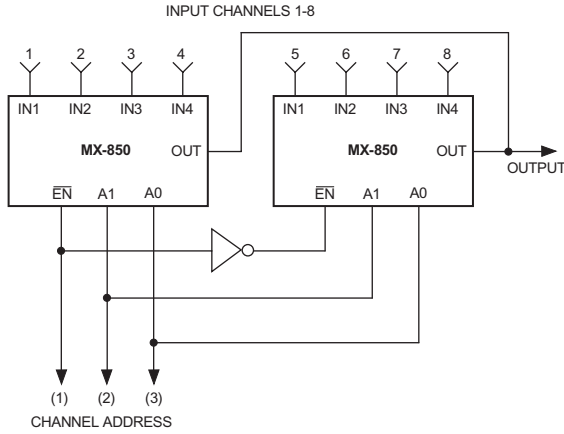

Figure 5. Typical Connections

**Table 2. 8 Channel Addressing**

ON CHANNEL	MUX ADDRESS		
	1	2	3
1	0	0	0
2	0	0	1
3	0	1	0
4	0	1	1
5	1	0	0
6	1	0	1
7	1	1	0
8	1	1	1

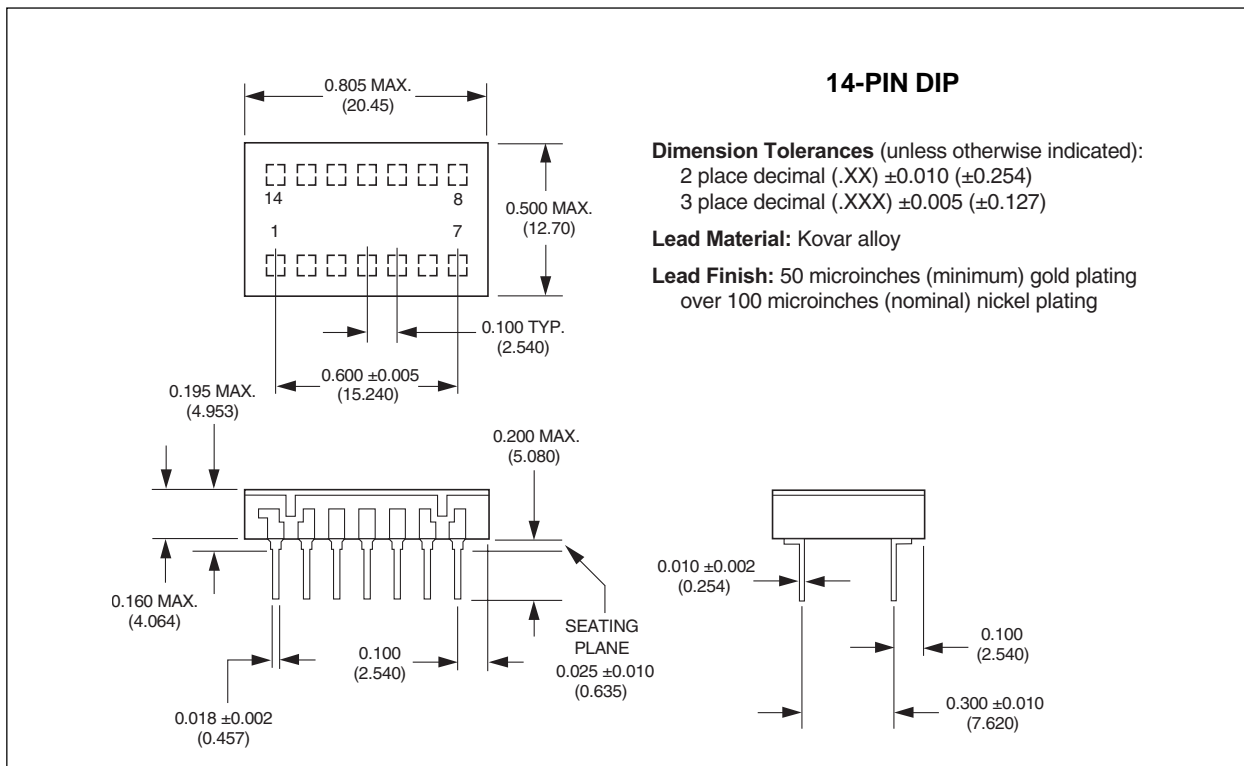

**Figure 6. Cascading Multiple MX-850's**

**CHANNEL EXPANSION**

The MX-850's ENABLE input provides a means of channel expansion. As shown in Figure 6 and in Table 2, multiple multiplexers may be used by using the ENABLE input as an address line.

**MECHANICAL DIMENSIONS  
INCHES (mm)**



**ORDERING INFORMATION**

MODEL	OPERATING TEMP. RANGE
<b>MX-850MC</b>	0 to +70°C
<b>MX-850MM</b>	-55 to +125°C

For availability of a high-reliability (QL) version, contact DATEL.