

# Commercial Styles Semi-Precision Power Wirewound Resistors

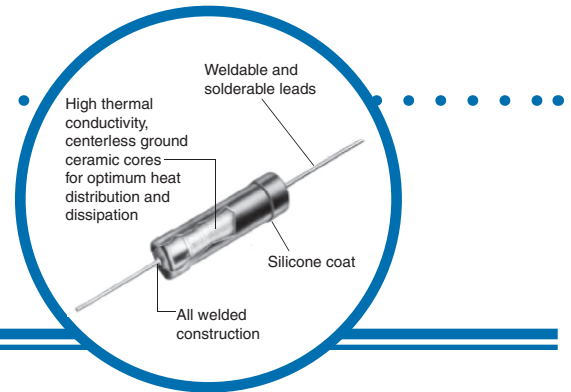

## T Wirewound Series

- 0.1Ω to 300KΩ
- 0.75 to 14 watts
- ±0.1% to ±10% tolerance
- Non-inductive windings available
- Meets or exceeds all applicable MIL-R-26 ratings



## Electrical Data

IRC Style	Similar To MIL-R-26 Style	Wattage Rating		Resistance Range (Ω)		Maximum Working Voltage
		U	V	Min Ω	Max KΩ	
T-1/2	---	0.75	---	0.1	4	54.8
T-1/2-A81	RW81	1.0	---	0.1	4.5	67.1
T-1A-70	RW70	1.0	---	0.1	12	109.5
T-1-80	RW80	2.0	---	0.1	12	154.9
T-2A*	---	3.0	3.75	0.1	25	306.2
T-2A-69	RW69	---	3.0	0.1	20	244.9
T-2B-79	RW79	3.0	---	0.1	40	346.4
T-3*	---	4.0	5.5	0.1	38	457.2
T-5*	---	5.0	6.5	0.1	45	540.8
T-5-74	RW74	5.0	---	0.1	94	685.5
T-6	---	6.0	7.5	0.1	65	698.2
T-6-67	RW67	---	6.5	0.1	92	773.3
T-7*	---	7.0	9.0	0.1	115	1017.3
T-7A-55	RW55	---	7.0	0.1	200	1183.2
T-10A-56	RW56	---	14.0	0.1	300	2049.4
T-10*	---	10.0	13.0	0.1	300	1974.8
T-10-78	RW78	10.0	---	0.1	300	1732
T-10-68	RW68	---	11.0	0.1	300	1816.6

\* Available as radial lead = type TR. To designate non-inductive winding, add prefix "N" to style.

### General Note

IRC reserves the right to make changes in product specification without notice or liability. All information is subject to IRC's own data and is considered accurate at time of going to print.

Wire and Film Technologies Division • 4222 South Staples Street • Corpus Christi Texas 78411 USA  
Telephone: 361 992 7900 • Facsimile: 361 992 3377 • Website: www.ircitt.com



A subsidiary of  
TT electronics plc

T Wirewound Series Issue December 2008 Sheet 1 of 4

# Commercial Styles Semi-Precision Power Wirewound Resistors



## General Specifications

<b>Temperature Range</b>	Characteristic U = -55°C to +275°C Characteristic V = -55°C to +350°C
<b>Standard Temperature Coefficient</b>	±20 ppm/°C 10Ω up ±50 ppm/°C 1.0Ω to 9.9Ω ±400 ppm/°C 0.50Ω to 0.999Ω ±650 ppm/°C 0.1Ω to 0.490Ω
<b>Special Temperature Coefficient</b>	Available from -30 ppm/°C to +6000 ppm/°C Temperature range for special TC's -50°C to +150°C
<b>Insulation Resistance</b>	1000 megohms minimum dry at 100 volts DC
<b>Derating</b>	Wattage rating based on operation at 25°C Derate to zero at 275°C & 350°C for "U" and "V" style rating

### Lead Material:

Tinned copperweld is standard.

Also available: Weldable Grade A nickel (bare)

### Special Features:

- Radial lead available
- Resistance network packages designed to individual customer requirements
- Temperature coefficient matching and tracking to ±5 ppm
- High thermal conductivity core (Beryllium Oxide) available. See B Series.
- Ratio tolerance matched sets available

# Commercial Styles Semi-Precision Power Wirewound Resistors

## Physical Data

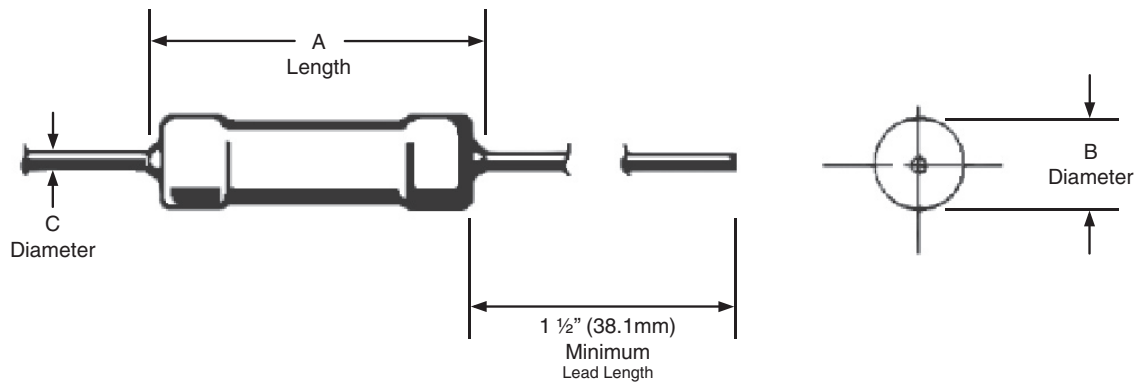

Dimensions (Inches and (mm))

IRC / Shallcross Style	A		B		C	
	Inches	mm	Inches	mm	Inches (±0.002)	mm (±0.05)
T-1/2	0.330 (±0.062)	8.4 (±1.6)	0.078 (±0.031)	2.0 (±0.8)	0.020	0.5
T-1/2-A81	0.250 (±0.032)	6.4 (±0.8)	0.085 (±0.020)	2.2 (±0.5)	0.020	0.5
T-1A-70	0.406 (±0.032)	10.3 (±0.8)	0.094 (±0.032)	2.4 (±0.8)	0.020	0.5
T-1-80	0.406 (±0.032)	10.3 (±0.8)	0.094 (±0.032)	2.4 (±0.8)	0.020	0.5
T-2A	0.500 (±0.062)	12.7 (±1.6)	0.187 (±0.031)	4.8 (±0.8)	0.032	0.8
T-2A-69	0.500 (±0.063)	12.7 (±1.6)	0.188 (±0.063)	4.8 (±1.6)	0.032	0.8
T-2B-79	0.560 (±0.062)	14.2 (±1.6)	0.187 (±0.031)	4.8 (±0.8)	0.032	0.8
T-3	0.625 (±0.062)	15.8 (±1.6)	0.250 (±0.062)	6.3 (±1.6)	0.040	1.0
T-5	0.875 (±0.062)	22.2 (±1.6)	0.312 (±0.062)	7.9 (±1.6)	0.040	1.0
T-5-74	0.875 (±0.062)	22.2 (±1.6)	0.312 (±0.062)	7.9 (±1.6)	0.040	1.0
T-6	1.000 (±0.062)	25.4 (±1.6)	0.312 (±0.062)	8.0 (±1.6)	0.040	1.0
T-6-67	1.000 (±0.094)	25.4 (±2.4)	0.313 (±0.063)	8.0 (±1.6)	0.032	0.8
T-7	1.185 (±0.062)	30.0 (±1.6)	0.312 (±0.062)	8.0 (±1.6)	0.040	1.0
T-7A-55	1.375 (±0.094)	35.0 (±2.4)	0.469 (±0.094)	12 (±2.4)	0.032	0.8
T-10A-56	2.000 (±0.094)	50.8 (±2.4)	0.469 (±0.094)	12 (±2.4)	0.032	0.8
T-10	1.812 (±0.062)	46.0 (±1.6)	0.375 (±0.062)	9.5 (±1.6)	0.040	1.0
T-10-78	1.780 (±0.062)	45.2 (±1.6)	0.375 (±0.062)	9.5 (±1.6)	0.040	1.0
T-10-68	1.875 (±0.063)	47.6 (±1.6)	0.344 (±0.094)	8.7 (±2.4)	0.032	0.8

# Commercial Styles Semi-Precision Power Wirewound Resistors



## Ordering Data

