

5-MODE PRESET EQUALIZER IC WITH BASS BOOSTER & 3D EFFECTS

DESCRIPTION

The SC5389 is a 2-channel digital preset equalizer utilizing CMOS technology. It provides 5 different sound selections, namely: Flat/Normal, Rock, Pops, Classic and Jazz. Bass Booster and 3D Effects may be added to any of 5 sound selections, thereby creating more audio versatility. SC5389 provides two types of key selection mode, namely: the Direct and the Cyclic. Pin assignment and application circuit are optimized for cost saving advantages and easy PCB layout.

FEATURES

- * CMOS Technology
- * Low Total Harmonic Distortion and High S/N Ratio:
THD+N<0.01%, S/N>95dB
- * LED Display Output Mode
- * 5 Sound Selections Provided: Flat/Normal, Classic, Rock, Pops, and Jazz
- * Bass Booster Function & 3D Effect Provided
- * 2-Channel Output
- * Wide Operating Voltage Range: 5 – 9 V
- * Direct or Cyclic Key Selection is Provided

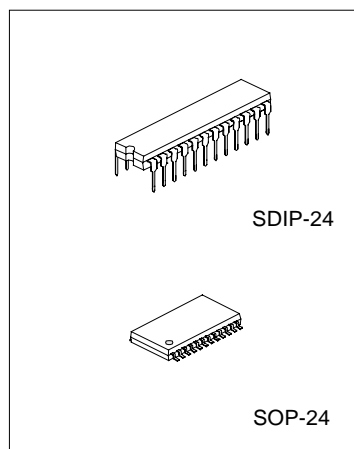

ORDERING INFORMATION

SC5389	SDIP-24 Packaged
SC5389S	SOP-24 Packaged

APPLICATIONS

- * Car Audio
- * Mini compo
- * Multimedia Audio Components

PIN CONFIGURATION

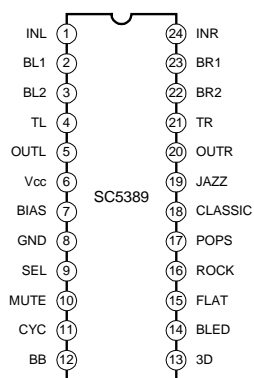

BLOCK DIAGRAM

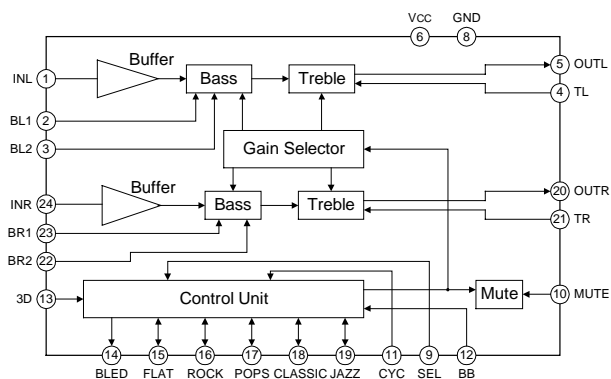

ABSOLUTE MAXIMUM RATINGS

Parameter	Symbol	Rating	Unit
Supply Voltage	V _{cc}	10	V
Operating Temperature	T _{opr}	-20 ~ 75	°C
Storage Temperature	T _{stg}	-40 ~ 125	°C
Input Voltage	V _i	-0.3 ~ V _{cc} +0.3	V

ELECTRICAL CHARACTERISTICS (Unless otherwise specified, V_{cc}=9V, V_i=1V_{rms}, f=1kHz)

Parameter	Symbol	Test conditions	Min	Typ	Max	Unit
Supply Voltage	V _{cc}	--	5	9	9.5	V
Supply Current	I _{cc}	V _{cc} = 9V, V _i = 0V, Flat mode	--	25	--	mA
Maximum Output Voltage	V _{OM}	V _{cc} = 9V	2.5	--	--	V _{rm}
Output Noise	V _{NO}	V _{cc} = 9V, V _i = 0V BW = 20~20kHz A - Weighting	--	--	-90	dB
Total Harmonic Distortion	THD	V _{cc} = 9V, V _i = 0.2V _{rms} BW = 20~20kHz	--	--	0.01	%
Input Impedance	R _{IN}	V _{cc} = 9V	--	100	--	kΩ
Output Impedance	R _{OUT}	V _{cc} = 9V	--	40	--	Ω
High Level Input Voltage	V _{IH}	V _{cc} = 9V	--	--	0.7V _{cc}	V
Low Level Input Voltage	V _{IL}	V _{cc} = 9V	0.3V _{cc}	--	--	V
Maximum Input Voltage	V _{IMAX}	V _{cc} = 9V, Flat mode, BB & 3D Off	--	--	2.0	V _{rms}

PIN DESCRIPTION

Pin No	Symbol	I/O	Function
1	INL	I	Left channel input
2	BL1	--	Left bass control pin 1. A capacitor may be connected between this pin and BL2.
3	BL2	--	Left bass control pin 2. A capacitor may be connected between this pin and BL1.
4	TL	--	Left treble control pin. A capacitor may be connected between this pin and OUTL.
5	OUTL	O	Left channel output pin
6	Vcc	--	Positive supply voltage
7	BIAS	--	A capacitor may be connected between this pin and GND.
8	GND	--	Ground
9	SEL	I	Select control pin
10	MUTE	--	Mute pin. The mute pin can eliminate the noise when mode changing occurs. A capacitor may be connected between this pin and GND.
11	CYC	I	Cyclic select pin
12	BB	I	Bass booster control input pin
13	3D	I/O	3D effect control input pin / output LED pin
14	BLED	O	Bass booster display pin
15	FLAT	I/O	Flat mode display & control input pin
16	ROCK	I/O	Rock mode display & control input pin
17	POPS	I/O	Pops mode display & control input pin
18	CLASSIC	I/O	Classic mode display & control input pin
19	JAZZ	I/O	Jazz mode display & control input pin
20	OUTR	O	Right channel output pin
21	TR	--	Right treble control pin A capacitor is connected between this pin and OUTR.
22	BR2	--	Right bass control pin 2 A capacitor is connected between this pin and BR1
23	BR1	--	Right bass control pin1 A capacitor is connected between this pin and BR2
24	INR	I	Right channel input pin

FUNCTIONAL DESCRIPTION

SC5389 is a 5-Mode Preset Equalizer IC with a Bass Booster and 3D Effects. It has 2 types of key selection mode, namely: Direct and Cyclic. The Direct or Cyclic Key Selection Mode are determined by the SEL pin. Please refer to the table below:

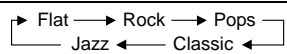
Key Selection Mode	SEL Pin	Description
Direct	Low	Press FLAT key to activate Flat Mode
		Press ROCK Key to activate Rock Mode
		Press POPS Key to activate Pops Mode
		Press CLASSIC Key to activate Classic Mode
		Press JAZZ Key to activate Jazz Mode
Cyclic*	Floating / High	

Note: The Bass Booster Function and the 3D Effect can be controlled in the same manner under the Direct or the

Cyclic Key Selection Mode. To turn the Bass Booster On or Off, press the BB Key. To turn the 3D Effect

On or Off, press the 3D key.

* = Under the Cyclic Selection Mode, press the CYC key, to go to next sound selection.

Cyclic Key Selection Mode

As seen in the table above, the Cyclic Key Selection Mode is active when the SEL Pin is Floating or "High". Under this mode, any of the sound selections (Flat, Rock, Pops, Classic, Jazz) may be selected by pressing the CYC Key. The default value is the Flat Mode. This means that when power is turned ON, the Flat mode is active. Pressing the Cyclic Key lets you go from one sound selection to the other in the following order: Flat – Rock – Pops – Classic – Jazz. Please refer to the diagram below.

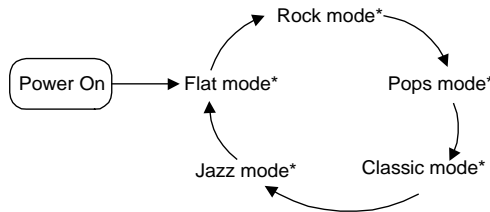

Note: * Press the CYC Key to activate the next mode
 Press the BB Key to activate the Bass Booster Function
 Press the 3D Key to activate the 3D Effect

The BB Key controls the Bass Booster. When the power is turned ON, the Bass Booster is OFF. Likewise, the 3D Key controls the 3D Effect. When the power is turned ON, the 3D Effect is OFF.

Direct Key Selection Mode

The Direct Key Selection Mode is active when the SEL Pin is set to "LOW". As the name implies, you can directly select the sound selection you like (Flat, Classic, Rock, Jazz, or Pops) simply by pressing the respective keys. This means, that to select the Jazz mode, press the JAZZ Key, Classic Mode, press the CLASSIC Key and so forth. Take note that when the power is turned ON, the Flat Mode is active. The Bass Booster Function and 3D Effect are independent of the key / sound mode selected and may be turned On or Off at any time.

FREQUENCY RESPONSE

The following diagrams illustrate the various frequency response under the various sound selection (Flat, Rock, Pops, Classic, Jazz and Bass Booster, 3D).

FLAT Mode

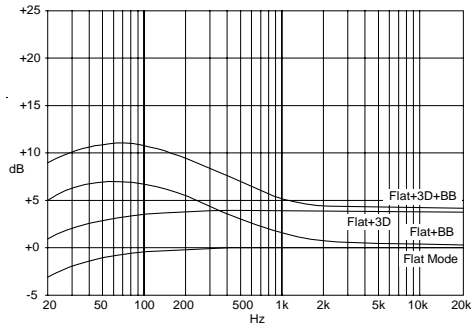

Rock Mode

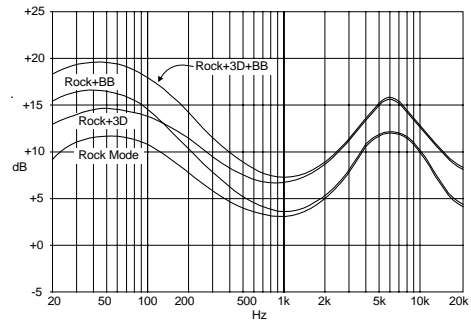

Pops Mode

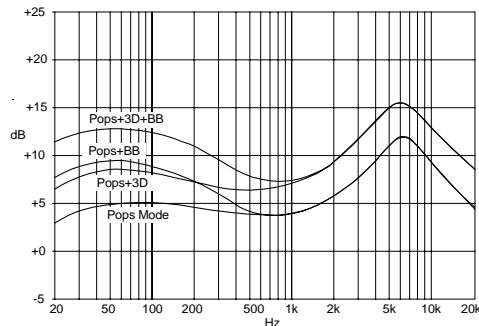

Classic Mode

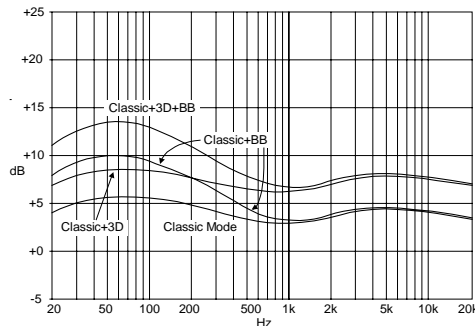

— HANGZHOU SILAN MICROELECTRONICS JOINT-STOCK CO.,LTD —

Rev: 1.0 2000.12.31

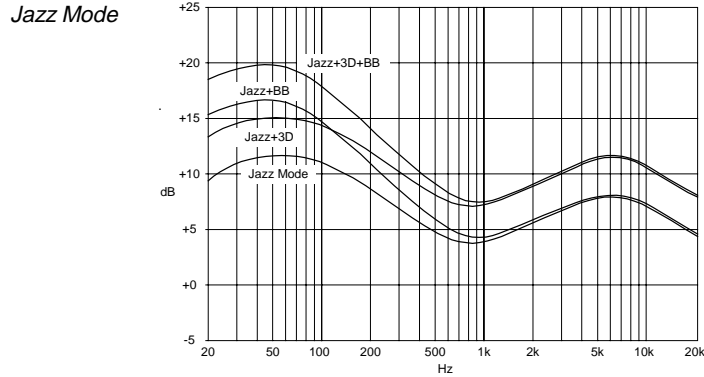

Different sound selections exhibit different frequency gains at different frequency levels. Please refer to the table below:

Sound Selection	Typ.			Unit
	f = 80Hz	f = 1kHz	f = 10kHz	
Flat	3	3	3	dB
Rock	14	6.5	12.5	
Pops	8	6	12.5	
Classic	8.5	7	7.5	
Jazz	14.5	7.5	10.5	
Flat + Bass Booster	10	5	4	
Rock + Bass Booster	18.5	7	12.5	
Pops + Bass Booster	12.5	6.5	12.5	
Classic + Bass Booster	13	7	8	
Jazz + Bass Booster	18.5	7.5	10.5	
Flat + 3D	7	7	7	
Rock + 3D	18	10	16	
Pops + 3D	11.5	9.5	16	
Classic + 3D	12	9.5	11	
Jazz + 3D	18	10.5	14	
Flat + BB + 3D	14	8.5	7.5	
Rock + BB + 3D	22.2	10.5	16.5	
Pops + BB + 3D	16.5	10	16	
Classic + BB + 3D	16.5	10.5	11	
Jazz + BB + 3D	22.5	11	14	

TREBLE AND BASS ADJUSTMENTS

It is general knowledge that different individuals have different listening preferences. The application circuit of SC5389 included in this specification has been designed for the taste general listening public; however, you can make the necessary adjustment to suit your personal taste. Please refer to the sections below.

Treble Adjustment

The Treble adjustment is made by changing the value of the 2 capacitors connected between TL and OUTL. Please refer to the diagram below.

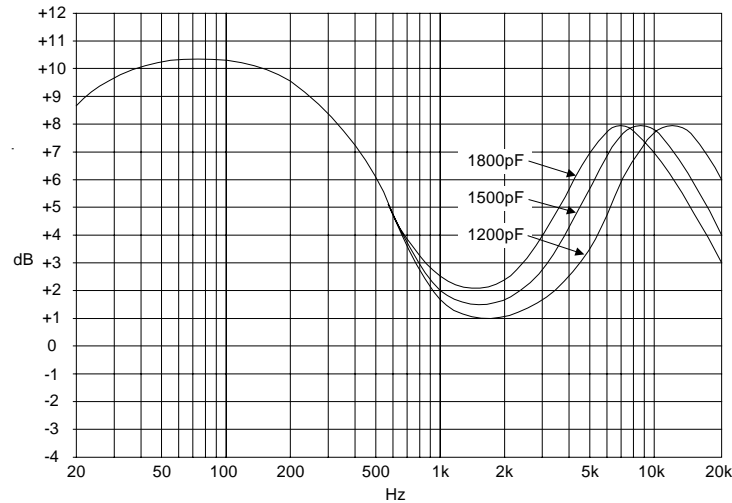

TL-OUTL Capacitors vs. Frequency Response

As the capacitor value becomes bigger, the treble of the gain frequency curve is shifted down. Likewise, as the capacitor value becomes smaller, the treble gain frequency curve shifts the opposite direction. Referring to the diagram above, we see that at 6dB, different capacitor values exhibit different frequency responses. Capacitor value 1800pF has a lower frequency gain response than 1200pF capacitor.

Bass Adjustment

Bass adjustments can be made by changing the values of the capacitors connected between BL1 – BL2 pins, and BR1 – BR2 pins. The larger the capacitor value used, the frequency response curve shifts down. Likewise, the capacitor value, the frequency response curve shifts the opposite direction. Please refer to the diagram below.

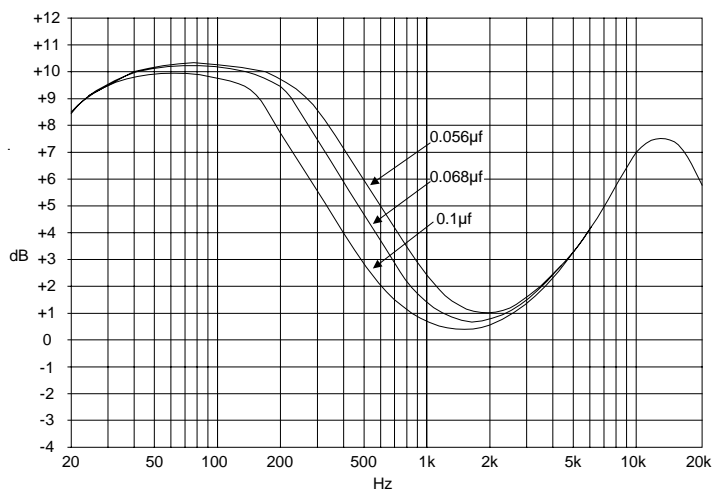

BL1—BL2 Capacitor vs. Frequency Response Curve

In the diagram above, at 9 dB – different capacitor values exhibit different frequency responses. A capacitor with a value of 0.1µf has smaller frequency response than a 0.056µf capacitor.

APPLICATION CIRCUIT

Direct Key Mode

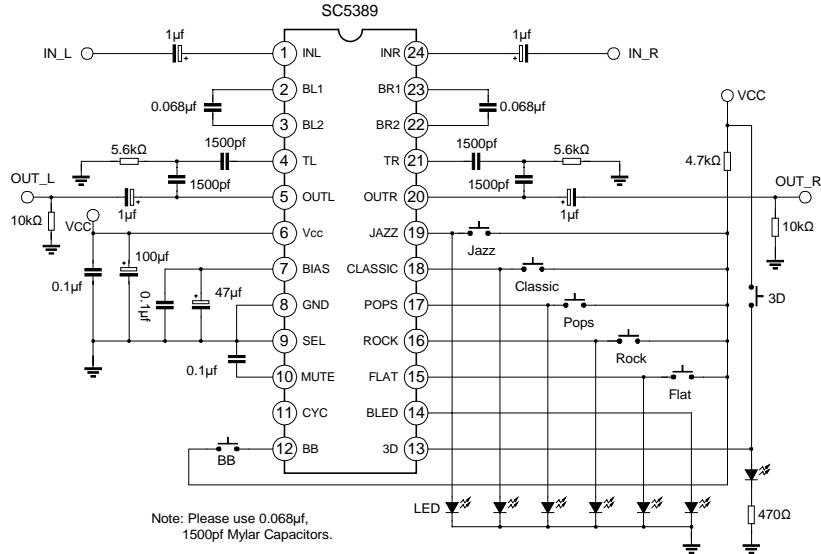

Cyclic Key Mode

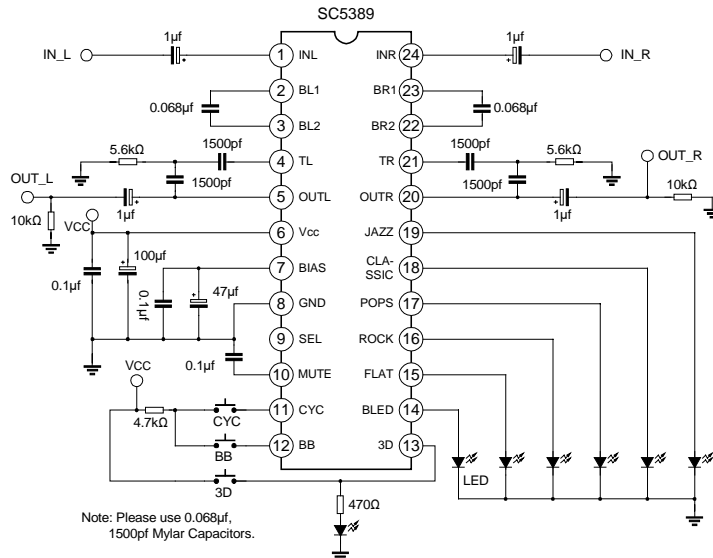

HANGZHOU SILAN MICROELECTRONICS JOINT-STOCK CO.,LTD

Rev: 1.0 2000.12.31

PACKAGE OUTLINE

DIP-24-300-2.54

UNIT:mm

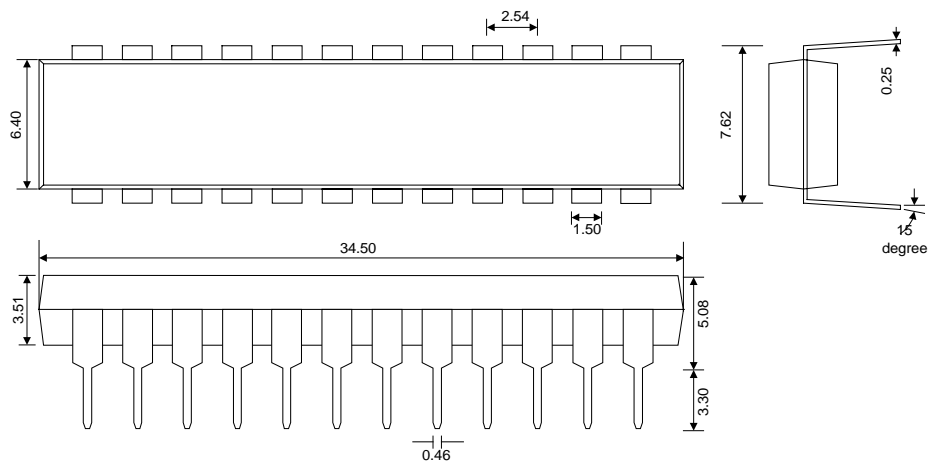

SOP-24-375-1.27

UNIT:mm

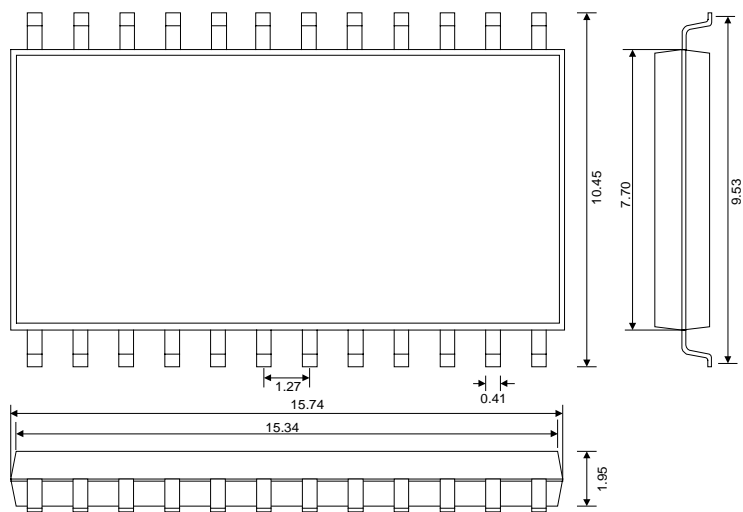

— HANGZHOU SILAN MICROELECTRONICS JOINT-STOCK CO.,LTD —

Rev: 1.0 2000.12.31