



## 78LXX

## LINEAR INTEGRATED CIRCUIT

### 3-TERMINAL 0.1A POSITIVE VOLTAGE REGULATOR

#### DESCRIPTION

The UTC **78LXX** family is monolithic fixed voltage regulator integrated circuit. They are suitable for applications that required supply current up to 100mA.

#### FEATURES

- \* Output current up to 100mA
- \* Fixed output voltage of 5V, 6V, 8V, 9V, 10V, 12V, 15V, 18V and 24V available
- \* Thermal overload shutdown protection
- \* Short circuit current limiting

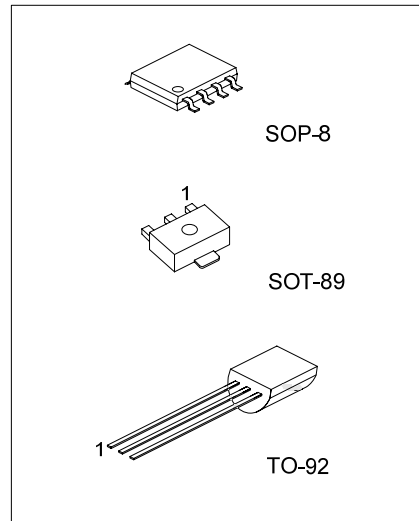

\* Pb-free plating product number: 78LXXL

#### ORDERING INFORMATION

Order Number		Pin Assignment								Package	Packing
Normal	Lead Free Plating	1	2	3	4	5	6	7	8		
78Lxx-AB3-R	78LxxL-AB3-R	O	G	I	-	-	-	-	-	SOT-89	Tape Reel
78Lxx-S08-R	78LxxL-S08-R	O	G	G	N	N	G	G	I	SOP-8	Tape Reel
78Lxx-S08-T	78LxxL-S08-T	O	G	G	N	N	G	G	I	SOP-8	Tube
78Lxx-T92-B	78LxxL-T92-B	O	G	I	-	-	-	-	-	TO-92	Tape Box
78Lxx-T92-K	78LxxL-T92-K	O	G	I	-	-	-	-	-	TO-92	Bulk
78Lxx-T92-R	78LxxL-T92-R	O	G	I	-	-	-	-	-	TO-92	Tape Reel

Note: 1. xx: Output Voltage, refer to Marking Information.

2. O: Output G: GND I: Input N: No Connection

<p>78LxxL-AB3-R</p>	<p>(1) Packing Type (2) Package Type (3) Lead Plating (4) Output Voltage Code</p>	<p>(1) B: Tape Box, K: Bulk, R: Tape Reel, T: Tube (2) AB3: SOT-89, S08: SOP-8, T92: TO-92 (3) L: Lead Free Plating, Blank: Pb/Sn (4) xx: refer to Marking Information</p>
---------------------	---	--

### MARKING INFORMATION

PACKAGE	VOLTAGE CODE	MARKING
SOP-8	05:5.0V 06:6.0V 08:8.0V 09:9.0V 10:10V 12:12V 15:15V 18:18V 24:24V	<p>Diagram of an SOP-8 package. The top surface is marked with 'UTC' followed by three squares, and '78L' followed by three squares. Arrows point from these markings to 'DATE CODE' and 'LEAD PLATING'. A 'VOLTAGE CODE' arrow points to the three squares following '78L'.</p>
SOT-89		<p>Diagram of an SOT-89 package. The top surface is marked with '78L' followed by three squares. Arrows point from these markings to 'DATE CODE' and 'LEAD PLATING'. A 'VOLTAGE CODE' arrow points to the three squares following '78L'. The package has three leads labeled 1, 2, and 3.</p>
TO-92		<p>Diagram of a TO-92 package. The top surface is marked with 'UTC' followed by three squares, and '78L' followed by three squares. Arrows point from these markings to 'LEAD PLATING' and 'DATE CODE'. A 'VOLTAGE CODE' arrow points to the three squares following '78L'. The package has one lead labeled 1.</p>

### ■ ABSOLUTE MAXIMUM RATINGS

PARAMETER		SYMBOL	RATINGS	UNIT
Input voltage	$V_{OUT}=5\sim 9V$	$V_{IN}$	30	V
	$V_{OUT}=12\sim 24V$		35	
Output Current		$I_{OUT}$	100	mA
Power Dissipation	SOP-8	$P_D$	300	mW
	TO-92		625	
	SOT-89		350	
Junction Temperature		$T_J$	+125	°C
Operating Temperature		$T_{OPR}$	-20~+150	°C
Storage Temperature		$T_{STG}$	-55~+150	°C

Note Absolute maximum ratings are those values beyond which the device could be permanently damaged. Absolute maximum ratings are stress ratings only and functional device operation is not implied.

### ■ ELECTRICAL CHARACTERISTICS

For UTC78L05 ( $V_{IN}=10V$ ,  $I_{OUT}=40mA$ ,  $0^\circ C < T_J < 125^\circ C$ ,  $C1=0.33\mu F$ ,  $C0=0.1\mu F$ , unless otherwise specified)

PARAMETER	SYMBOL	TEST CONDITIONS	MIN	TYP	MAX	UNIT
Output Voltage	$V_{OUT}$	$T_J=25^\circ C$	4.80	5.0	5.20	V
		$7V \leq V_{IN} \leq 20V, I_{OUT}=1mA-40mA$	4.75		5.25	V
		$7V \leq V_{IN} \leq V_{MAX}, I_{OUT}=1mA-70mA$	4.75		5.25	V (note 2)
Load Regulation	$\Delta V_{OUT}$	$T_J=25^\circ C, I_{OUT}=1mA-100mA$		11	60	mV
		$T_J=25^\circ C, I_{OUT}=1mA-40mA$		5.0	30	mV
Line regulation	$\Delta V_{OUT}$	$7V \leq V_{IN} \leq 20V, T_J=25^\circ C$		8	150	mV
		$8V \leq V_{IN} \leq 20V, T_J=25^\circ C$		6	100	mV
Quiescent Current	$I_Q$	$V_{IN}=10V, I_{OUT}=0mA, T_J=25^\circ C$		2.0	5.5	mA
Quiescent Current Change	$\Delta I_Q$	$8V \leq V_{IN} \leq 20V$			1.5	mA
		$1mA \leq V_{IN} \leq 40mA$			0.1	mA
Output Noise Voltage	eN	$10Hz \leq f \leq 100kHz$		40		uV
Temperature coefficient of $V_{OUT}$	$\Delta V_O/\Delta T$	$I_{OUT}=5mA$		-0.65		mV/°C
Ripple Rejection	RR	$8V \leq V_{IN} \leq 20V, f=120Hz, T_J=25^\circ C$	41	80		dB
Dropout Voltage	$V_D$	$T_J=25^\circ C$		1.7		V

For UTC78L06 ( $V_{IN}=12V$ ,  $I_{OUT}=40mA$ ,  $0^\circ C < T_J < 125^\circ C$ ,  $C1=0.33\mu F$ ,  $C0=0.1\mu F$ , unless otherwise specified)

PARAMETER	SYMBOL	TEST CONDITIONS	MIN	TYP	MAX	UNIT
Output Voltage	$V_{OUT}$	$T_J=25^\circ C$	5.76	6.0	6.24	V
		$8.5V \leq V_{IN} \leq 20V, I_{OUT}=1mA-40mA$	5.70		6.30	V
		$8.5V \leq V_{IN} \leq V_{MAX}, I_{OUT}=1mA-70mA$	5.70		6.30	V (note 2)
Load Regulation	$\Delta V_{OUT}$	$T_J=25^\circ C, I_{OUT}=1mA-100mA$		12.8	80	mV
		$T_J=25^\circ C, I_{OUT}=1mA-70mA$		5.8	40	mV
Line regulation	$\Delta V_{OUT}$	$8.5V \leq V_{IN} \leq 20V, T_J=25^\circ C$		64	175	mV
		$9V \leq V_{IN} \leq 20V, T_J=25^\circ C$		54	125	mV
Quiescent Current	$I_Q$	$V_{IN}=12V, I_{OUT}=0mA, T_J=25^\circ C$		3.9	6.0	mA
Quiescent Current Change	$\Delta I_Q$	$9V \leq V_{IN} \leq 20V$			1.5	mA
		$1mA \leq V_{IN} \leq 40mA$			0.1	mA
Output Noise Voltage	eN	$10Hz \leq f \leq 100kHz$		49		uV
Temperature coefficient of $V_{OUT}$	$\Delta V_O/\Delta T$	$I_{OUT}=5mA$		-0.75		mV/°C
Ripple Rejection	RR	$10V \leq V_{IN} \leq 20V, f=120Hz, T_J=25^\circ C$	40	46		dB
Dropout Voltage	$V_D$	$T_J=25^\circ C$		1.7		V

■ ELECTRICAL CHARACTERISTICS (Cont.)

For UTC78L08 ( $V_{IN}=14V$ ,  $I_{OUT}=40mA$ ,  $0^{\circ}C < T_J < 125^{\circ}C$ ,  $C_1=0.33\mu F$ ,  $C_o=0.1\mu F$ , unless otherwise specified)

PARAMETER	SYMBOL	TEST CONDITIONS	MIN	TYP	MAX	UNIT
Output Voltage	$V_{OUT}$	$T_J=25^{\circ}C$	7.68	8.0	8.32	V
		$10.5V \leq V_{IN} \leq 23V, I_{OUT}=1mA-40mA$	7.60		8.40	V
		$10.5V \leq V_{IN} \leq V_{MAX}, I_{OUT}=1mA-70mA$	7.60		8.40	V(note 2)
Load Regulation	$\Delta V_{OUT}$	$T_J=25^{\circ}C, I_{OUT}=1mA-100mA$		15	80	mV
		$T_J=25^{\circ}C, I_{OUT}=1mA-70mA$		8.0	40	mV
Line regulation	$\Delta V_{OUT}$	$10.5V \leq V_{IN} \leq 23V, T_J=25^{\circ}C$		10	175	mV
		$11V \leq V_{IN} \leq 23V, T_J=25^{\circ}C$		8	125	mV
Quiescent Current	$I_Q$	$V_{IN}=14V, I_{OUT}=0mA, T_J=25^{\circ}C$		2.0	5.5	mA
Quiescent Current Change	$\Delta I_Q$	$11V \leq V_{IN} \leq 23V$			1.5	mA
		$1mA \leq V_{IN} \leq 40mA$			0.1	mA
Output Noise Voltage	eN	$10Hz \leq f \leq 100kHz$		49		$\mu V$
Temperature coefficient of $V_o$	$\Delta V_o/\Delta T$	$I_{OUT}=5mA$		-0.75		$mV/^{\circ}C$
Ripple Rejection	RR	$11V \leq V_{IN} \leq 23V, f=120Hz, T_J=25^{\circ}C$	39	70		dB
Dropout Voltage	$V_D$	$T_J=25^{\circ}C$		1.7		V

For UTC78L09 ( $V_{IN}=15V$ ,  $I_{OUT}=40mA$ ,  $0^{\circ}C < T_J < 125^{\circ}C$ ,  $C_1=0.33\mu F$ ,  $C_o=0.1\mu F$ , unless otherwise specified)

PARAMETER	SYMBOL	TEST CONDITIONS	MIN	TYP	MAX	UNIT
Output Voltage	$V_{OUT}$	$T_J=25^{\circ}C$	8.64	9.0	9.36	V
		$11.5V \leq V_{IN} \leq 24V, I_{OUT}=1mA-40mA$	8.55		9.45	V
		$11.5V \leq V_{IN} \leq V_{MAX}, I_{OUT}=1mA-70mA$	8.55		9.45	V(note 2)
Load Regulation	$\Delta V_{OUT}$	$T_J=25^{\circ}C, I_{OUT}=1mA-100mA$		20	90	mV
		$T_J=25^{\circ}C, I_{OUT}=1mA-40mA$		10	45	mV
Line regulation	$\Delta V_{OUT}$	$11.5V \leq V_{IN} \leq 24V, T_J=25^{\circ}C$		90	200	mV
		$13V \leq V_{IN} \leq 24V, T_J=25^{\circ}C$		100	150	mV
Quiescent Current	$I_Q$	$V_{IN}=15V, I_{OUT}=0mA, T_J=25^{\circ}C$		2.0	6.0	mA
Quiescent Current Change	$\Delta I_Q$	$13V \leq V_{IN} \leq 24V$			1.5	mA
		$1mA \leq V_{IN} \leq 40mA$			0.1	mA
Output Noise Voltage	eN	$10Hz \leq f \leq 100kHz$		70		$\mu V$
Temperature coefficient of $V_{OUT}$	$\Delta V_o/\Delta T$	$I_{OUT}=5mA$		-0.75		$mV/^{\circ}C$
Ripple Rejection	RR	$12V \leq V_{IN} \leq 24V, f=120Hz, T_J=25^{\circ}C$	38	44		dB
Dropout Voltage	$V_D$	$T_J=25^{\circ}C$		1.7		V

For UTC78L10 ( $V_{IN}=16V$ ,  $I_{OUT}=40mA$ ,  $0^{\circ}C < T_J < 125^{\circ}C$ ,  $C_1=0.33\mu F$ ,  $C_o=0.1\mu F$ , unless otherwise specified)

PARAMETER	SYMBOL	TEST CONDITIONS	MIN	TYP	MAX	UNIT
Output Voltage	$V_{OUT}$	$T_J=25^{\circ}C$	9.6	10.0	10.4	V
		$12.5V \leq V_{IN} \leq 25V, I_{OUT}=1mA-40mA$	9.5		10.5	V
		$12.5V \leq V_{IN} \leq V_{MAX}, I_{OUT}=1mA-70mA$	9.5		10.5	V(note 2)
Load Regulation	$\Delta V_{OUT}$	$T_J=25^{\circ}C, I_{OUT}=1mA-100mA$		20	94	mV
		$T_J=25^{\circ}C, I_{OUT}=1mA-70mA$		10	47	mV
Line regulation	$\Delta V_{OUT}$	$12.5V \leq V_{IN} \leq 25V, T_J=25^{\circ}C$		100	200	mV
		$14V \leq V_{IN} \leq 25V, T_J=25^{\circ}C$		100	170	mV
Quiescent Current	$I_Q$	$V_{IN}=17V, I_{OUT}=0mA, T_J=25^{\circ}C$		2.0	6.0	mA
Quiescent Current Change	$\Delta I_Q$	$12.5V \leq V_{IN} \leq 25V$			1.5	mA
		$1mA \leq V_{IN} \leq 40mA$			0.1	mA
Output Noise Voltage	eN	$10Hz \leq f \leq 100kHz$		74		$\mu V$
Temperature coefficient of $V_{OUT}$	$\Delta V_o/\Delta T$	$I_{OUT}=5mA$		-0.8		$mV/^{\circ}C$
Ripple Rejection	RR	$15V \leq V_{IN} \leq 25V, f=120Hz, T_J=25^{\circ}C$	38	43		dB
Dropout Voltage	$V_D$	$T_J=25^{\circ}C$		1.7		V

■ ELECTRICAL CHARACTERISTICS (Cont.)

For UTC78L12 ( $V_{IN}=19V$ ,  $I_{OUT}=40mA$ ,  $0^{\circ}C < T_J < 125^{\circ}C$ ,  $C1=0.33\mu F$ ,  $Co=0.1\mu F$ , unless otherwise specified)

PARAMETER	SYMBOL	TEST CONDITIONS	MIN	TYP	MAX	UNIT
Output Voltage	$V_{OUT}$	$T_J=25^{\circ}C$	11.52	12.0	12.48	V
		$14.5V \leq V_{IN} \leq 27V, I_{OUT}=1mA-40mA$	11.40		12.60	V
		$14.5V \leq V_{IN} \leq V_{MAX}, I_{OUT}=1mA-70mA$	11.40		12.60	V(note 2)
Load Regulation	$\Delta V_{OUT}$	$T_J=25^{\circ}C, I_{OUT}=1mA-100mA$		25	150	mV
		$T_J=25^{\circ}C, I_{OUT}=1mA-40mA$		12	75	mV
Line regulation	$\Delta V_{OUT}$	$14.5V \leq V_{IN} \leq 27V, T_J=25^{\circ}C$		25	300	mV
		$16V \leq V_{IN} \leq 27V, T_J=25^{\circ}C$		20	250	mV
Quiescent Current	$I_Q$	$V_{IN}=19V, I_{OUT}=0mA, T_J=25^{\circ}C$		2.0	6.0	mA
Quiescent Current Change	$\Delta I_Q$	$16V \leq V_{IN} \leq 27V$			1.5	mA
		$1mA \leq V_{IN} \leq 40mA$			0.1	mA
Output Noise Voltage	eN	$10Hz \leq f \leq 100kHz$		80		$\mu V$
Temperature coefficient of $V_{OUT}$	$\Delta V_O/\Delta T$	$I_{OUT}=5mA$		-1.0		$mV/^{\circ}C$
Ripple Rejection	RR	$15V \leq V_{IN} \leq 25V, f=120Hz, T_J=25^{\circ}C$	37	65		dB
Dropout Voltage	$V_D$	$T_J=25^{\circ}C$		1.7		V

For UTC78L15 ( $V_{IN}=23V$ ,  $I_{OUT}=40mA$ ,  $0^{\circ}C < T_J < 125^{\circ}C$ ,  $C1=0.33\mu F$ ,  $Co=0.1\mu F$ , unless otherwise specified)

PARAMETER	SYMBOL	TEST CONDITIONS	MIN	TYP	MAX	UNIT
Output Voltage	$V_{OUT}$	$T_J=25^{\circ}C$	14.40	15.0	15.60	V
		$17.5V \leq V_{IN} \leq 30V, I_{OUT}=1mA-40mA$	14.25		15.75	V
		$17.5V \leq V_{IN} \leq V_{MAX}, I_{OUT}=1mA-70mA$	14.25		15.75	V(note 2)
Load Regulation	$\Delta V_{OUT}$	$T_J=25^{\circ}C, I_{OUT}=1mA-100mA$		20	150	mV
		$T_J=25^{\circ}C, I_{OUT}=1mA-70mA$		25	150	mV
Line regulation	$\Delta V_{OUT}$	$17.5V \leq V_{IN} \leq 30V, T_J=25^{\circ}C$		25	150	mV
		$20V \leq V_{IN} \leq 30V, T_J=25^{\circ}C$		15	75	mV
Quiescent Current	$I_Q$	$V_{IN}=23V, I_{OUT}=0mA, T_J=25^{\circ}C$		2.2	6.5	mA
Quiescent Current Change	$\Delta I_Q$	$20V \leq V_{IN} \leq 30V$			1.5	mA
		$1mA \leq V_{IN} \leq 40mA$			0.1	mA
Output Noise Voltage	eN	$10Hz \leq f \leq 100kHz$		90		$\mu V$
Temperature coefficient of $V_{OUT}$	$\Delta V_O/\Delta T$	$I_{OUT}=5mA$		-1.3		$mV/^{\circ}C$
Ripple Rejection	RR	$18.5V \leq V_{IN} \leq 28.5V, f=120Hz, T_J=25^{\circ}C$	34	63		dB
Dropout Voltage	$V_D$	$T_J=25^{\circ}C$		1.7		V

For UTC78L18 ( $V_{IN}=27V$ ,  $I_{OUT}=40mA$ ,  $0^{\circ}C < T_J < 125^{\circ}C$ ,  $C1=0.33\mu F$ ,  $Co=0.1\mu F$ , unless otherwise specified)

PARAMETER	SYMBOL	TEST CONDITIONS	MIN	TYP	MAX	UNIT
Output Voltage	$V_{OUT}$	$T_J=25^{\circ}C$	17.28	18.0	18.72	V
		$21V \leq V_{IN} \leq 33V, I_{OUT}=1mA-40mA$	17.10		18.90	V
		$21V \leq V_{IN} \leq V_{MAX}, I_{OUT}=1mA-70mA$	17.10		18.90	V(note 2)
Load Regulation	$\Delta V_{OUT}$	$T_J=25^{\circ}C, I_{OUT}=1mA-100mA$		30	170	mV
		$T_J=25^{\circ}C, I_{OUT}=1mA-40mA$		15	85	mV
Line regulation	$\Delta V_{OUT}$	$21V \leq V_{IN} \leq 33V, T_J=25^{\circ}C$		145	300	mV
		$22V \leq V_{IN} \leq 33V, T_J=25^{\circ}C$		135	250	mV
Quiescent Current	$I_Q$	$V_{IN}=27V, I_{OUT}=0mA, T_J=25^{\circ}C$		2.0	6.0	mA
Quiescent Current Change	$\Delta I_Q$	$21V \leq V_{IN} \leq 33V$			1.5	mA
		$1mA \leq V_{IN} \leq 40mA$			0.1	mA
Output Noise Voltage	eN	$10Hz \leq f \leq 100kHz$		150		$\mu V$
Temperature coefficient of $V_{OUT}$	$\Delta V_O/\Delta T$	$I_{OUT}=5mA$		-1.8		$mV/^{\circ}C$
Ripple Rejection	RR	$23V \leq V_{IN} \leq 33V, f=120Hz, T_J=25^{\circ}C$	34	48		dB
Dropout Voltage	$V_D$	$T_J=25^{\circ}C$		1.7		V

■ ELECTRICAL CHARACTERISTICS (Cont.)

For UTC78L24 ( $V_{IN}=33V, I_{OUT}=40mA, 0^{\circ}C < T_J < 125^{\circ}C, C_1=0.33\mu F, C_o=0.1\mu F$ , unless otherwise specified)

PARAMETER	SYMBOL	TEST CONDITIONS	MIN	TYP	MAX	UNIT
Output Voltage	$V_{OUT}$	$T_J=25^{\circ}C$	23.04	24.0	24.96	V
		$27V \leq V_{IN} \leq 38V, I_{OUT}=1mA-40mA$	22.8		25.2	V
		$27V \leq V_{IN} \leq V_{MAX}, I_{OUT}=1mA-70mA$	22.8		25.2	V(note 2)
Load Regulation	$\Delta V_{OUT}$	$T_J=25^{\circ}C, I_{OUT}=1mA-100mA$		40	200	mV
		$T_J=25^{\circ}C, I_{OUT}=1mA-40mA$		20	100	mV
Line regulation	$\Delta V_{OUT}$	$27V \leq V_{IN} \leq 38V, T_J=25^{\circ}C$		160	300	mV
		$28V \leq V_{IN} \leq 38V, T_J=25^{\circ}C$		150	250	mV
Quiescent Current	$I_Q$	$V_{IN}=33V, I_{OUT}=0mA, T_J=25^{\circ}C$		2.2	6.0	mA
Quiescent Current Change	$\Delta I_Q$	$27V \leq V_{IN} \leq 38V$			1.5	mA
		$1mA \leq V_{IN} \leq 40mA$			0.1	mA
Output Noise Voltage	eN	$10Hz \leq f \leq 100kHz$		200		$\mu V$
Temperature coefficient of $V_{OUT}$	$\Delta V_O / \Delta T$	$I_{OUT}=5mA$		-2.0		$mV/^{\circ}C$
Ripple Rejection	RR	$27V \leq V_{IN} \leq 38V, f=120Hz, T_J=25^{\circ}C$	34	45		dB
Dropout Voltage	$V_D$	$T_J=25^{\circ}C$		1.7		V

Note 1. The Maximum steady state usable output current is dependent on input voltage, heat sinking, lead length of the package and copper pattern of PCB.

2. Power dissipation < 0.5W

### APPLICATION CIRCUIT

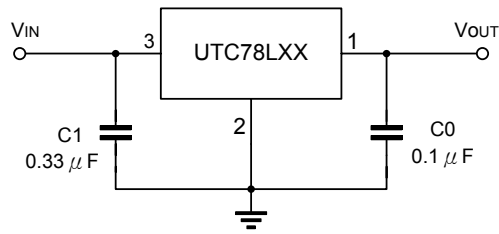

Note 1. To specify an output voltage, substitute voltage value for "XX".

2. Bypass capacitors are recommended for optimum stability and transient response and should be located as close as possible to the regulators.

### TEST CIRCUIT

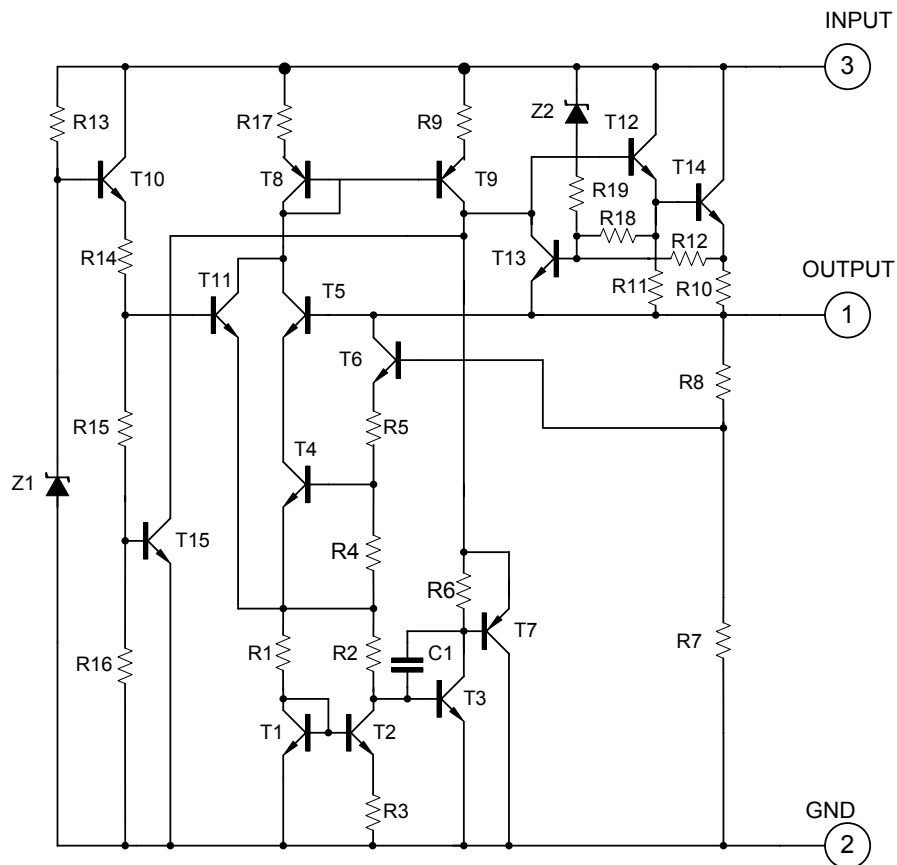

## ■ TYPICAL CHARACTERISTICS

Fig.1 Ambient temperature vs. Power dissipation

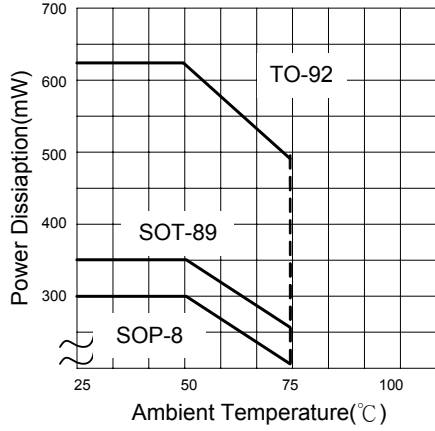

Fig.2 UTC78L05 Output Voltage vs. Ambient temperature

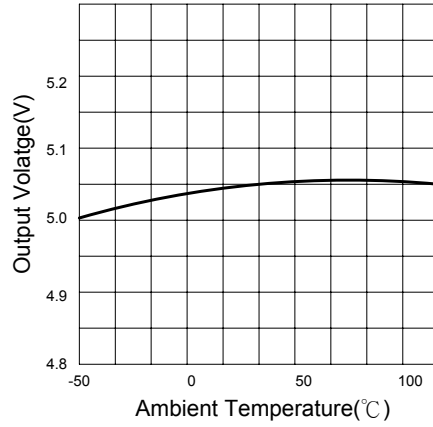

Fig.3 UTC78L12 Output Voltage vs. Ambient temperature

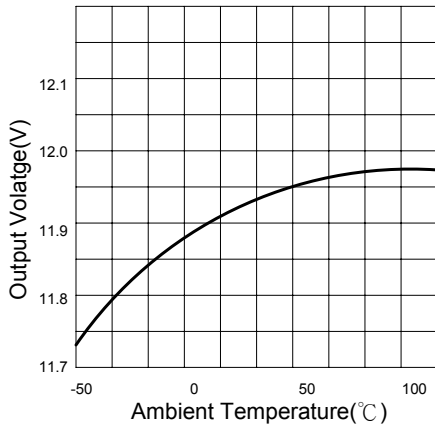

Fig.4 Output Characteristics (I<sub>p</sub>=0mA, T<sub>J</sub>=25°C)

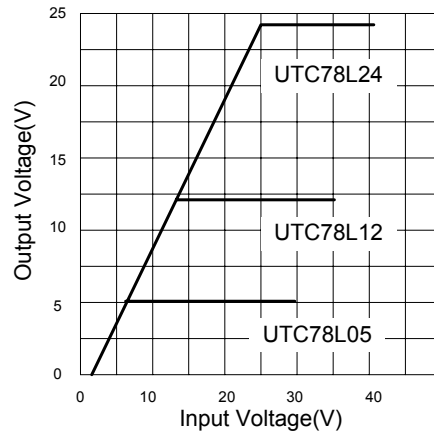

Fig.5 UTC78L05 Dropout Characteristics (T<sub>J</sub>=25°C)

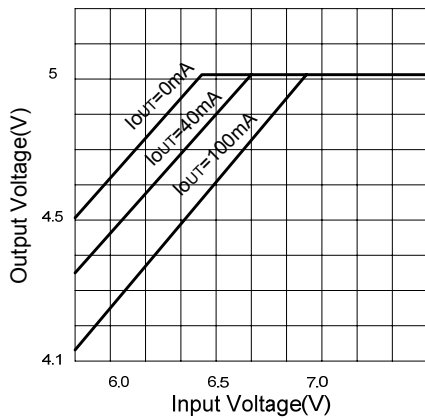
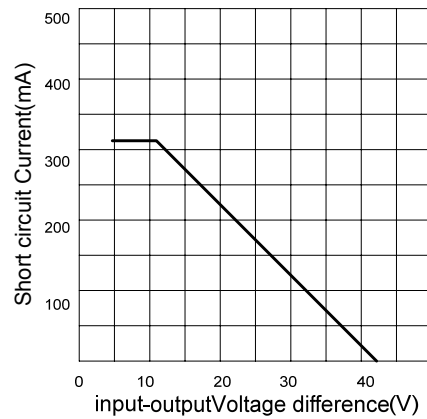

Fig.6 Short Circuit output current (T<sub>J</sub>=25°C)





## ■ TYPICAL CHARACTERISTICS(Cont.)

Fig.7 UTC78L12/24 quiescent current vs output current ( $T_J=25^\circ\text{C}$ )

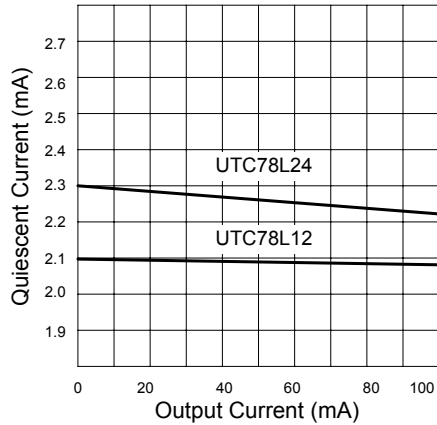

Fig.8 UTC78L05 Quiescent Current vs. Input Voltage ( $I_{OUT}=0\text{mA}, T_J=25^\circ\text{C}$ )

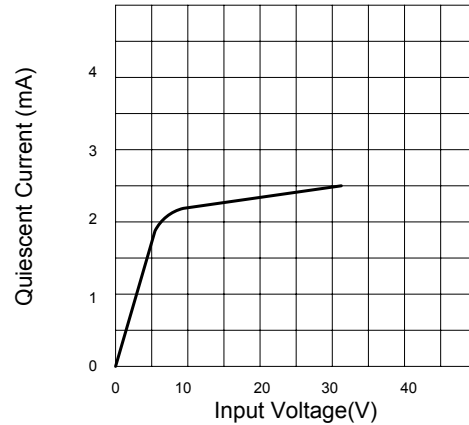

Fig.9 Peak Output Current vs Dropout Voltage Difference

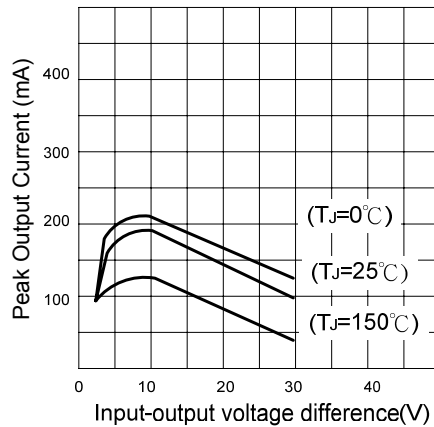
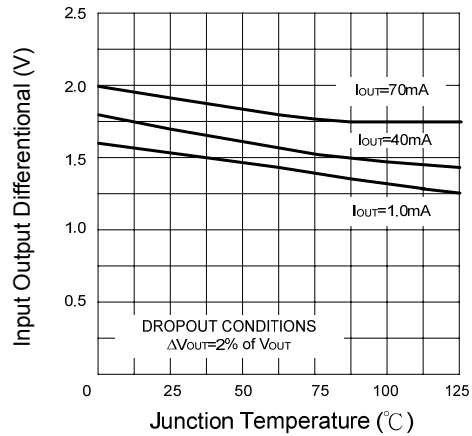

Fig.10 Dropout Voltage



UTC assumes no responsibility for equipment failures that result from using products at values that exceed, even momentarily, rated values (such as maximum ratings, operating condition ranges, or other parameters) listed in products specifications of any and all UTC products described or contained herein. UTC products are not designed for use in life support appliances, devices or systems where malfunction of these products can be reasonably expected to result in personal injury. Reproduction in whole or in part is prohibited without the prior written consent of the copyright owner. The information presented in this document does not form part of any quotation or contract, is believed to be accurate and reliable and may be changed without notice.