



# LC7153, 7153M

## Universal Dual-PLL Frequency Synthesizers



### Overview

The LC7153 and LC7153M are universal dual-PLL frequency synthesizers for use in cordless telephone applications in the USA, South Korea and Australia, and satellite broadcast tuners in the USA and Europe.

The LC7153 and LC7153M both have two PLLs with a 16-bit programmable divider to generate a 1.5 to 160MHz local-oscillator frequency, and a phase detector.

They also have a dual charge pump and fast lock-up circuitry for rapid PLL locking when changing frequency, an unlock indication output and an uncommitted output under external control. The PLLs share a 14-bit divider to generate a 320Hz to 640kHz reference frequency using a 10.24MHz crystal.

The LC7153 and LC7153M can be controlled from an external microcontroller using a C<sup>2</sup>B serial interface.

They also have a standby mode for single PLL operation.

The LC7153 and LC7153M operate from a 4.0 to 5.5V supply. The LC7153 is available in 24-pin DIPs, and the LC7153M, in 24-pin MFPs.

### Features

- Dual charge pump and fast lock-up circuitry for rapid PLL locking.
- PLL unlock indication.
- 16-bit programmable local-oscillator divider.
- 1.5 to 160MHz local-oscillator frequency ( $V_{DD}=4.0$  to 5.5V).
- 14-bit programmable reference-frequency divider.
- 320Hz to 640kHz reference frequency using a 10.24MHz crystal.
- LPF transistor.
- C<sup>2</sup>B serial interface.
- 4.0 to 5.5V supply.
- 24-pin DIP (LC7153) and 24-pin MFP (LC7153M)

- CCB is a trademark of SANYO ELECTRIC CO., LTD.
- CCB is SANYO's original bus format and all the bus addresses are controlled by SANYO.

### Package Dimensions

unit:mm

#### 3067A-DIP24S

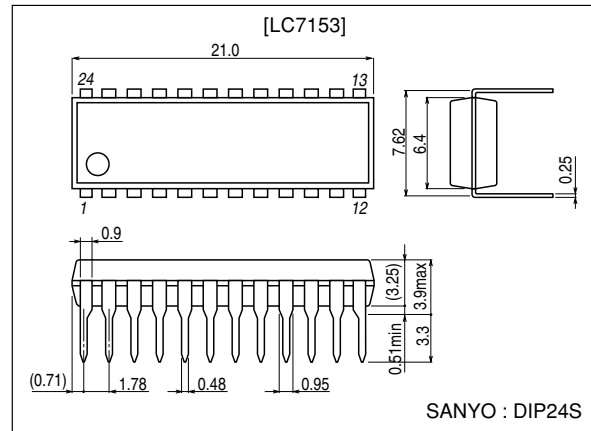

unit:mm

#### 3112A-MFP24S

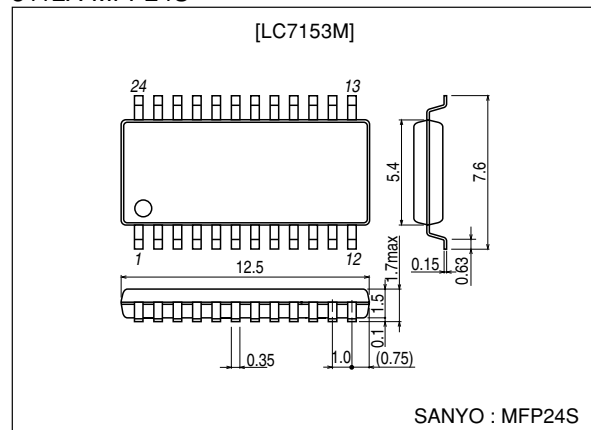

■ Any and all SANYO products described or contained herein do not have specifications that can handle applications that require extremely high levels of reliability, such as life-support systems, aircraft's control systems, or other applications whose failure can be reasonably expected to result in serious physical and/or material damage. Consult with your SANYO representative nearest you before using any SANYO products described or contained herein in such applications.

■ SANYO assumes no responsibility for equipment failures that result from using products at values that exceed, even momentarily, rated values (such as maximum ratings, operating condition ranges, or other parameters) listed in products specifications of any and all SANYO products described or contained herein.

# LC7153, 7153M

## Pin Assignment

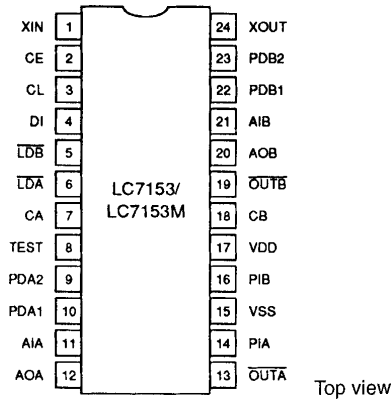

## Block Diagram

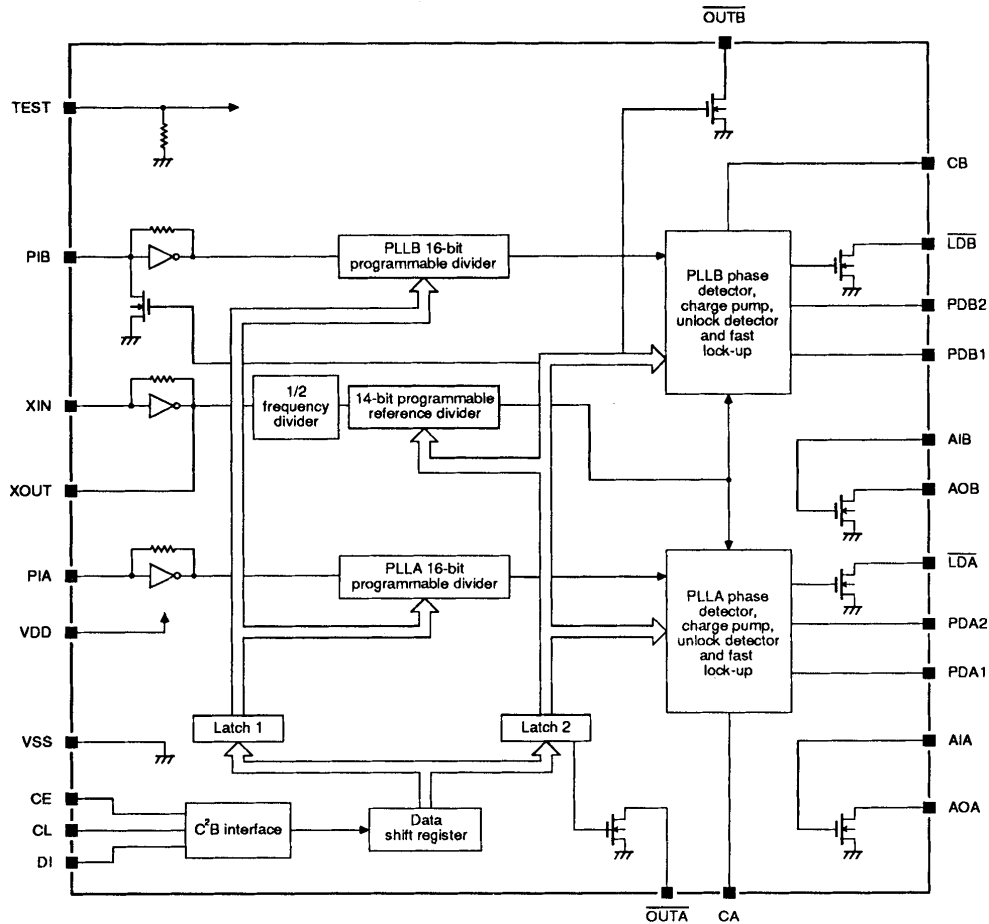

# LC7153, 7153M

## Pin Functions

Number	Name	Function
1	XIN	Crystal oscillator input
2	CE	Chip enable input
3	CL	Clock input
4	DI	Serial data input
5	LDB	PLLB unlock-detector output
6	LDA	PLLA unlock-detector output
7	CA	Fast lock-up capacitor A connection
8	TEST	Test input
9	PDA2	PLLA phase-detector secondary output
10	PDA1	PLLA phase-detector main output
11	AIA	LPF transistor A input
12	AOA	LPF transistor A output
13	OUTA	Uncommitted output A
14	PIA	PLLA local-oscillator input
15	V <sub>SS</sub>	Ground
16	PIB	PLLB local-oscillator input
17	V <sub>DD</sub>	5V supply
18	CB	Fast lock-up capacitor B connection
19	OUTB	Uncommitted output B
20	AOB	LPF transistor B output
21	AIB	LPF transistor B input
22	PDB1	PLLB phase-detector main output
23	PDB2	PLLB phase-detector secondary output
24	XOUT	Crystal oscillator output

## Specifications

### Absolute Maximum Ratings at Ta = 25°C

Parameter	Symbol	Conditions	Ratings	Unit
Supply voltage range	V <sub>DD</sub>		-0.3 to +7.0	V
CE, CL, DI, AIA and AIB input voltage range	V <sub>I1</sub>		-0.3 to +7.0	V
XIN, PIA, PIB, CA, CB and TEST input voltage range	V <sub>I2</sub>		-0.3 to V <sub>DD</sub> +0.3	V
LDA, LDB, OUTA and OUTB output current range	I <sub>O1</sub>		0 to 3	mA
AOA and AOB output current range	I <sub>O2</sub>		0 to 6	mA
CA and CB output current range	I <sub>O3</sub>		0 to 1	mA
LDA and LDB output voltage range	V <sub>O1</sub>		-0.3 to +7.0	V
AOA, AOB, OUTA and OUTB output voltage range	V <sub>O2</sub>		-0.3 to 15.0	V
PDA1, PDA2, PDB1, PDB2, CA, CB and XOUT output voltage range	V <sub>O3</sub>		-0.3 to V <sub>DD</sub> +0.3	V
Allowable power dissipation	Pd max	LC7153	350	mW
		LC7153M	240	mW
Operating temperature	T <sub>opr</sub>		-40 to +85	°C
Storage temperature	T <sub>stg</sub>		-55 to +125	°C

(Note) Pins PIA, PIB, CA and CB have a weaker electrostatic breakdown strength than the other pins.

### Recommended Operating Conditions at Ta = 25°C

Parameter	Symbol	Conditions	Ratings	Unit
Supply voltage	V <sub>DD</sub>		5	V
Supply voltage range	V <sub>DD</sub>		4.0 to 5.5	V

# LC7153, 7153M

**Electrical Characteristics** at Ta = -40 to +85°C, V<sub>DD</sub>=4.0 to 5.5V, V<sub>SS</sub>=0V, unless otherwise noted.

Parameter	Symbol	Conditions	Ratings			Unit
			min	typ	max	
Supply current	I <sub>DD</sub>	V <sub>DD</sub> =4.5V, f <sub>i</sub> =60MHz. See note 1.		9.0	18.0	mA
		V <sub>DD</sub> =5.5V, f <sub>i</sub> =160MHz. See note 1.		20.0	40.0	mA
		V <sub>DD</sub> =4.5V, f <sub>i</sub> =60MHz. See note 2.		5.0	10.0	mA
		V <sub>DD</sub> =5.5V, f <sub>i</sub> =160MHz. See note 2.		11.0	22.0	mA
CE, CL and DI low-level input voltage	V <sub>IL1</sub>		0		0.8	V
CE, CL and DI high-level input voltage	V <sub>IH1</sub>		2.2		5.5	V
PDA1 and PDB1 low-level output voltage	V <sub>OL1</sub>	I <sub>O</sub> =1mA			1.0	V
PDA2 and PDB2 low-level output voltage	V <sub>OL2</sub>	I <sub>O</sub> =2mA			1.0	V
LDA, LDB, OUTA and OUTB low-level output voltage	V <sub>OL3</sub>	I <sub>O</sub> =2mA	0		1.0	V
AOA and AOB low-level output voltage	V <sub>OL4</sub>	I <sub>O</sub> =0.5mA, V <sub>AIA</sub> =V <sub>AIB</sub> =1.2V	0		0.5	V
		I <sub>O</sub> =1mA, V <sub>AIA</sub> =V <sub>AIB</sub> =1.3V	0		0.5	V
PDA1 and PDB1 high-level output voltage	V <sub>OH1</sub>	I <sub>O</sub> =1mA	V <sub>DD</sub> -1			V
PDA2 and PDB2 high-level output voltage	V <sub>OH2</sub>	I <sub>O</sub> =2mA	V <sub>DD</sub> -1			V
LDA and LDB output voltage	V <sub>O1</sub>		0		5.5	V
AOA, AOB, OUTA and OUTB output voltage	V <sub>O2</sub>		0		13.0	V
CA and CB output voltage	V <sub>O3</sub>		0		V <sub>DD</sub>	V
CA and CB low-level threshold voltage	V <sub>T</sub> <sup>-</sup>				0.2V <sub>DD</sub>	V
CA and CB high-level threshold voltage	V <sub>T</sub> <sup>+</sup>		0.5V <sub>DD</sub>			V
CE, CL and DI low-level input current	I <sub>IL1</sub>	V <sub>I</sub> =0V			5.0	μA
XIN low-level input current	I <sub>IL2</sub>	V <sub>I</sub> =0V, V <sub>DD</sub> =5.0V	3.5		11	μA
PIA and PIB low-level input current	I <sub>IL3</sub>	V <sub>I</sub> =0V, V <sub>DD</sub> =5.0V	6.0		18.0	μA
AIA and AIB low-level input current	I <sub>IL4</sub>	V <sub>I</sub> =0V		0.01	10.0	nA
TEST low-level input current	I <sub>IL5</sub>	V <sub>I</sub> =0V, V <sub>DD</sub> =5.0V			5.0	μA
CE, CL and DI high-level input current	I <sub>IH1</sub>	V <sub>I</sub> =5.5V			5.0	μA
XIN high-level input current	I <sub>IH2</sub>	V <sub>I</sub> =5.0V, V <sub>DD</sub> =5.0V	3.5		11.0	μA
PIA and PIB high-level input current	I <sub>IH3</sub>	V <sub>I</sub> =5.0V, V <sub>DD</sub> =5.0V	6.0		18.0	μA
AIA and AIB high-level input current	I <sub>IH4</sub>	V <sub>I</sub> =5.0V		0.01	10.0	nA
TEST high-level input current	I <sub>IH5</sub>	V <sub>I</sub> =5.0V, V <sub>DD</sub> =5.0V		160		μA
LDA and LDB output leakage current	I <sub>OFF1</sub>	V <sub>O</sub> =5.5V			5.0	μA
PDA1, PDB1, PDA2 and PDB2 output leakage current	I <sub>OFF2</sub>	V <sub>O</sub> =0 or 5.5V		0.01	10.0	nA
AOA, AOB, OUTA and OUTB output leakage current	I <sub>OFF3</sub>	V <sub>O</sub> =13V			5.0	μA
CA and CB output leakage current	I <sub>OFF4</sub>	V <sub>O</sub> =0 V or V <sub>DD</sub>			100	nA
CA and CB source current	I <sub>S1</sub>	V <sub>O</sub> =0V, V <sub>DD</sub> =5.0V	-95	-190	-380	μA
Fast lock-up mode 0 CA and CB sink current	I <sub>S2(0)</sub>	V <sub>O</sub> =3.0V, V <sub>DD</sub> =5.0V	3.5I <sub>S2(3)</sub>	4.0I <sub>S2(3)</sub>	4.5I <sub>S2(3)</sub>	μA
Fast lock-up mode 1 CA and CB sink current	I <sub>S2(1)</sub>	V <sub>O</sub> =3.0V, V <sub>DD</sub> =5.0V	2.5I <sub>S2(3)</sub>	3.0I <sub>S2(3)</sub>	3.4I <sub>S2(3)</sub>	μA
Fast lock-up mode 2 CA and CB sink current	I <sub>S2(2)</sub>	V <sub>O</sub> =3.0V, V <sub>DD</sub> =5.0V	1.5I <sub>S2(3)</sub>	2.0I <sub>S2(3)</sub>	2.4I <sub>S2(3)</sub>	μA
Fast lock-up mode 3 CA and CB sink current	I <sub>S2(3)</sub>	V <sub>O</sub> =3.0V, V <sub>DD</sub> =5.0V	18	35	70	μA
XIN input frequency	f <sub>i1</sub>	Capacitively coupled sine wave	1		13	MHz
PIA and PIB input frequency	f <sub>i2</sub>	Capacitively coupled sine wave, V <sub>DD</sub> =5.0V	1.5		160	MHz
XIN rms input amplitude	V <sub>I1</sub>	Capacitively coupled sine wave	100		800	mV
PIA and PIB rms input amplitude	V <sub>I2</sub>	Capacitively coupled sine wave	70		800	mV
Crystal oscillator frequency	f <sub>XTAL</sub>	C <sub>I</sub> ≤50Ω. See note 3.	4.0	10.24	13.0	MHz
XIN internal feedback resistor	R <sub>f1</sub>	V <sub>DD</sub> =5.0V		0.7		MΩ
PIA and PIB internal feedback resistor	R <sub>f2</sub>	V <sub>DD</sub> =5.0V		430		kΩ
TEST internal pull-down resistor	R <sub>d</sub>	V <sub>DD</sub> =5.0V		30		kΩ
XIN, PIA and PIB input capacitance	C <sub>I</sub>			6.0		pF

## Notes

- Dual PLL, both PLLA and PLLB operating, SB=0, f<sub>XTAL</sub>=10.24MHz, V<sub>PIA</sub>=V<sub>PIB</sub>=70mV, all other inputs=0V, all outputs open.
- Standby mode, PLLB stopped, SB=1, f<sub>XTAL</sub>=10.24MHz, V<sub>PIA</sub>=70mV, all other inputs=0V, all outputs open.
- CI in the crystal impedance. Contact Nihon Denpa Kogyo for further information.

Serial Data Input Timing

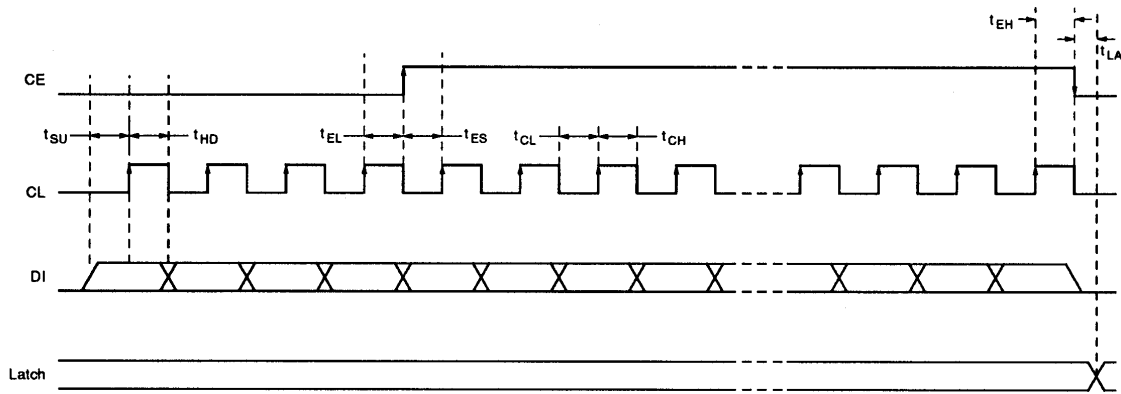

Parameter	Symbol	Conditions	Ratings		Unit
			min	max	
Data setup time	t <sub>SU</sub>	10.24MHz crystal	400		ns
		Other crystal frequencies	4/f <sub>X<sub>TAL</sub></sub>		ns
Data hold time	t <sub>HD</sub>	10.24MHz crystal	400		ns
		Other crystal frequencies	4/f <sub>X<sub>TAL</sub></sub>		ns
LOW-level chip enable time	t <sub>EL</sub>	10.24MHz crystal	400		ns
		Other crystal frequencies	4/f <sub>X<sub>TAL</sub></sub>		ns
Chip enable setup time	t <sub>ES</sub>	10.24MHz crystal	400		ns
		Other crystal frequencies	4/f <sub>X<sub>TAL</sub></sub>		ns
Chip enable hold time	t <sub>EH</sub>	10.24MHz crystal	400		ns
		Other crystal frequencies	4/f <sub>X<sub>TAL</sub></sub>		ns
LOW-level clock pulsewidth	t <sub>CL</sub>	10.24MHz crystal	400		ns
		Other crystal frequencies	4/f <sub>X<sub>TAL</sub></sub>		ns
HIGH-level clock pulsewidth	t <sub>CH</sub>	10.24MHz crystal	400		ns
		Other crystal frequencies	4/f <sub>X<sub>TAL</sub></sub>		ns
Chip enable to data latch time	t <sub>LA</sub>	10.24MHz crystal		400	ns
		Other crystal frequencies		4/f <sub>X<sub>TAL</sub></sub>	ns

Functional Description

PLLA and PLLB Programmable Dividers

PLLA and PLLB input frequency ranges are set by Mode 2 command bits FA and FB, respectively. Their divider ratios, N<sub>A</sub> and N<sub>B</sub>, are set by Mode 1 command bits DA0 to DA15 and DB0 to DB15, respectively.

Programmable Reference Divider

The divider ratio, NR, is set by Mode 2 command bits R0 to R13. The reference frequency is given by f<sub>XIN</sub>/(2×NR).

Phase Detector

The state of the phase-detector output as a function of the divider ratio and reference frequency is shown in table 1. Table 1. Phase-detector output states

Condition	PDA1, PDB1
f <sub>I</sub> /N > f <sub>ref</sub>	HIGH
f <sub>I</sub> /N < f <sub>ref</sub>	LOW
f <sub>I</sub> /N = f <sub>ref</sub>	HIGH impedance

Note

N=N<sub>A</sub> for PLLA, and N<sub>B</sub> for PLLB

When PLLA is unlocked,  $\overline{LDA}$  is pulled LOW and both PDA1 and PDA2 are active. PLLB operates identically to PLLA. Mode 2 command bits UL0 and UL1 set the unlock phase-error threshold, and bits UE0 and UE1, the  $\overline{LDA}$  and  $\overline{LDB}$  output extension.

Dual Charge Pump

A typical dual charge-pump configuration is shown in figure 1. The phase-detector secondary output is active after a change in frequency, and the phase error causes the PLL to unlock. In this case, the load resistance R1 becomes R1||R1S, decreasing the LPF time constant and the time required to lock the PLL.

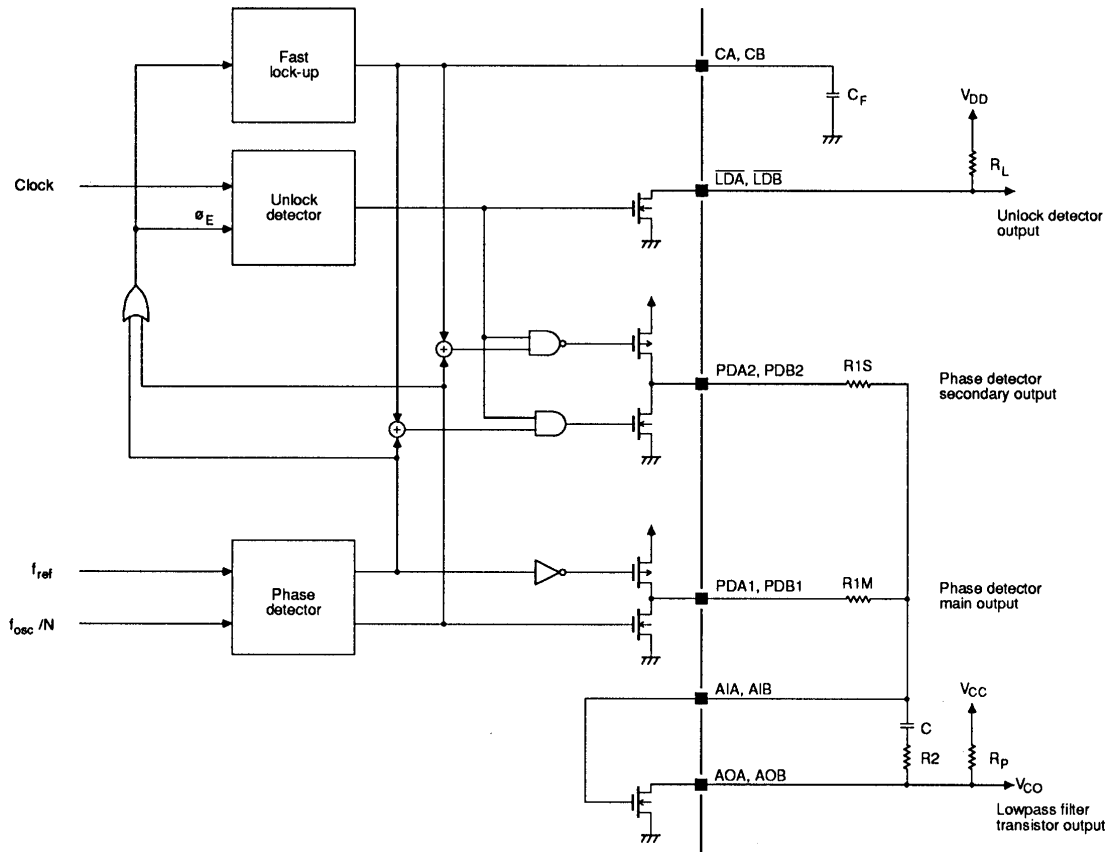

Figure 1. Dual charge-pump circuit

The phase-detector secondary output is high impedance when the PLL is locked. In this case, R1 becomes R1M,

increasing the LPF time constant and improving sideband and modulation response.

**Test Mode**

TEST should be LOW or open for normal operation.

**Serial Input Data**

Serial data should be input only after  $f_{XIN}$  has become stable.

The command format is shown in figure 2. Bits DA0 to DA15 and DB0 to DB15 determine the PLLA and PLLB programmable divider ratios, respectively. Bit DA0 is the first bit received. The range of allowable divider ratios is  $N = 256$  (0100H) to 65535 (FFFFH).

**Mode 1 command format and functions**

The Mode 1 command comprises the data bits which determine the PLLA and PLLB programmable divider ratios.

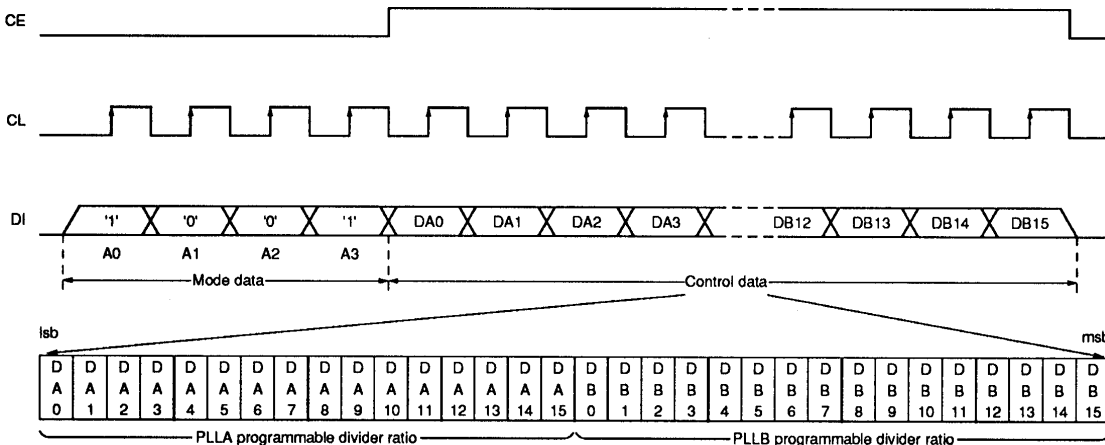

Figure 2. Mode 1 command (programmable divider data)

**Mode 2 command format and functions**

The Mode 2 command comprises the data bits which determine the reference frequency divider ratio and control

functions. The command format is shown in figure 3. Bit R0 is the first bit received.

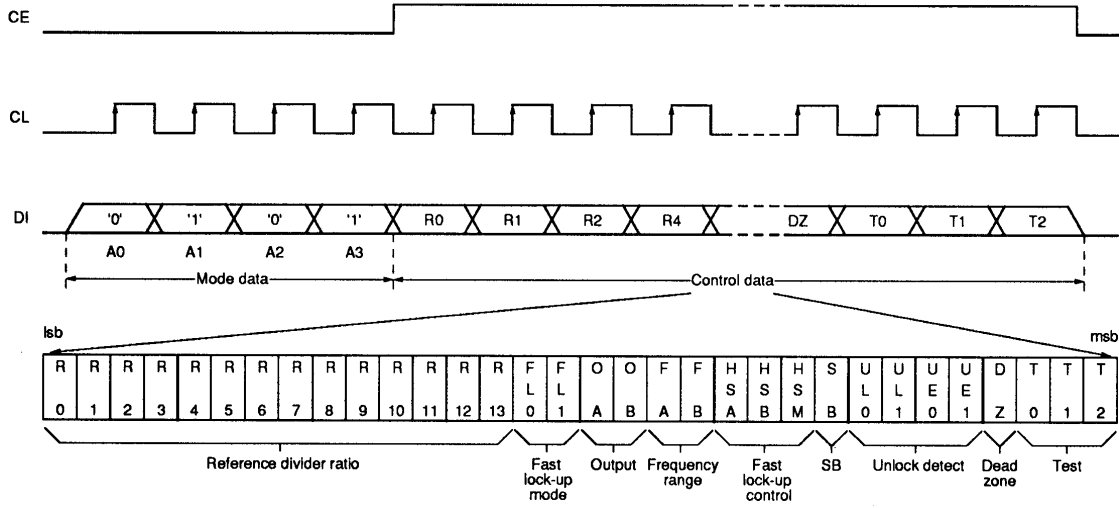

Figure 3. Mode 2 command (reference divider and control data)

Bits R0 to R13 determine the reference divider ratio. The range of allowable divider ratios is  $N_R=8$  (0008H) to 16383 (3FFFH).

Bits FL0 and FL1 are the fast lock-up mode select bits. The fast lock-up modes are shown in table 2. The higher the mode number, the greater the expansion width of the detected phase error signal.

FL0	FL1	Fast lock-up mode
0	0	0
1	0	1
0	1	2
1	1	3

Bits OA and OB are the uncommitted output control bits. They are latched and then inverted to control  $\overline{OUTA}$  and  $\overline{OUTB}$ , respectively. If either bit is 1, the open-drain output is pulled LOW.

Bits FA and FB are the input frequency range select bits. The PIA and PIB frequency ranges, set by FA and FB, respectively, are shown in table 3.

Table 3. Frequency ranges

FA, FB	Input frequency range	Unit
0	1.5 to 40.0	MHz
1	35 to 160	MHz

Bits HSA, HSB and HSM are the fast lock-up control bits. When HSA or HSB=1, the fast lock-up circuits for PLLA or PLLB, respectively, are ON. When HSA or HSB=0, the respective circuits are OFF. For use with FM, the fast lock-up circuits should be OFF. HSM determines the fast lock-up operating mode. When HSM=0, operating mode 0 is selected and the fast lock-up only operates when the PLLs are unlocked. When HSM=1, operating mode 1 is selected and the fast lock-up operates normally, as shown in figure 4.

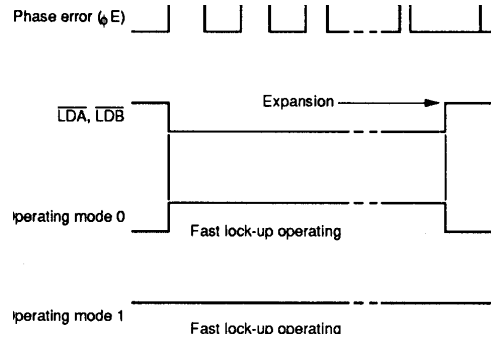

Figure 4. Fast lock-up operating modes

Bit SB is the standby mode control bit. When SB=1, standby mode is selected. In standby mode, PLLB is stopped, PIB is pulled LOW, and PDB1 and PDB2 are high impedance. When SB=0, normal operation is selected.

Bits UL0 and UL1 determine the unlock detection threshold. The PLL unlock detector output,  $\overline{LDA}$  or  $\overline{LDB}$ , is pulled LOW when the phase differential between the reference and the divider inputs exceeds the threshold set by UL0 and UL1. The threshold for different crystal frequencies is shown in table 4, and the threshold for other frequencies can be calculated. The threshold is common to both PLLs. Note that a PLL will temporarily lose lock when either UL0 or UL1 is changed.

Table 4. Unlock detector thresholds

UL0	UL1	$\overline{\text{LDA}}, \overline{\text{LDB}}$ phase error threshold	Example phase error thresholds ( $\mu\text{s}$ )				
			$f_{\text{XIN}}=4\text{MHz}$	$f_{\text{XIN}}=7.2\text{MHz}$	$f_{\text{XIN}}=8\text{MHz}$	$f_{\text{XIN}}=10.24\text{MHz}$	$f_{\text{XIN}}=12.8\text{MHz}$
0	0	0	0	0	0	0	0
1	0	$\pm 4/f_{\text{XIN}}$	$\pm 1.00$	$\pm 0.55$	$\pm 0.50$	$\pm 0.39$	$\pm 0.31$
0	1	$\pm 16/f_{\text{XIN}}$	$\pm 4.00$	$\pm 2.22$	$\pm 2.00$	$\pm 1.56$	$\pm 1.20$
1	1	$\pm 64/f_{\text{XIN}}$	$\pm 16.00$	$\pm 8.88$	$\pm 8.00$	$\pm 6.25$	$\pm 5.00$

Bits UE0 and UE1 determine the unlock extension, or delay, before the unlock detector outputs,  $\overline{\text{LDA}}$  and  $\overline{\text{LDB}}$ , can change state. The extension for different reference frequen-

cies is shown in table 5. However, if a phase-error threshold of zero is set using UL0 and UL1, no output extension occurs.

Table 5.  $\overline{\text{LDA}}, \overline{\text{LDB}}$  output extension

UE0	UE1	$\overline{\text{LDA}}, \overline{\text{LDB}}$ output extension	Example output extensions (ms)		
			$f_{\text{ref}}=1\text{kHz}$	$f_{\text{ref}}=5\text{kHz}$	$f_{\text{ref}}=12.5\text{kHz}$
0	0	$4/f_{\text{ref}}$	4.0 (typ)	0.8	0.32
1	0	$8/f_{\text{ref}}$	8.0	1.6	0.64
0	1	$32/f_{\text{ref}}$	32.0	6.4 (typ)	2.56
1	1	$64/f_{\text{ref}}$	64.0	12.8	5.12 (typ)

Bit DZ is the dead-zone selection bit. It selects the phase-insensitive bandwidth, or dead zone, of the phase comparator. When DZ=1, DZB mode is selected, and when DZ=0, DZA mode. DZB mode has larger dead zone than DZA mode.

Bits T0, T1 and T2 are test bits. They should be set to 0 for normal operation.



# LC7153, 7153M

## Typical Application

A LC7153 or LC7153M cordless telephone application circuit is shown in figure 5. The telephone is tuned to channel 1, which has a transmit VCO frequency of 46.610MHz and a receive VCO frequency of 38.975MHz.

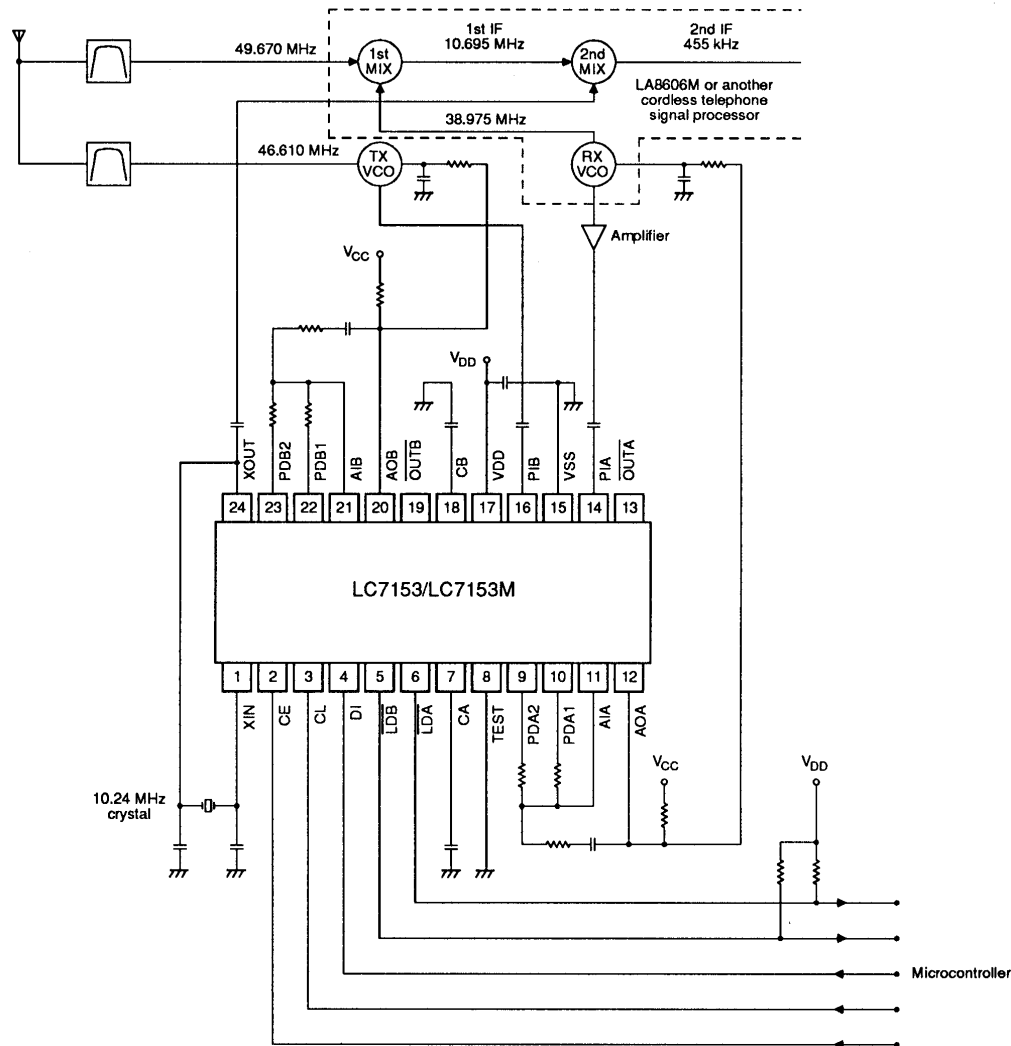

Figure 5. American 10-channel, 46/49 MHz, cordless telephone base station

For  $f_{ref} = 5\text{kHz}$ , the divider ratios are as follows.

$$N_A = \frac{f_{IA}}{f_{ref}} = \frac{\text{RX VCO}}{f_{ref}} = \frac{38.975\text{MHz}}{5\text{kHz}} = 7795 \text{ (1E73H)}$$

$$N_B = \frac{f_{IB}}{f_{ref}} = \frac{\text{TX VCO}}{f_{ref}} = \frac{46.610\text{MHz}}{5\text{kHz}} = 9322 \text{ (246AH)}$$

$$NR = \frac{f_{XIN}}{2 \times f_{ref}} = \frac{10.24\text{MHz}}{2 \times 5\text{kHz}} = 1024 \text{ (400H)}$$

# LC7153, 7153M

The Mode 1 and Mode 2 commands are shown in tables 6 and 7, respectively, and in figures 6 and 7, respectively.

Table 6. Mode 1 command

Field	Value	Comment
DA0 to DA15	1E73H	PLLA divider ratio 7795
DB0 to DB15	246AH	PLLB divider ratio 9322

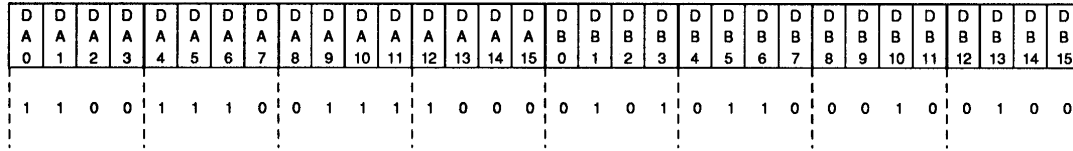

Figure 6. Mode 1 command

Table 7. Mode 2 command

Field	Value	Comment
R0 to R13	0400H	Reference divider ratio of 1024
FL0, FL1	00	Fast lock-up mode 0
OA	0	$\overline{\text{OUTA}}$ and $\overline{\text{OUTB}}$ left open.
OB	0	
FA	1	20 to 55MHz RX VCO input frequency range
FB	1	20 to 55MHz TX VCO input frequency range
HSA, HSB	00	PLLA and PLLB fast lock-up OFF
HSM	0	Fast lock-up operating mode 0
SB	0 or 1	Standby mode selection
UL0, UL1	11	$\pm 6.25\mu\text{s}$ lock/unlock detection threshold
UE0, UE1	01	6.4ms $\overline{\text{LDA}}$ and $\overline{\text{LDB}}$ output extension
DZ	1	DZB dead-zone mode
T0, T1, T2	000	Test mode deselected

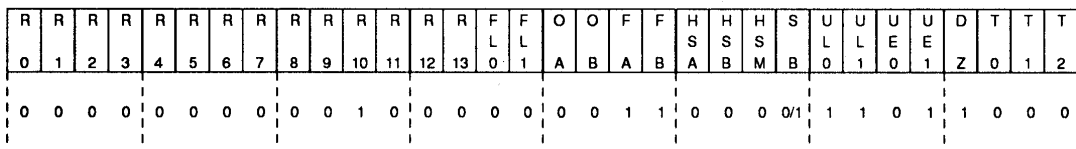

Figure 7. Mode 2 command

- Specifications of any and all SANYO products described or contained herein stipulate the performance, characteristics, and functions of the described products in the independent state, and are not guarantees of the performance, characteristics, and functions of the described products as mounted in the customer's products or equipment. To verify symptoms and states that cannot be evaluated in an independent device, the customer should always evaluate and test devices mounted in the customer's products or equipment.
- SANYO Electric Co., Ltd. strives to supply high-quality high-reliability products. However, any and all semiconductor products fail with some probability. It is possible that these probabilistic failures could give rise to accidents or events that could endanger human lives, that could give rise to smoke or fire, or that could cause damage to other property. When designing equipment, adopt safety measures so that these kinds of accidents or events cannot occur. Such measures include but are not limited to protective circuits and error prevention circuits for safe design, redundant design, and structural design.
- In the event that any or all SANYO products(including technical data, services) described or contained herein are controlled under any of applicable local export control laws and regulations, such products must not be exported without obtaining the export license from the authorities concerned in accordance with the above law.
- No part of this publication may be reproduced or transmitted in any form or by any means, electronic or mechanical, including photocopying and recording, or any information storage or retrieval system, or otherwise, without the prior written permission of SANYO Electric Co., Ltd.
- Any and all information described or contained herein are subject to change without notice due to product/technology improvement, etc. When designing equipment, refer to the "Delivery Specification" for the SANYO product that you intend to use.
- Information (including circuit diagrams and circuit parameters) herein is for example only ; it is not guaranteed for volume production. SANYO believes information herein is accurate and reliable, but no guarantees are made or implied regarding its use or any infringements of intellectual property rights or other rights of third parties.

This catalog provides information as of July, 2001. Specifications and information herein are subject to change without notice.