

1.5A ADJUSTABLE/FIXED LOW DROPOUT LINEAR REGULATOR**DESCRIPTION**

The @vic AV1086 and AV1086-1.8V, 2.5V, 2.85V, 3.3V and 5V are low dropout three-terminal regulators with 1.5A output current capability. These devices have been optimized for low voltage where transient response and minimum input voltage are critical. The 2.85V version is designed specifically to be used in Active Terminators for SCSI bus.

Current limit is trimmed to ensure specified output current and controlled short-circuit current. On-chip thermal limiting provides protection against any combination of overload and ambient temperatures that would create excessive junction temperatures.

Unlike PNP type regulators where up to 10% of the output current is wasted as quiescent current, the quiescent current of the UZ1086 flows into the load, increasing efficiency.

FEATURES

- *Low dropout voltage
- *Load regulation: 0.05% typical
- *Trimmed current limit
- *On-chip thermal limiting
- *Three-terminal adjustable or fixed 1.8V, 2.5V, 2.85V, 3.3V, 5V

APPLICATIONS

- *Active SCSI terminators
- *High efficiency linear regulators
- *Post regulators for switching supplies
- *Battery charges
- *5V to 3.3V linear regulators
- *Motherboard clock supplies

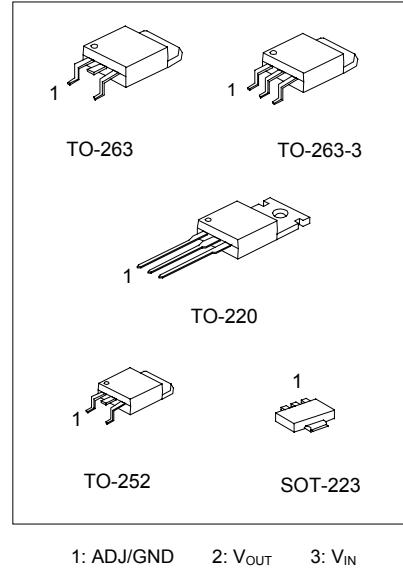

TYPICAL APPLICATIONS

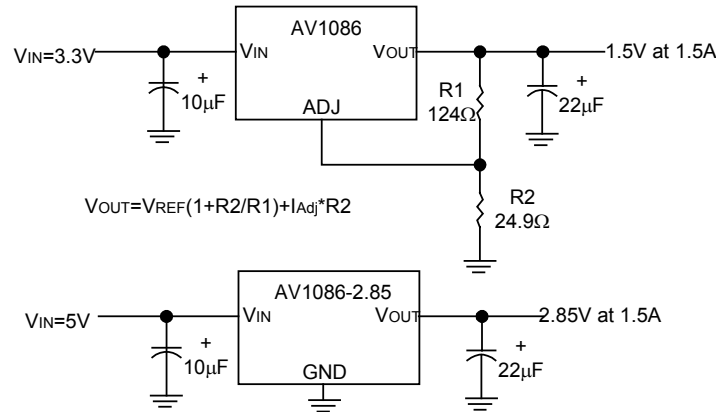

ABSOLUTE MAXIMUM RATINGS (Ta=25°C, unless otherwise specified)

PARAMETER	MIN	MAX	UNIT
V _{IN}		7.5	V
Operating Junction Temperature Range	0	125	°C
Storage Temperature Range	-65	150	°C
Lead Temperature (Soldering, 10 sec)		300	°C

ELECTRICAL CHARACTERISTICS (V_{IN}≤7V, T_J=25°C, unless otherwise specified.

The *denotes specifications which apply over the specified operating temperature range.)

PARAMETER	SYMBOL		TEST CONDITIONS	MIN	TYP	MAX	UNIT
Reference Voltage (note 3)	V _{REF}	*	1.5V ≤ (V _{IN} - V _{OUT}) ≤ 5.75V 10mA ≤ I _{OUT} ≤ 1A	1.225	1.25	1.275	V
Output Voltage		*	10mA ≤ I _{OUT} ≤ 1A				
		*	UZ1086-1.8V 3.3V ≤ V _{IN} ≤ 7V	1.764	1.80	1.836	V
		*	UZ1086-2.5 4V ≤ V _{IN} ≤ 7V	2.450	2.50	2.550	V
		*	UZ1086-2.85 4.35V ≤ V _{IN} ≤ 7V	2.793	2.85	2.907	V
		*	UZ1086-3.3 4.8V ≤ V _{IN} ≤ 7V	3.234	3.30	3.366	V
			UZ1086-5.0 6.5V ≤ V _{IN} ≤ 7V	4.900	5.00	5.100	V
Line Regulation (note 1,2)		*	(V _{OUT} +1.5V) ≤ V _{IN} ≤ 7V, I _{OUT} =10mA		0.005	0.2	%
Load Regulation (note 1,2)		*	V _{IN} - V _{OUT} = 2V, 10mA ≤ I _{OUT} ≤ 1A		0.05	0.5	%
Dropout Voltage		*	ΔV _{REF} = 1%, I _{OUT} = 1.5A		1.3	1.5	V
Current Limit		*	V _{IN} - V _{OUT} = 2V	1.6	2		A
Adjust Pin Current (note 3)	I _{Adj}	*			35	120	μA
Adjust Pin Current Change (note 3)		*	1.5V ≤ (V _{IN} - V _{OUT}) ≤ 5.75V, 10mA ≤ I _{OUT} ≤ 1A		0.2	5	μA
Minimum Load Current		*	1.5V ≤ (V _{IN} - V _{OUT}) ≤ 5.75V	10			mA
Quiescent Current		*	V _{IN} = V _{OUT} + 1.25V		4	13	mA

PARAMETER	SYMBOL	TEST CONDITIONS	MIN	TYP	MAX	UNIT
Ripple Rejection		f=120Hz, C _{OUT} =22 μ F, Tantalum V _{IN} - V _{OUT} =3V, I _{OUT} =1.5A	60	72		dB
Thermal Regulation		T _A =25°C, 30ms pulse		0.004	0.02	%/W
Temperature Stability		*		0.5		%
Long-Term Stability		T _A =125°C, 1000hrs		0.03	1	%
RMS Output Noise	V _{OUT}	T _A =25°C, 10Hz \leq f \leq 10kHz		0.003		%
Thermal Resistance Junction to Case (note 4)		SOT-223 TO-252, TO-263, TO-220		15 3		°C/W
Thermal Shutdown		Junction Temperature		155		°C
Thermal Shutdown Hysteresis				10		°C

Note:

1. See thermal regulation specifications for changes in output voltage due to heating effects. Load and line regulation are measured at a constant junction temperature by low duty cycle pulse testing.
2. Line and load regulation are guaranteed up to the maximum power dissipation. Power dissipation is determined by input/output differential and the output current. Guaranteed maximum output power will not be available over the full input/output voltage range.
3. AV1086 adjustable only.
4. With package soldered to 0.5 square inch copper area over backside ground plane or internal power plane, Thermal Resistance Junction to Ambient can vary from 30°C/W to more than 50°C/W. Other mounting techniques may provide better thermal resistance than 30°C/W.

TYPICAL PERFORMANCE CHARACTERISTICS

Figure 1. Dropout Voltage vs. Output Current

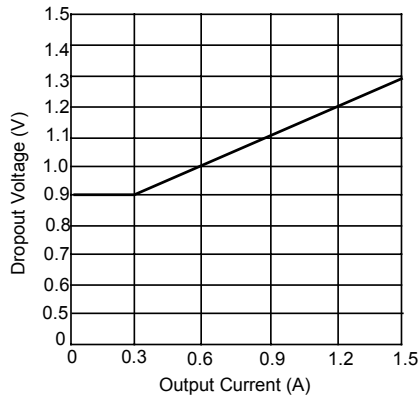

Figure 2. Load Regulation vs. Temperature

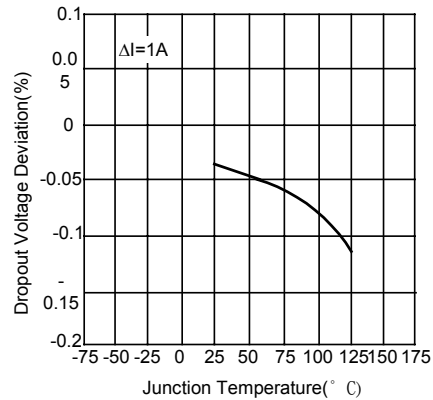

Figure 3. Reference Voltage vs. Temperature

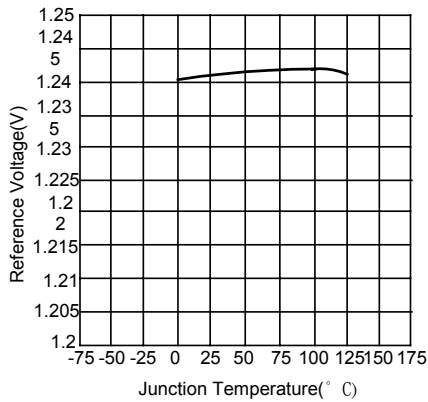

Figure 4. Output Voltage vs. Temperature

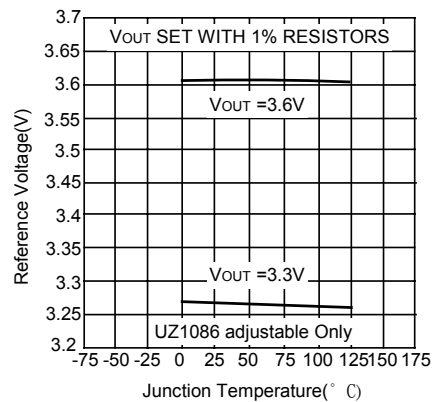

Figure 5. Minimum Load Current vs. Temperature

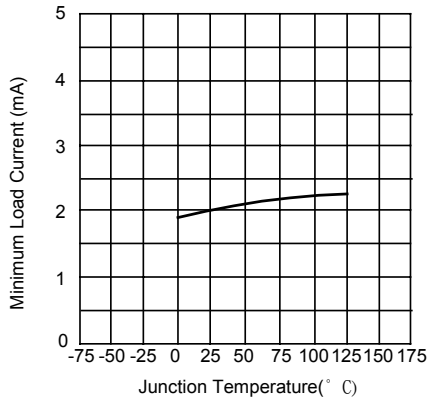

Figure 6. Adjust Pin Current vs. Temperature

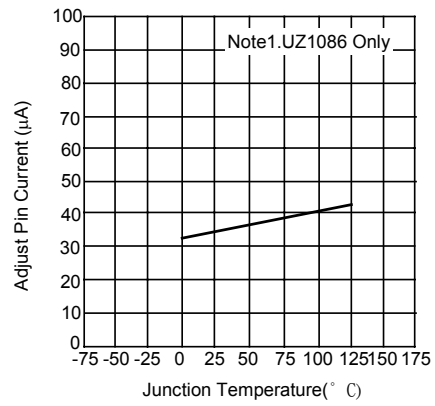

Figure 7. Short-Circuit Current vs. Temperature

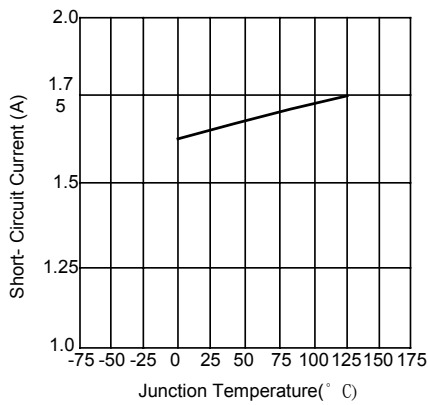

Figure 8. Ripple Rejection vs. Frequency

