

**GENERAL DESCRIPTION**

The AV1085 is a positive and low dropout three-terminal voltage regulator with 3A output current capability. This device is designed for use in low voltage applications that offers lower dropout voltage and faster transient response.

This device is fully protected against over current faults, over temperature operation, reversed input polarity, reversed lead insertion, transient voltage spike ...etc.

On-Chips trimming the reference voltage to 1% and features the low dropout of maximum 1.45 volts.

The AV1085 Series regulators are available in the popular industry standard TO-220 TO-263 and TO-252 packages.

**FEATURES**

- Very easy to use, it requires only two external resistors to set the output voltage
- Low dropout voltage: 1.3V typical at up to 3A
- Low ground current
- Fast transient response
- Current & thermal limiting
- Line regulation: 0.5% typical
- Load regulation: 0.5% typical
- TO-220, TO-263 and TO-252 packages

**APPLICATIONS**

- High current microprocessor supplies
- Low voltage logic supply
- Powering VGA & sound card
- Portable instrumentation
- Constant current regulator
- Post regulator for switching power supply

**TYPICAL APPLICATION**

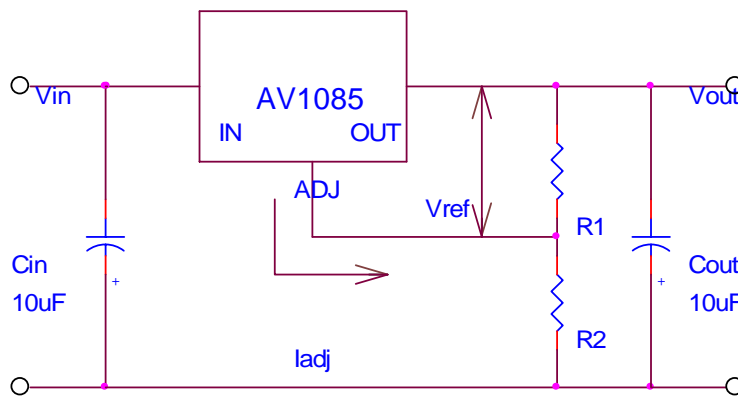

$$V_o = V_{ref} (1 + R_2/R_1) + I_{adj} \times R_2$$

1. Cin needed if device is far from filter capacitors.
2. Cout required for stability.

**- Basic Adjustable Regulator Circuit -**

## ABSOLUTE MAXIMUM RATINGS

|   |                    |  |               |
|---|--------------------|--|---------------|
| ● Maximum Supply Voltage                                | 7V                 | ● Operating Junction Temperature Range     | 0 to 125 °C   |
| ● Power Dissipation                                     | Internally Limited | ● Storage Temperature Range                | -40 to 150 °C |
| ● Thermal Resistance Junction to Case, $\theta_{JC}$    | 5 °C/W             | ● Lead Temperature (Soldering, 10 Seconds) | 260 °C        |
| ● Thermal Resistance Junction to Ambient, $\theta_{JA}$ |                    |  |               |
| TO-263  | 60 °C/W            |  |               |
| TO-252  | 70 °C/W            |  |               |
| TO-220  | 50 °C/W            |  |               |

## ELECTRICAL CHARACTERISTICS (Unless otherwise specified, $T_A = 25\text{ °C}$ .)

| Parameter              | Symbol         | Test Conditions  | Typical             | Limits                                       |
|------------------------|----------------|--|---------------------|--|
| Reference Voltage      | $V_{REF}$      | $V_{IN} = 5V, I_{OUT} = 10mA$  | 1.25V               | 1.23V <sub>Min</sub><br>1.27V <sub>Max</sub> |
| Dropout Voltage        | $V_D$          | $\Delta V_{REF} = 1\%, I_{OUT} = 3A$                                       | 1.3V                | 1.45V  |
| Line Regulation        | $REG_{(LINE)}$ | $(V_{OUT} + 1.5V) \leq V_{IN} \leq 7V, I_{OUT} = 10mA$                     | 0.5%                | 2%   |
| Load Regulation        | $REG_{(LOAD)}$ | $(V_{IN} - V_{OUT}) = 3V, 10mA \leq I_{OUT} \leq 3A$                       | 0.5%                | 2.5%   |
| Minimum Load Current   | $I_O$          | $1.5V \leq (V_{IN} - V_{OUT}) \leq 5.75V$                                  | 10mA                |  |
| Adjust Pin Current     | $I_{ADJ}$      |  | 55 $\mu$ A          | 100 $\mu$ A                                  |
| Current Limit          | $I_{CL}$       | $V_{IN} - V_{OUT} = 2V$  | 5.0A                | 4.0A (Min)                                   |
| RMS Output Noise       | $V_N$          |  | 0.003% of $V_{OUT}$ |  |
| Ripple Rejection Ratio | $R_A$          | $f = 120Hz, C_{ADJ} = 22\mu F$ for ADJ pin,<br>$V_{IN} = 5V, I_{OUT} = 3A$ | 72dB                | 60dB (Min)                                   |

## DEVICE SELECTION GUIDE

| Device  | AV1085D | AV1085S         | AV1085S3        | AV1085T |
|---------|---------|-----------------|-----------------|---------|
| Package | TO-252  | TO-263 (2-Lead) | TO-263 (3-Lead) | TO-220  |
| Marking | AV1085D | AV1085S         | AV1085S3        | AV1085T |

**PIN CONFIGURATIONS**

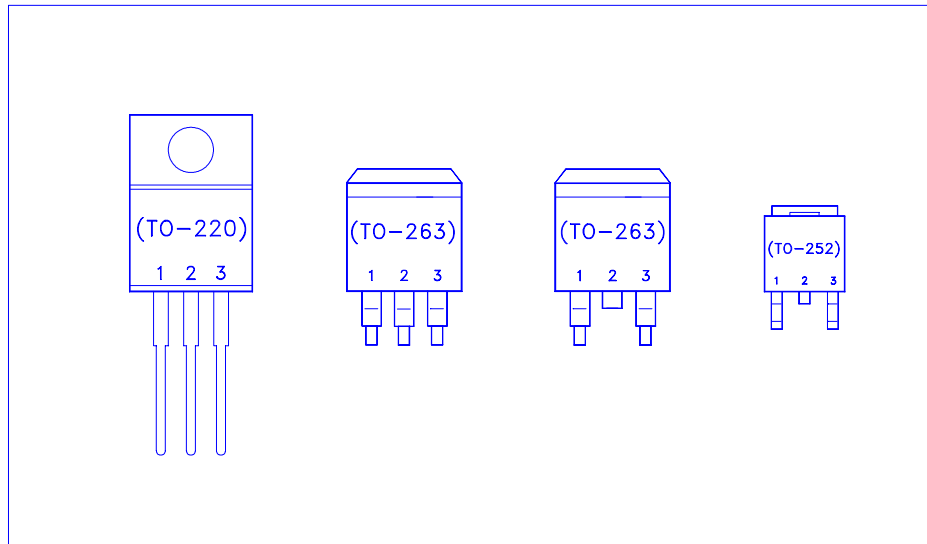

| Pin # | Function |
|-------|----------|
| 1     | Adjust   |
| 2     | Output   |
| 3     | Input    |

**Note: TAB is Output Pin**

TO-263 (D<sup>2</sup>PAK) MECHANICAL DATA

| Dimension | mm     |      |       | Dimension | mm   |      |      |
|-----------|--------|------|-------|-----------|------|------|------|
|           | Min.   | Typ. | Max.  |           | Min. | Typ. | Max. |
| A         | 14.5   | 15   | 15.8  | H         | 1.0  | 1.5  | 1.8  |
| B         | 4.2    |      | 4.7   | I         | 9.8  |      | 10.3 |
| C         | 1.20   |      | 1.35  | J         |      | 6.5  |      |
| D         |        | 2.8  |       | K         |      | 1.5  |      |
| E         | 0.3    | 0.4  | 0.5   | L         | 0.7  |      | 1.4  |
| F         | -0.102 |      | 0.203 | M         | 4.83 | 5.08 | 5.33 |
| G         | 8.5    | 9    | 9.5   | N         |      |      |      |

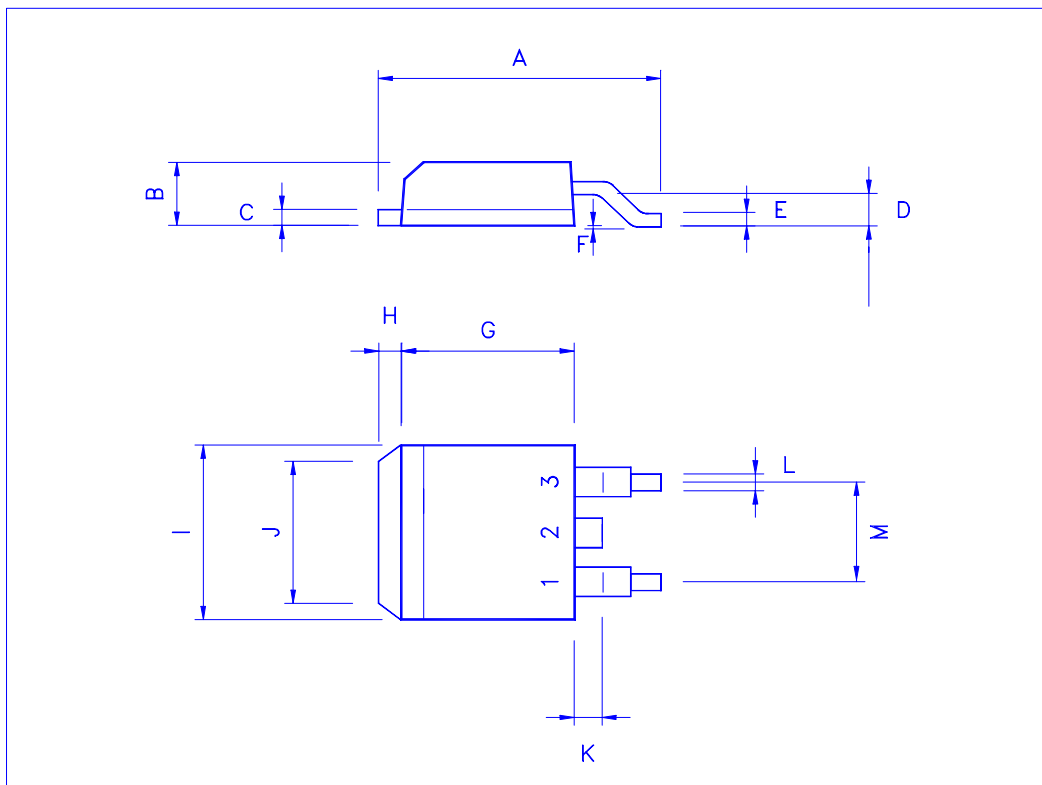

TO-263 (D<sup>2</sup>PAK) MECHANICAL DATA

| Dimension | mm     |      |       | Dimension | mm   |      |      |
|-----------|--------|------|-------|-----------|------|------|------|
|           | Min.   | Typ. | Max.  |           | Min. | Typ. | Max. |
| A         | 14.5   | 15   | 15.8  | H         | 1.0  | 1.5  | 1.8  |
| B         | 4.2    |      | 4.7   | I         | 9.8  |      | 10.3 |
| C         | 1.20   |      | 1.35  | J         |      | 6.5  |      |
| D         |        | 2.8  |       | K         |      | 1.5  |      |
| E         | 0.3    | 0.4  | 0.5   | L         | 0.7  |      | 1.4  |
| F         | -0.102 |      | 0.203 | M         | 4.83 | 5.08 | 5.33 |
| G         | 8.5    | 9    | 9.5   | N         |      |      |      |

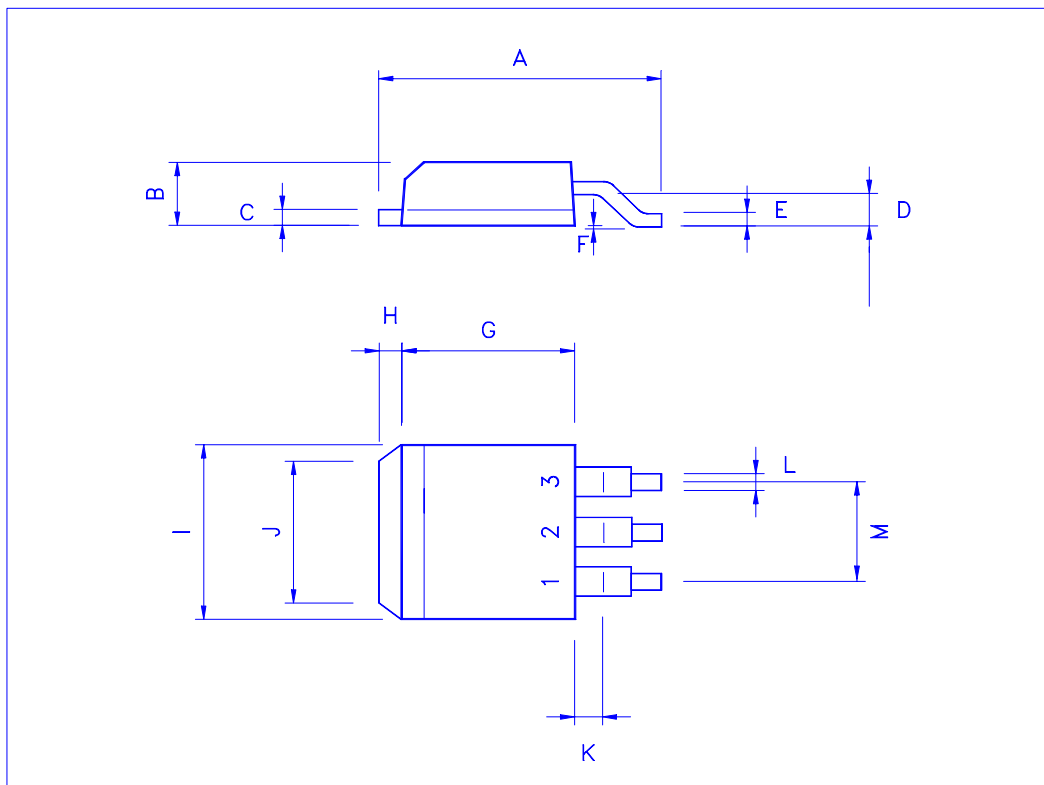

TO-220 (3-Lead) MECHANICAL DATA

| Dimension | mm   |       |       | Dimension | mm   |      |      |
|-----------|------|-------|-------|-----------|------|------|------|
|           | Min. | Typ.  | Max.  |           | Min. | Typ. | Max. |
| A         | 9.78 | 10.16 | 10.54 | H         | 2.4  | 2.54 | 2.68 |
| B         | 2.61 | 2.74  | 2.87  | I         | 1.19 | 1.27 | 1.35 |
| C         |      | 20    |       | J         | 4.4  | 4.6  | 4.8  |
| D         | 28.5 | 28.9  | 29.3  | K         | 1.14 | 1.27 | 1.4  |
| E         | 14.6 | 15.0  | 15.4  | L         | 2.3  | 2.6  | 2.9  |
| F         | 8.4  | 8.8   | 9.2   | M         | 0.26 | 0.46 | 0.66 |
| G         | 0.72 | 0.8   | 0.88  | N         |      | 7°   |      |

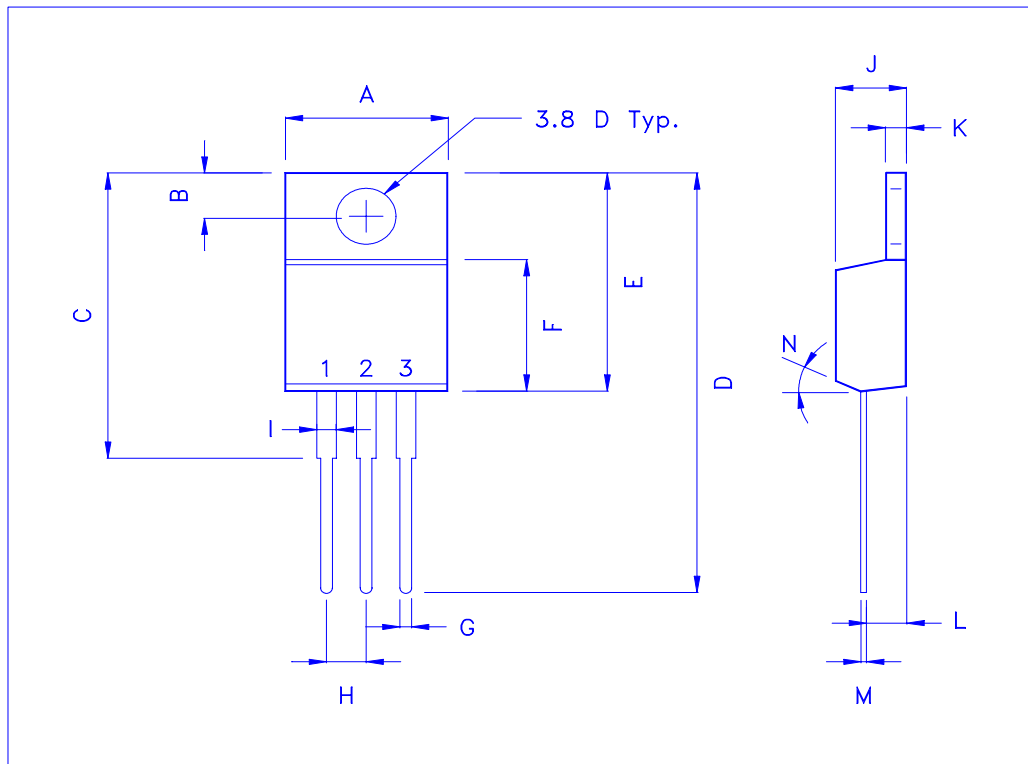

TO-252 (DPAK) MECHANICAL DATA

| Dimension | mm   |      |      | Dimension | mm   |      |      |
|-----------|------|------|------|-----------|------|------|------|
|           | Min. | Typ. | Max. |           | Min. | Typ. | Max. |
| A         | 9.35 |      | 10.1 | H         |      | 0.8  |      |
| B         | 2.2  |      | 2.4  | I         | 6.4  |      | 6.6  |
| C         | 0.48 |      | 0.6  | J         | 5.2  |      | 5.4  |
| D         | 0.89 |      | 1.5  | K         | 0.6  |      | 1    |
| E         | 0.45 |      | 0.6  | L         | 0.64 |      | 0.9  |
| F         | 0.03 |      | 0.23 | M         | 4.4  |      | 4.6  |
| G         | 6    |      | 6.2  | N         |      |      |      |

