

Features

- Capability of Single-wire Operation
- Hardware Fault Recognition
- Inputs with High Common-mode and Differential-mode Interference Rejection Above 100 V_{pp} due to External Filters at the Receiver Input
- Immunity Against Electromagnetic Interference
- Immunity Against Ground-voltage Offsets < 6 V
- Ruggedized Against ESD by MIL-STD-883C, Method 3015

Benefits

Systems which employ this device have the following benefits compared to solutions using discrete components:

- High Reliability

Applications

- Especially Suited for Truck and Van Applications
- Interface Between Truck and Trailer
- Interface Between Dashboard and Engine

Description

The CAN driver IC B10011S is a low-speed, high-level interface for 24 V (27 V) operation with transmission levels according to ISO WD 11992-1 (point-to-point interface between trucks and trailers). It is developed for signal levels of 8/16 V and a speed of up to 250 kbits/s.

This device allows transmission, that is insensitive to electromagnetic interference. Such interferences may especially occur in truck applications where (due to the length of the wires) high common-mode voltages (e.g., 50 V) can be coupled into the lines.

This device contains a fault recognition circuit that detects faults on one of the two wires, which are normally used for transmission. If a fault occurs the operation can be switched from double-wire to single-wire mode thus, allowing proper operation even if one wire is broken, has a short-cut or a high series resistance.

Figure 1. Block Diagram

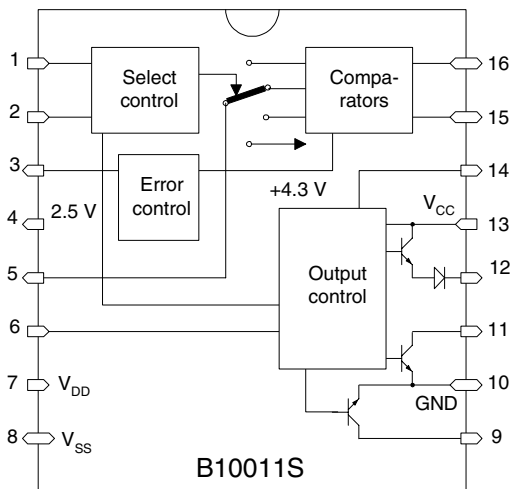

CAN Transceiver IC

B10011S

Rev. 4749B-AUTO-09/04



Pin Configuration

Figure 2. Pinning SO16

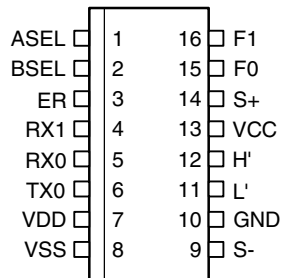

Pin Description

16-lead SOIC (SO16), Small Outline Gull - Wing

| Pin | Symbol | Function |
|-----|--------|----------------------------------|
| 1 | ASEL | Select control input |
| 2 | BSEL | Select control input |
| 3 | ER | Error signal output |
| 4 | RX1 | Reference voltage 2.5 V |
| 5 | RX0 | Receiver output |
| 6 | TX0 | Transmitter input |
| 7 | VDD | Controller supply voltage 5 V |
| 8 | VSS | Controller supply voltage 0 V |
| 9 | S- | Collector of internal NPN switch |
| 10 | GND | Vehicle ground 0 V |
| 11 | L' | Data out driver |
| 12 | H' | Data out driver |
| 13 | VCC | Vehicle power supply 24 V |
| 14 | S+ | Control output for external PNP |
| 15 | F0 | Receiver input |
| 16 | F1 | Receiver input |

Absolute Maximum Ratings

Stresses beyond those listed under “Absolute Maximum Ratings” may cause permanent damage to the device. This is a stress rating only and functional operation of the device at these or any other conditions beyond those indicated in the operational sections of this specification is not implied. Exposure to absolute maximum rating conditions for extended periods may affect device reliability.

| Parameters | Symbol | Value | Unit |
|--|-----------|------------------|------|
| Supply voltage | V_{CC} | -0.5 to +36 | V |
| Controller supply voltage | V_{DD} | -0.5 to +5.5 | V |
| Input voltage at any input | V_{in} | -0.5 to V_{DD} | V |
| Junction temperature | T_j | 150 | °C |
| Storage temperature range | T_{stg} | -55 to +150 | °C |
| Soldering temperature (for 10 s maximum) | T_{sld} | 260 | °C |

Operating Conditions

| Parameters | Symbol | Value | Unit |
|----------------------------|--------------------|---------------|------|
| Supply voltage car battery | V_{CC} | 7 to 32 | V |
| Controller supply voltage | V_{DD} | 4.75 to 5.25 | V |
| Control input voltage | A_{sel}, B_{sel} | 0 to V_{DD} | V |
| Input voltage | T_{x0} | 0 to V_{DD} | V |
| Operating temperature | T_{amb} | -40 to +105 | °C |

Operating Modes

0 = 0 V, 1 = 5 V

| A_{sel} | B_{sel} | R_{x0} | Mode |
|-----------|-----------|----------|---|
| 0 | 0 | 3.8 V | H, L drivers disabled, L load disabled, S-, S+ disabled station not in operation, but consuming current |
| 1 | 0 | From H | Single-wire H, L driver, L load, S-, S+ disabled |
| 0 | 1 | From L | Single-wire L, H driver disabled |
| 1 | 1 | From L-H | Two-wire operation, normal mode |

ER (error signal) is low when normal operation is disturbed by line faults (interruption, short to ground or to V_{CC} , H to L short disturbance by high voltage transients). After a waiting period due to transient delays, the controller is asked to test if single-wire operation is possible by changing the A_{sel} and B_{sel} state.

A_{sel} and B_{sel} have an internal pull-up resistor. Therefore, the no-connect state is 1, but connection to V_{DD} is recommended when not in use.

Pulse Diagram

The pulse diagram for two connected, identical stations is shown below. The resistor levels have to be kept constant when additional stations are connected.

Figure 3. Pulse Diagram

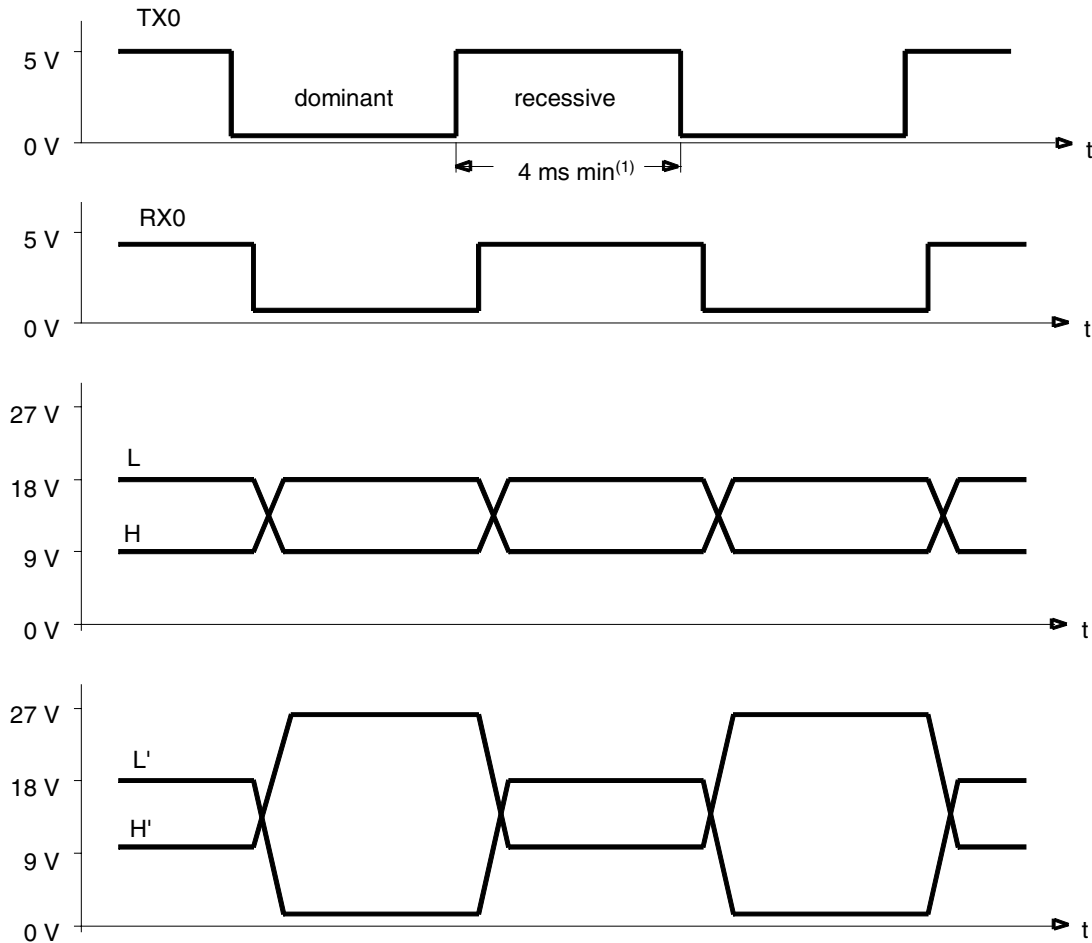

⁽¹⁾ Filter has to be changed if short distances are to be allowed

Electrical Characteristics

Test condition: Test circuit (see Figure 4 on page 6), 0 = 0 V, 1 = 5 V

V_{CC} = 27 V, V_{DD} = 5 V, V_{SS} = 0 V, T_{amb} = -40°C to +105°C, unless otherwise specified.

| Parameters | Test Conditions | Symbol | Min. | Typ. | Max. | Unit |
|----------------|---|---|------|------|------|------|
| Supply current | T _{x0} = 0, A _{sel} = 1, B _{sel} = 1 | I _{CC} | | | 15 | mA |
| | T _{x0} = 0, A _{sel} = 0, B _{sel} = 0 | I _{DD} | | | 22 | mA |
| | T _{x0} = 1, A _{sel} = 1, B _{sel} = 1 | I _{CC} | | | 26 | mA |
| | T _{x0} = 1, A _{sel} = 1, B _{sel} = 1 | I _{DD} | | | 16 | mA |
| Input current | T _{x0} = 1, A _{sel} = 1, B _{sel} = 1 | I(T _{x0}) | | | 650 | μA |
| | T _{x0} = 1, A _{sel} = 1, B _{sel} = 1 | I(A _{sel} , B _{sel}) | | | 150 | μA |
| Output voltage | T _{x0} = 0, A _{sel} = 1, B _{sel} = 0 V _{IL} (F ₀) = 1.9 V, V _{IH} (F ₁) = 2.7 V | R _{x0} | | | 1.0 | V |
| | T _{x0} = 1, A _{sel} = 1, B _{sel} = 1 V _{IL} (F ₁) = 1.9 V, V _{IH} (F ₀) = 2.7 V | R _{x0} | 3.8 | | | V |
| | T _{x0} = 0, A _{sel} = 1, B _{sel} = 1 | U(H') | 24.5 | | | V |
| | T _{x0} = 1, A _{sel} = 1, B _{sel} = 1 | U(H') | | | 1.0 | V |
| | T _{x0} = 1, A _{sel} = 1, B _{sel} = 1 | U(L') | 26 | | | V |
| | T _{x0} = 0, A _{sel} = 1, B _{sel} = 1 | U(L') | | | 1.0 | V |
| | No fault | ER | 4.7 | | | V |
| | Fault on line | ER | | | 100 | mV |

V_{CC} = 7 V, V_{DD} = 4.75 V, V_{SS} = 0 V, T_{amb} = 25°C, unless otherwise specified.

| Parameters | Test Conditions | Symbol | Min. | Typ. | Max. | Unit |
|----------------|--|-----------------|------|------|------|------|
| Output voltage | T _{x0} = 0, A _{sel} = 1, B _{sel} = 1 | U(H') | 4.5 | | | V |
| | T _{x0} = 1, A _{sel} = 1, B _{sel} = 1 | U(H') | | | 100 | mV |
| | T _{x0} = 1, A _{sel} = 1, B _{sel} = 0 | U(L') | 6.5 | | | V |
| | T _{x0} = 0, A _{sel} = 1, B _{sel} = 1 | U(L') | | | 1.0 | V |
| | T _{x0} = 1, A _{sel} = 1, B _{sel} = 0 V _{IL} (F ₁) = 1.0 V, V _{IH} (F ₀) = 1.15 V | R _{x0} | 3.3 | | | V |
| | T _{x0} = 0, A _{sel} = 1, B _{sel} = 0 V _{IL} (F ₀) = 1.0 V, V _{IH} (F ₁) = 1.15 V | R _{x0} | | | 1.0 | V |

V_{CC} = 32 V, V_{DD} = 5.25 V, V_{SS} = 0 V, T_{amb} = 25°C, unless otherwise specified.

| Parameters | Test Conditions | Symbol | Min. | Typ. | Max. | Unit |
|----------------|---|-----------------|------|------|------|------|
| Output voltage | T _{x0} = 0, A _{sel} = 1, B _{sel} = 1 | U(H') | 29 | | | V |
| | T _{x0} = 1, A _{sel} = 1, B _{sel} = 1 | U(H') | | | 500 | mV |
| | T _{x0} = 1, A _{sel} = 1, B _{sel} = 0 | U(L') | 31.5 | | | V |
| | T _{x0} = 0, A _{sel} = 1, B _{sel} = 1 | U(L') | | | 1.0 | V |
| | T _{x0} = 1, A _{sel} = 1, B _{sel} = 0 V _{IL} (F ₁) = 1.6 V, V _{IH} (F ₀) = 2.7 V | R _{x0} | 4.0 | | | V |
| | T _{x0} = 0, A _{sel} = 1, B _{sel} = 0 V _{IL} (F ₀) = 1.6 V, V _{IH} (F ₁) = 2.7 V | R _{x0} | | | 1.0 | V |

Figure 4. Test Circuit

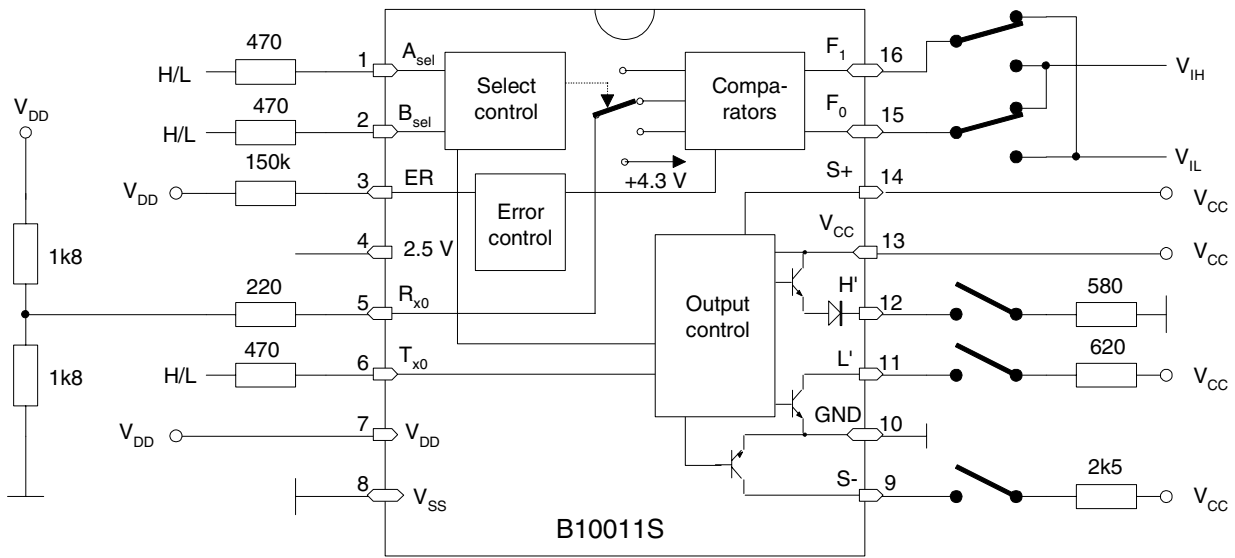
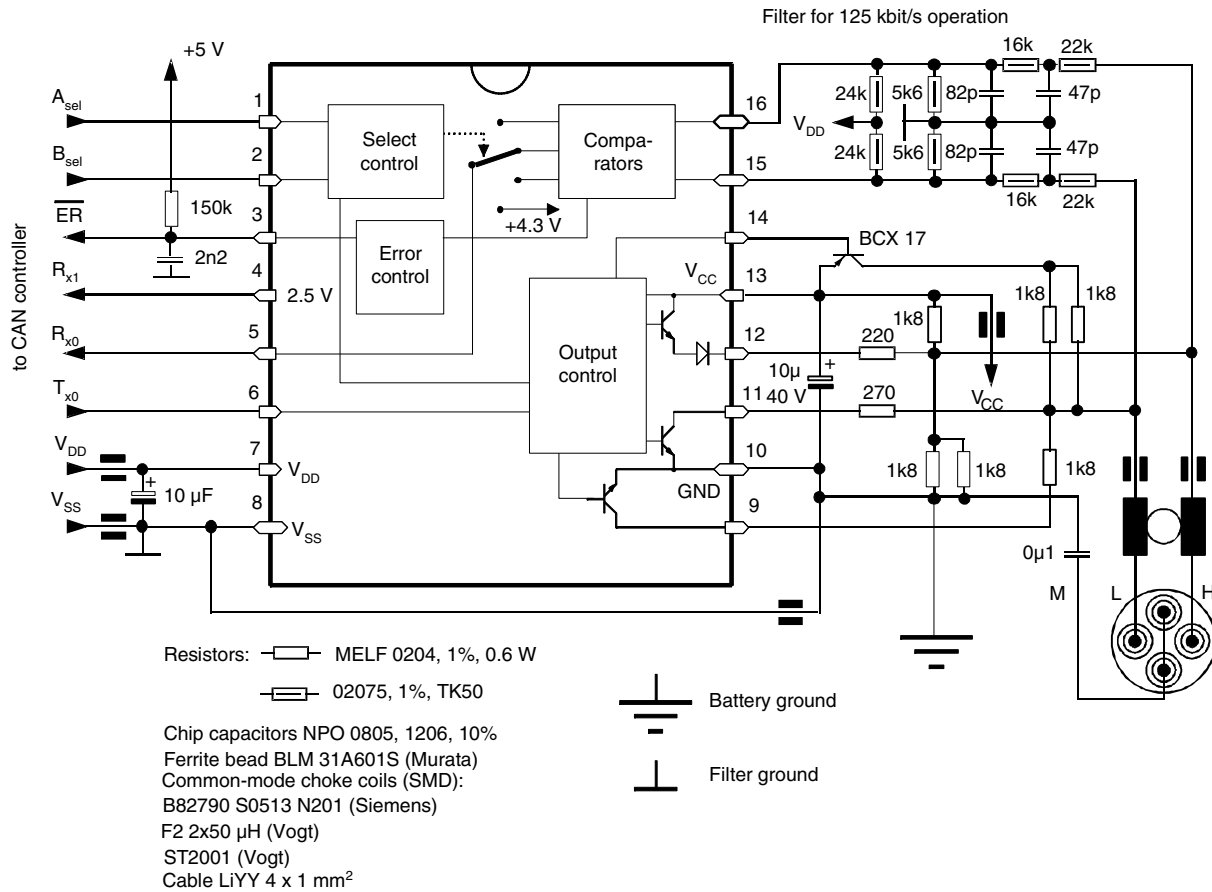
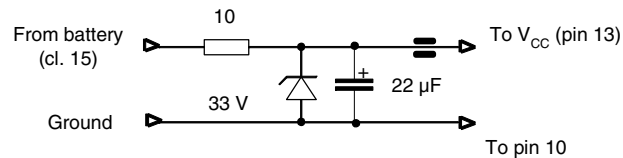

Figure 5. Application Circuit



The implementation of a power filter and overvoltage clamp as follows is highly recommended:

Figure 6. Implementation of a Power Filter and Over Clamps



Application Hints

As an interface between CAN controllers and a two-wire data bus system for serial data interchange, this device is adapted to a special high-level, low-speed transmission system, which is useful in harsh environments. High immunity against ground offset and interference voltages on the bus have been the design goals for this device, rather than low power consumption or a minimum of external components. An error detection scheme is implemented in the receiver part to give quick information to the controller in case of faults occurring on the bus. Thus, the controller is able to start a search cycle in order to look for the possibility of single-wire operation or to disable the station from the bus.

An automatic error-signal end is not feasible because parts of the system are disabled during single-wire operation. Therefore, the controller has to carry out short tests by switching to the two-wire state and checking, whether the error signal is still present or not. Errors due to dirty contacts, shorts between high and low line, or interruptions may not be recognized at all, because this device does not contain a complete fault computer.

Two control inputs A_{sel} and B_{sel} enable four operation modes (see Table "Operating Modes" on page 3'). Depending on the nature of the error, the error signal ER is internally generated partly in the recessive or partly in the dominant transmission state. In order to avoid watching the error bits bitwise, an open-collector output driver (with a 1-k Ω series resistor) discharges a storage capacitor, which is charged by a time constant, long enough to hold the 0 state for, e.g., 200 μ s, thus, giving the controller enough time to recognize this status during idle times. Only the charging resistor may be changed and not the 2.2-nF capacitor. In order to perform a faster error-end test, the charging resistor may be shorted by an NPN emitter follower or by a tristate output high for approximately 1 to 2 μ s.

The pinout of the device shows a controller side (pins 1 to 8) and a bus side (pins 9 to 16). The application circuit utilizes an input filter section which is necessary for every station and a bias section which is needed in two master stations only. Additional slave stations only contain the driving resistors at pins 11 and 12 (270 Ω and 220 Ω), the choke coil, and capacitor between pins 13 and 10.

A power filter and overvoltage clamp is highly recommended in order to avoid transmission errors due to spikes on the 24-V battery voltage.

The input filter is designed as an 2-RC filter for 125 kbit/s and may be changed to 250 kbit/s. Its good pulse response and good suppression of high frequencies should not be weakened by omitting one of the capacitors.

All the logical and sensing functions in the device are powered by $V_{DD} = 5\text{ V}$. Therefore, the filter section also acts as a level shifter to the input comparator range (approximately 1 to 3.3 V). The diagram (see Figure 7) shows how the battery voltage, V_{CC} , influences the comparator input voltages, F_0 and F_1 , in relation to the internal reference voltage, V_{ref} , in the recessive state. The lower V_{CC} , the lower the bus level. Taking this into account the comparator input levels are $F_1 - V_{ref}$ for single-wire H respectively $F_1 - F_0$ for two-wire operation. The comparator's offset voltage is $\leq 10\text{ mV}$. Matching the filter biasing to the internal reference is essentially for safe operation even at low battery voltages during motor start.

The level investigations and tests described in the following description have been carried out within the temperature range of -40°C to $+105^\circ\text{C}$ with two B10011S on a bus line, one of them always in the recessive state (see Figure 8 on page 9).

In case of line shorts to V_{CC} or to ground or in case of H to L shorts, all participants on the bus are intended to switch to single-wire operation and to disable their drivers not in use.

The dynamic behavior of the circuit depends on the line capacitances to ground. Approximately 200 pF/m and a maximum of 6 nF have to be taken into account. The transition from the dominant to the recessive state enables the bias network to recharge the line through a driving resistor of approximately $300\ \Omega$. The transition from the recessive to the dominant state is approximately twice as fast. This is probably the source of emitted radiation having no capacitance on the line. The choke coil enables the suppression of this radiation in the frequency range above 5 MHz to 7 MHz . Care should be taken not to feed noise from V_{DD} or V_{CC} to the line. Therefore, they should be properly blocked by low-inductance capacitors.

Data loss by externally induced interference is avoided by careful PCB layout and EMC design for this circuit as well as by providing appropriate overvoltage protection. It is very essential to separate battery ground and filter ground as indicated in the application circuit (see Figure 5 on page 6). Especially important is that the filter ground must be connected to pin 8 by a short connection not subject to disturbing currents from external sources. The ground wire of the "starquad" cable may introduce such currents and should be connected to battery ground via a $0.1\text{-}\mu\text{F}$ capacitor in a way as short as possible, perhaps to the metal housing.

In order to avoid thermal problems, the voltage divider and driving resistors should be kept away from the IC. Otherwise they would heat up the environment of the small IC and might reduce its life expectancy.

Figure 7. Comparator Thresholds

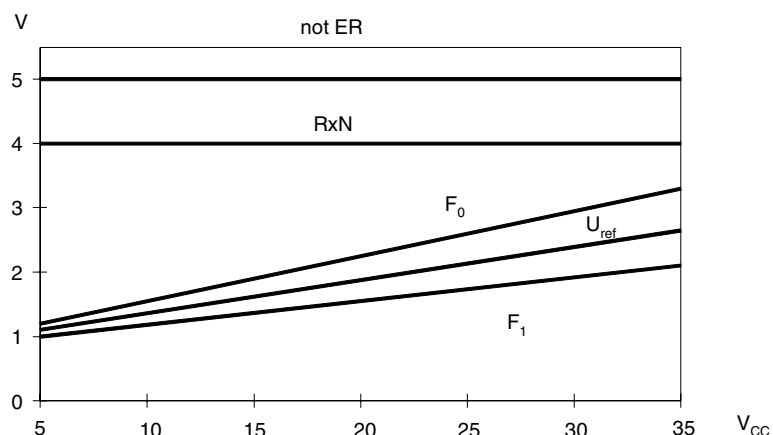
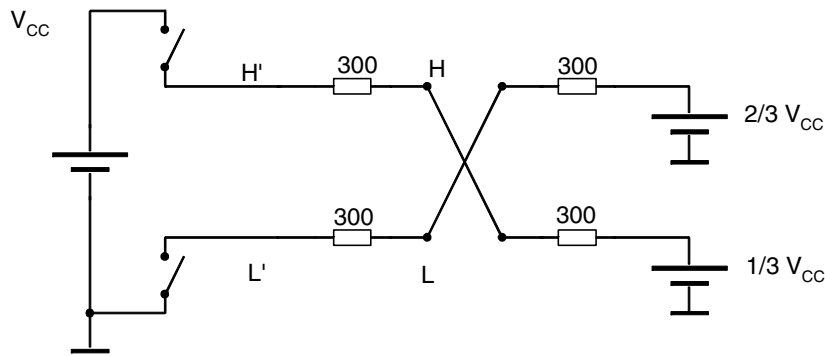
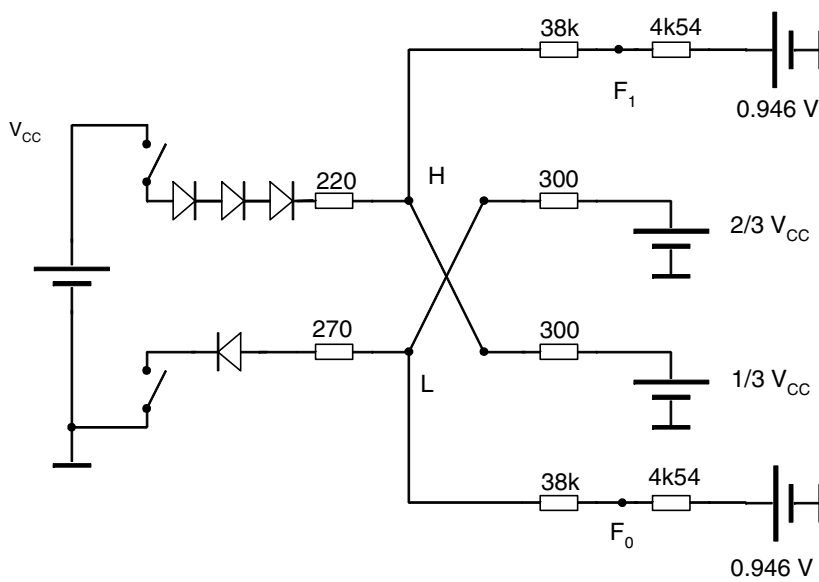

Figure 8. Test Circuit Equivalents



Ideal test circuit equivalent

Switches are closed in the dominant state



Real test circuit equivalent

Switches are closed in the dominant state

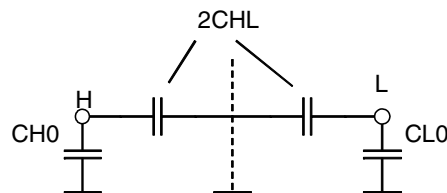

Capacitance H: CHgnd = CH0 + 2 CHL <= 200 pF/m
 Capacitance L: CLgnd = CL0 + 2 CHL <= 200 pF/m

Ordering Information

| Part Number | Package |
|---------------|--------------------------------------|
| B10011S-MFP | SO16 in tubes |
| B10011S-MFPG1 | SO16, tape and reel, 1000 units/reel |

Package Information

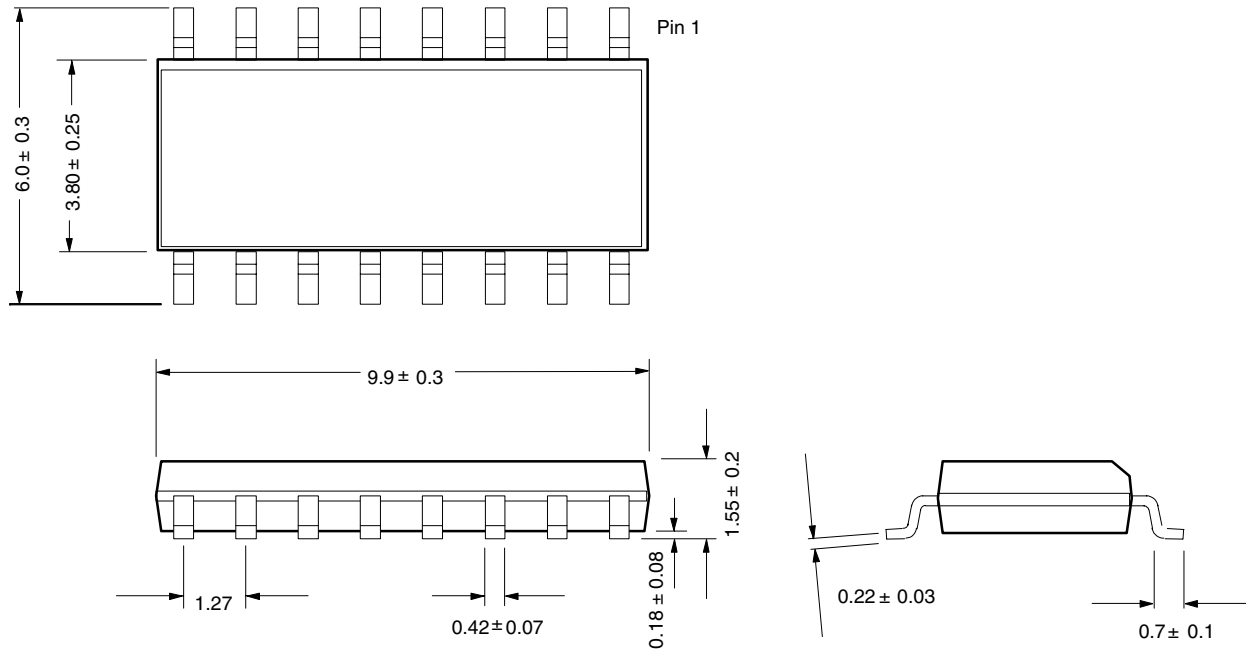

Revision History

Please note that the following page numbers referred to in this section refer to the specific revision mentioned, not to this document.

**Changes from Rev.
4749A - 10/03 to Rev.
4749B - 09/04**

1. Figure 2 "Pinning SO16" on page 2 changed.



Atmel Corporation

2325 Orchard Parkway
San Jose, CA 95131, USA
Tel: 1(408) 441-0311
Fax: 1(408) 487-2600

Regional Headquarters

Europe

Atmel Sarl
Route des Arsenalux 41
Case Postale 80
CH-1705 Fribourg
Switzerland
Tel: (41) 26-426-5555
Fax: (41) 26-426-5500

Asia

Room 1219
Chinachem Golden Plaza
77 Mody Road Tsimshatsui
East Kowloon
Hong Kong
Tel: (852) 2721-9778
Fax: (852) 2722-1369

Japan

9F, Tonetsu Shinkawa Bldg.
1-24-8 Shinkawa
Chuo-ku, Tokyo 104-0033
Japan
Tel: (81) 3-3523-3551
Fax: (81) 3-3523-7581

Atmel Operations

Memory

2325 Orchard Parkway
San Jose, CA 95131, USA
Tel: 1(408) 441-0311
Fax: 1(408) 436-4314

Microcontrollers

2325 Orchard Parkway
San Jose, CA 95131, USA
Tel: 1(408) 441-0311
Fax: 1(408) 436-4314

La Chantrerie
BP 70602
44306 Nantes Cedex 3, France
Tel: (33) 2-40-18-18-18
Fax: (33) 2-40-18-19-60

ASIC/ASSP/Smart Cards

Zone Industrielle
13106 Rousset Cedex, France
Tel: (33) 4-42-53-60-00
Fax: (33) 4-42-53-60-01

1150 East Cheyenne Mtn. Blvd.
Colorado Springs, CO 80906, USA
Tel: 1(719) 576-3300
Fax: 1(719) 540-1759

Scottish Enterprise Technology Park
Maxwell Building
East Kilbride G75 0QR, Scotland
Tel: (44) 1355-803-000
Fax: (44) 1355-242-743

RF/Automotive

Theresienstrasse 2
Postfach 3535
74025 Heilbronn, Germany
Tel: (49) 71-31-67-0
Fax: (49) 71-31-67-2340

1150 East Cheyenne Mtn. Blvd.
Colorado Springs, CO 80906, USA
Tel: 1(719) 576-3300
Fax: 1(719) 540-1759

Biometrics/Imaging/Hi-Rel MPU/ High Speed Converters/RF Datacom

Avenue de Rochepleine
BP 123
38521 Saint-Egreve Cedex, France
Tel: (33) 4-76-58-30-00
Fax: (33) 4-76-58-34-80

Literature Requests

www.atmel.com/literature

Disclaimer: Atmel Corporation makes no warranty for the use of its products, other than those expressly contained in the Company's standard warranty which is detailed in Atmel's Terms and Conditions located on the Company's web site. The Company assumes no responsibility for any errors which may appear in this document, reserves the right to change devices or specifications detailed herein at any time without notice, and does not make any commitment to update the information contained herein. No licenses to patents or other intellectual property of Atmel are granted by the Company in connection with the sale of Atmel products, expressly or by implication. Atmel's products are not authorized for use as critical components in life support devices or systems.

© Atmel Corporation 2004. All rights reserved.

Atmel® and combinations thereof are the registered trademarks of Atmel Corporation or its subsidiaries.

Other terms and product names may be the trademarks of others.



Printed on recycled paper.

4749B-AUTO-09/04