

# MODEL NUMBER 100C0347

## Transfer Switch

### FEATURES

- DC-400 MHz
- 0.4 dB Insertion Loss
- 20 Watt CW
- BNC, TNC or SMA Connectors

### XFER

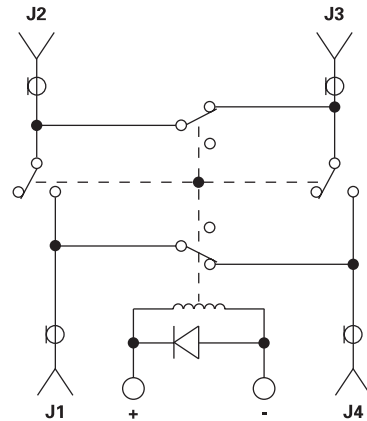
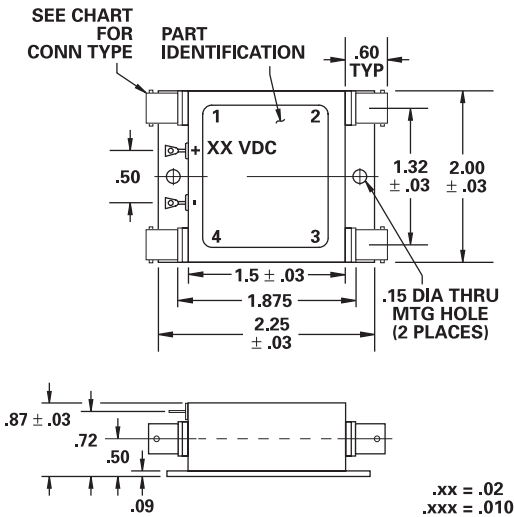

### GUARANTEED PERFORMANCE

Parameter	Min	Typ	Max	Units	Conditions
Operating Frequency	DC		400	MHz	
DC Voltage					See Table
Insertion Loss		0.3	0.5	dB	
Isolation	55	62		dB	
VSWR		1.2/1	1.4/1		
Impedance		50		OHMS	
Switching Speed			3	mSEC	
RF Power			20	W	CW
Operating Temperature	-55	+25	+85	°C	TA

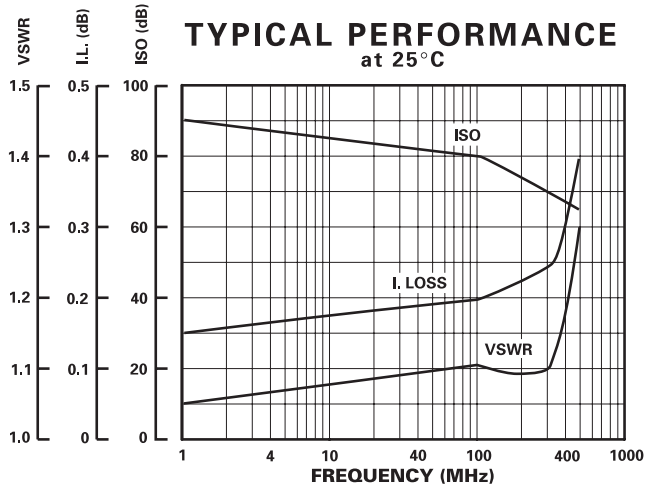

CONNECTOR TYPE
- BNC
- SMA
- TNC

CONTROL VOLTAGE TABLE	
Voltage	Current - Typical
6	240 mA per throw
12	125 mA per throw
18	85 mA per throw
26	70 mA per throw

PART NO. EXAMPLE - SEE TABLE  
**100C0347 - BNC - 12**  
 Basic Part Number      Coil Voltage  
                                          Connector Type



DAICO Industries

310.507.3242 • FAX 310.507.5701 • www.daico.com