

Am9517A/8237A*

Multimode DMA Controller

FINAL

DISTINCTIVE CHARACTERISTICS

- Four independent DMA channels, each with separate registers for Mode Control, Current Address, Base Address, Current Word Count and Base Word Count
- Transfer modes: Block, Demand, Single Word, Cascade
- Independent Autoinitialization of all channels
- Memory-to-memory transfers
- Memory block initialization
- Address increment or decrement
- Master system disable
- Enable/disable control of individual DMA requests
- Directly expandable to any number of channels
- End of Process input for terminating transfers
- Software DMA requests
- Independent polarity control for DREQ and DACK signals
- Compressed timing option speeds transfers—up to 2.5M bytes/second
- +5 volt power supply
- N-channel silicon gate MOS technology
- 40-pin Hermetic DIP package, 44-pin PLCC package
- 9517A-5 5 MHz version for higher speed CPU compatibility

GENERAL DESCRIPTION

The Am9517A/8237A Multimode Direct Memory Access (DMA) Controller is a peripheral interface circuit for micro-processor systems. It is designed to improve system performance by allowing external devices to directly transfer information to or from the system memory. Memory-to-memory transfer capability is also provided. The Am9517A/8237A offers a wide variety of programmable control features to enhance data throughput and system optimization and to allow dynamic reconfiguration under program control.

The Am9517A/8237A is designed to be used in conjunction with an external 8-bit address register such as the

Am74LS373. It contains four independent channels and may be expanded to any number of channels by cascading additional controller chips.

The three basic transfer modes allow programmability of the types of DMA service by the user. Each channel can be individually programmed to Autoinitialize to its original condition following an End of Process (EOP).

Each channel has a full 64K address and word count capability. An external EOP signal can terminate a DMA or memory-to-memory transfer. This is useful for block search or compare operations using external comparators or for intelligent peripherals to abort erroneous services.

BLOCK DIAGRAM

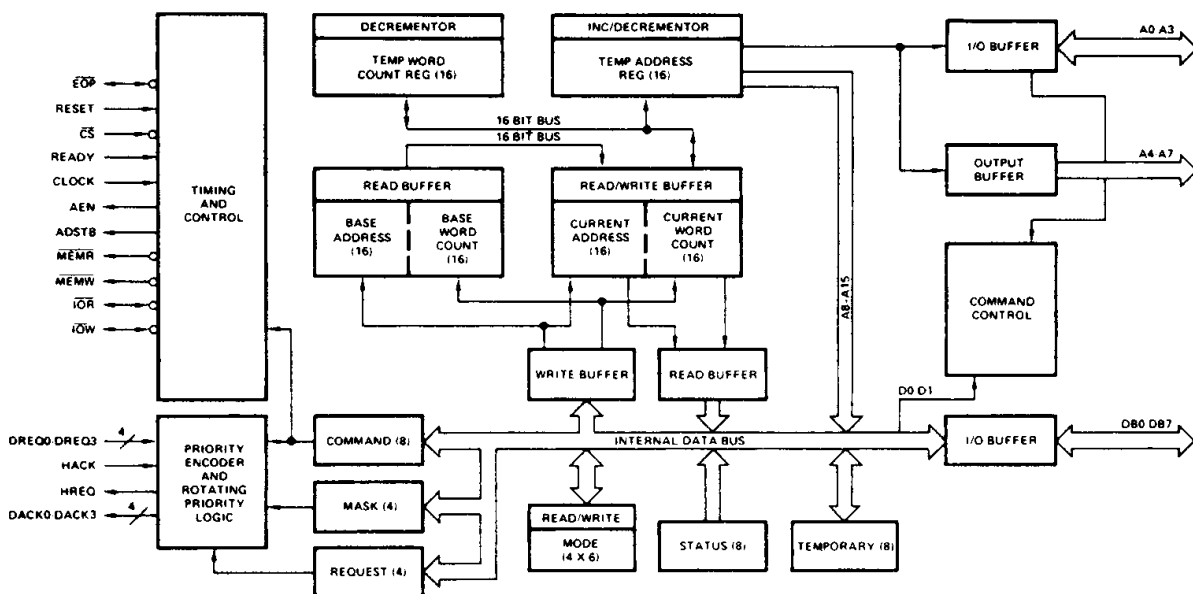

BD003250

*The 8237A is an AMD-invented device more commonly referred to as the Am9517A.

Publication # 03040
Rev. D
Amendment /0
Issue Date: August 1989

Am9517A/8237A

1-227

1

CONNECTION DIAGRAMS Top View

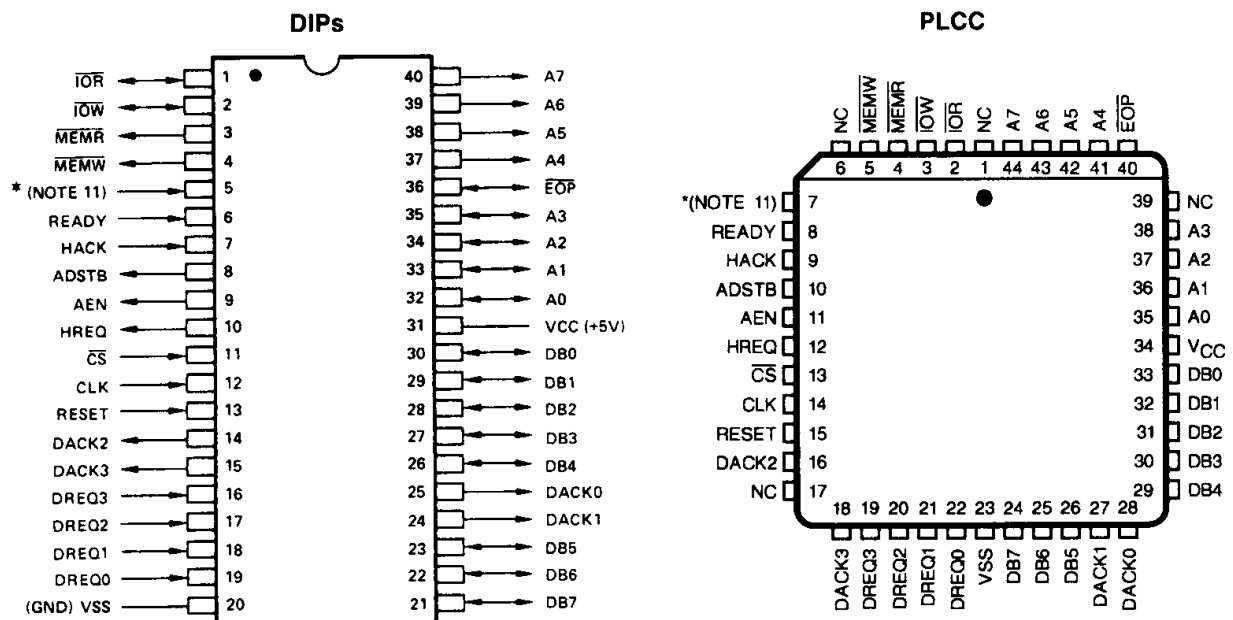

CD005072

CD009911

Note: Pin 1 is marked for orientation.
*See Note 11 under DC Characteristics table.

ORDERING INFORMATION

Am9517A

AMD standard products are available in several packages and operating ranges. The order number (Valid Combination) is formed by a combination of:

- a. **Device Number**
- b. **Speed Option** (if applicable)
- c. **Package Type**
- d. **Temperature Range**
- e. **Optional Processing**

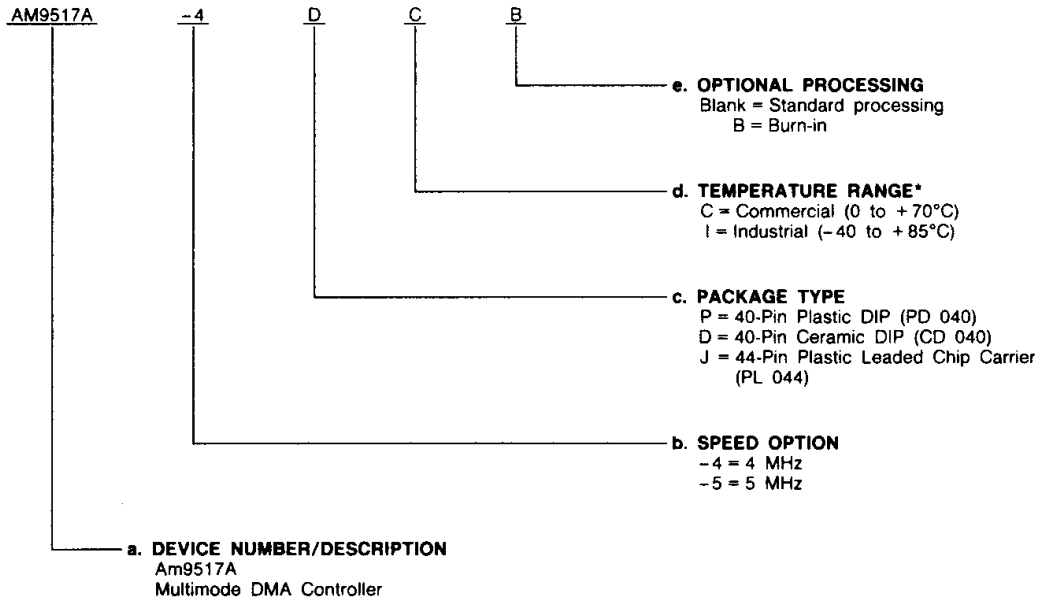

Valid Combinations

Valid Combinations	
AM9517A-4	DC, DCB, DIB, PC
AM9517A-5	DC, DCB, PC, JC

Valid Combinations list configurations planned to be supported in volume for this device. Consult the local AMD sales office to confirm availability of specific valid combinations, to check on newly released combinations, and to obtain additional data on AMD's standard military grade products.

1

ORDERING INFORMATION (continued)

8237A

AMD commodity products are available in several packages and operating ranges. The order number (Valid Combination) is formed by a combination of:

- a. Temperature Range
- b. Package Type
- c. Device Number
- d. Speed Option
- e. Optional Processing

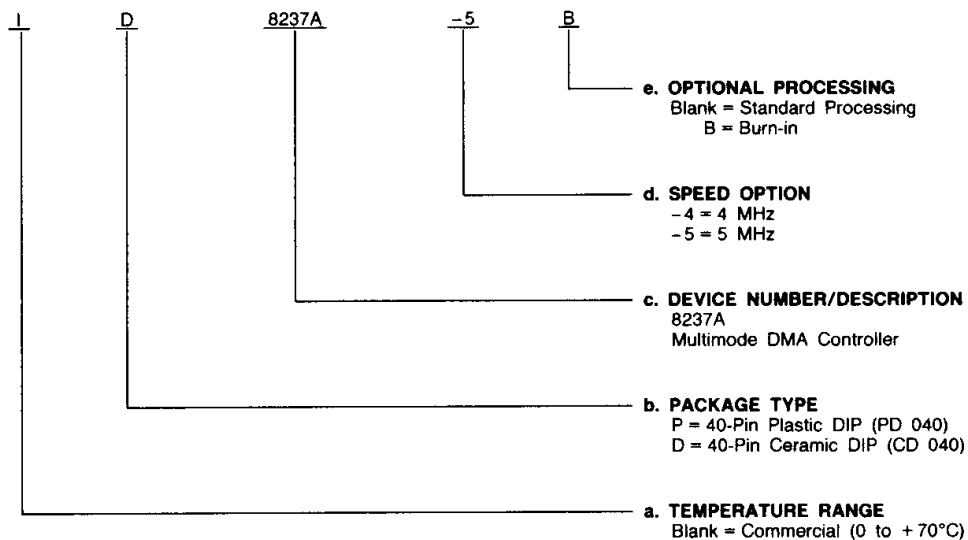

Valid Combinations	
8237A-4	P, D
8237A-5	
8237A-4B	D
8237A-5B	

Valid Combinations

Valid Combinations list configurations planned to be supported in volume for this device. Consult the local AMD sales office to confirm availability of specific valid combinations, to check on newly released valid combinations, and to obtain additional data on AMD's standard military grade products.

ORDERING INFORMATION (continued)

Standard Military Drawing (SMD)/DESC Products

AMD standard products for Aerospace and Defense applications are available in several packages and operating ranges. Standard Military Drawing (SMD)/DESC products are fully compliant with MIL-STD-883C requirements. The order number (Valid Combination) for SMD/DESC products is formed by a combination of:

- a. **Military Drawing Part Number**
- b. **Device Type**
- c. **Case Outline**
- d. **Lead Finish**

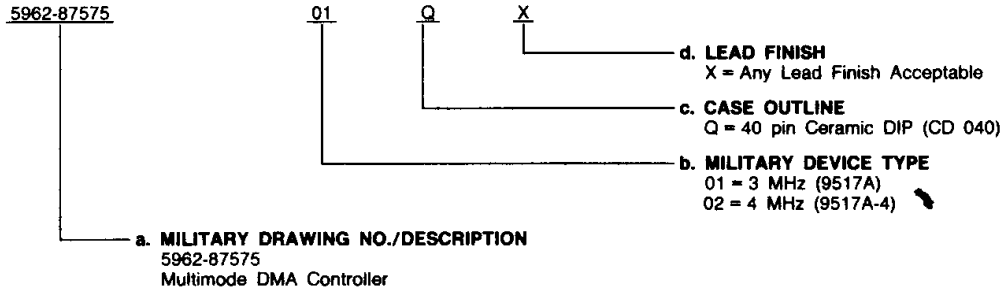

Valid Combinations	
5962-8757501	QX
5962-8757502	

Valid Combinations

Valid Combinations list configurations planned to be supported in volume for this device. Consult the local AMD sales office to confirm availability of specific valid combinations, to check on newly released combinations.

Group A Tests

Group A tests consist of Subgroups
1, 2, 3, 7, 8, 9, 10, 11.

ORDERING INFORMATION (continued)

APL Products

AMD products for Aerospace and Defense applications are available in several packages and operating ranges. APL (Approved Products List) products are fully compliant with MIL-STD-883C requirements. The order number (Valid Combination) for APL products is formed by a combination of:

- a. Device Number
- b. Speed Option (if applicable)
- c. Device Class
- d. Package Type
- e. Lead Finish

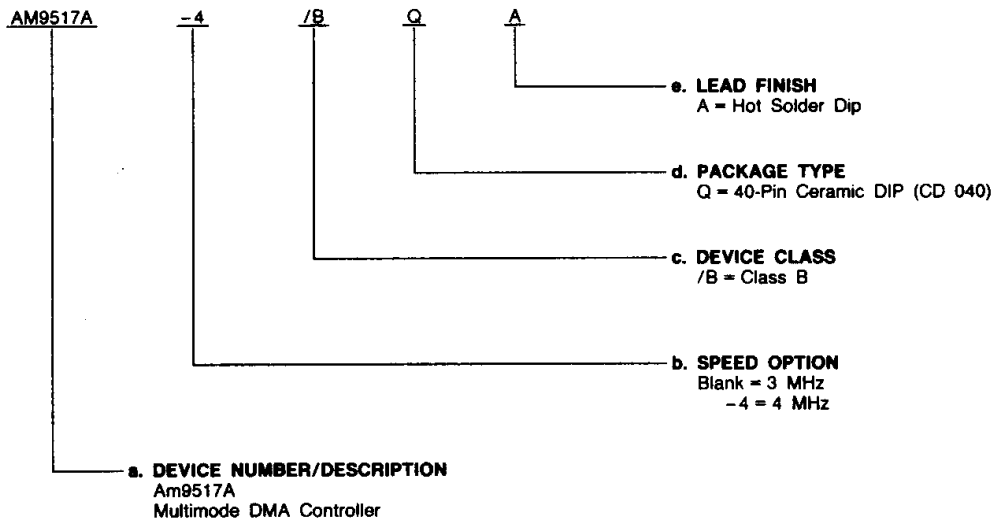

Valid Combinations	
AM9517A	/BQA
AM9517A-4	

Valid Combinations

Valid Combinations list configurations planned to be supported in volume for this device. Consult the local AMD sales office to confirm availability of specific valid combinations or to check for newly released valid combinations.

Group A Tests

Group A tests consist of Subgroups
1, 2, 3, 7, 8, 9, 10, 11.

PIN DESCRIPTION

Pin No.*	Name	I/O	Description
31	VCC		Power: +5 volt supply.
20	VSS		Ground.
12	CLK	I	Clock Input: Clock Input controls the internal operations of the Am9517A/8237A and its rate of data transfers. The input may be driven at up to 3MHz for the standard Am9517A/8237A and up to 5 MHz for the Am9517A-5/8237A-5.
11	CS	I	Chip Select: Chip Select is an active low input used to select the Am9517A/8237A as an I/O device during the Idle cycle. This allows CPU communication on the data bus.
13	RESET	I	Reset: Reset is an active high input which clears the Command, Status, Request and Temporary registers. It also clears the First/Last Flip/Flop and sets the Mask register. Following a Reset the device is in the Idle cycle.
6	READY	I	Ready: Ready is an input used to extend the memory read and write pulses from the Am9517A/8237A to accommodate slow memories or I/O peripheral devices. Ready must not make transitions during its specified setup/hold time.
7	HACK	I	Hold Acknowledge: The active high Hold Acknowledge from the CPU indicates that it has relinquished control of the system buses.
19-16	DREQ0-DREQ3	I	DMA Request: The DMA Request lines are individual asynchronous channel request inputs used by peripheral circuits to obtain DMA service. In Fixed Priority, DREQ0 has the highest priority and DREQ3 has the lowest priority. A request is generated by activating the DREQ line of a channel. DACK will acknowledge the recognition of DREQ signal. Polarity of DREQ is programmable. Reset initializes these lines to active high. DREQ must be maintained until the corresponding DACK goes active.
30-26, 23-21	DB0-DB7	I/O	DATA Bus: The Data Bus lines are bidirectional three-state signals connected to the system data bus. The outputs are enabled in the Program condition during the I/O Read to output the contents of an Address register, a Status register, the Temporary register or a Word Count register to the CPU. The outputs are disabled and the inputs are read during an I/O Write cycle when the CPU is programming the Am9517A/8237A control registers. During DMA cycles the most significant 8 bits of the address are output onto the data bus to be strobed into an external latch by ADSTB. In memory-to-memory operations, data from the memory comes into the Am9517A/8237A on the data bus during the read-from-memory transfer. In the write-to-memory transfer, the data bus outputs place the data into the new memory location.
1	IOR	I/O	I/O Read: I/O Read is a bidirectional active low three-state line. In the Idle cycle, it is an input control signal used by the CPU to read the control registers. In the Active cycle, it is an output control signal used by the Am9517A/8237A to access data from a peripheral during a DMA Write transfer.
2	IOW	I/O	I/O Write: I/O Write is a bidirectional active low three-state line. In the Idle cycle, it is an input control signal used by the CPU to load information into the Am9517A/8237A. In the Active cycle, it is an output control signal used by the Am9517A/8237A to load data to the peripheral during a DMA Read transfer.
36	EOP	I/O	End of Process: End of Process is an active low bidirectional open-drain signal. Information concerning the completion of DMA service is available at the bidirectional EOP pin. The Am9517A/8237A allows an external signal to terminate an active DMA service. This is accomplished by pulling the EOP input low with an external EOP signal. The Am9517A/8237A also generates a pulse when the terminal count (TC) for any channel is reached. This generates an EOP signal which is output through the EOP Line. The reception of EOP, either internal or external, will cause the Am9517A/8237A to terminate the service, reset the request, and, if Autoinitialize is enabled, to write the base registers to the current registers of that channel. The mask bit and TC bit in the status word will be set for the currently active channel by EOP unless the channel is programmed for Autoinitialize. In that case, the mask bit remains unchanged. During memory-to-memory transfers, EOP will be output when the TC for channel 1 occurs. EOP should be tied high with a pull-up resistor if it is not used to prevent erroneous end of process inputs.
32-35	A0-A3	I/O	Address: The four least significant address lines are bidirectional three-state signals. In the Idle cycle, they are inputs and are used by the CPU to address the registers to be load or read. In the Active cycle, they are outputs and provide the lower 4 bits of the output address.
37-40	A4-A7	O	Address: The four most significant address lines are three-state outputs and provide 4 bits of address. These lines are enabled only during DMA service.
10	HREQ	O	Hold Request: This is the Hold Request to the CPU and is used to request control of the system bus. If the corresponding mask bit is clear, the presence of any valid DREQ causes the Am9517A/8237A to issue the HRQ. After HRQ goes active, at least one clock cycle (TCY) must occur before HLDA goes active.
25, 24 14, 15	DACK0-DACK3	O	DMA Acknowledge: DMA Acknowledge is used to notify the individual peripherals when one has been granted a DMA cycle. The sense of these lines is programmable. Reset initializes them to active low.
9	AEN	O	Address Enable. Address Enable enables the 8-bit latch containing the upper 8 address bits onto the system address bus. AEN can also be used to disable in other system bus drivers during DMA transfers. AEN is active-high.
8	ADSTB	O	Address Strobe. The active-high Address Strobe is used to strobe the upper address byte into an external latch.
3	MEMR	O	Memory Read: The Memory Read signal is an active low three-state output used to access data from the selected memory location during a DMA Read or a memory-to-memory transfer.
4	MEMW	O	Memory Write: The Memory Write signal is an active low three-state output used to write data to the selected memory location during a DMA Write or a a memory-to-memory transfer.

*Applies to. DIPs only.

Name	Size	Number
Base Address Registers	16 bits	4
Base Word Count Registers	16 bits	4
Current Address Registers	16 bits	4
Current Word Count Registers	16 bits	4
Temporary Address Register	16 bits	1
Temporary Word Count Register	16 bits	1
Status Register	8 bits	1
Command Register	8 bits	1
Temporary Register	8 bits	1
Mode Registers	6 bits	4
Mask Register	4 bits	1
Request Register	4 bits	1

Am9517/8237A Internal Registers.

DETAILED DESCRIPTION

The Am9517A/8237A block diagram includes the major logic blocks and all of the internal registers. The data interconnection paths are also shown. Not shown are the various control signals between the blocks. The Am9517A/8237A contains 344 bits of internal memory in the form of registers. The table shown above lists these registers by name and shows the size of each. A detailed description of the registers and their functions can be found under Register Description.

The Am9517A/8237A contains three basic blocks of control logic. The Timing Control block generates internal timing and external control signals for the Am9517A/8237A. The Program Command Control block decodes the various commands given to the Am9517A/8237A by the microprocessor prior to servicing a DMA Request. It also decodes each channel's Mode Control word. The Priority Encoder block resolves priority contention among DMA channels requesting service simultaneously.

The Timing Control block derives internal timing from the clock input. In Am9080A systems this input will usually be the $\phi 2$ TTL clock from an Am8224. However, any appropriate system clock will suffice.

DMA Operation

The Am9517A/8237A is designed to operate in two major cycles. These are called Idle and Active cycles. Each device cycle is made up of a number of states. The Am9517A/8237A can assume seven separate states, each composed of one full clock period. State I (SI) is the inactive state. It is entered when the Am9517A/8237A has no valid DMA requests pending. While in SI, the DMA controller is inactive but may be in the Program Condition, being programmed by the processor. State 0 (S0) is the first state of a DMA service. The Am9517A/8237A has requested a hold but the processor has not yet returned an acknowledge. An acknowledge from the CPU will signal that transfers may begin. S1, S2, S3, and S4 are the working states of the DMA service. If more time is needed to complete a transfer than is available with normal timing, wait states (SW) can be inserted before S4 by the use of the Ready line on the Am9517A/8237A.

Memory-to-memory transfers require a read-from and a write-to-memory to complete each transfer. The states, which resemble the normal working states, use two digit numbers for identification. Eight states are required for each complete transfer. The first four states (S11, S12, S13, S14) are used for the read-from-memory half and the last four states (S21, S22, S23 and S24) for the write-to-memory half of the transfer. The Temporary Data register is used for intermediate storage of the memory byte.

Idle Cycle

When no channel is requesting service, the Am9517A/8237A will enter the Idle cycle and perform "SI" states. In this cycle the Am9517A/8237A will sample the DREQ lines every clock cycle to determine if any channel is requesting a DMA service. The device will also sample \overline{CS} , looking for an attempt by the microprocessor to write or read the internal registers of the Am9517A/8237A. When \overline{CS} is LOW and HACK is LOW, the Am9517A/8237A enters the Program Condition. The CPU can now establish, change or inspect the internal definition of the part by reading from or writing to the internal registers. Address lines A0 - A3 are inputs to the device and select which registers will be read or written. The \overline{IOF} and \overline{IOW} lines are used to select and time reads or writes. Due to the number and size of the internal registers, an internal flip/flop is used to generate an additional bit of address. This bit is used to determine the upper or lower byte of the 16-bit Address and Word Count registers. The flip/flop is reset by Master Clear or Reset. A separate software command can also reset this flip/flop.

Special software commands can be executed by the Am9517A/8237A in the Program Condition. These commands are decoded as sets of addresses when both \overline{CS} and \overline{IOW} are active and do not make use of the data bus. Functions include Clear First/Last Flip/Flop and Master Clear.

Active Cycle

When the Am9517A/8237A is in the idle cycle and a channel requests a DMA service, the device will output a HREQ to the microprocessor and enter the Active cycle. It is in this cycle that the DMA service will take place in one of four modes:

Single Transfer Mode: In Single Transfer mode, the Am9517A/8237A will make a one-byte transfer during each HREQ/HACK handshake. When DREQ goes active, HREQ will go active. After the CPU responds by driving HACK active, a one-byte transfer will take place. Following the transfer, HREQ will go inactive, the word count will be decremented and the address will be either incremented or decremented. When the word count goes to zero, a Terminal Count (TC) will cause an Autoinitialize if the channel has been programmed to do so.

To perform a single transfer, DREQ must be held active only until the corresponding DACK goes active. If DREQ is held continuously active, HREQ will go inactive following each transfer and then will go active again and a new one-byte transfer will be made following each rising edge of HACK. In 8080A/Am9080A systems, this will ensure one full machine cycle of execution between DMA transfers. Details of timing between the Am9517A/8237A and other bus control protocols will depend upon the characteristics of the microprocessor involved.

Block Transfer Mode: In Block Transfer mode, the Am9517A/8237A will continue making transfers until a TC (caused by the word count going to zero) or an external End of Process (EOP) is encountered. DREQ need be held active only until DACK becomes active. An Autoinitialize will occur at the end of the service if the channel has been programmed for it.

Demand Transfer Mode: In Demand Transfer mode the device will continue making transfers until a TC or external EOP is encountered or until DREQ goes inactive. Thus, the device requesting service may discontinue transfers by bringing DREQ inactive. Service may be resumed by asserting an active DREQ once again. During the time between services when the microprocessor is allowed to operate, the intermediate values of address and word count may be read from the Am9517A/8237A Current Address and Current Word Count

registers. Autoinitialization will only occur following a TC or \overline{EOP} at the end of service. Following Autoinitialization, an active-going DREQ edge is required to initiate a new DMA service.

Cascade Mode: This mode is used to cascade more than one Am9517A/8237A together for simple system expansion. The HREQ and HACK signals from the additional Am9517A/8237A are connected to the DREQ and DACK signals of a channel of the initial Am9517A/8237A. This allows the DMA requests of the additional device to propagate through the priority network circuitry of the preceding device. The priority chain is preserved and the new device must wait for its turn to acknowledge requests. Since the cascade channel in the initial device is used only for prioritizing the additional device, it does not output any address or control signals of its own. These would conflict with the outputs of the active channel in the added device. The Am9517A/8237A will respond to DREQ with DACK but all other outputs except HREQ will be disabled.

Figure 1 shows two additional devices cascaded into an initial device using two of the previous channels. This forms a two level DMA system. More Am9517A/8237As could be added at the second level by using the remaining channels of the first level. Additional devices can also be added by cascading into the channels of the second level devices forming a third level.

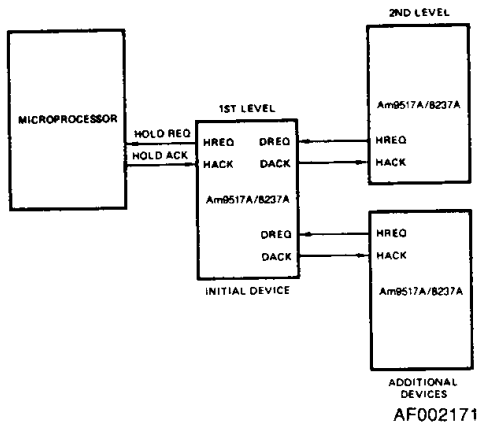

Figure 1. Cascaded Am9517A/8237As

Transfer Types

Each of the three active transfer modes can perform three different types of transfers. These are Read, Write and Verify. Write transfers move data from an I/O device to the memory by activating \overline{IOR} and \overline{MEMW} . Read transfers move data from memory to an I/O device by activating \overline{MEMR} and \overline{IOW} . Verify transfers are pseudo transfers; the Am9517A/8237A operates as in Read or Write transfers generating addresses, responding to \overline{EOP} , etc. However, the memory and I/O control lines remain inactive.

Memory-to-Memory: The Am9517A/8237A includes a block move capability that allows blocks of data to be moved from one memory address space to another. When Bit C0 in the Command register is set to a logical 1, channels 0 and 1 will operate as memory-to-memory transfer channels. Channel 0 forms the source address and channel 1 forms the destination address. The channel 1 word count is used. A memory-to-memory transfer is initiated by setting a software DMA request for channel 0. Block Transfer Mode should be used for memory-to-memory. When channel 0 is programmed for a fixed source address, a single source word may be written into a block of memory.

When setting up the Am9517A/8237A for memory-to-memory operation, it is suggested that both channels 0 and 1 be masked out. Further, the channel 0 word count should be initialized to the same value used in channel 1. No DACK outputs will be active during memory-to-memory transfers.

The Am9517A/8237A will respond to external \overline{EOP} signals during memory-to-memory transfers. Data comparators in block search schemes may use this input to terminate the service when a match is found. The timing of memory-to-memory transfers may be found in Timing Diagram 2.

Autoinitialize: By programming a bit in the Mode register, a channel may be set up for an Autoinitialize operation. During Autoinitialization, the original values of the Current Address and Current Word Count registers are automatically restored from the Base Address and Base Word Count registers of that channel following \overline{EOP} . The base registers are loaded simultaneously with the current registers by the microprocessor and remain unchanged throughout the DMA service. The mask bit is not set by \overline{EOP} when the channel is in Autoinitialize. Following Autoinitialize the channel is ready to repeat its service without CPU intervention.

Priority: The Am9517A/8237A has two types of priority encoding available as software selectable options. The first is Fixed Priority which fixes the channels in priority order based upon the descending value of their number. The channel with the lowest priority is 3 followed by 2, 1 and the highest priority channel, 0.

The second scheme is Rotating Priority. The last channel to get service becomes the lowest priority channel with the others rotating accordingly. With Rotating Priority in a single chip DMA system, any device requesting service is guaranteed to be recognized after no more than three higher priority services have occurred. This prevents any one channel from monopolizing the system.

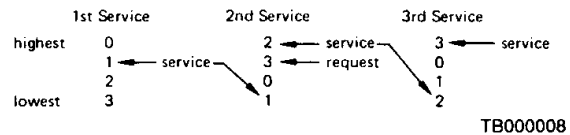

TB000008

The priority encoder selects the highest priority channel requesting service on each active-going HACK edge. Once a channel is started, its operation will not be suspended if a request is received by a higher priority channel. The high priority channel will only gain control after the lower priority channel releases HREQ. When control is passed from one channel to another, the CPU will always gain bus control. This ensures generation of rising HACK edge to be used to initiate selection of the new highest-priority requesting channel.

Compressed Timing: To achieve even greater throughput where system characteristics permit, the Am9517A/8237A can compress the transfer time to two clock cycles. From Timing Diagram 3 it can be seen that state S3 is used to extend the access time of the read pulse. By removing state S3 the read pulse width is made equal to the write pulse width, and a transfer consists only of state S2 to change the address and state S4 to perform the read/write. S1 states will still occur when A8 - A15 need updating (see Address Generation). Timing for compressed transfers is found in Timing Diagram 4.

Extended Write: For Flyby Transactions late write is normally used, as this allows sufficient time for the \overline{IOR} signal to get data from the peripheral onto the bus before \overline{MEMW} is activated. In some systems, performance can be improved by starting the write cycle earlier. This is especially true for memory-to-memory transactions.

Address Generation: To reduce pin count, the Am9517A/8237A multiplexes the eight higher order address bits on the data lines. State S1 is used to output the higher order address bits to an external latch from which they may be placed on the address bus. The falling edge of Address Strobe (ADSTB) is used to load these bits from the data lines to the latch. Address Enable (AEN) is used to enable the bits onto the address bus through a three-state enable. The lower order address bits are output by the Am9517A/8237A directly. Lines A0 - A7 should be connected to the address bus. Timing Diagram 1 shows the time relationships between CLK, AEN, ADSTB, DB0 - DB7 and A0 - A7.

During Block and Demand Transfer mode services which include multiple transfers, the addresses generated will be sequential. For many transfers the data held in the external address latch will remain the same. This data need only change when a carry or borrow from A7 to A8 takes place in the normal sequence of addresses. To save time and speed transfers, the Am9517A/8237A executes S1 states only when updating of A8 - A15 in the latch is necessary. This means for long services that S1 states may occur only once every 256 transfers, a savings of 255 clock cycles for each 256 transfers.

Register Description

Current Address Register: Each channel has a 16-bit Current Address register. This register holds the value of the address used during DMA transfers. The address is automatically incremented or decremented after each transfer and the intermediate values of the address are stored in the Current Address register during the transfer. This register is written or read by the microprocessor in successive 8-bit bytes. It may also be reinitialized by an Autoinitialize back to its original value. Autoinitialization takes place only after an \overline{EOP} .

Current Word Count Register: Each channel has a 16-bit Current Word Count register. This register should be programmed with, and will return on a CPU read, a value one less than the number of words to be transferred. The word count is decremented after each transfer. The intermediate value of the word count is stored in the register during the transfer. When the value in the register goes to zero, a TC will be generated. This register is loaded or read in successive 8-bit bytes by the microprocessor in the Program Condition. Following the end of a DMA service, it may also be reinitialized by an Autoinitialize back to its original value. Autoinitialize can occur only when an \overline{EOP} occurs. Note that the contents of the Word Count register will be FFFF (hex) following on internally generated \overline{EOP} .

Base Address and Base Word Count Registers: Each channel has a pair of Base Address and Base Word Count registers. These 16-bit registers store the original values of their associated current registers. During Autoinitialize these values are used to restore the current registers to their original values. The base registers are written simultaneously with their corresponding current register in 8-bit bytes during DMA, programming by the microprocessor. Accordingly, writing to these registers when intermediate values are in the Current registers will overwrite the intermediate values. The Base registers cannot be read by the microprocessor.

Command Register: This 8-bit register controls the operation of the Am9517A/8237A. It is programmed by the microprocessor in the Program Condition and is cleared by Reset. The following table lists the function of the command bits. See Figure 2 for address coding.

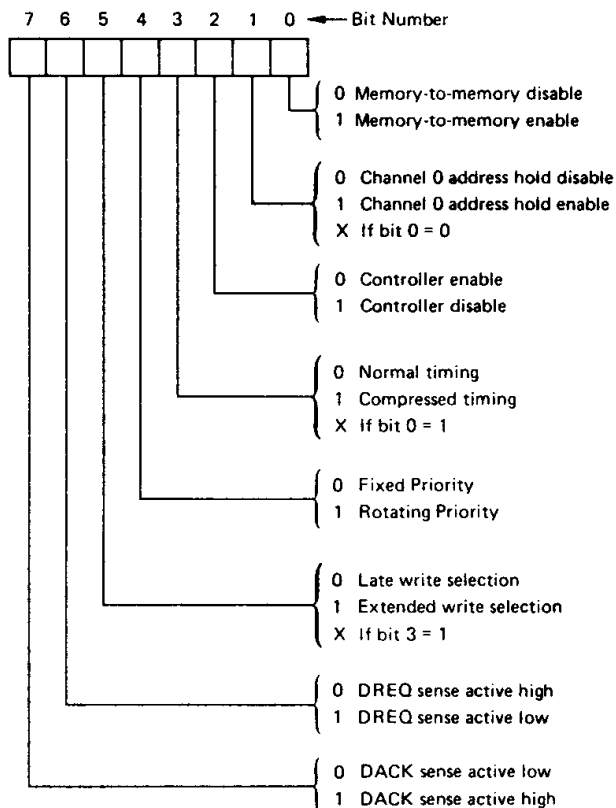

DF000970

Mode Register: Each channel has a 6-bit Mode register associated with it. When the register is being written to by the microprocessor in the Program Condition, bits 0 and 1 determine which channel Mode register is to be written to.

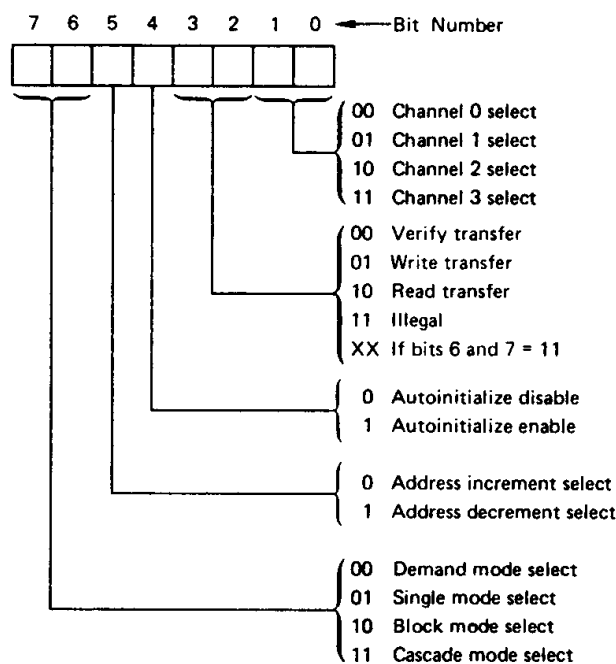

DF000980

Request Register: The Am9517A/8237A can respond to requests for DMA service which are initiated by software as well as by a DREQ. Each channel has a request bit associated with it in the 4-bit Request register. These are nonmaskable and subject to prioritization by the Priority Encoder network.

Each register bit is set or reset separately under software control or is cleared upon generation of a TC or external EOP. The entire register is cleared by a Reset. To set or reset a bit, the software loads the proper form of the data word. See Figure 2 for address coding.

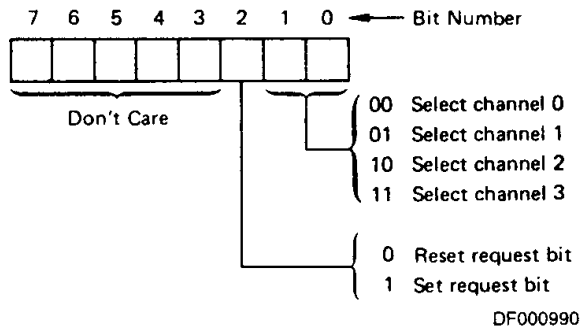

Software requests will be serviced only if the channel is in Block mode. When initiating a memory-to-memory transfer, the software request for channel 0 should be set.

Mask Register: Each channel has associated with it a mask bit which can be set to disable the incoming DREQ. Each mask bit is set when its associated channel produces an EOP if the channel is not programmed for Autoinitialize. Each bit of the 4-bit Mask register may also be set or cleared separately under software control. The entire register is also set by a Reset. This disables all DMA requests until a clear Mask register instruction allows them to occur. The instruction to separately set or clear the mask bits is similar in form to that used with the Request register. See Figure 2 for instruction addressing.

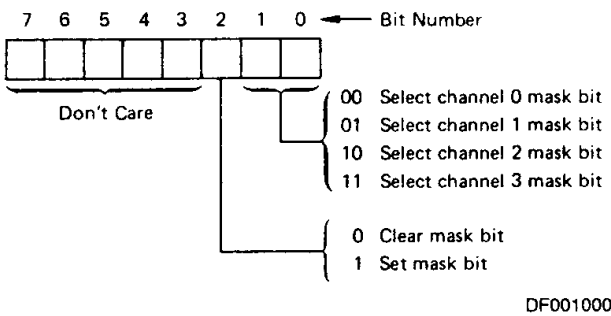

All four bits of the Mask Register may also be written with a single command.

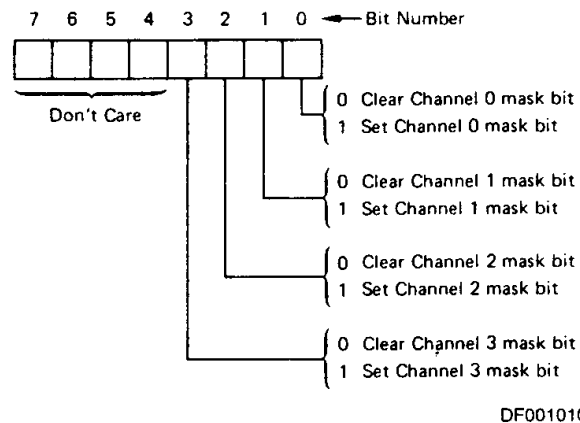

Status Register: The Status registers may be read out of the Am9517A/8237A by the microprocessor. It indicates which channels have reached a terminal count and which channels have pending DMA requests. Bits 0-3 are set each time a TC is reached by that channel, including after each Autoinitialization. These bits are cleared by Reset and each Status Read. Bits 4-7 are set whenever their corresponding channel is requesting service.

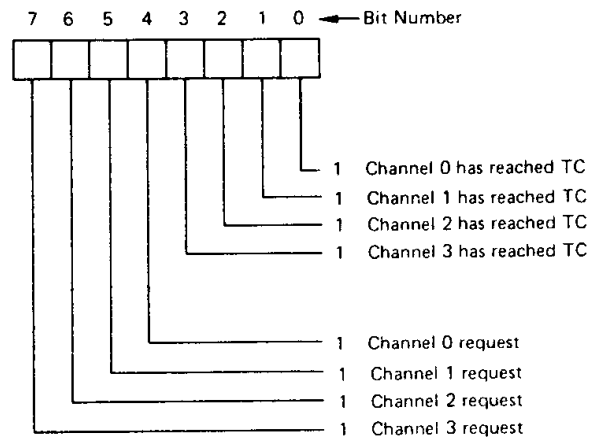

Temporary Register: The Temporary register is used to hold data during memory-to-memory transfers. Following the completion of the transfers, the last word moved can be read by the microprocessor in the Program Condition. The Temporary register always contains the last byte transferred in the previous memory-to-memory operation, unless cleared by a Reset.

Software Commands: There are three special software commands which can be executed in the Program Condition. They do not depend on any specific bit pattern on the data bus. The three software commands are:

Clear First/Last Flip/Flop: This command may be issued prior to writing or reading Am9517A/8237A address or word count information. This initializes the Flip/Flop to a known state so that subsequent accesses to register contents by the microprocessor will address lower and upper bytes in the correct sequence. When the Flip/Flop is cleared it addresses the lower byte and when set it addresses the upper byte.

Master Clear: This software instruction has the same effect as the hardware Reset. The Command, Status, Request, Temporary and Internal First/Last Flip/Flop registers are cleared and the Mask register is set. The Am9517A/8237A will enter the Idle cycle.

Clear Mask Register: This command clears the mask bits of all four channels, enabling them to accept DMA requests.

1

Interface Signals						Operation
A3	A2	A1	A0	$\overline{\text{IOR}}$	$\overline{\text{IOW}}$	
1	0	0	0	0	1	Read Status Register
1	0	0	0	1	0	Write Command Register
1	0	0	1	0	1	Illegal
1	0	0	1	1	0	Write Request Register
1	0	1	0	0	1	Illegal
1	0	1	0	1	0	Write Single Mask Register Bit
1	0	1	1	0	1	Illegal
1	0	1	1	1	0	Write Mode Register
1	1	0	0	0	1	Illegal
1	1	0	0	1	0	Clear Byte Pointer Flip/Flop
1	1	0	1	0	1	Read Temporary Register
1	1	0	1	1	0	Master Clear
1	1	1	0	0	1	Illegal
1	1	1	0	1	0	Clear Mask Register
1	1	1	1	0	1	Illegal
1	1	1	1	1	0	Write All Mask Register Bits

Figure 2. Register and Function Addressing

Channel	Register	Operation	Signals							Internal Flip/Flop	Data Bus DB0 – DB7
			$\overline{\text{CS}}$	$\overline{\text{IOR}}$	$\overline{\text{IOW}}$	A3	A2	A1	A0		
0	Base & Current Address	Write	0	1	0	0	0	0	0	0	A0 – A7 A8 – A15
	Current Address	Read	0	0	1	0	0	0	0	0	A0 – A7 A8 – A15
	Base & Current Word Count	Write	0	1	0	0	0	0	1	0	W0 – W7 W8 – W15
	Current Word Count	Read	0	0	1	0	0	0	1	0	W0 – W7 W8 – W15
1	Base & Current Address	Write	0	1	0	0	0	1	0	0	A0 – A7 A8 – A15
	Current Address	Read	0	0	1	0	0	1	0	0	A0 – A7 A8 – A15
	Base & Current Word Count	Write	0	1	0	0	0	1	1	0	W0 – W7 W8 – W15
	Current Word Count	Read	0	0	1	0	0	1	1	0	W0 – W7 W8 – W15
2	Base & Current Address	Write	0	1	0	0	1	0	0	0	A0 – A7 A8 – A15
	Current Address	Read	0	0	1	0	1	0	0	0	A0 – A7 A8 – A15
	Base & Current Word Count	Write	0	1	0	0	1	0	1	0	W0 – W7 W8 – W15
	Current Word Count	Read	0	0	1	0	1	0	1	0	W0 – W7 W8 – W15
3	Base & Current Address	Write	0	1	0	0	1	1	0	0	A0 – A7 A8 – A15
	Current Address	Read	0	0	1	0	1	1	0	0	A0 – A7 A8 – A15
	Base & Current Word Count	Write	0	1	0	0	1	1	1	0	W0 – W7 W8 – W15
	Current Word Count	Read	0	0	1	0	1	1	1	0	W0 – W7 W8 – W15

Figure 3. Word Count and Address Register Command Codes

APPLICATIONS INFORMATION

Figure 4 shows a convenient method for configuring a DMA system with the Am9517A/8237A Controller and a microprocessor system. The Multimode DMA Controller issues a Hold Request to the processor whenever there is at least one valid DMA Request from a peripheral device. When the processor replies with a Hold Acknowledge signal, the Am9517A/8237A takes control of the Address Bus, the Data Bus and the Control Bus. The address for the first transfer operation

comes out in two bytes – the least significant eight bits on the eight Address outputs and the most significant eight bits on the Data Bus. The contents of the Data Bus are then latched into the Am74LS373 register to complete the full 16 bits of the Address Bus. The Am74LS373 is a high-speed, low power, 8-bit, three-state register in a 20-pin package. After the initial transfer takes place, the register is updated only after a carry or borrow is generated in the least significant address byte. Four DMA channels are provided when one Am9517A/8237A is used.

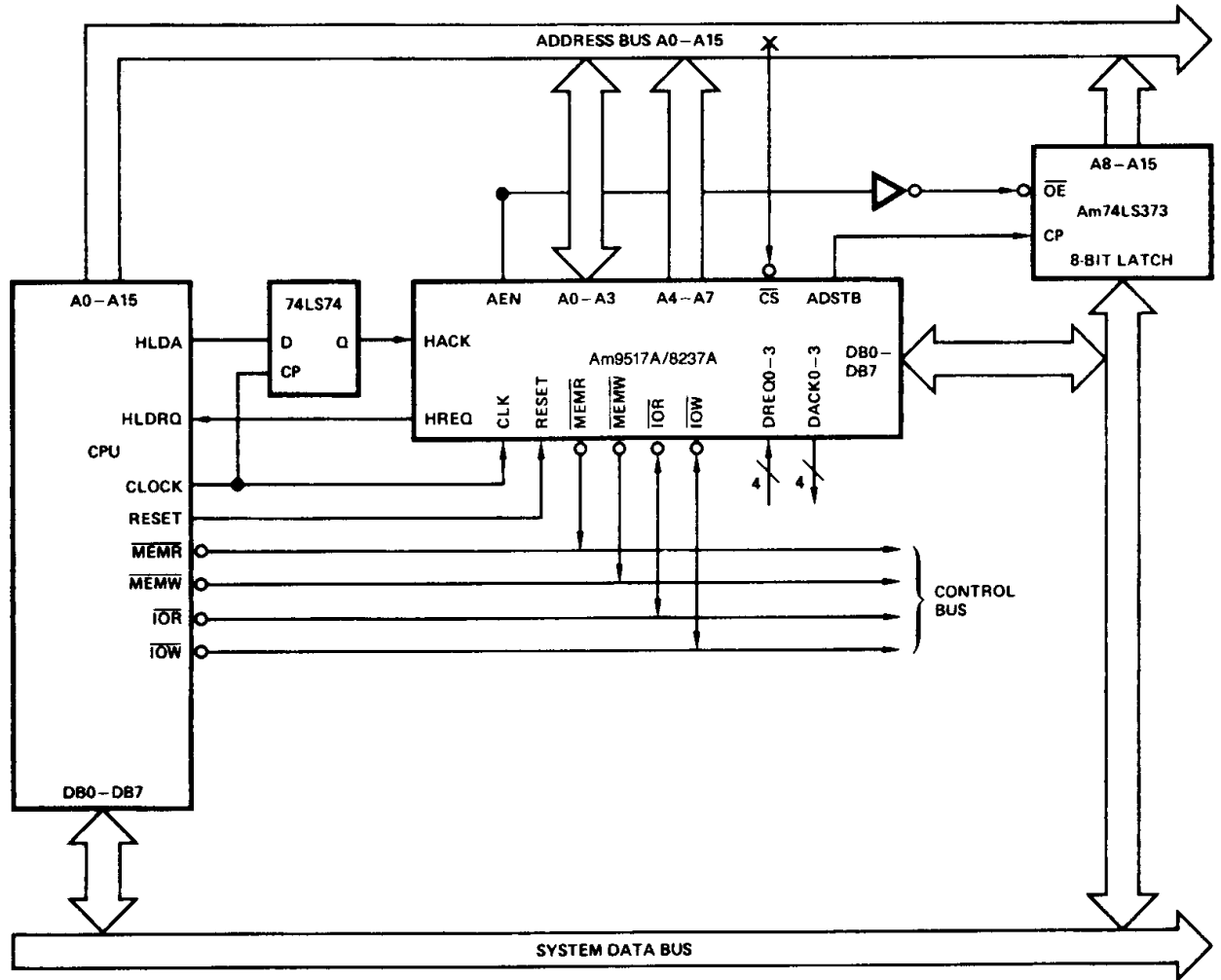

AF002182

Figure 4. Basic DMA Configuration

ABSOLUTE MAXIMUM RATINGS

Storage temperature -65 to +150°C
 VCC with Respect to VSS -0.5 to +7.0 V
 All Signal Voltages with Respect
 to VSS -0.5 V to +7.0 V
 Power Dissipation (Package Limitation) 1.5 W

Stresses above those listed under ABSOLUTE MAXIMUM RATINGS may cause permanent device failure. Functionality at or above these limits is not implied. Exposure to absolute maximum ratings for extended periods may affect device reliability.

OPERATING RANGES

Commercial (C) Devices
 Temperature (T_A) 0 to 70°C
 Supply Voltage (V_{CC}) 5 V ±5%

Industrial (I) Devices
 Temperature (T_A) -40 to +85°C
 Supply Voltage (V_{CC}) 5 V ±10%

Operating ranges define those limits between which the functionality of the device is guaranteed.

DC CHARACTERISTICS over COMMERCIAL operating ranges unless otherwise specified. (Note 1)

Parameters	Description	Test Conditions	Min	Typ	Max	Units
VOH	Output HIGH Voltage	IOH = -200 μA	2.4			Volts
		IOH = -100 μA, (HREQ Only)	3.3			
VOL	Output LOW Voltage	IOL = 3.2 mA			0.40 V	Volts
VIH	Input HIGH Voltage		2.0		VCC + 0.5	Volts
VIL	Input LOW Voltage		-0.5		0.8	Volts
IIX	Input Load Current	VSS ≤ VI ≤ VCC	-10		+10	μA
IOZ	Output Leakage Current	VCC ≤ VO ≤ VSS + 0.40	-10		+10	μA
ICC	VCC Supply Current	T _A = +25°C		65	130	mA
		T _A = 0°C		75	150	
CO	Output Capacitance (Note 14)	fc = 1.0 MHz, Inputs = 0 V		4	8	pF
CI	Input Capacitance			8	15	pF
CIO	I/O Capacitance			10	18	pF
COHREQ	Output Capacitance (HREQ)			18	20	pF

Notes:

- Typical values are for T_A = 25°C, nominal supply voltage and nominal processing parameters.
- Input timing parameters assume transition times of 20 ns or less. Waveform measurement points for both input and output signals are 2.0 V for HIGH and 0.8 V for LOW, unless otherwise noted.
- Output loading is 1 Standard TTL gate plus 50 pF capacitance unless noted otherwise.
- The new \overline{IOW} or \overline{MEMW} pulse width for normal write will be 2CY-100 ns and for extended write will be 2TCY-100 ns. The net \overline{IOR} or \overline{MEMR} pulse width for normal read will be 2CY-50 ns and for compressed read will be TCY-50 ns.
- TDQ is specified for two different output HIGH levels. TDQ1 is measured at 2.0 V. TDQ2 is measured at 3.3 V. The value for TDQ2 assumes an external 3.3 kΩ pull-up resistor connected from HREQ to VCC.
- DREQ should be held active until DACK is returned.
- DREQ and DACK signals may be active high or active low. Timing diagrams assume the active high mode.
- Output loading on the data bus is 1 Standard TTL gate plus 15 pF for the minimum value and 1 Standard TTL gate plus 100 pF for the maximum value.
- Successive read and/or write operations by the external processor to program or examine the controller must be timed to allow at least 450 ns for the Am9517A-4/8237A-4, and 400 ns for the Am9517A-5/8237A-5 as recovery time between active read or write pulses.
- Parameters are listed in alphabetical order.
- Pin 5 is an input that should always be at a logic high level. An internal pull-up resistor will establish a logic high when the pin is left floating. Alternatively, pin 5 may be tied to VCC.
- Signals \overline{READ} and \overline{WRITE} refer to \overline{IOR} and \overline{MEMW} respectively for peripheral-to-memory DMA operations and to \overline{MEMR} and \overline{IOW} respectively for memory-to-peripheral DMA operations.
- If N wait states are added during the write-to-memory half of a memory-to-memory transfer, this parameter will increase by N (TCY).
- All output pins except HREQ.
- Because \overline{EOP} high from clock high is load dependent, users wishing to test these parameters should use a 2k pull-up resistor and a tester with 50 pF or less load capacitance. Time constant RC = 120 ns is added to the specified number in the data sheet for testing.

SWITCHING TEST INPUT WAVEFORM

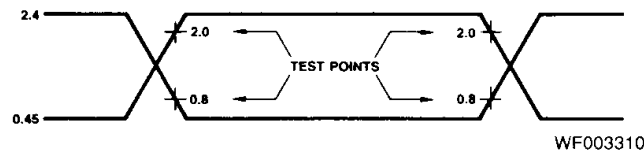

ABSOLUTE MAXIMUM RATINGS

Storage temperature -65 to +150°C
 V_{CC} with Respect to V_{SS} -0.5 to +7.0 V
 All Signal Voltages with Respect to V_{SS} .. -0.5 to +7.0 V
 Power Dissipation (Package Limitation) 1.5 W

Stresses above those listed under ABSOLUTE MAXIMUM RATINGS may cause permanent device failure. Functionality at or above these limits is not implied. Exposure to absolute maximum ratings for extended periods may affect device reliability.

OPERATING RANGES

Military (M) Devices
 Temperature (T_C) -55 to +125°C
 Supply Voltage (V_{CC}) 5 V \pm 10%

Operating ranges define those limits between which the functionality of the device is guaranteed.

DC CHARACTERISTICS over **MILITARY** operating range (for SMD/DESC and APL Products, Group A, Subgroups 1, 2, 3 are tested unless otherwise noted)

Parameter Symbol	Parameter Description	Test Conditions	Min.	Max.	Unit
V_{OH}	Output HIGH Voltage	$I_{OH} = -200 \mu A, V_{CC} = 4.5 V$	2.4		V
		$I_{OH} = -100 \mu A, (HREQ \text{ Only})$	3.3		
V_{OL}	Output LOW Voltage	$I_{OL} = 3.2 \text{ mA}, V_{CC} = 5.5 V$		0.45 V	V
V_{IH}	Input HIGH Voltage	$V_{CC} = 4.5 V, 5.5 V$	2.2	$V_{CC} + 0.5^*$	V
V_{IHCLK}	Input HIGH Voltage	$V_{CC} = 4.5 V, 5.5 V (CLK \text{ Only})$	2.35	$V_{CC} + 0.5^*$	V
V_{IL}	Input LOW Voltage	$V_{CC} = 4.5 V, 5.5 V$	-0.5*	0.7	V
I_{IX}	Input Load Current	$V_{SS} \leq V_i \leq V_{CC}, V_{CC} = 5.5 V$	-10	+10	μA
I_{OZ}	Output Leakage Current	$V_{CC} \leq V_O \leq V_{SS} + 0.40, V_{CC} = 5.5 V$	-10	+10	μA
I_{CC}	V_{CC} Supply Current	(Note 1)		150	mA
$C_O \dagger$	Output Capacitance (Note 12)	$f_c = 1.0 \text{ MHz}, \text{ Inputs} = 0 V$		8*	pF
$C_I \dagger$	Input Capacitance			15*	pF
$C_{IO} \dagger$	I/O Capacitance		18*		pF

* Guaranteed by design.

† Not included in Group A tests.

Notes:

- I_{CC} is measured in a dynamic condition with outputs in a worst-case state having no loads applied.
- Input timing parameters assume transition times of 20 ns or less. Waveform measurement points for both input and output signals are 2.0 V for HIGH and 0.8 V for LOW, unless otherwise noted.
- The new \overline{IOW} or \overline{MEMW} pulse width for normal write will be $TCY-100$ ns and for extended write will be $2TCY-100$ ns. The net \overline{IOR} or \overline{MEMR} pulse width for normal read will be $2TCY-50$ ns and for compressed read will be $TCY-50$ ns.
- TDQ is specified for two different output HIGH levels. TDQ1 is measured at 2.0 V. TDQ2 is measured at 3.3 V. The value for TDQ2 assumes an external 3.3 k Ω pull-up resistor connected from HREQ to V_{CC} .
- DREQ should be held active until DACK is returned.
- DREQ and DACK signals may be active HIGH or active LOW. Timing diagrams assume the active-HIGH mode.
- Successive read and/or write operations by the external processor to program or examine the controller must be timed to allow at least 600 ns for the Am9517A, at least 450 ns for the Am9517A-4 as recovery time between active read or write pulses.
- Parameters are listed in alphabetical order.
- Pin 5 is an input that should always be at a logic-HIGH level. An internal pull-up resistor will establish a logic HIGH when the pin is left floating. Alternatively, pin 5 may be tied to V_{CC} .
- Signals \overline{READ} and \overline{WRITE} refer to \overline{IOR} and \overline{MEMW} respectively for peripheral-to-memory DMA operations and to \overline{MEMR} and \overline{IOW} respectively for memory-to-peripheral DMA operations.
- If N wait states are added during the write-to-memory half of a memory-to-memory transfer, this parameter will increase by N (TCY).
- All output pins except HREQ.
- Because \overline{EOP} HIGH from clock HIGH is load-dependent, users wishing to test these parameters should use a 2k pull-up resistor and a tester with 50 pF or less load capacitance. Time constant $R_C = 120$ ns is added to the specified number in the data sheet for testing.

1

SWITCHING CHARACTERISTICS over **COMMERCIAL** operating ranges unless otherwise specified
ACTIVE CYCLE (Notes 2, 3, 10, 11, and 12)

Parameters	Description	Am9517A-4/8237A-4		Am9517A-5/8237A-5		Units
		Min	Max	Min	Max	
TAEL	AEN HIGH from CLK LOW (S1) Delay Time		225		200	ns
TAET	AEN LOW from CLK HIGH (S1) Delay Time		150		130	ns
TAFAB	ADR Active to Float Delay from CLK HIGH		120		90	ns
TAFC	READ or WRITE Float from CLK HIGH		120		120	ns
TAFDB	DB Active to Float Delay from CLK HIGH		190		170	ns
TAHR	ADR from READ HIGH Hold Time	TCY-100		TCY-100		ns
TAHS	DB from ADSTB LOW Hold Time	30		30		ns
TAHW	ADR from WRITE HIGH Hold Time	TCY-50		TCY-50		ns
TAK	DACK Valid from CLK LOW Delay Time		220		170	ns
	EOP HIGH from CLK HIGH Delay Time		190		170	ns
	EOP LOW to CLK HIGH Delay Time		190		170	ns
TASM	ADR Stable from CLK HIGH		190		170	ns
TASS	DB to ADSTB LOW Set-up Time	100		100		ns
TCH	Clock High Time (Transitions ≤ 10ns)	100		80		ns
TCL	Clock Low Time (Transitions ≤ 10ns)	110		68		ns
TCY	CLK Cycle Time	250		200		ns
TDCL	CLK HIGH to READ or WRITE LOW Delay (Note 4)		200		190	ns
TDCTR	Read HIGH from CLK HIGH (S4) Delay Time (Note 4)		210		190	ns
TDCTW	WRITE HIGH from CLK HIGH (S4) Delay Time (Note 4)		150		130	ns
TDQ1	HREQ Valid from CLK HIGH Delay Time (Note 5)		120		120	ns
TDQ2			190		120	ns
TEPS	EOP LOW from CLK LOW Set-up Time	45		40		ns
TEPW	EOP Pulse Width	225		220		ns
TFAAB	ADR Float to Active Delay from CLK HIGH		190		170	ns
TFAC	READ or WRITE Active from CLK HIGH		150		150	ns
TFADB	DB Float to Active Delay from CLK HIGH		225		200	ns
THS	HACK Valid to CLK HIGH Set-up Time	75		75		ns
TIDH	Input Data from MEMR HIGH Hold Time	0		0		ns
TIDS	Input Data to MEMR HIGH Set-up Time	190		170		ns
TODH	Output Data from MEMW HIGH Hold Time	20		10		ns
TODV	Output Data Valid to MEMW HIGH (Note 13)	125		125		ns
TQS	DREQ to CLK LOW (S1, S4) Set-up Time	0		0		ns
TRH	CLK to READY LOW Hold Time	20		20		ns
TRS	READY to CLK LOW Set-up Time	60		60		ns
TSTL	ADSTB HIGH from CLK HIGH Delay Time		150		130	ns
TSTT	ADSTB LOW from CLK HIGH Delay Time		110		90	ns
TQH	DREQ from DACK Valid Hold Time	0		0		ns
TRQHA	HREQ to HACK Delay Time	1		1		c/k

PROGRAM CONDITION (Idle Cycle) (Notes 2, 3, 10, and 11)

TAR	ADR Valid or CS LOW to READ LOW	50		50		ns
TAW	ADR Valid to WRITE HIGH Set-up Time	150		130		ns
TCW	CS LOW to WRITE HIGH Set-up Time	150		130		ns
TDW	Data Valid to WRITE HIGH Set-up Time	150		130		ns
TRA	ADR or CS Hold from READ HIGH	0		0		ns
TRDE	Data Access from READ LOW (Note 8)		200		140	ns
TRDF	DB Float Delay from READ HIGH	20	100	0	70	ns
TRSTD	Power Supply HIGH to RESET LOW Set-up Time	500		500		μs
TRSTS	RESET to First IOWR	2TCY		2TCY		ns
TRSTW	RESET Pulse Width	300		300		ns
TRW	READ Width	250		200		ns
TWA	ADR from WRITE HIGH Hold Time	20		20		ns
TWC	CS HIGH from WRITE HIGH Hold Time	20		20		ns
TWD	Data from WRITE HIGH Hold Time	30		30		ns
TWWS	Write Width	200		160		ns

Notes: See notes under DC Characteristics table.

SWITCHING CHARACTERISTICS over **MILITARY** operating range (for SMD/DESC and APL Products, Group A, Subgroups 9, 10, 11 are tested unless otherwise noted)

ACTIVE CYCLE (Notes 2, 8, 9, and 10)

Parameters	Description	Am9517A		Am9517A-4		Unit
		Min.	Max.	Min.	Max.	
TAEL	AEN HIGH from CLK LOW (S1) Delay Time		300		225	ns
TAET	AEN LOW from CLK HIGH (S1) Delay Time		200		150	ns
TAFAB	ADR Active to Float Delay from CLK HIGH		150		120	ns
T AFC	READ or WRITE Float from CLK HIGH		150		120	ns
TAFDB	DB Active to Float Delay from CLK HIGH		250		190	ns
TAHR	ADR from READ HIGH Hold Time	TCY-100		TCY-100		ns
TAHS	DB from ADSTB LOW Hold Time	30		30		ns
TAHW	ADR from WRITE HIGH Hold Time	TCY-50		TCY-50		ns
TAK	DACK Valid from CLK LOW Delay Time		280		220	ns
	EOP HIGH from CLK HIGH Delay Time		250		190	ns
	EOP LOW to CLK HIGH Delay Time		250		190	ns
TASM	ADR Stable from CLK HIGH		250		190	ns
TASS	DB to ADSTB LOW Setup Time	100		100		ns
TCH	Clock High Time (Transitions \leq 10ns)	120		100		ns
TCL	Clock Low Time (Transitions \leq 10ns)	150		110		ns
TCY	CLK Cycle Time	320		250		ns
TDCL	CLK HIGH to READ or WRITE LOW Delay (Note 3)		270		200	ns
TDCTR	Read HIGH from CLK HIGH (S4) Delay Time (Note 3)		270		210	ns
TDCTW	WRITE HIGH from CLK HIGH (S4) Delay Time (Note 3)		200		150	ns
TDQ1	HREQ Valid from CLK HIGH Delay Time (Note 4)		160		120	ns
TDQ2			2TCY + 250		2TCY + 190	ns
TEPS	EOP LOW from CLK LOW Setup Time	60		45		ns
TEPW	EOP Pulse Width	300		225		ns
TFAAB	ADR Float to Active Delay from CLK HIGH		250		190	ns
TFAC	READ or WRITE Active from CLK HIGH		200		150	ns
TFADB	DB Float to Active Delay from CLK HIGH		300		225	ns
THS	HACK Valid to CLK HIGH Setup Time	100		75		ns
TIDH	Input Data from MEMR HIGH Hold Time	0		0		ns
TIDS	Input Data to MEMR HIGH Setup Time	250		190		ns
TODH	Output Data from MEMW HIGH Hold Time	20		20		ns
TODV	Output Data Valid to MEMW HIGH (Note 11)	200		125		ns
TQS	DREQ to CLK LOW (S1, S4) Setup Time	0		0		ns
TRH	CLK to READY LOW Hold Time	20		20		ns
TRS	READY to CLK LOW Setup Time	100		60		ns
TSTL	ADSTB HIGH from CLK HIGH Delay Time		200		150	ns
TSTT	ADSTB LOW from CLK HIGH Delay Time		140		110	ns
TQH	DREQ from DACK Valid Hold Time	0		0		ns
TRQHA	HREQ to HACK Delay Time	1		1		clk

AC Device Test Conditions: $V_{CC} = 4.5 \text{ V}, 5.5 \text{ V}$
 $V_{IL} = 0.45 \text{ V}, V_{IH} = 2.4 \text{ V}$
 $V_{OL} = 0.8 \text{ V}, V_{OH} = 2.0 \text{ V}$
 $I_{OL} = 3.2 \text{ mA}, I_{OH} = 200 \mu\text{A}$
 $CL = 100 \text{ pF} \pm 20 \text{ pF}$

Notes: See notes following DC Characteristics.

1

SWITCHING CHARACTERISTICS over **MILITARY** operating range (continued)

PROGRAM CONDITION (Idle Cycle) (Notes 2, 3, 10, and 11)

Parameters	Description	Am9517A		Am9517A-4		Unit
		Min.	Max.	Min.	Max.	
TAR	ADR Valid or \overline{CS} LOW to \overline{READ} LOW	50		50		ns
TAW	ADR Valid to \overline{WRITE} HIGH Setup Time	200		150		ns
TCW	\overline{CS} LOW to \overline{WRITE} HIGH Setup Time	200		150		ns
TDW	Data Valid to \overline{WRITE} HIGH Setup Time	200		150		ns
TRA	ADR or \overline{CS} Hold from \overline{READ} HIGH	0		0		ns
TRDE	Data Access from \overline{READ} LOW (Note 8)		300		200	ns
TRDF	DB Float Delay from \overline{READ} HIGH	20	150	20	100	ns
TRSTD	Power Supply HIGH to RESET LOW Setup Time	500		500		μ s
TRSTS	RESET to First \overline{IOWR}	2TCY		2TCY		ns
TRSTW	RESET Pulse Width	300		300		ns
TRW	\overline{READ} Width	300		250		ns
TWA	ADR from \overline{WRITE} HIGH Hold Time	20		20		ns
TWC	\overline{CS} HIGH from \overline{WRITE} HIGH Hold Time	20		20		ns
TWD	Data from \overline{WRITE} HIGH Hold Time	30		30		ns
TWWS	Write Width	200		200		ns
TAD	Data Access from ADR Valid \overline{CS} LOW (TAD = TAR + TRDE)		300		300	ns

Notes: See notes following DC Characteristics.

SWITCHING WAVEFORMS (continued)

Timing Diagram 2. Memory-to-Memory

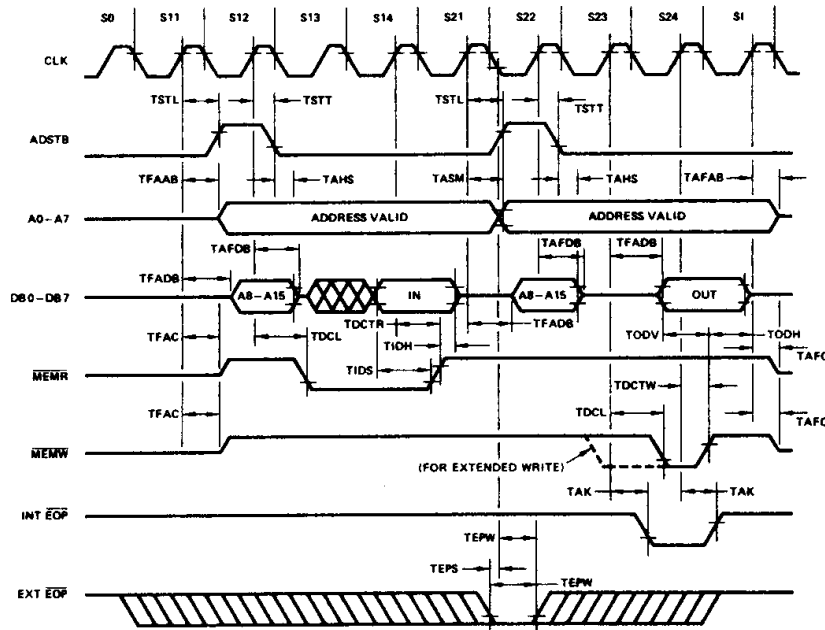

WF003320

Timing Diagram 3. Ready Timing

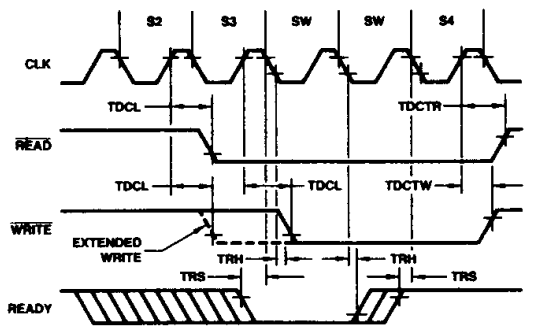

WF003330

Timing Diagram 4. Compressed Timing

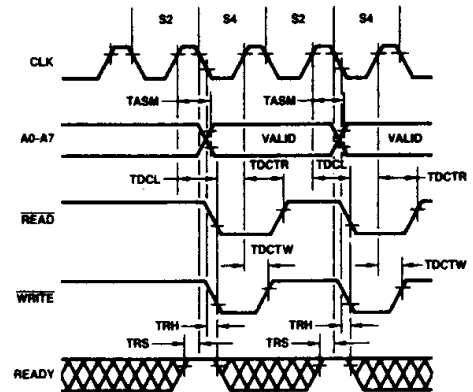

WF003340

Timing Diagram 5. Reset Timing

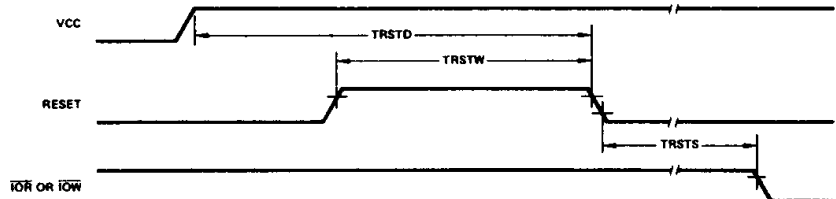

WF003350

SWITCHING WAVEFORMS (continued)

Timing Diagram 6. Program Condition Write Timing

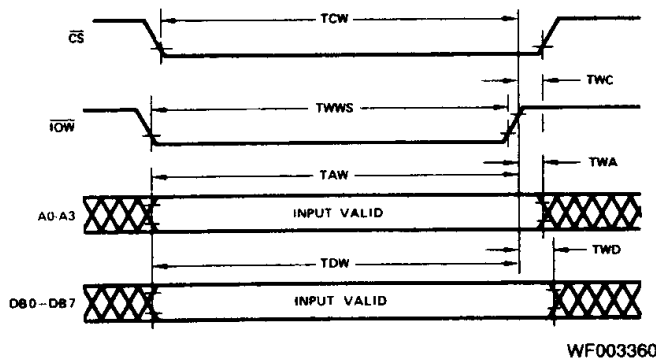

Timing Diagram 7. Program Condition Read Cycle

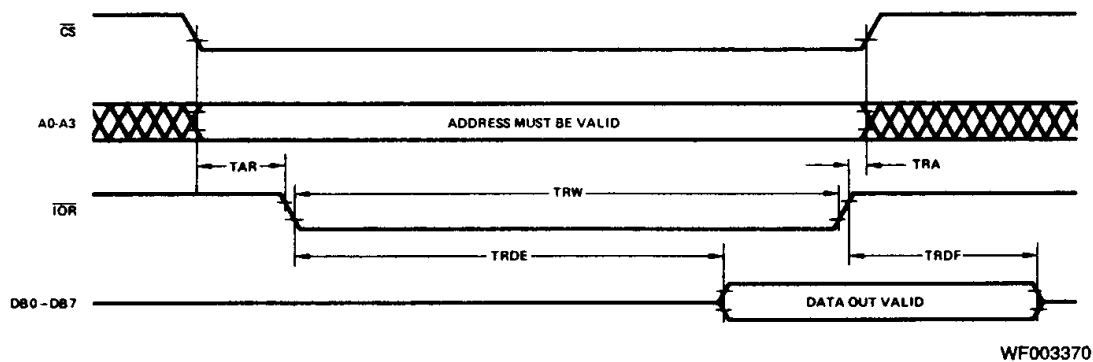

1