

INTRODUCTION

The KS0076B is a dot matrix LCD driver & controller LSI which is fabricated by low power CMOS technology.

FUNCTION

- Character type dot matrix LCD driver & controller
- Internal driver: 16 common and 40 segment signal output.
- Display character format; 5 x 7 dot + cursor, 5 x 10 dots + cursor
- Easy Interface with a 4-bit or 8-bit MPU
- Display character pattern:
5 x 7 dots format: 192 kinds, 5 x 10 dots format: 32 kinds
- The special character pattern can be programmable by character generator RAM directly.
- A customer character pattern can be programmable by mask option.(KS0076B-00 : Standard type)
- Automatic power on reset function.
- It can drive a maximum 80 characters by using the KS0065B or KS0063 externally.
- It is possible to read both Character Generator and Display Data RAM from MPU.

FEATURES

- Wave form: M signal B type
- Internal Memory
 - Character Generator ROM: 8320bits
 - Character Generator RAM: 512 bits
 - Display Data RAM: 80 x 8bits for 80 digits.
- Power supply Voltage; +5V±10%
- Supply voltage for display : 0V(V5)
- CMOS process
- 1/8 duty, 1/11 duty or 1/16 duty: selectable
(1/8 duty; 5x7 dots format 1 line, 1/11 duty; 5x10 dots format 1 line, 1/16 duty; 5x7 dots format 2 line)
- 80 QFP or bare chip available .

80 QFP

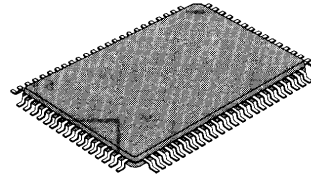

KS0076B 16COM/40SEG DRIVER & CONTROLLER FOR DOT MATRIX LCD

BLOCK DIAGRAM

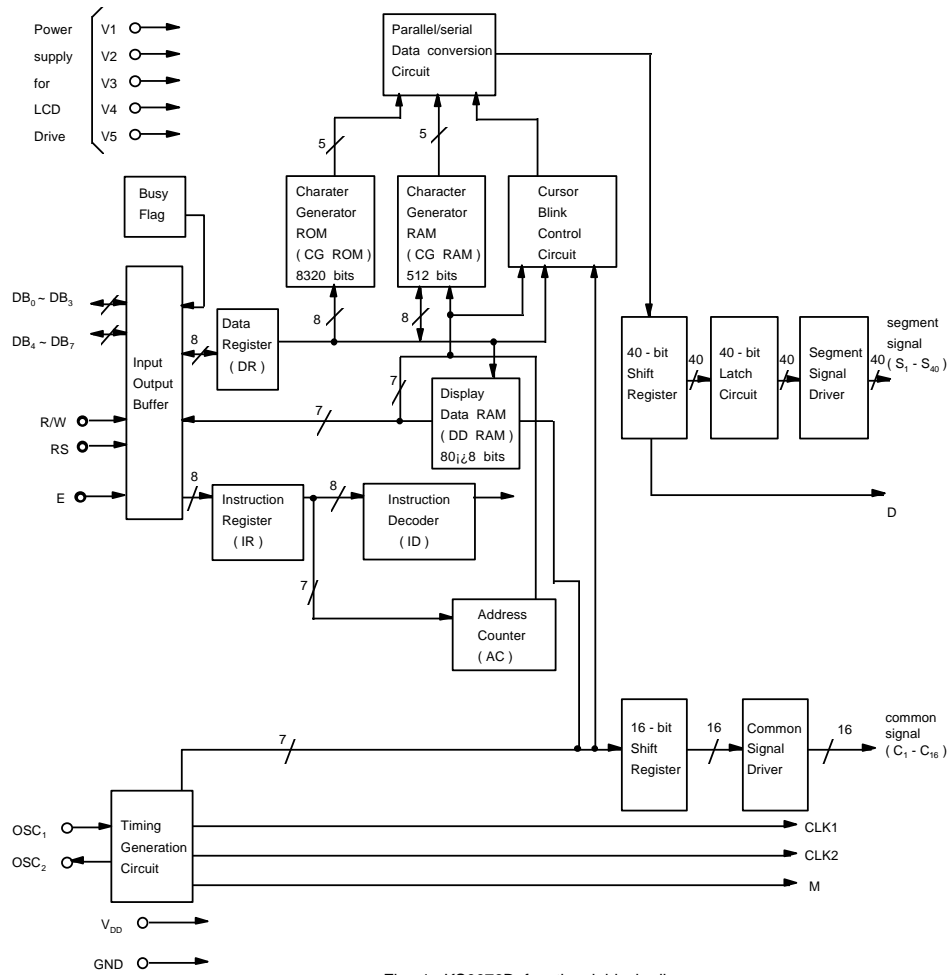

Fig. 1. KS0076B functional block diagram.



KS0076B 16COM/40SEG DRIVER & CONTROLLER FOR DOT MATRIX LCD

PIN CONFIGURATION

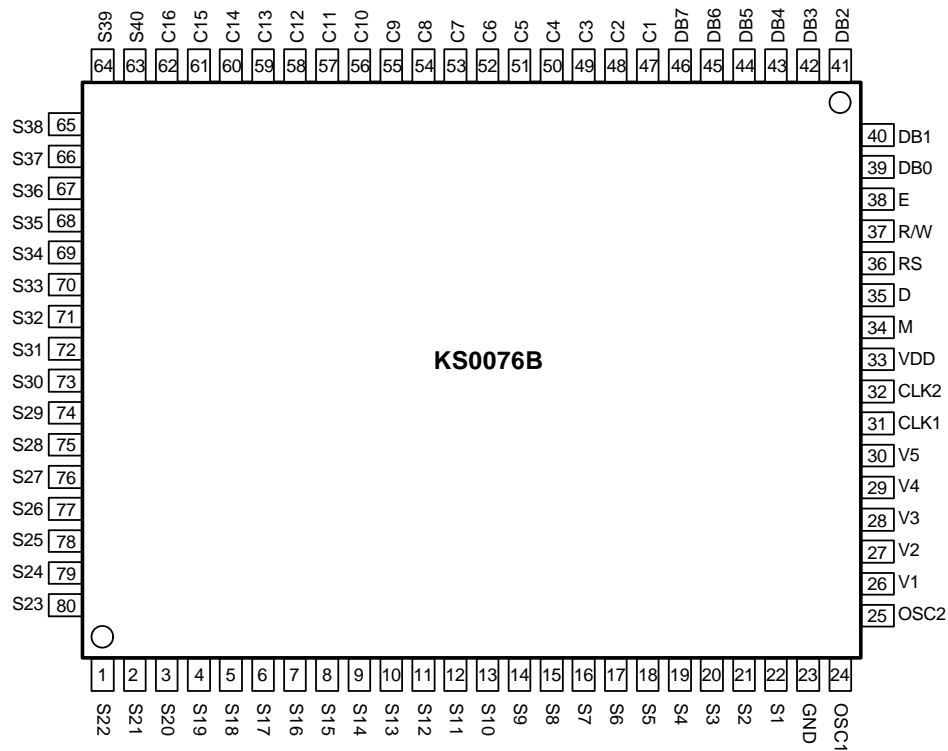

Fig. 2. 80 QFP Top View



KS0076B 16COM/40SEG DRIVER & CONTROLLER FOR DOT MATRIX LCD

PIN DESCRIPTION

PIN (NO)	INPUT/OUTPUT	NAME	DESCRIPTION	INTERFACE				
V _{DD} (33)	Power	Operating Voltage	for logical circuit (5V±10%)	Power supply				
V _{SS} (GND) (23)			0V (GND)					
V ₁ -V ₅ (26-30)		Supply Voltage	Bias voltage level fro LCD driving					
S ₁ -S ₄₀ (22-1, 80-63)	Output	Segment output	Segment signal output for LCD driving	LCD				
C ₁ -C ₁₆ (47-62)	Output	Common output	Common signal output for LCD driving	LCD				
OSC1, OSC2 (24, 25)	Input (OSC1) Output (OSC2)	Oscillator	Both pin connected to Rf resistor or ceramic resonator for internal oscillator circuit. In case of external frequency use only, the frequency is input to OSC1 terminal.	Resistor or Ceramic Resonator				
CLK1 (31)	Output	Data latch Cock	Clock output terminal for the serially transferred data to be latched to the driver.	KS0065B or KS0063				
CLK2 (32)		Data shift clock	Clock output terminal used when D terminal data output shifts the inside of the driver.					
M (34)		Alternated signal for LCD driver output	The alternating signal to convert LCD drive waveform to AC					
D (35)		Display data interface	Character pattern data, which is corresponding to each common signal, is supplied to driver serially. <table border="1" style="margin-left: 20px;"> <tr> <td>High</td> <td>Selection</td> </tr> <tr> <td>Low</td> <td>Non selection</td> </tr> </table>		High	Selection	Low	Non selection
High	Selection							
Low	Non selection							
E (38)	Input	Enable	Start enable signal to read or write the data	MPU				
R/W (37)		Read/Write	R/W signal input is used to select the read/write mode <table border="1" style="margin-left: 20px;"> <tr> <td>High</td> <td>Read mode</td> </tr> <tr> <td>Low</td> <td>Write Mode</td> </tr> </table>		High	Read mode	Low	Write Mode
High		Read mode						
Low	Write Mode							
RS (36)	Register select	Register selection input <table border="1" style="margin-left: 20px;"> <tr> <td>High</td> <td>Data register (for read and write)</td> </tr> <tr> <td>Low</td> <td>Instruction register (for write), Busy flag, address counter (for read)</td> </tr> </table>	High	Data register (for read and write)	Low	Instruction register (for write), Busy flag, address counter (for read)		
High	Data register (for read and write)							
Low	Instruction register (for write), Busy flag, address counter (for read)							
DB ₀ -DB ₇ (39-46)	Input / Output	Data interface	Used for data transfer between the MPU and KS0076B. These terminals are for data bus with bidirectional three-state. Initial 4 bit (DB ₀ -DB ₃) are not used during 4-bit operation (DB ₇ can be used as a busy flag)	MPU				



KS0076B 16COM/40SEG DRIVER & CONTROLLER FOR DOT MATRIX LCD

Internal logic of input/output terminal

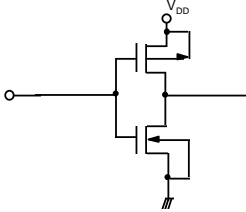
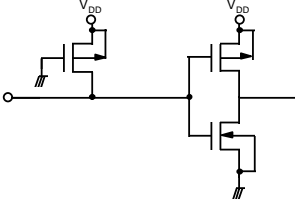
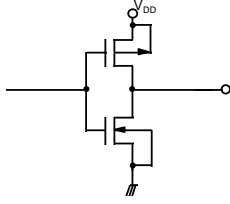
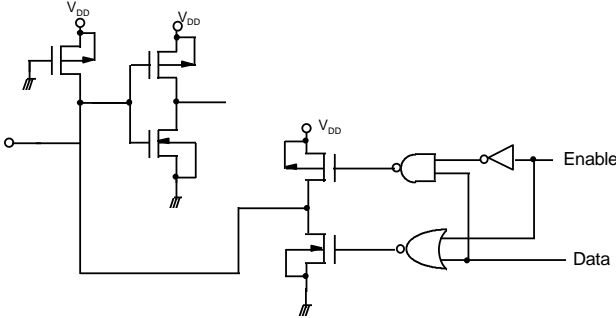
Input/output	Logic diagram		Applicable pin
Input	No Pull up		E
	with pull up		RS, R/W
Output			CLK1, CLK2 M,D
Input Output			DB ₀ - DB ₇



KS0076B 16COM/40SEG DRIVER & CONTROLLER FOR DOT MATRIX LCD

MAXIMUM ABSOLUTE LIMIT (Ta=25°C)

Characteristic	Symbol	Value	Unit
Operating Voltage	V _{DD}	-0.3~+7.0	V
Driver Supply Voltage	V _{LCD}	-0.3~V _{DD} +0.3	V
Input Voltage	V _{IN}	-0.3 ~ V _{DD} +0.3	V
Power Dissipation	P _D	500	mW
Operating Temperature	T _{OPR}	-20~+75	°C
Storage Temperature	T _{STG}	-55~+125	°C

* Voltage greater than above may damage to the circuit (V_{DD}≥V₁≥V₂≥V₃≥V₄≥V₅)

ELECTRICAL CHARACTERISTICS

DC Characteristics (V_{DD}= +5V±10%, V_{SS}=0V, Ta=-20°C ~+75°C)

Characteristic	Symbol	Test condition	Min	Typ	Max	Unit	Applicable Pin		
Operating Voltage	V _{DD}	-	4.5	-	5.5	V			
Operating Current (*1)	I _{DD1}	Ceramic resonator fosc=250KHz	-	0.55	0.8	mA			
	I _{DD2}	Resistor oscillation external clock operation fosc=270KHz	-	0.35	0.6				
Input Voltage 1	High	V _{IH1}	-	2.2	-	V _{DD}	E, OB ₀ -DB ₇ , R/W, RS		
	Low	V _{IL1}	-	-0.3	-			0.6	
Input Voltage 2	High	V _{IH2}	-	V _{DD} -1.0	-	V _{DD}	OSC1		
	Low	V _{IL2}	-	-0.2	-			1.0	
Output Voltage 1	High	V _{OH1}	I _{OH} =-0.205mA	2.4	-	V	DB ₀ -DB ₇		
	Low	V _{OL1}	I _{OL} =1.2mA	-	-			0.4	
Output Voltage 2	High	V _{OH2}	I _O =40μA	0.9V _{DD}	-	V	CLK1, CLK2, M D		
	Low	V _{OL2}	I _O =40μA	-	-			0.1V _{DD}	
Voltage Drop (*2)	COM	V _{dCOM}	I _O =±0.1mA	-	-	1	C1-C16		
	SEG	V _{dSEG}		-	-	1	S1-S40		
Input Leakage Current	I _{LKG}	V _{IN} =0 or V _{DD}	-1	-	1	μA	E		
Input Low Current	I _{IL}	V _{DD} =5V (test pull up R)	-50	-125	-250		RS, R/W, DB ₀ -DB ₇		
External Clock	Frequency (*3)	f _{EC}	-	125	250	350	KHz	OSC1	
	Duty	duty	-	45	50	55			%
	Rise Time	t _R	-	-	-	0.2			μs
	Fall Time	t _F	-	-	-	0.2			μs
Internal Clock Frequency (*3)	f _{OSC1}	Rf=91KΩ±2%	190	270	350	KHz	OSC1, OSC2		
Ceramic Resonator Oscillation Frequency (*3)	f _{OSC2}	-	245	250	255				
LCD Driving Voltage (*4)	V _{LCD1}	V _{DD} -V ₅	1/5 bias	4.6	-	V _{DD}	V	V ₁ ~ V ₅	
	V _{LCD2}		1/4 bias	3.0	-	V _{DD}			

Note: *1) Applies to the current value flow in terminal V_{DD} when power is input as follows; V_{DD}=5V, GND=0V, V₁ = 3.75V, V₂ = 2.5V, V₃ = 2.5V, V₄ = 1.25V and V₅ = 0V.

*2) Applied to the voltage drop occurring from terminals V_{DD}, V₁, V₄ and V₅ to each common terminal (C1-C16) when 0.1mA is flow in or out to and from all COM and SEG terminals, and also to voltage drop occurring from terminals V_{DD}, V₂, V₃ and V₅ to each SEG terminal S1-S40. When the output level is at V_{DD}, V₁ or V₂ level, 0.1 mA is flow out, while 0.1 mA flow in when the output level is at V₃, V₄, or V₅ level. This occurs when 5V is input to V_{DD}, V₁ and V₃ or to V₂, V₄, and V₅ respectively.



KS0076B 16COM/40SEG DRIVER & CONTROLLER FOR DOT MATRIX LCD

*3) Oscillator circuit

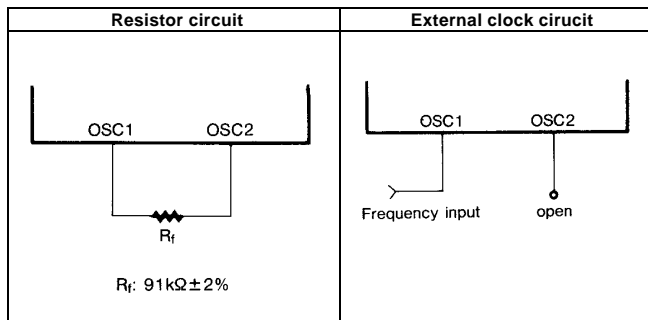

*4) Input the voltage listed in the table below to V_1 - V_5

Power	Duty	1/8, 1/11	1/16
	Bias	1/4	1/5
V_1		$V_{DD} - V_{LCD}/4$	$V_{DD} - V_{LCD}/5$
V_2		$V_{DD} - V_{LCD}/2$	$V_{DD} - 2V_{LCD}/5$
V_3		$V_{DD} - V_{LCD}/2$	$V_{DD} - 3V_{LCD}/5$
V_4		$V_{DD} - 3V_{LCD}/4$	$V_{DD} - 4V_{LCD}/5$
V_5		$V_{DD} - V_{LCD}$	$V_{DD} - V_{LCD}$

* V_{LCD} is the LCD driving voltage, refer to the initial set of the instruction code.



KS0076B 16COM/40SEG DRIVER & CONTROLLER FOR DOT MATRIX LCD

AC Characteristics ($V_{DD}=5V\pm 10\%$, $V_{SS}=0V$ $T_a=-20 \sim +75^\circ C$)

(1) Write mode (Writing data from Micom to KS0076B)

Characteristic	Symbol	Min	Typ	Max	Unit	Test pin
E Cycle Time	t_c	500	-	-	ns	E
E Rise Time	t_R	-	-	25	ns	E
E Fall Time	t_F	-	-	25	ns	E
E Pulse Width (High, Low)	t_w	220	-	-	ns	E
R/W And RS Set-Up Time	t_{SU1}	40	-	-	ns	R/W, RS
R/W And RS Hold Time	t_{H1}	10	-	-	ns	R/W, RS
Data Set-Up Time	t_{SU2}	60	-	-	ns	DB ₀ ~ DB ₇
Data Hold Time	t_{H2}	10	-	-	ns	DB ₀ ~ DB ₇

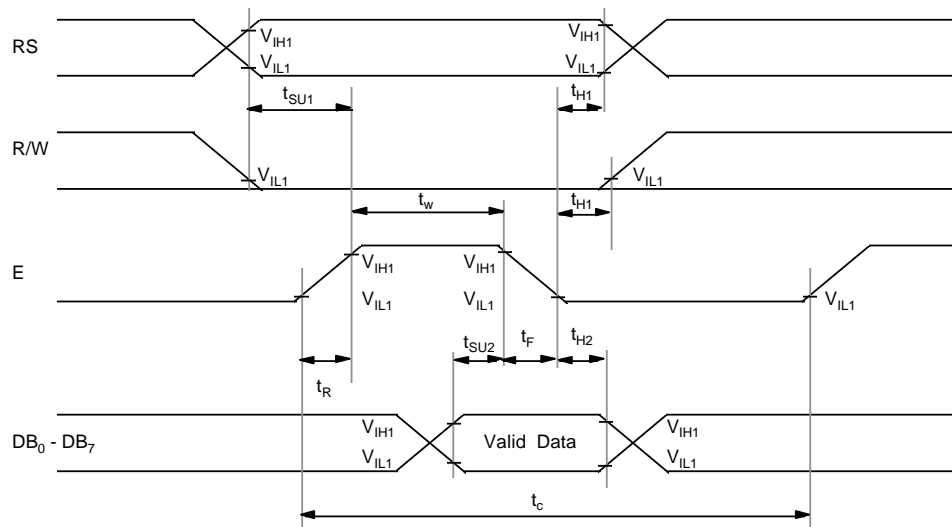

(2) Read mode (Reading data from KS0076B to Micom)

Characteristic	Symbol	Min	Typ	Max	Unit	Test pin
E Cycle Time	t_c	500	-	-	ns	E
E Rise Time	t_R	-	-	25	ns	E
E Fall Time	t_F	-	-	25	ns	E
E Pulse Width (High, Low)	t_w	220	-	-	ns	E
R/W And RS Set-Up Time	t_{SU}	40	-	-	ns	R/W, RS
R/W And RS Hold Time	t_H	10	-	-	ns	R/W, RS
Data Output Delay Time	t_D	-	-	120	ns	DB ₀ ~ DB ₇
Data Hold Time	t_{DH}	20	-	-	ns	DB ₀ ~ DB ₇



KS0076B 16COM/40SEG DRIVER & CONTROLLER FOR DOT MATRIX LCD

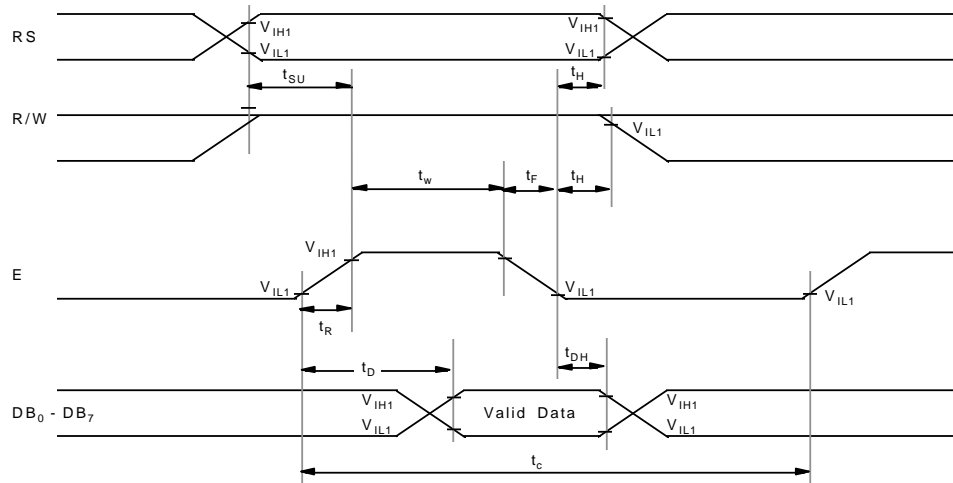

(3) Interface mode with KS0065B, KS0063

Characteristic	Symbol	Min	Typ	Max	Unit	Test pin
Clock Pulse Width High	t_{WCKH}	800	-	-	ns	CLK
Clock Pulse Width Low	t_{WCKL}	800	-	-	ns	CLK
Data Set-Up Time	t_{SU}	300	-	-	ns	D
Data Hold Time	t_{DH}	300	-	-	ns	D
Clock Set-Up Time	t_{CSU}	500	-	-	ns	CLK
M Delay Time	t_{DM}	-1000	-	1000	ns	M

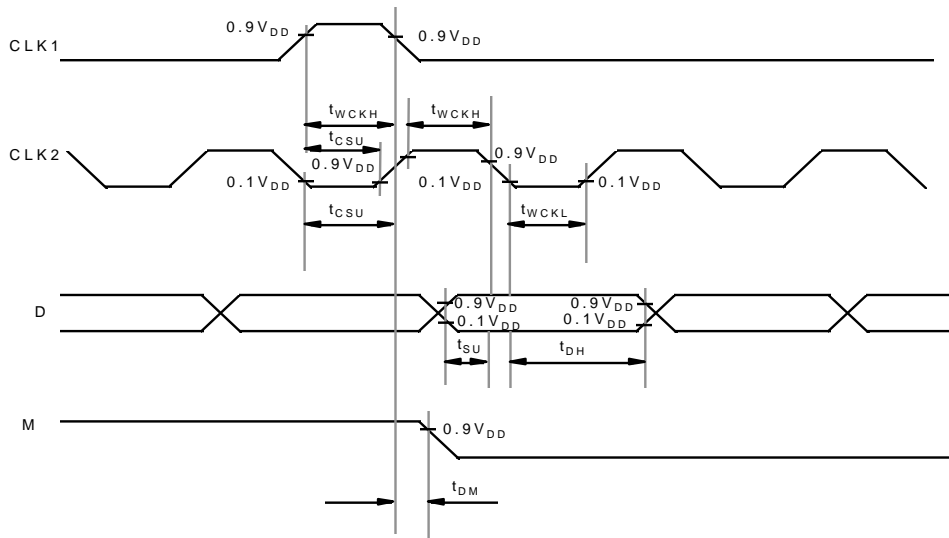

KS0076B 16COM/40SEG DRIVER & CONTROLLER FOR DOT MATRIX LCD

CONTROL and DISPLAY COMMAND

Command	RS	R/W	DB ₇	DB ₆	DB ₅	DB ₄	DB ₃	DB ₂	DB ₁	DB ₀	Excution time (fosc=250KHz)	Remark																		
DISPLAY CLEAR	L	L	L	L	L	L	L	L	L	H	1.64ms																			
RETURN HOME	L	L	L	L	L	L	L	L	H	X	1.64ms	cursor move to first digit																		
ENTRY MODE SET	L	L	L	L	L	L	L	H	I/D	SH	40μs	<ul style="list-style-type: none"> I/D: set cursor move direction <table border="1"> <tr><td>I/D</td><td>H</td><td>Increase</td></tr> <tr><td>I/D</td><td>L</td><td>Decrease</td></tr> </table> SH: Specifies shift of display, display is shifted <table border="1"> <tr><td>SH</td><td>H</td><td>display is shifted</td></tr> <tr><td>SH</td><td>L</td><td>display is not shifted</td></tr> </table> 	I/D	H	Increase	I/D	L	Decrease	SH	H	display is shifted	SH	L	display is not shifted						
I/D	H	Increase																												
I/D	L	Decrease																												
SH	H	display is shifted																												
SH	L	display is not shifted																												
DISPLAY ON/OFF	L	L	L	L	L	L	H	D	C	B	40μs	<ul style="list-style-type: none"> Display <table border="1"> <tr><td>D</td><td>H</td><td>Display on</td></tr> <tr><td>D</td><td>L</td><td>Display off</td></tr> </table> Cursor <table border="1"> <tr><td>C</td><td>H</td><td>Cursor on</td></tr> <tr><td>C</td><td>L</td><td>Cursor off</td></tr> </table> Blinking <table border="1"> <tr><td>B</td><td>H</td><td>Blinking on</td></tr> <tr><td>B</td><td>L</td><td>Blinking off</td></tr> </table> 	D	H	Display on	D	L	Display off	C	H	Cursor on	C	L	Cursor off	B	H	Blinking on	B	L	Blinking off
D	H	Display on																												
D	L	Display off																												
C	H	Cursor on																												
C	L	Cursor off																												
B	H	Blinking on																												
B	L	Blinking off																												
SHIFT	L	L	L	L	L	H	S/C	R/L	X	X	40μs	<table border="1"> <tr><td>SC</td><td>H</td><td>Display shift</td></tr> <tr><td>SC</td><td>L</td><td>Cursor move</td></tr> </table> <table border="1"> <tr><td>R/L</td><td>H</td><td>Right shift</td></tr> <tr><td>R/L</td><td>L</td><td>Left shift</td></tr> </table>	SC	H	Display shift	SC	L	Cursor move	R/L	H	Right shift	R/L	L	Left shift						
SC	H	Display shift																												
SC	L	Cursor move																												
R/L	H	Right shift																												
R/L	L	Left shift																												
SET FUNCTION	L	L	L	L	H	DL	N	F	X	X	40μs	<table border="1"> <tr><td>DL</td><td>H</td><td>8 bits interface</td></tr> <tr><td>DL</td><td>L</td><td>4 bits interface</td></tr> </table> <table border="1"> <tr><td>N</td><td>H</td><td>2 line display</td></tr> <tr><td>N</td><td>L</td><td>1 line display</td></tr> </table> <table border="1"> <tr><td>F</td><td>H</td><td>5x10 dots</td></tr> <tr><td>F</td><td>L</td><td>5x7 dots</td></tr> </table>	DL	H	8 bits interface	DL	L	4 bits interface	N	H	2 line display	N	L	1 line display	F	H	5x10 dots	F	L	5x7 dots
DL	H	8 bits interface																												
DL	L	4 bits interface																												
N	H	2 line display																												
N	L	1 line display																												
F	H	5x10 dots																												
F	L	5x7 dots																												

Table 1.



CONTROL and DISPLAY COMMAND (continued)

Command	RS	R/W	DB ₇	DB ₆	DB ₅	DB ₄	DB ₃	DB ₂	DB ₁	DB ₀	Excution time (fosc=250KHz)	Remark					
SET CG RAM ADDRESS	L	L	L	H	CG RAM address (corresponds to cursor address)						40μs	CG RAM Data is sent and received after this setting					
SET DD RAM ADDRESS	L	L	H	DD RAM address						40μs	DD RAM Data is sent and received after this setting						
READ BUSY FLAG & ADDRESS	L	H	BF	Address Counter used for Both DD & CG RAM address						0μs	<table border="1"> <tr> <td>BF</td> <td>H</td> <td>Busy</td> </tr> <tr> <td></td> <td>L</td> <td>Ready</td> </tr> </table> <p>- Reads BF indication internal operating is being performed. - reads address counter contents</p>	BF	H	Busy		L	Ready
BF	H	Busy															
	L	Ready															
WRITE DATA	H	L	Read Data						46μs	Write data into DD or CGRAM							
READ DATA	H	H	Write Data						46μs	Read data from DD or CGRAM							

X: don't care

Table 1



KS0076B 16COM/40SEG DRIVER & CONTROLLER FOR DOT MATRIX LCD

APPLICATION INFORMATION ACCORDING TO LCD PANEL

1) LCD Panel: 8 character x 1 line character format; 5x7 dots + 1 cursor line (1/4 bias, 1/8 duty)

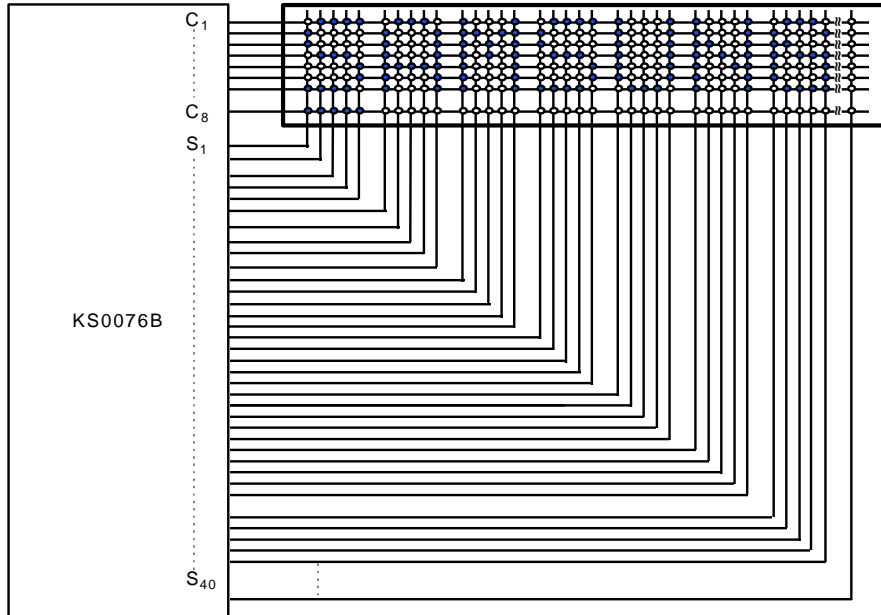

2) LCD Panel: 8 character x 1 line character format; 5x10 dots + 1 cursor line (1/4 bias, 1/11 duty)

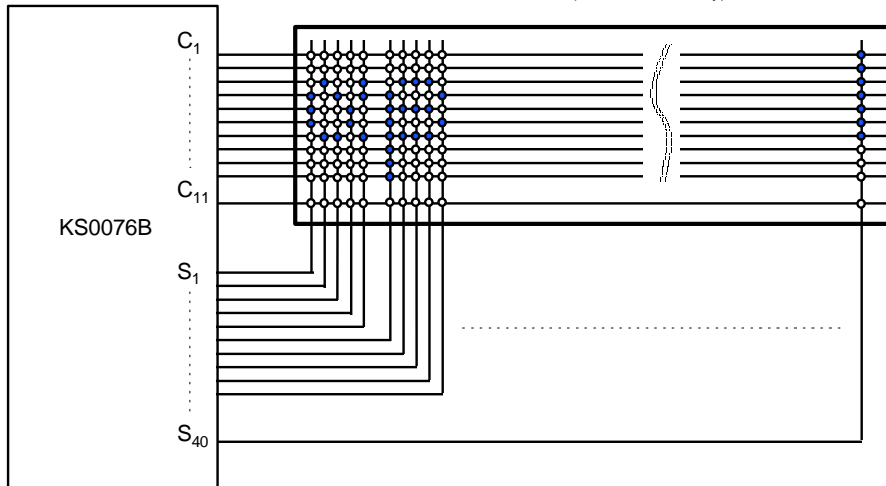

KS0076B 16COM/40SEG DRIVER & CONTROLLER FOR DOT MATRIX LCD

3) LCD Panel : 8 character x 2 line character format; 5 x 7 dots + 1 cursor line (1/5 bias, 1/16 duty)

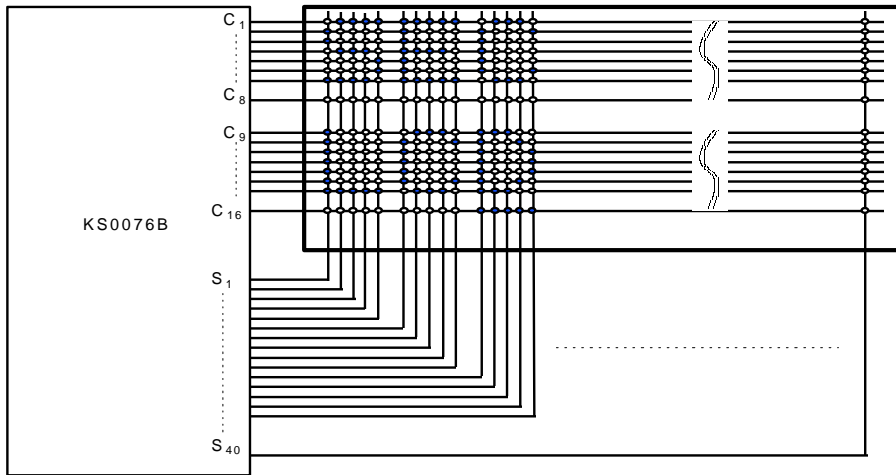

4) LCD Panel : 16 character x 1 line Character format; 5x7 dots + 1 cursor line (1/5 bias, 1/16 duty)

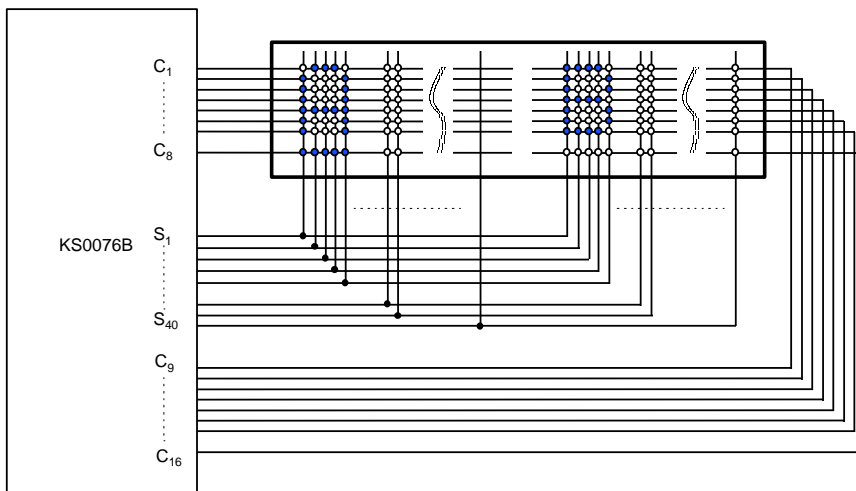

KS0076B 16COM/40SEG DRIVER & CONTROLLER FOR DOT MATRIX LCD

5) LCD Panel : 4character x 2 line character ; 5x 7 dots + 1 cursor line (1/4 bias, 1/8 duty)

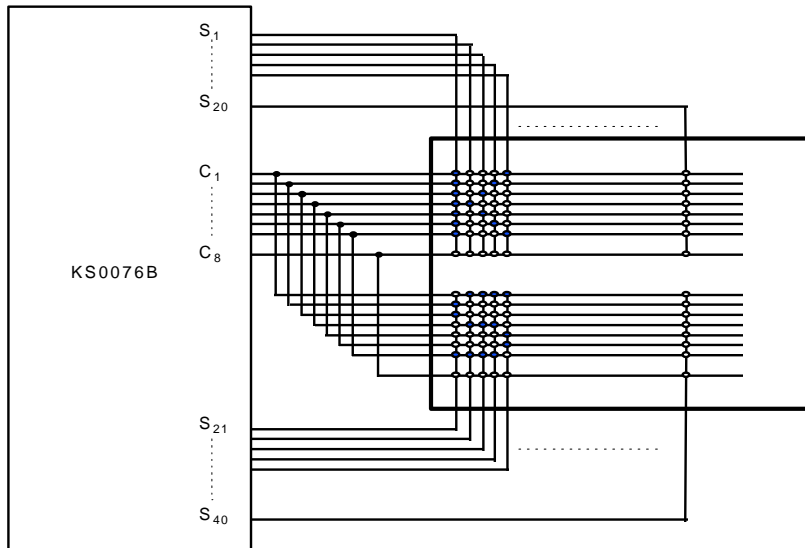

DIVIDE CIRCUIT

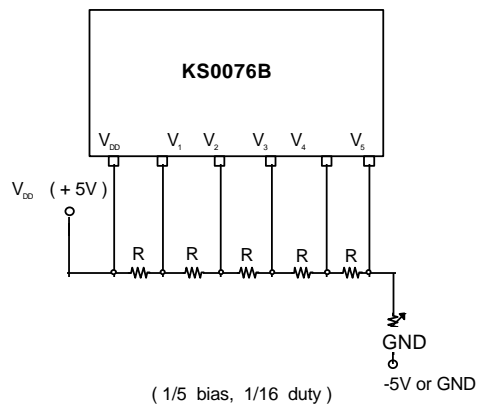
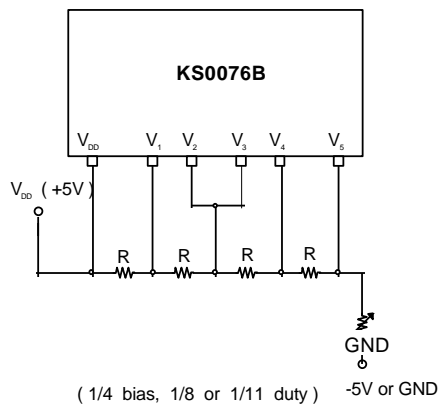

KS0076B 16COM/40SEG DRIVER & CONTROLLER FOR DOT MATRIX LCD

APPLICATION CIRCUIT

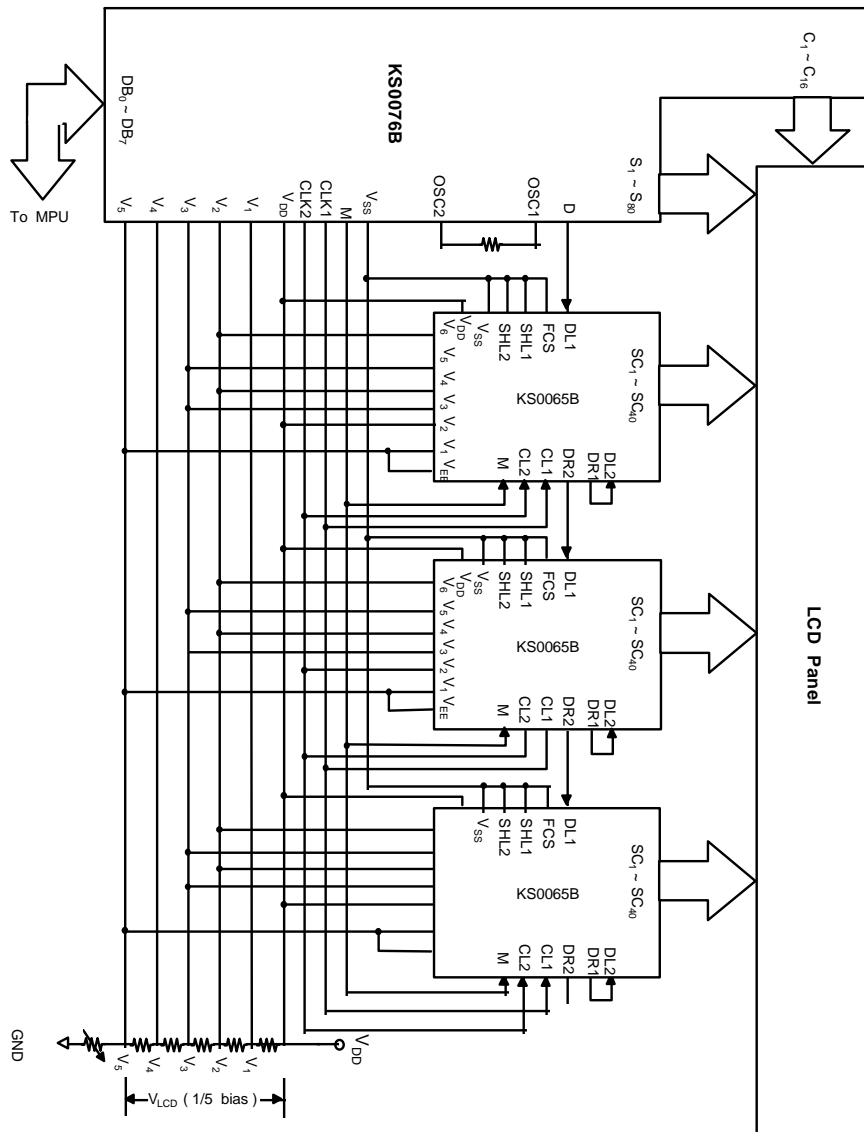

When KS0065B is externally connected to the KS0076B, you can increase the number of display digits up to 80 characters.



KS0076B 16COM/40SEG DRIVER & CONTROLLER FOR DOT MATRIX LCD

PAD DIAGRAM

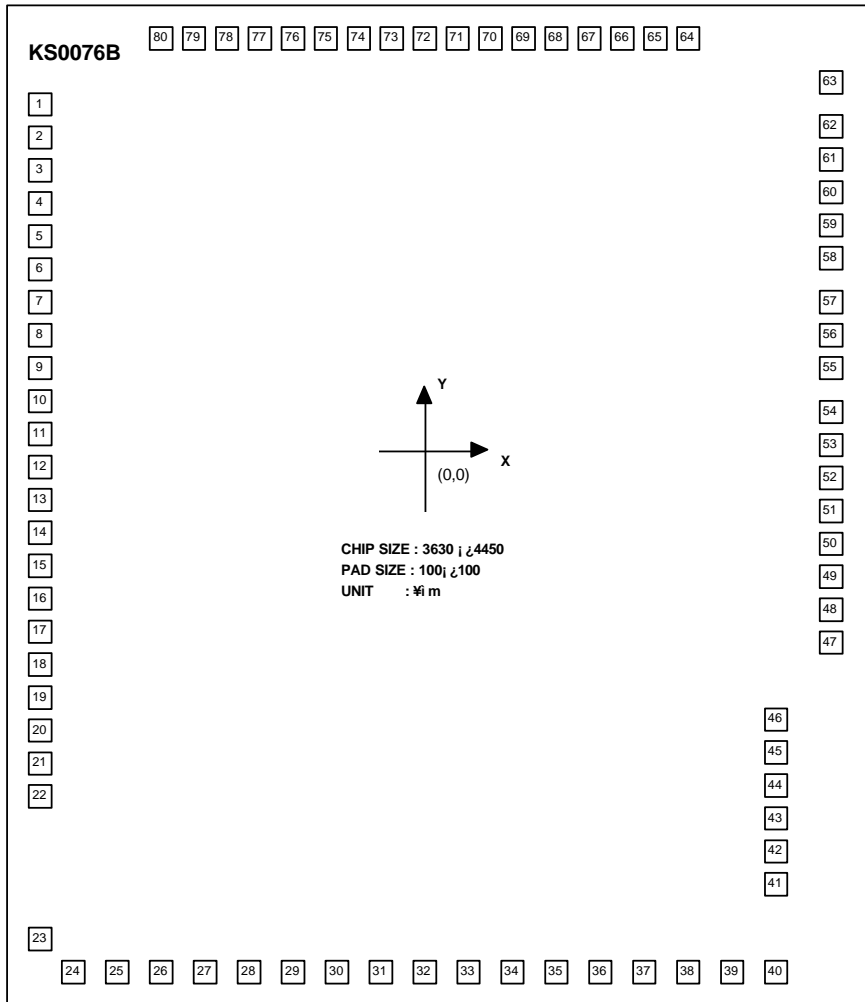

* "KS0076B" Marking : easy to find the PAD No.1



KS0076B 16COM/40SEG DRIVER & CONTROLLER FOR DOT MATRIX LCD

PAD LOCATION

UNIT (μm)

NUMBER	PAD NAME	COORDINATE		PAD NUMBER	PAD NAME	COORDINATE		PAD NUMBER	PAD NAME	COORDINATE	
		X	Y			X	Y			X	Y
1	S22	-1630	1816.5	28	V3	-673.5	-1911.5	55	C9	1630	717.5
2	S21	-1630	1676.5	29	V4	-489.5	-1911.5	56	C10	1630	857.5
3	S20	-1630	1536.5	30	V5	-305.5	-1911.5	57	C11	1630	997.5
4	S19	-1630	1396.5	31	CLK1	-121.5	-1911.5	58	C12	1630	1166
5	S18	-1630	1256.5	32	CLK2	62.5	-1911.5	59	C13	1630	1306
6	S17	-1630	1116.5	33	VDD	240.5	-1911.5	60	C14	1630	1446
7	S16	-1630	976.5	34	M	409.5	-1911.5	61	C15	1630	1586
8	S15	-1630	836.5	35	D	593.5	-1911.5	62	C16	1630	1276
9	S14	-1630	696.5	36	RS	777.5	-1911.5	63	S40	1630	1918
10	S13	-1630	556.5	37	R/W	961.5	-1911.5	64	S39	1104.5	2040
11	S12	-1630	416.5	38	E	1145.5	-1911.5	65	S38	964.5	2040
12	S11	-1630	276.5	39	DB0	1329.5	-1911.5	66	S37	824.5	2040
13	S10	-1630	136.5	40	DB1	1513.5	-1911.5	67	S36	684.5	2040
14	S9	-1630	-3.5	41	DB2	1501.5	-1573	68	S35	544.5	2040
15	S8	-1630	-143.5	42	DB3	1501.5	-1389	69	S34	404.5	2040
16	S7	-1630	-283.5	43	DB4	1501.5	-1205	70	S33	264.5	2040
17	S6	-1630	-423.5	44	DB5	1501.5	-1021	71	S32	124.5	2040
18	S5	-1630	-563.5	45	DB6	1501.5	-837	72	S31	-15.5	2040
19	S4	-1630	-703.5	46	DB7	1501.5	-653	73	S30	-155.5	2040
20	S3	-1630	-843.5	47	C1	1630	-452	74	S29	-295.5	2040
21	S2	-1630	-983.5	48	C2	1630	-312	75	S28	-435.5	2040
22	S1	-1630	-1123.5	49	C3	1630	-172	76	S27	-575.5	2040
23	GND	-1630	-1722.5	50	C4	1630	-32	77	S26	-715.5	2040
24	OSC1	-1401.5	-1911.5	51	C5	1630	108	78	S25	-855.5	2040
25	OSC2	-1217.5	-1911.5	52	C6	1630	248	79	S24	-995.5	2040
26	V1	-1041.5	-1911.5	53	C7	1630	388	80	S23	-1135.5	2040
27	V2	-857.5	-1911.5	54	C8	1630	528				

Standard Character Pattern (KS0076B-00)

