

Model(型號): **ROTARY POTENTIOMETER-----R12C12AB1**

► Download PDF file



**Features:(特點):**

Excellent operatonal feeling

**Applications(作用):**

Ideal for volume,tone and balance control of car audio equipment.

**Dimensions(規格圖):**

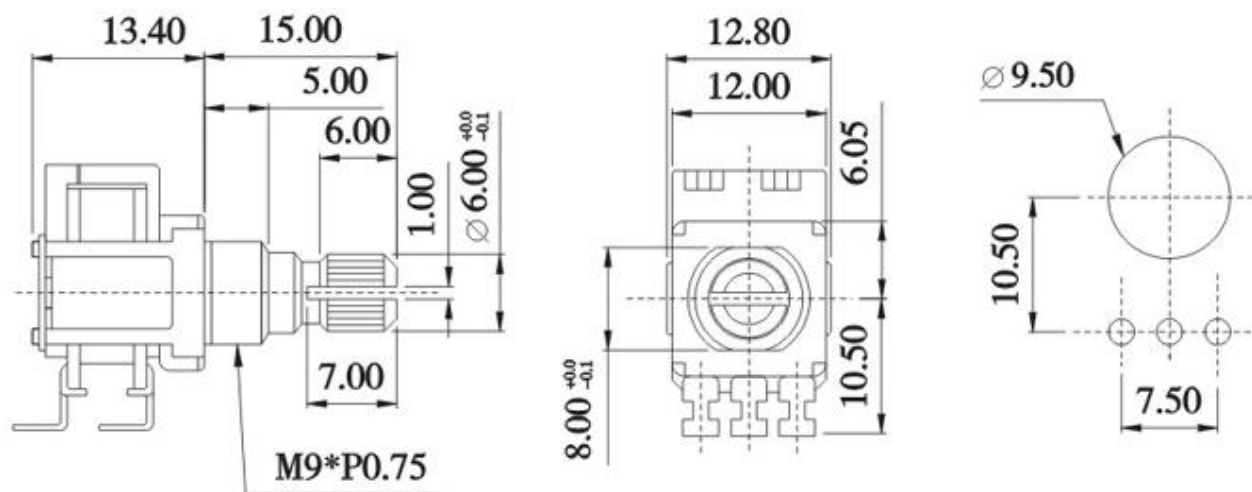

**Specifications(規格)**

**Electrical Characteristics [ 電氣性能 ]**

Total resistance [ 全阻抗值 ]	40Ω . 80MΩ
Total resistance tolerance [ 全阻抗值容許差 ]	±20%
Ratings power(w) [ 額定功率 ]	2.5W
Residual resistance [ 殘留阻值 ]	1KΩMax.
Sliding noise [ 滑動雜音 ]	Single unit:47mV Max. Dual unit:100mV Max.
Withstanding voltage [ 耐電壓 ]	1 minute at AC 250V
Insulation resistance [ 絕緣阻抗 ]	100MΩ Min. at DC 500V.
Max. operating voltage [ 最高使用電壓 ]	DC 6.3V

**Mechanical Characteristics [ 機械性能 ]**

Operation torque [ 回轉力矩 ]	20~200gf . cm
Rotation stopper strength [ 止動強度 ]	4.0Kgf . cm Min.
Total rotational angle [ 回轉角度 ]	180±5°
position of click[ 掣子位置 ]	150° ±5°
Center decent force [ 掣子脫出力矩 ]	50~300gf.cm

**Endurance Characteristics [ 耐久性能 ]**

Rotational life [ 回轉壽命 ]	More than10,000 cycles
--------------------------	------------------------