Step-up DC/DC converter for White LED Backlight

NO.EA-166-070905

OUTLINE

The R1218x Series are PWM control type step-up DC/DC converter ICs with low supply current.

The R1218x is fully dedicated to drive White LED with constant current. Each of these ICs consists of an NMOS FET, an oscillator, a PWM comparator, a voltage reference unit, an error amplifier, an under voltage lockout circuit (UVLO), an over-voltage protection circuit (OVP), and so on.

The R1218x can drive white LEDs with high efficiency with low supply current. A diode is built-in the R1218xxx1A, therefore it is possible to drive up to 4LEDs without an external diode. The R1218xxx2A, an external diode is necessary, however, up to 6 serial LEDs can be driven with the R1218xxx2A.

Constant current can be set with an external resistance value. Dimming control is possible by PWM signal for CE pin. Feedback voltage is 0.2V, therefore power loss by current setting resistance is small and efficiency is good. Maximum duty cycle is internally fixed, Typ. 91%. LEDs can be driven from low voltage. Protection circuits are the current limit of Lx peak current, the over voltage limit of output, and the under voltage lockout function.

Packages are standard SOT-23-6 and very tiny PLP1820-6.

FEATURES

- Operating voltage..... 1.8V to 5.5V
- Built-in 400mA, 1.5Ω, 20V Nch MOSFET (R1218xxx1A)
- Built-in 400mA, 1.5Ω, 29V Nch MOSFET (R1218xxx2A)
- Oscillator Frequency (PWM control)..... 1.2MHz
- Maximum Duty Cycle Typ. 91%
- Feedback Voltage Typ. 0.2V
- UVLO Threshold Voltage Typ. 1.6V (Hysteresis Typ. 0.1V)
- Lx Current limit Protection..... Typ. 700mA
- Over Voltage Protection (OVP) Threshold.... Typ. 9.5V (R1218x021A)
Typ. 14.0V (R1218x031A)
Typ. 18.5V (R1218x041A)
Typ. 23.0V (R1218x052A)
Typ. 27.5V (R1218x062A)
- LED dimming control..... by external PWM signal (Frequency 200Hz to 5kHz) to CE pin
by feedback voltage and filtered PWM signal (high frequency)
- Packages SOT-23-6 or PLP1820-6

APPLICATION

- White LED Backlight for portable equipment

BLOCK DIAGRAMS

R1218xxx1A

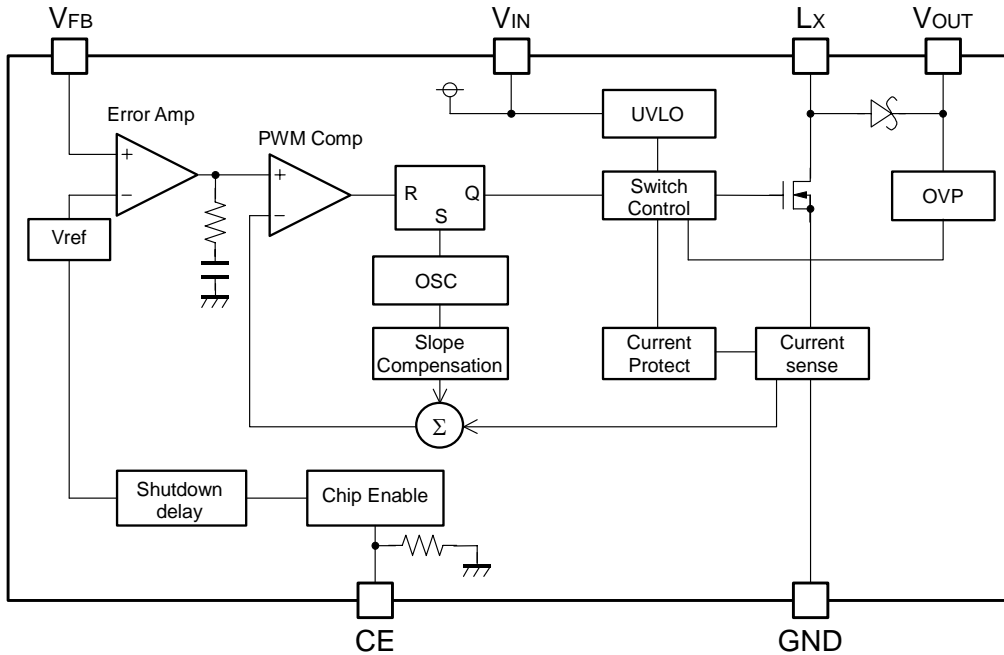

R1218xxx2A

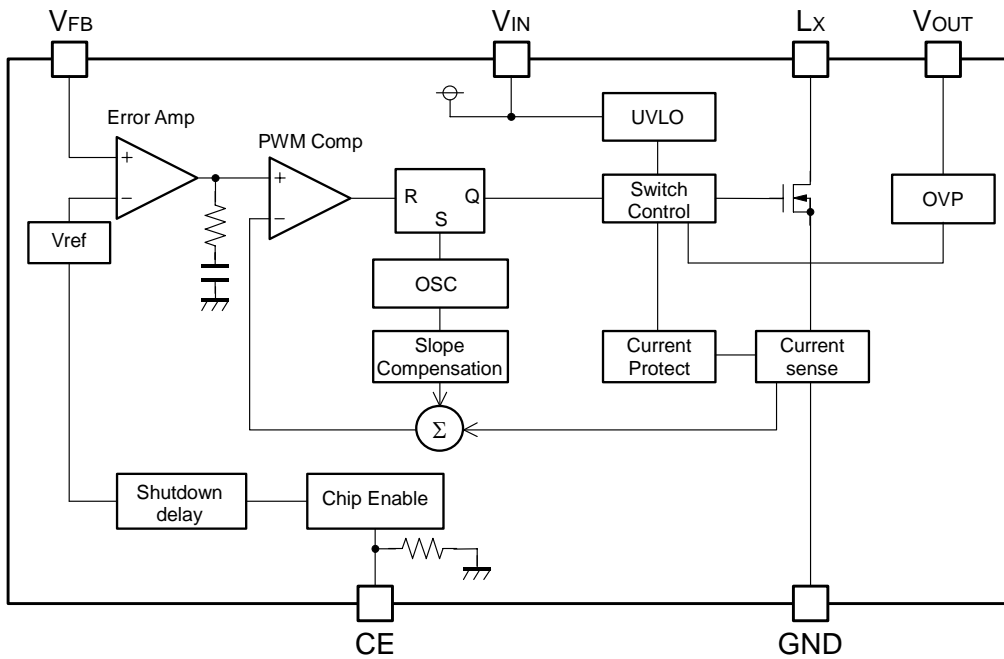

SELECTION GUIDE

The OVP threshold voltage and the package for the ICs can be selected at the user's request.
The selection can be available by designating the part number as shown below;

R1218xxxxx-xx-X ←Part Number
 ↑ ↑ ↑ ↑
 a b c d

Code	Contents
a	Designation of Package Type: N: SOT-23-6 K: PLP1820-6
b	Designation of OVP threshold and with/without of built-in diode 021A: 9.5V with built-in diode 031A: 14.0V with built-in diode 041A: 18.5V with built-in diode 052A: 23.0V without built-in diode 062A: 27.5V without built-in diode
c	Designation of Taping Type: Ex. TR (refer to Taping Specifications; for SOT-23-6 and PLP1820-6)
d	Designation of composition of plating: -F : Lead free plating (SOT-23-6) None : Au plating (PLP1820-6)

PIN CONFIGURATIONS

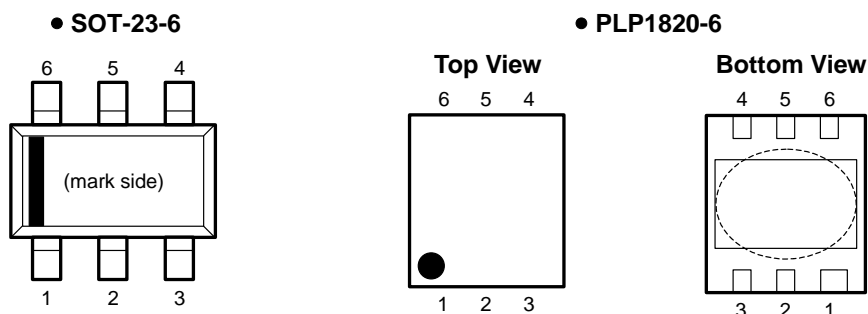

PIN DESCRIPTIONS

• SOT-23-6

Pin No.	Symbol	Description
1	CE	Chip Enable Pin
2	V _{OUT}	Output Pin
3	V _{IN}	Power Supply Input Pin
4	L _X	Switching Pin (Open Drain Output)
5	GND	Ground Pin
6	V _{FB}	Feedback Pin

• PLP1820-6

Pin No.	Symbol	Description
1	CE	Chip Enable Pin
2	V _{FB}	Feedback Pin
3	L _X	Switching Pin (Open Drain Output)
4	GND	Ground Pin
5	V _{IN}	Power Supply Input Pin
6	V _{OUT}	Output Pin

* Tab in the  parts have GND level.
(They are connected to the back side of this IC.)
Do not connect to other wires or land patterns.

ABSOLUTE MAXIMUM RATINGS

(GND=0V)

Symbol	Item	Rating	Unit
V _{IN}	V _{IN} Pin Voltage	6.5	V
V _{CE}	CE Pin Voltage	-0.3 to V _{IN} +0.3	V
V _{FB}	V _{FB} Pin Voltage	-0.3 to V _{IN} +0.3	V
V _{OUT}	V _{OUT} Pin Voltage	R1218xxx1A	-0.3 to 22
		R1218xxx2A	-0.3 to 32
V _{LX}	L _X Pin Voltage	R1218xxx1A	-0.3 to 22
		R1218xxx2A	-0.3 to 32
I _{LX}	L _X Pin Current	800	mA
P _D	Power Dissipation (SOT-23-6) *Note1	420	mW
	Power Dissipation (PLP1820-6) *Note1	880	
T _{opt}	Operating Temperature Range	-40 to 85	°C
T _{stg}	Storage Temperature Range	-55 to 125	°C

*Note1) For Power Dissipation, please refer to PACKAGE INFORMATION to be described.

ELECTRICAL CHARACTERISTICS

● R1218xxxxA

T_{opt}=25°C

Symbol	Item	Conditions	Min.	Typ.	Max.	Unit	
V _{IN}	Operating Input Voltage		1.8		5.5	V	
I _{DD}	Supply Current	V _{IN} =5.5V, V _{FB} =0V, Lx at no load		0.5	1.0	mA	
I _{standby}	Standby Current	V _{IN} =5.5V, V _{CE} =0V		0	3.0	μA	
V _{UVLO1}	UVLO Detector Threshold	V _{IN} falling	1.5	1.6	1.7	V	
V _{UVLO2}	UVLO Released Voltage	V _{IN} rising		V _{UVLO1} +0.1	1.8	V	
V _{CEH}	CE Input Voltage "H"	V _{IN} =5.5V	1.5			V	
V _{CEL}	CE Input Voltage "L"	V _{IN} =1.8V			0.5	V	
R _{CE}	CE Pull Down Resistance	V _{IN} =3.6V	600	1200	2200	kΩ	
tshtdn	CE Shutdown Delay Time	V _{IN} =3.6V		10		ms	
V _{FB}	V _{FB} Voltage	V _{IN} =3.6V	0.19	0.20	0.21	V	
ΔV _{FB} /ΔT _{opt}	V _{FB} Voltage Temperature Coefficient	V _{IN} =3.6V, -40°C ≤ T _{opt} ≤ 85°C		±150		ppm/°C	
I _{FB}	V _{FB} Input Current	V _{IN} =5.5V, V _{FB} =0V or 5.5V	-0.1		0.1	μA	
R _{ON}	Switch On Resistance	V _{IN} =3.6V, I _{SW} =100mA		1.5		Ω	
I _{LXleak}	Switch Leakage Current	R1218xxx1A V _{LX} =20V		0	3.0	μA	
		R1218xxx2A V _{LX} =29V		0	3.0	μA	
I _{LXlim}	Switch Current Limit	V _{IN} =3.6V	400	700	1000	mA	
V _f	Diode Forward Voltage	R1218xxx1A I _{DIODE} =100mA		0.8		V	
I _{DIODEleak}	Diode Leakage Current	R1218xxx1A V _{OUT} =20V, V _{LX} =0V		10		μA	
f _{osc}	Oscillator Frequency	V _{IN} =3.6V, V _{OUT} =V _{FB} =0V	1.0	1.2	1.4	MHz	
Maxduty	Maximum Duty Cycle	V _{IN} =3.6V, V _{OUT} =V _{FB} =0V	86	91		%	
V _{OVP1}	OVP Detector Threshold	V _{IN} =3.6V, V _{OUT} rising	R1218x021A	8.5	9.5	10.5	V
			R1218x031A	13.0	14.0	15.0	
			R1218x041A	17.0	18.5	20.0	
			R1218x052A	21.5	23.0	24.5	
			R1218x062A	26.0	27.5	29.0	
V _{OVP2}	OVP Released Voltage	V _{IN} =3.6V, V _{OUT} falling	R1218x021A		V _{OVP1} -0.5		V
			R1218x031A		V _{OVP1} -0.75		
			R1218x041A		V _{OVP1} -1.0		
			R1218x052A		V _{OVP1} -1.25		
			R1218x062A		V _{OVP1} -1.5		

TYPICAL APPLICATIONS

R1218x041A

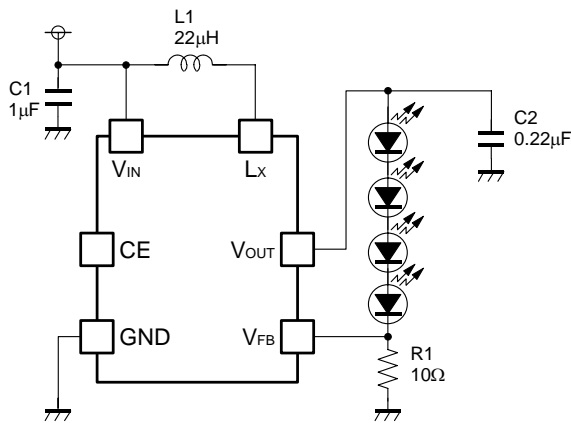

R1218x062A

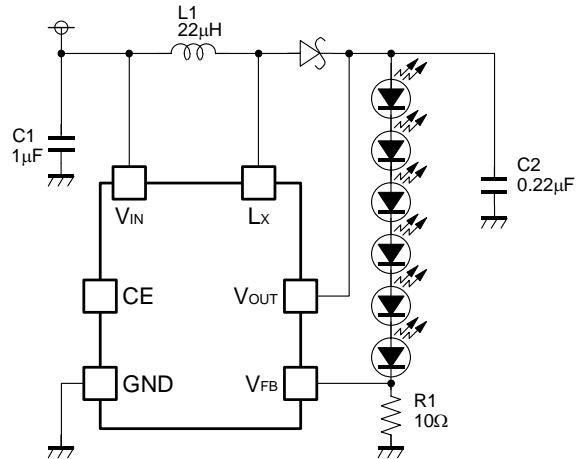

• LED Current setting

LED current can be set with feedback resistor(R1)

$$I_{LED} = 0.2 / R1$$

• LED Dimming Control, Softstart

(1) LED dimming control by PWM signal to CE pin

LED dimming control is possible by forcing PWM signal to CE pin.

When the power-on or start up with CE pin, softstart function works, however, after that, if the CE pin is set as "L" and set CE pin "H" again during the shutdown delay time, softstart function is disabled and starts up fast to normal mode, therefore 200Hz to 5kHz PWM signal is standard. By the CE pin input, LED turns on and off. Average LED current varies depending on the duty cycle of CE input. Too high frequency PWM signal is not effective because of its delay.

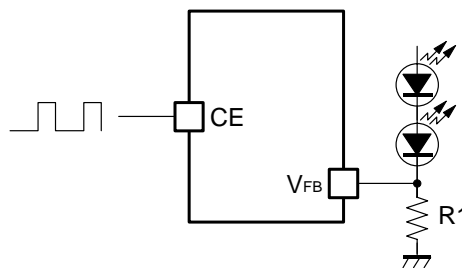

Dimming controle by CE pin input

(2) Dimming control by DC voltage

LED dimming control is also possible by using the DC voltage to V_{FB} pin. LED current is adjustable by DC voltage and resistors, R1 and R2 in the following figure.

$$I_{LED} = (DC - 0.2) / R2 - 0.2 / R1$$

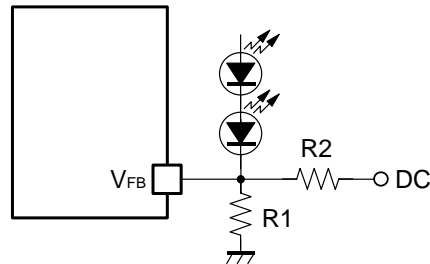

Dimming control by DC voltage

(3) Dimming control by feedback voltage and filtered PWM signal

LED dimming control is also possible by using the feedback voltage and filtered PWM signal.

LED current is adjustable according to the "H" level (V_H) and "L" level (V_L) of PWM signal and resistors,

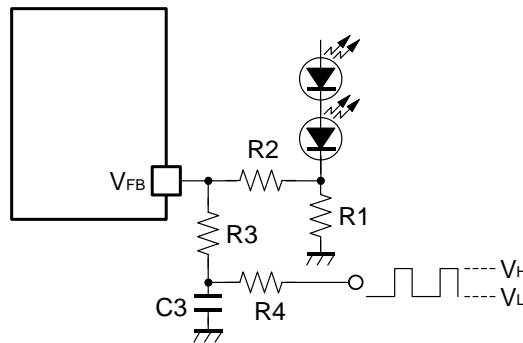

Dimming control by filtered PWM signal

R1, R2, R3, and R4 in the figure 5. Duty=0% to 100% PWM signal duty cycle can be used up to the maximum LED current and minimum LED current as in the next formulas.

$$I_{LED\text{MIN}} = (0.2 - R2 \times (V_H - 0.2) / (R3 + R4)) / R1$$

$$I_{LED\text{MAX}} = (0.2 - R2 \times (V_L - 0.2) / (R3 + R4)) / R1$$

For example, supposed that the PWM signal level is set as 2.5V/0V, to adjust the LED current range from 0mA to 20mA by the duty cycle, our recommendation external components values are, $R1=10\Omega$, $R2=5.1k\Omega$, $R3=51k\Omega$, $R4=5.1k\Omega$ or around.

C3 should be set large enough to regard the PWM signal as adjustable DC voltage by the filter. In this method, higher frequency control than the frequency against the CE pin can be used for dimming control.

For example, if the frequency is 40kHz, 0.1 μF or more capacitor is our recommendation value as C3.

• Selection of Inductors

The peak current of the inductor at normal mode can be calculated as next formula:

$$I_{Lxpeak} = 1.25 \times I_{LED} \times V_{OUT} / V_{IN} + 0.5 \times V_{IN} \times (V_{OUT} - V_{IN}) / (L \times V_{OUT} \times f_{osc})$$

When the start-up or dimming control by CE pin, transient current flows, the peak current must be equal or less than the current limit of the IC. The peak current should not beyond the rating current of the inductor. For example, for 4 serial LED drive from $V_{IN}=3.6V$, recommendation value of the inductor is 22 μH or more.

• Selection of Capacitors

Set 1 μF or more value bypass capacitor C1 between V_{IN} pin and GND pin as close as possible.

Set 0.22 μF or more capacitor C2 between V_{OUT} and GND pin.

TEST CIRCUITS

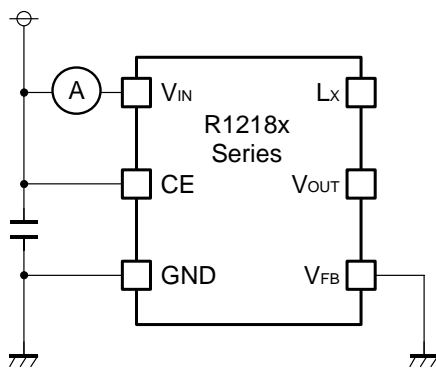

Supply Current Test Circuit

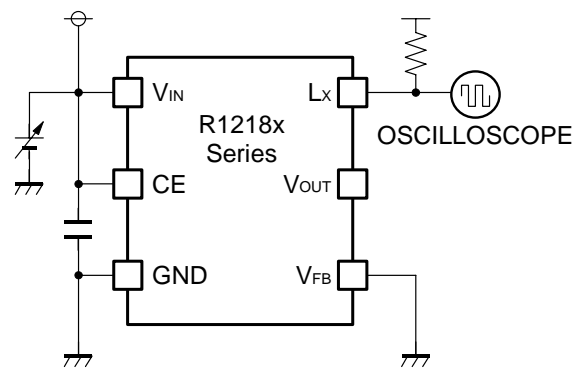

**UVLO Detector Threshold,
UVLO Released Voltage**

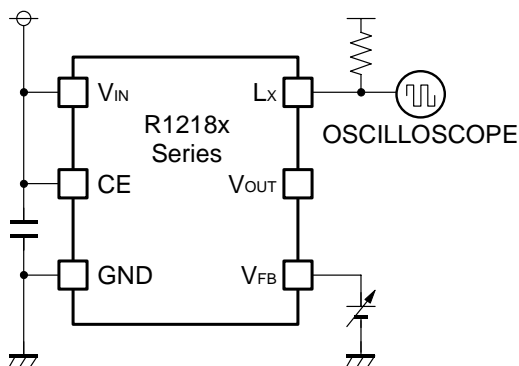

**VFB Voltage, Oscillator Frequency,
Maximum Duty Test Circuit**

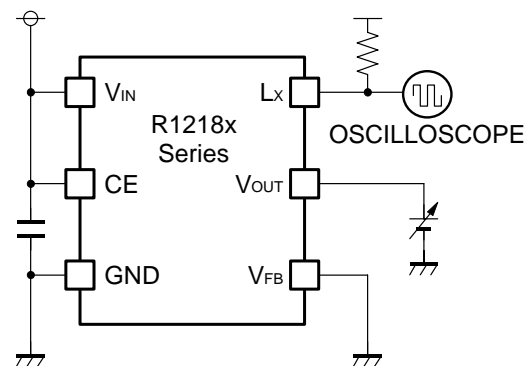

**OVP Detector Threshold,
OVP Released Voltage Test Circuit**

TYPICAL CHARACTERISTICS

1) Efficiency vs. LED Current (2LED) L: LQH32CN220 (Topt=25°C)

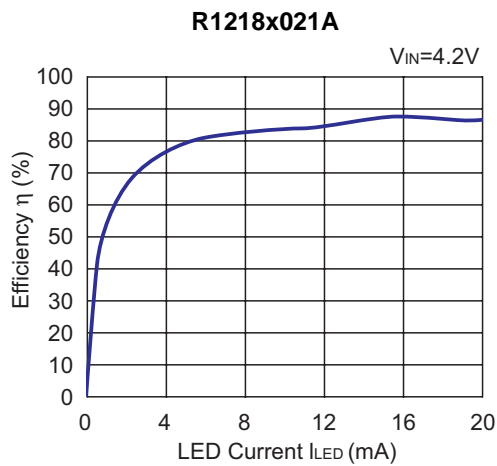
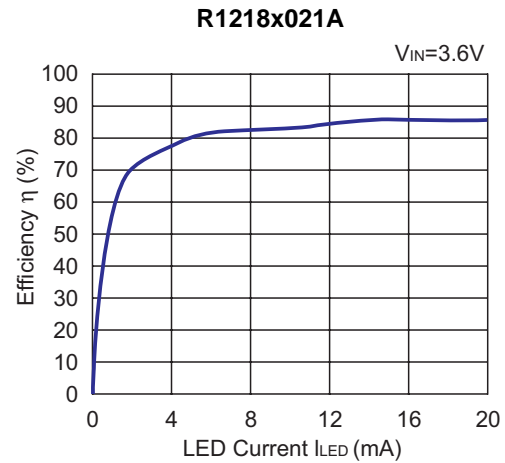
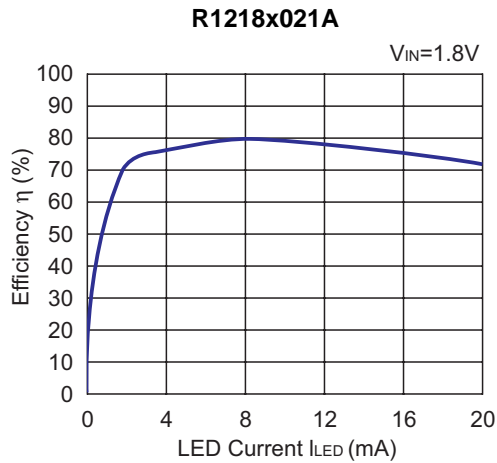

2) Efficiency vs. LED Current (3LED) L: LQH32CN220 (Topt=25°C)

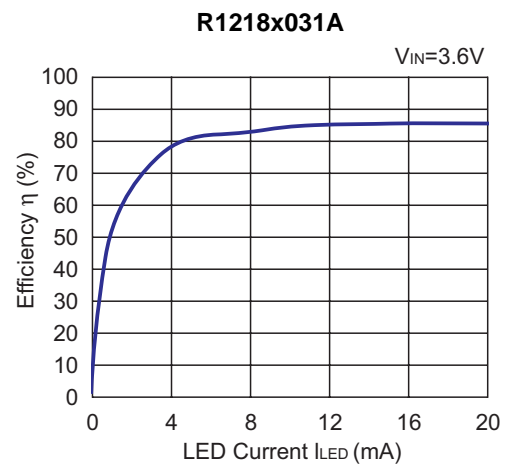
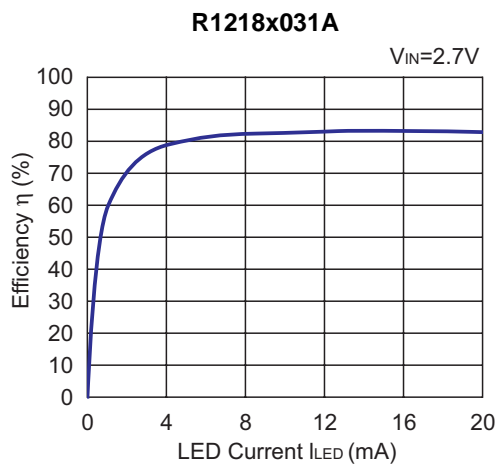

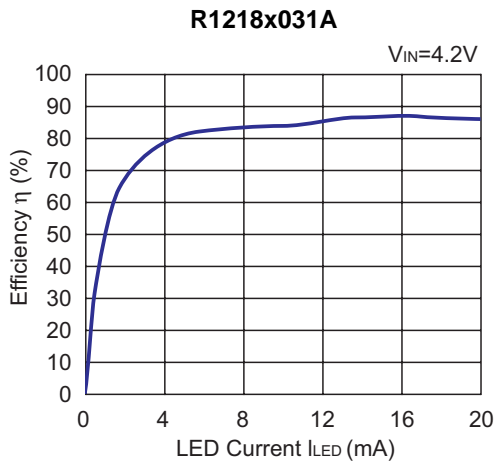

3) Efficiency vs. LED Current (4 LED) L: LQH32CN220 (T_{opt}=25°C)

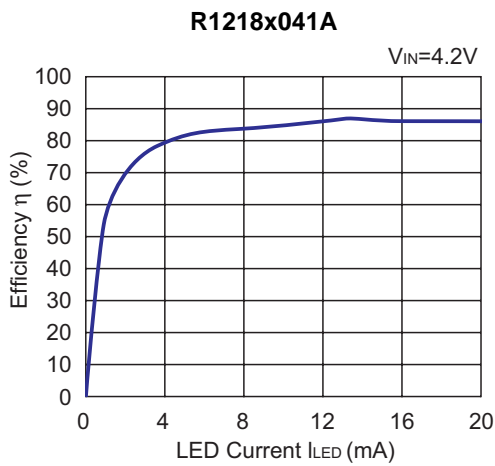
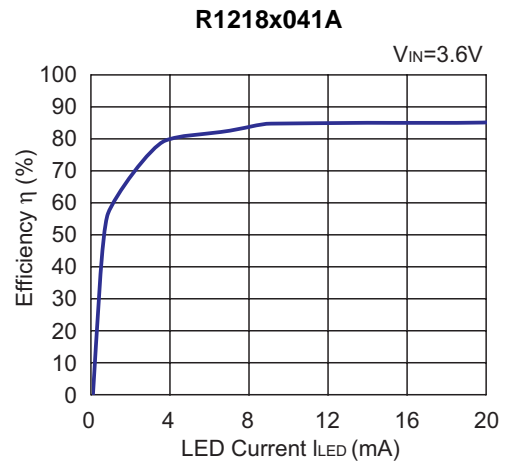
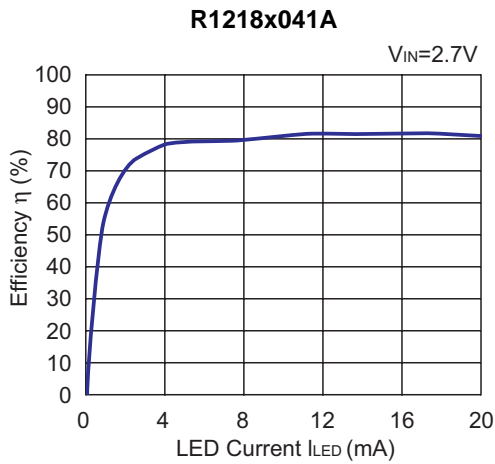

4) Efficiency vs. LED Current (6LED) L: LQH32CN220, Diode: CRS02 (Topt=25°C)

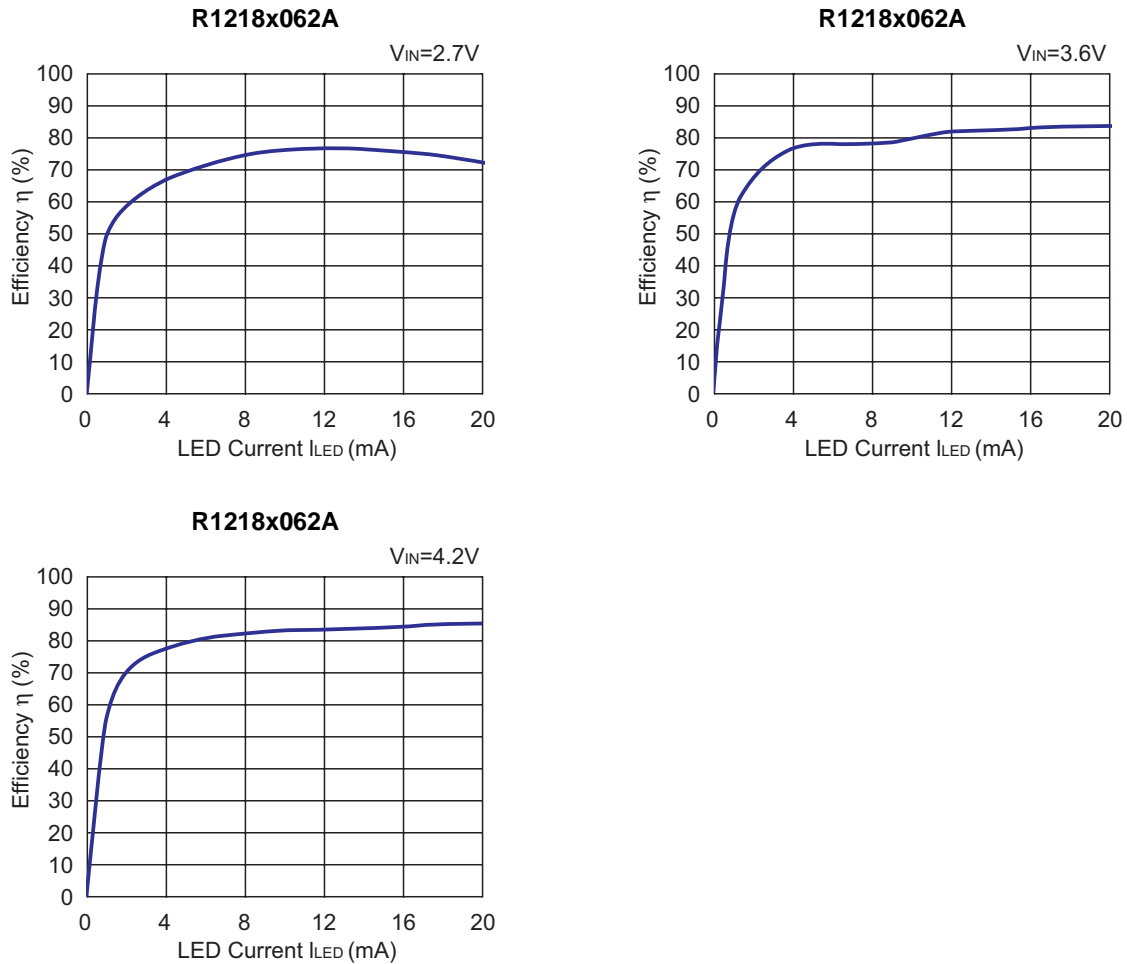

5) PWM Dimming Control (2 LED) VIN=3.6V, R1=10Ω

5-1. Duty vs. LED Current (Topt=25°C)

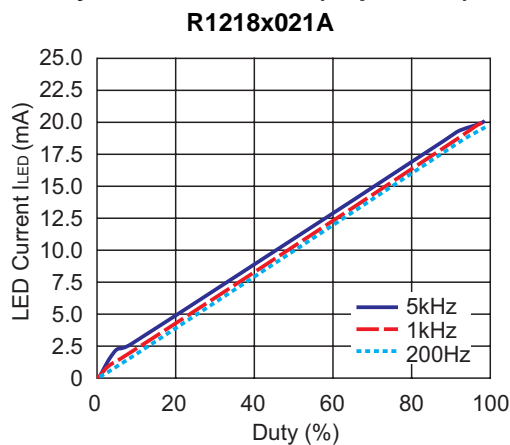

5-2. Output Voltage Waveform (T_{opt}=25°C)

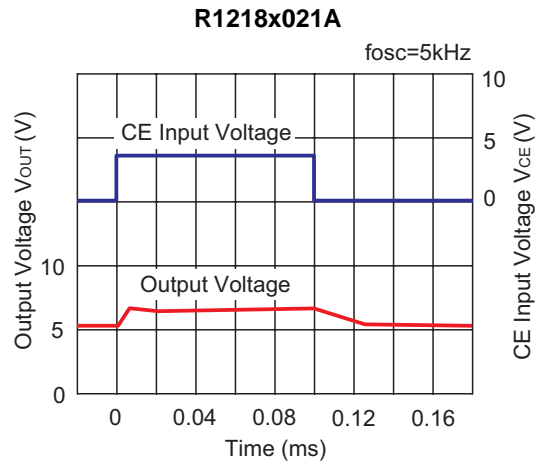
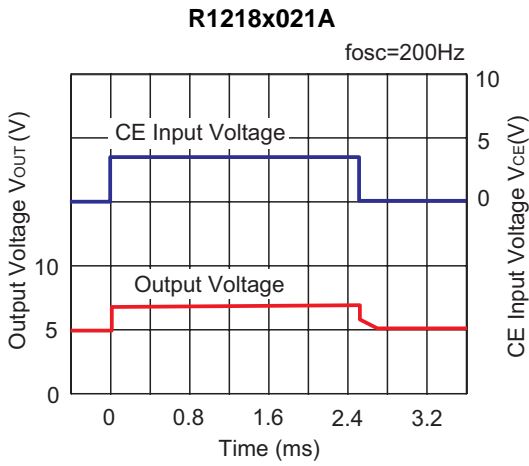

6) PWM Dimming Control (4 LED) V_{IN}=3.6V, R₁=10Ω

6-1. Duty vs. LED Current (T_{opt}=25°C)

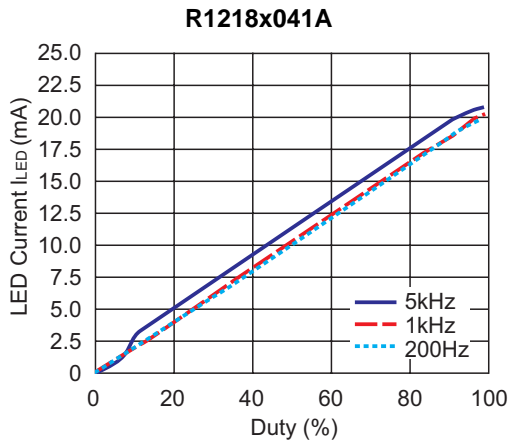

6-2. Output Voltage Waveform (4 LED) (T_{opt}=25°C)

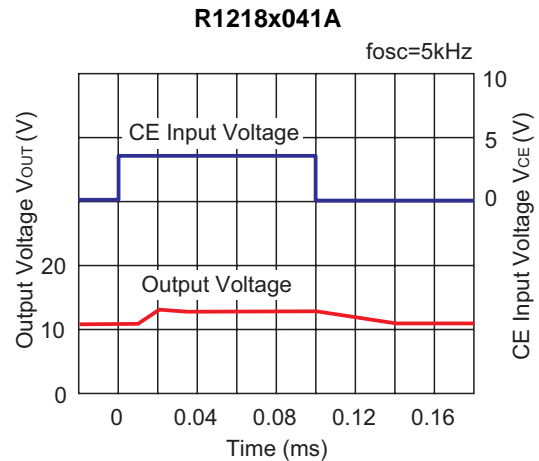
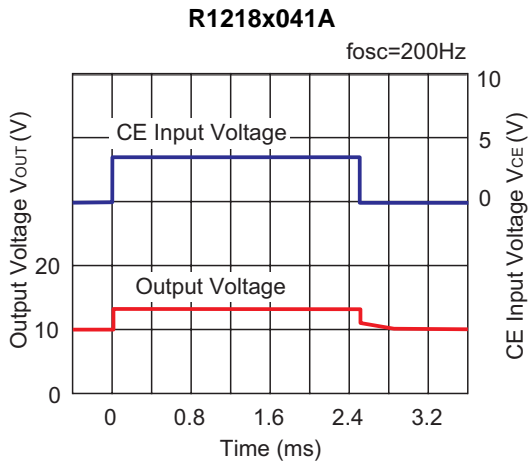

7) PWM Dimming Control (6 LED) $V_{IN}=3.6V$, $R1=10\Omega$

7-1. Duty vs. LED Current ($T_{opt}=25^\circ C$)

R1218x062A

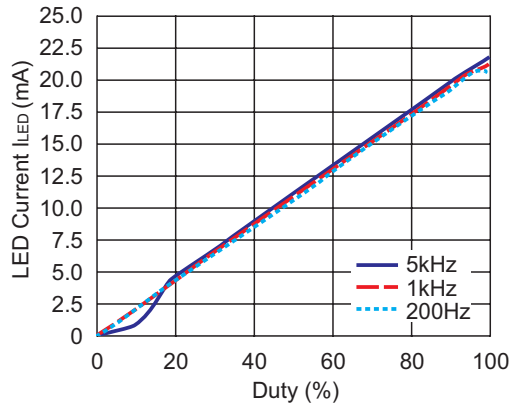

7-2. Output Voltage Waveform (6 LED) ($T_{opt}=25^\circ C$)

R1218x062A

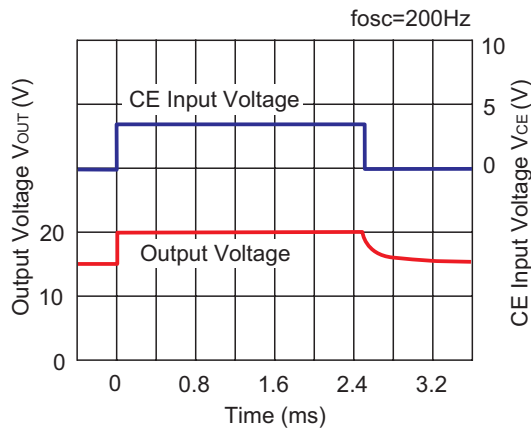

R1218x062A

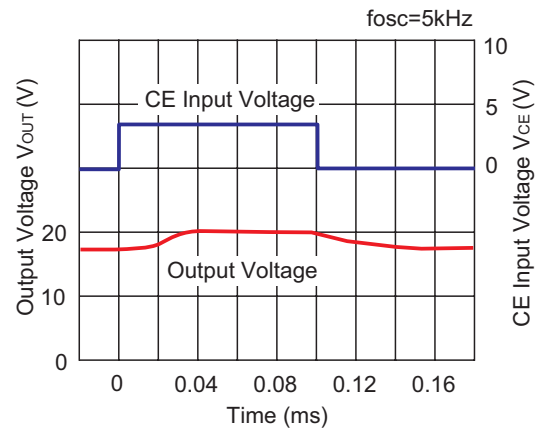

8) V_{FB} Voltage vs. Temperature

R1218x041A

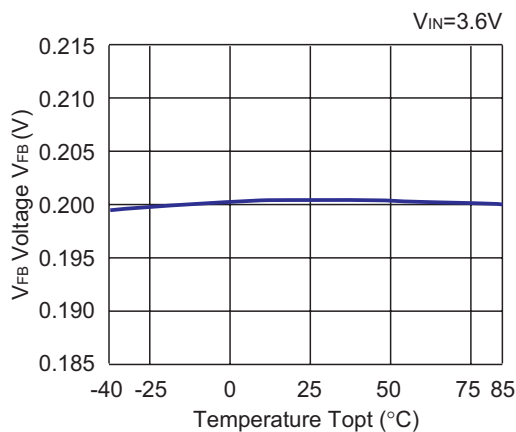

9) UVLO Detector Threshold/Released Voltage vs. Temperature

R1218x041A

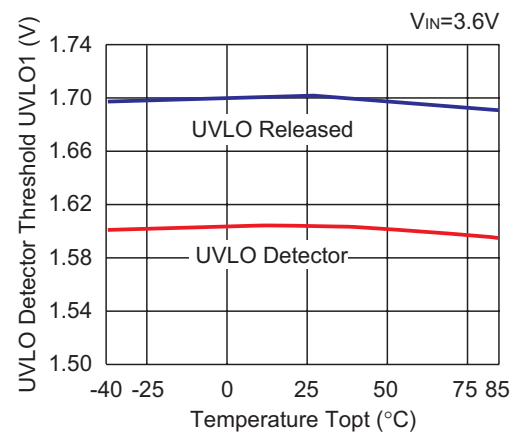

10) Oscillator Frequency vs. Temperature
R1218x041A

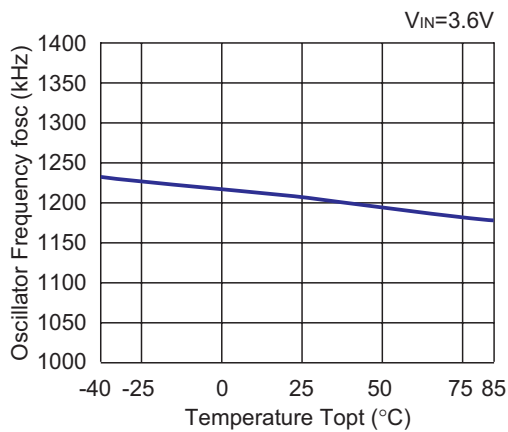

11) Maximum duty cycle vs. Temperature
R1218x041A

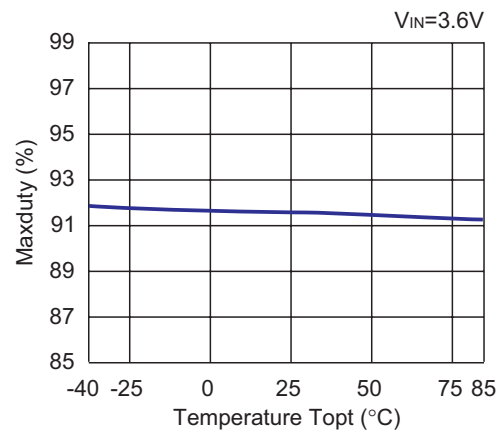

12) OVP Detector Threshold/Released Voltage vs. Temperature
R1218x041A

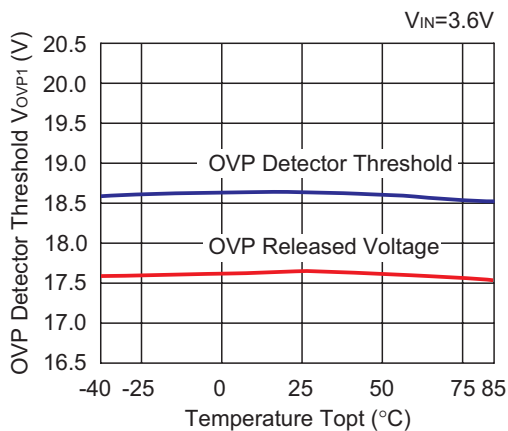

13) Supply Current vs. Temperature
R1218x041A

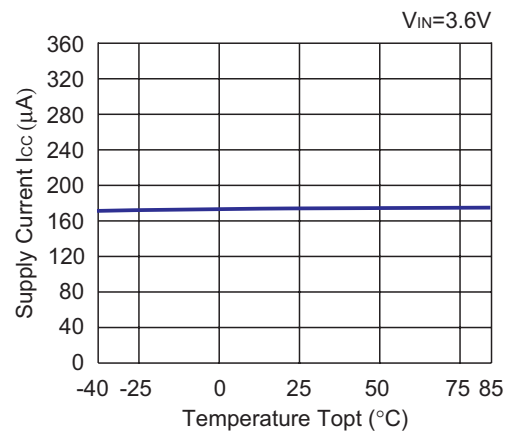

14) Lx Current Limit vs. Temperature
R1218x041A

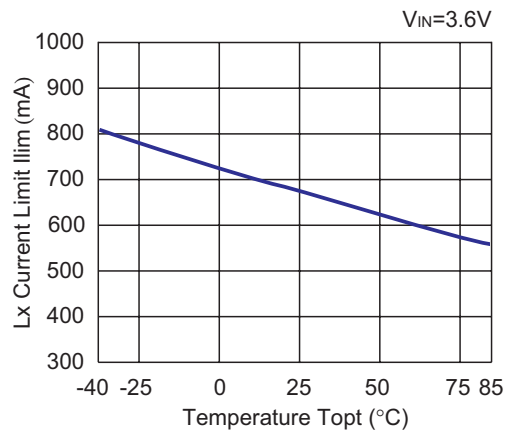

15) OVP Transient Response (Topt=25°C)

R1218x021A

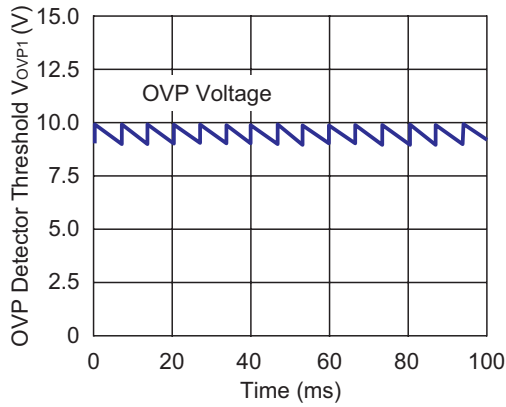

R1218x041A

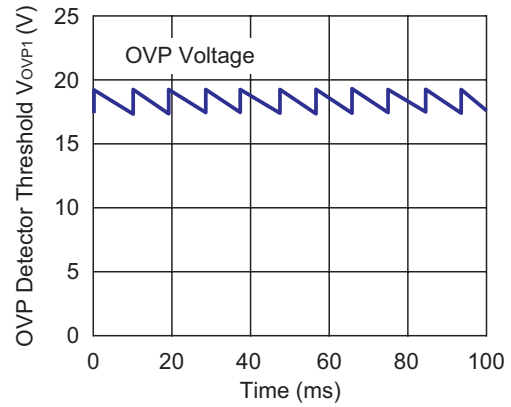

R1218x062A

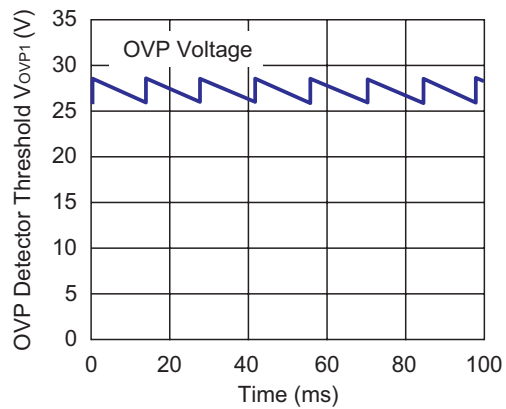

16) Efficiency dependence on inductors (4 LED)

R1218x041A (Internal Diode Type)

V_{IN}=3.6V

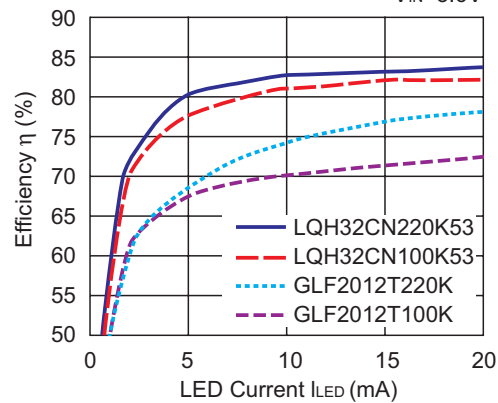

• SOT-23-6 (SC-74)

Unit: mm

PACKAGE DIMENSIONS

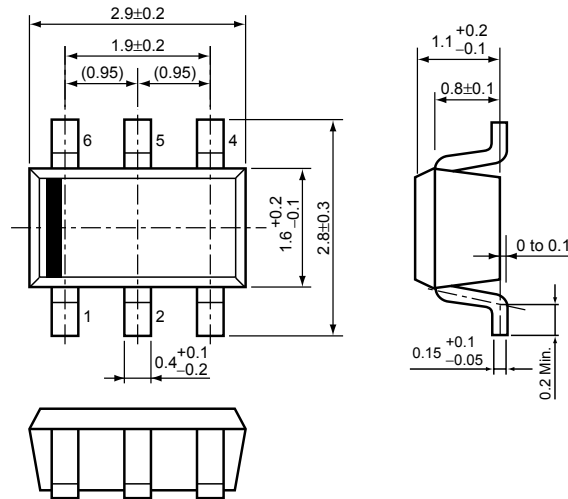

TAPING SPECIFICATION

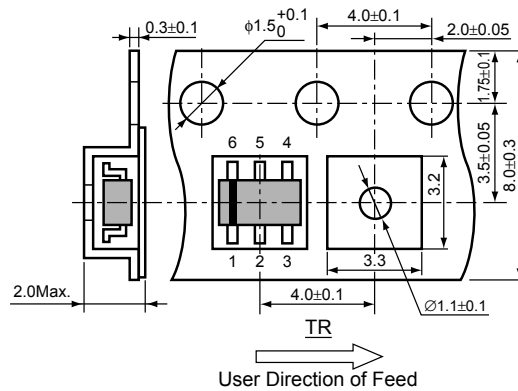

TAPING REEL DIMENSIONS REUSE REEL (EIAJ-RRM-08Bc)

(1reel=3000pcs)

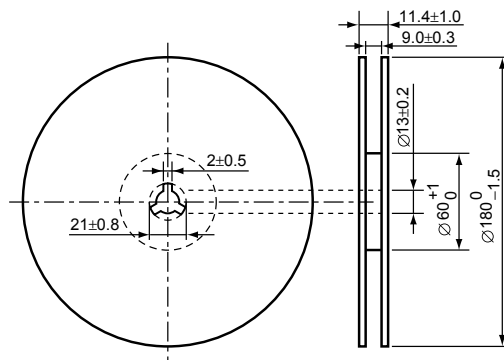

POWER DISSIPATION (SOT-23-6)

This specification is at mounted on board. Power Dissipation (P_D) depends on conditions of mounting on board. This specification is based on the measurement at the condition below:

Measurement Conditions

	Standard Land Pattern
Environment	Mounting on Board (Wind velocity=0m/s)
Board Material	Glass cloth epoxy plactic (Double sided)
Board Dimensions	40mm × 40mm × 1.6mm
Copper Ratio	Top side : Approx. 50% , Back side : Approx. 50%
Through-hole	φ0.5mm × 44pcs

Measurement Result

($T_{opt}=25^{\circ}C, T_{jmax}=125^{\circ}C$)

	Standard Land Pattern	Free Air
Power Dissipation	420mW	250mW
Thermal Resistance	$\theta_{ja}=(125-25^{\circ}C)/0.42W=263^{\circ}C/W$	400 $^{\circ}C/W$

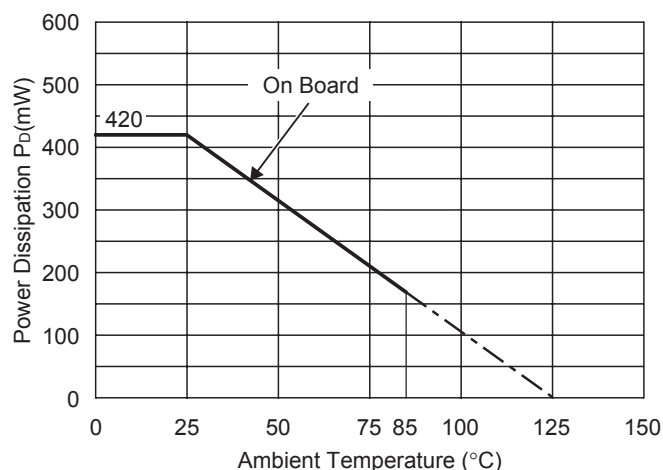

Power Dissipation

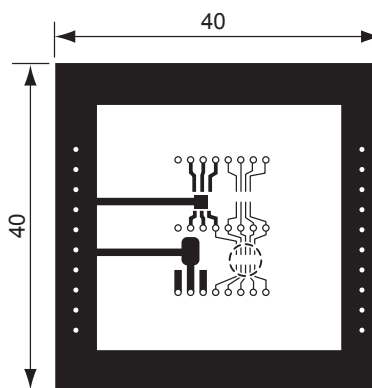

Measurement Board Pattern

○ IC Mount Area Unit : mm

RECOMMENDED LAND PATTERN

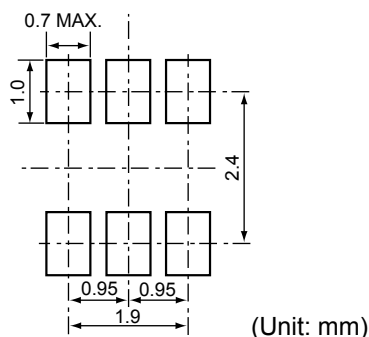

POWER DISSIPATION (PLP1820-6)

This specification is at mounted on board. Power Dissipation (P_D) depends on conditions of mounting on board. This specification is based on the measurement at the condition below:

Measurement Conditions

	Standard Land Pattern
Environment	Mounting on Board (Wind velocity=0m/s)
Board Material	Glass cloth epoxy plactic (Double sided)
Board Dimensions	40mm × 40mm × 1.6mm
Copper Ratio	Top side : Approx. 50% , Back side : Approx. 50%
Through-hole	φ0.54mm × 30pcs

Measurement Result

($T_{opt}=25^{\circ}C, T_{jmax}=125^{\circ}C$)

	Standard Land Pattern
Power Dissipation	880mW
Thermal Resistance	$\theta_{ja}=(125-25^{\circ}C)/0.88W=114^{\circ}C/W$

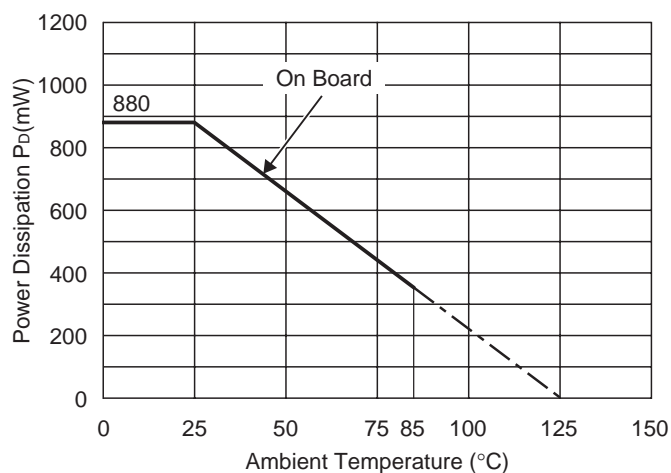

Power Dissipation

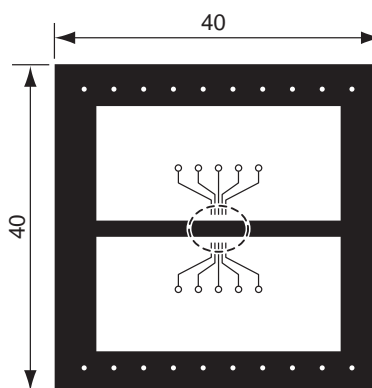

Measurement Board Pattern

○ IC Mount Area Unit : mm

RECOMMENDED LAND PATTERN

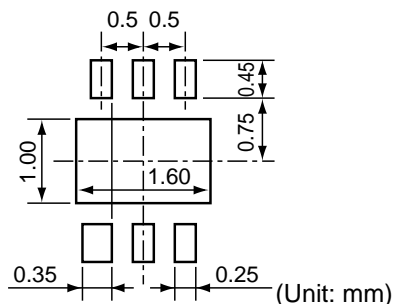

(Unit: mm)

RICOH

R1218N SERIES MARK SPECIFICATION

- SOT-23-6 (SC-74)

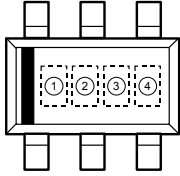

①, ② : Product Code (refer to Part Number vs. Product Code)

③, ④ : Lot Number

- Part Number vs. Product Code

Part Number	Product Code	
	①	②
R1218N021A	2	A
R1218N031A	2	B
R1218N041A	2	C
R1218N022A	2	D
R1218N032A	2	E
R1218N042A	2	F
R1218N052A	2	G
R1218N062A	2	H

R1218K SERIES MARK SPECIFICATION

- **PLP1820-6**

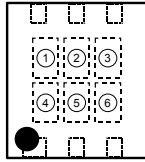

① to ④ : Product Code (refer to Part Number vs. Product Code)

⑤, ⑥ : Lot Number

- **Part Number vs. Product Code**

Part Number	Product Code			
	①	②	③	④
R1218K021A	Y	0	0	1
R1218K031A	Y	0	0	2
R1218K041A	Y	0	0	3
R1218K022A	Y	0	0	4
R1218K032A	Y	0	0	5
R1218K042A	Y	0	0	6
R1218K052A	Y	0	0	7
R1218K062A	Y	0	0	8