

4-ch Motor Driver for Portable CD Players

Monolithic IC MM1538

Outline

This IC is a driver IC integrating a 4-ch H-bridge driver and a DC-DC converter control circuit into one chip, which was developed for portable CD players. It is ideal for smaller sets as QFP-44B is used for the package.

Features

1. Includes a 4-ch H-bridge driver and allows the load drive voltage to be PWM-controlled with external components
2. Incorporates a DC-DC converter control circuit
3. Includes a reverting output pin for reset output
4. Allows switching of empty detection level for rechargeable batteries and dry batteries
5. Resistance value can be changed in the constant-current charging system with an external resistor
6. Includes a power transistor for charging
7. Incorporates an independent thermal shutdown circuit

Package

QFP-44B

Application

Portable CD radio cassette players

Block Diagram

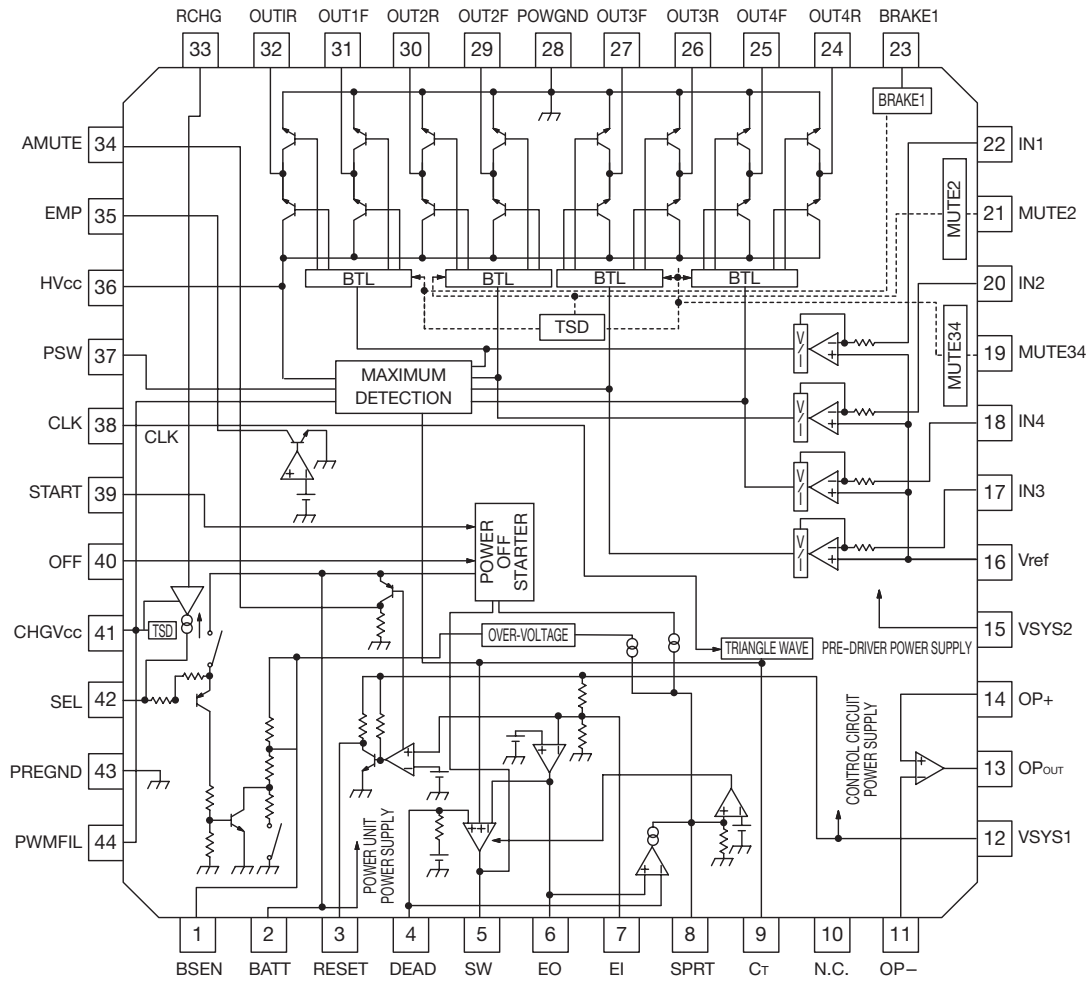

Pin Assignment

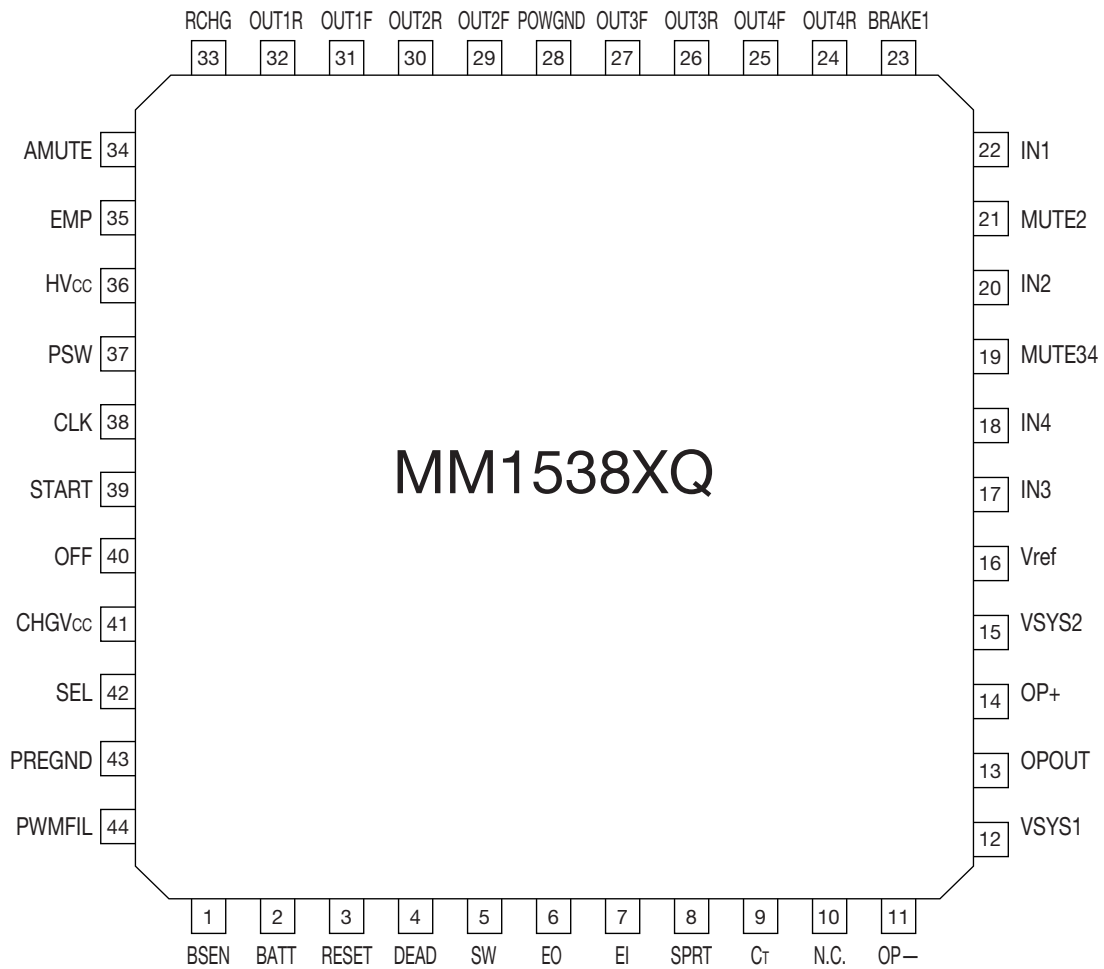

1	BSEN	23	BRAKE1
2	BATT	24	OUT4R
3	RESET	25	OUT4F
4	DEAD	26	OUT3R
5	SW	27	OUT3F
6	EO	28	POWGND
7	EI	29	OUT2F
8	SPRT	30	OUT2R
9	C _T	31	OUT1F
10	N.C.	32	OUT4R
11	OP-	33	RCHG
12	VSYS1	34	AMUTE
13	OPOUT	35	EMP
14	OP+	36	HV _{CC}
15	VSYS2	37	PSW
16	Vref	38	CLK
17	IN3	39	START
18	IN4	40	OFF
19	MUTE34	41	CHGV _{CC}
20	IN2	42	SEL
21	MUTE2	43	PREGND
22	IN1	44	PWMFIL

Pin Description

Pin No.	Pin Name	Input/Output	Function	Internal Equivalent Circuit
1	BSEN	Input	Battery Voltage Monitor	
2	BATT	Input	Battery Power Supply Input	Power Supply
3	RESET	Output	Reset Detect Output	
4	DEAD	Input	DEAD Time Setting	
5	SW	Output	Transistor Drive For Voltage Multiplier	
6	EO	Output	Error Amplifier Output	

Pin Description

Pin No.	Pin Name	Input/Output	Function	Internal Equivalent Circuit
7	EI	Input	Error Amplifier Input	
8	SPRT	Output	Short Circuit Protection Setting	
9	CT	Output	Triangular-Wave Output	
10	N.C.			
11 14	OP- OP+	Input	Op Amp Negative Input Op Amp Positive Input	
12	VSYS1	Input	Control Circuit Power Supply Input	Control Circuit Power Supply
13	OPOUT	Output	Op Amp Output	

Pin Description

Pin No.	Pin Name	Input/Output	Function	Internal Equivalent Circuit
15	VSYS2	Input	Driver Pre-step Power Supply	Pre-Drive Power Supply
16	Vref	Input	Reference Voltage Input	
17	IN3	Input	ch3 Control Signal Input	
18	IN4		ch4 Control Signal Input	
20	IN2		ch2 Control Signal Input	
22	IN1		ch1 Control Signal Input	
19	MUTE34	Input	ch3 and 4 Mute	
21	MUTE2		ch2 Mute	
23	BRAKE1		ch1 Brake	
24	OUT4R	Output	ch4 Negative Output	
25	OUT4F		ch4 Positive Output	
26	OUT3R		ch3 Negative Output	
27	OUT3F		ch3 Positive Output	
29	OUT2F		ch2 Positive Output	
30	OUT2R		ch2 Negative Output	
31	OUT1F		ch1 Positive Output	
32	OUT1R		ch1 Negative Output	
28	POWGND			
36	HVcc	Input	H-Bridge Power Supply Input	
33	RCHG	Input	Charge Current Setting	

Pin Description

Pin No.	Pin Name	Input/Output	Function	Internal Equivalent Circuit
34	AMUTE	Output	Reset Invert Output	
35	EMP	Output	Empty Detect Output	
37	PSW	Output	PWM Transistor Drive	
38	CLK	Input	External Clock Synchronizing Input	
39	START	Input	Voltage Multiplier DC-DC Converter Start	
40	OFF	Input	Voltage Multiplier DC-DC Converter OFF	

Pin Description

Pin No.	Pin Name	Input/Output	Function	Internal Equivalent Circuit
41	CHGV _{CC}	Input	Charging Circuit Power Supply Input	Charging Circuit Power Supply
42	SEL	Input Output	Empty Detect Level Switch	
43	PREGND		Pre Section Power Supply Ground	Pre Section Power Supply Ground
44	PWMFIL	Input	PWM Phase Compensation	

* The positive and negative outputs are the polarity with respect to the input

Absolute Maximam Ratings (Ta=25°C)

Item	Symbol	Rating	Unit
Supply Voltage	V _{CC} *1	13.5	V
Driver Output Current	I _o	500	mA
Power Dissipation	P _d	625 *2	mW
Operating Temperature	T _{OPR}	-30 ~ +85	°C
Storage Temperature	T _{STG}	-55 ~ +150	°C

*1 V_{cc} shows input voltage of VSYS1,VSYS2,HV_{cc},BATT,and CHGV_{cc}.

*2 Reduced by 5mW for each increase in Ta of 1°C over 25°C.

Recommended Operating Conditions

Item	Symbol	Min.	Typ.	Max.	Unit
Control Circuit Power Supply Voltage	VSYS1	2.7	3.2	5.5	V
Pre-Driver Circuit Power Supply Voltage	VSYS2	2.7	3.2	5.5	V
H-Bridge Power Supply Voltage	HV _{CC}		PWM	BATT	V
Power Supply Voltage	BATT	1.5	2.4	8.0	V
Charging circuit Power Supply Voltage	CHGV _{CC}	3.0	4.5	8.0	V
Operating Temperature	T _a	-10	25	70	°C

Electrical Characteristics

(unless otherwise specified, Ta=25°C , BATT=2.4V, VSYS1=VSYS2=3.2V,Vref=1.6V, CHGV_{cc}=0V,fCLK=88.2kHz)

Item	Symbol	Measurement Conditions	Min.	Typ.	Max.	Unit
<Common Section>						
BATT Stand-by Current	I _{ST}	BATT=9.0V, VSYS1=VSYS2=Vref=0V		0	3	μA
BATT Supply Current (No load)	I _{BAT}	HV _{CC} =0.45V, MUTE34=3.2V		2.5	4.0	mA
VSYS1 Supply Current (No load)	I _{SY1}	HV _{CC} =0.45V, MUTE34=3.2V, EI=0V		4.7	6.4	mA
VSYS2 Supply Current (No load)	I _{SY2}	HV _{CC} =0.45V, MUTE34=3.2V		4.1	5.5	mA
CHGV _{cc} Supply Current (No load)	I _{CGVCC}	CHGV _{CC} =4.5V, R _{OUT} =OPEN		0.65	2.00	mA
<H-Bridge Driver Part>						
Voltage Gain ch1,ch3,ch4	G _{VCI34}		12	14	16	dB
Voltage Gain ch2	G _{VC2}		21.5	23.5	24.5	dB
Gain Error By Polarity	ΔG _{VC}		-2	0	2	dB
Input pin resistance ch1,ch3,ch4	R _{IN134}	IN=1.7V and 1.8V	9	11	13	kΩ
Input pin resistance ch2	R _{IN2}	IN=1.7V and 1.8V	6	7.5	9	kΩ
Maximum Output Voltage	V _{OUT}	R _L =8Ω, HV _{cc} =BATT=4.0V, IN=0-3.2V	1.9	2.1		V
Saturation Voltage (Lower)	V _{satL}	I _o =-300mA, IN=0 and 3.2V		240	400	mV
Saturation Voltage (Upper)	V _{satU}	I _o =-300mA, IN=0 and 3.2V		240	400	mV
Input Offset Voltage	V _{OI}		-8	0	8	mV
Output Offset Voltage ch1,ch3,ch4	V _{OO134}	Vref=IN=1.6V	-50	0	50	mV
Output Offset Voltage ch2	V _{OO2}	Vref=IN=1.6V	-130	0	130	mV
Dead Zone	V _{DB}		-10	0	10	mV
BRAKE1ON Threshold Voltage	V _{BRON}	IN1=1.8V	2.0			V
BRAKE1OFF Threshold Voltage	V _{BROFF}	IN1=1.8V			0.8	V
MUTE2 ON Threshold Voltage	V _{M2ON}	IN2=1.8V	2.0			V

Electrical Characteristics

(unless otherwise specified, Ta=25°C, BATT=2.4V, VSYS1=VSYS2=3.2V, Vref=1.6V, CHGVcc=0V, fCLK=88.2kHz)

Item	Symbol	Measurement Conditions	Min.	Typ.	Max.	Unit
<H-Bridge Driver Part>						
MUTE2 OFF Threshold Voltage	V _{M2OFF}	IN2=1.8V			0.8	V
MUTE34 ON Threshold Voltage	V _{M34ON}	IN3=IN4=1.8V			0.8	V
MUTE34 OFF Threshold Voltage	V _{M34OFF}	IN3=IN4=1.8V	2.0			V
Vref ON Threshold Voltage	V _{refON}	IN1=IN2=IN3=IN4=1.8V	1.2			V
Vref OFF Threshold Voltage	V _{refOFF}	IN1=IN2=IN3=IN4=1.8V			0.8	V
BRAKE1 Brake Current	I _{BRAKE1}	Current difference between BRAKE pin "H" time and "L" time.	4	7	10	mA
<PWM Power Supply Driving>						
PSW Sink Current	I _{PSW}	IN1=2.1V	10	13	17	mA
HVcc Level Shift Voltage	V _{SHIF}	IN1=1.8V, HVcc-OUT1F	0.35	0.45	0.55	V
HVcc Leak Current	I _{HCLK}	HVcc=9.0V, VSYS1=VSYS2=BATT=0V		0	5	μA
PWM Amp Transfer Gain	G _{PWM}	IN1=1.8V, HVcc=1.2 ~ 1.4V	1/60	1/50	1/40	1/kΩ
<DC-DC Converter>						
<Error Amp>						
VSYS1 Threshold Voltage	V _{S1TH}		3.05	3.20	3.35	V
EO Pin Output Voltage "H"	V _{EOH}	EI=0.7V, I _o =-100μA	1.4	1.6		V
EO Pin Output Voltage "L"	V _{EOL}	EI=1.3V, I _o =100μA			0.3	V
<Short Circuit Protection>						
SPRT Pin Voltage	V _{SPR}	EI=1.3V		0	0.1	V
EO=H SPRT Pin Current1	I _{SPR1}	EI=0.7V	6	10	16	μA
OFF=L SPRT Pin Current2	I _{SPR2}	EI=1.3V, OFF=0V	12	20	32	μA
SPRT Pin Current3 Over-Voltage	I _{SPR3}	EI=1.3V, BATT=9.5V	12	20	32	μA
SPRT Pin Impedance	R _{SPR}		175	220	265	kΩ
SPRT Pin Threshold Voltage	V _{SPTH}	EI=0.7V, C _T =0V	1.10	1.20	1.30	V
Over-Voltage Protection Detect	V _{HVPR}	BSEN Pin Voltage	8.0	8.4	9.0	V
<Transistor Driving>						
SW Pin Output Voltage1 "H"	V _{SW1H}	BATT=C _T =1.5V, VSYS1=VSYS2=0V, I _o =-2mA Starting Time	0.78	0.98	1.13	V
SW Pin Output Voltage2 "H"	V _{SW2H}	C _T =0V, I _o =-10mA, EI=0.7V, SPRT=0V	1.00	1.50		V
SW Pin Output Voltage2 "L"	V _{SW2L}	C _T =2.0V, I _o =10mA		0.30	0.45	V
SW Pin Oscillating Frequency1	f _{SW1}	C _T =470pF, VSYS1=VSYS2=0V Starting Time	65	80	95	kHz
SW Pin Oscillating Frequency2	f _{SW2}	C _T =470pF, CLK=0V	60	70	82	kHz
SW Pin Oscillating Frequency3	f _{SW3}	C _T =470pF		88.2		kHz
SW Pin Minimum Pulse Width	T _{SWmin}	C _T =470pF, EO=0.5V→ 0.7V Sweep	0.01		0.60	μs
Pulse Duty Start	D _{SW1}	C _T =470pF, VSYS1=VSYS2=0V	40	50	60	%
Max.Pulse Duty At Self-Running	D _{SW2}	C _T =470pF, EI=0.7V, CLK=0V	70	80	90	%
Max. Pulse Duty At CLK Synchronization	D _{SW3}	C _T =470pF, EI=0.7V	65	75	85	%
<Interface>						
OFF Pin Threshold Voltage	V _{OFTH}	EI=1.3V			VSYS1-2.0	V
OFF Pin Bias Current	I _{OFF}	OFF=0V	75	95	115	μA
START Pin ON Threshold Voltage	V _{STATH1}	VSYS1=VSYS2=0V, C _T =2.0V			BATT-1.0	V
START Pin OFF Threshold Voltage	V _{STATH2}	VSYS1=VSYS2=0V, C _T =2.0V	BATT-0.3			V

Electrical Characteristics

(unless otherwise specified, Ta=25°C, BATT=2.4V, VSYS1=VSYS2=3.2V, Vref=1.6V, CHGVCC=0V, fCLK=88.2kHz)

Item	Symbol	Measurement Conditions	Min.	Typ.	Max.	Unit
<Interface>						
START Pin Bias Current	I _{START}	START=0V	10	20	30	μA
			13	16	19	
CLK Pin Threshold Voltage"H"	V _{CLKTHH}		2.0			V
CLK Pin Threshold Voltage"L"	V _{CLKTHL}				0.8	V
CLK Pin Bias Current	I _{CLK}	CLK=3.2V			10	μA
<Dead Time>						
DEAD Pin Impedance	R _{DEAD}		52	65	78	kΩ
DEAD Pin Output Voltage	V _{DEAD}		0.78	0.88	0.98	V
<Starter Circuit>						
Starter Switching Voltage	V _{STNM}	VSYS1=VSYS2=0V→3.2V, START=0V	2.3	2.5	2.7	V
Starter Switching Hysteresis Width	V _{SNHS}	START=0V	130	200	300	mV
Discharge Release	V _{DIS}		1.63	1.83	2.03	V
<Empty Detection>						
EMP Detection Voltage 1	V _{EMPT1}	VSEL=0V	2.1	2.2	2.3	V
EMP Detection Voltage 2	V _{EMPT2}	ISEL=-2μA	1.7	1.8	1.9	V
EMP Detection Hysteresis Voltage 1	V _{EMHS1}	VSEL=0V	25	50	100	mV
EMP Detection Hysteresis Voltage 2	V _{EMHS2}	ISEL=-2μA	25	50	100	mV
EMP Pin Output Voltage	V _{EMP}	I _o =1mA, BSEN=1V			0.5	V
EMP Pin Output Leak Current	I _{EMPL}	BSEN=2.4V			1.0	μA
BSEN Pin Input Resistance	R _{BSEN}	VSEL=0V	17	23	27	kΩ
BSEN Pin Leak Current	I _{BSENL}	VSYS1=VSYS2=0V, BSEN=4.5V			1.0	μA
SEL Pin Detection Voltage	V _{SELTH}	V _{SELTH} =BATT-SEL, BSEN=2.0V	1.5			V
SEL Pin Detection Current	I _{SELT}		-2			μA
<Reset Circuit>						
VSYS1 RESET Threshold Voltage Ratio	H _{SRT}	Comparison with error amplifier threshold voltage	85	90	95	%
RESET Detection Hysteresis Width	V _{RSTHS}		25	50	100	mV
RESET Pin Output Voltage	V _{RST}	I _o =1mA, VSYS1=VSYS2=2.8V			0.5	V
RESET Pin PULL UP Resistance	R _{RST}		72	90	108	kΩ
AMUTE Pin Output Voltage 1	V _{AMT1}	I _o =-1mA, VSYS1=VSYS2=2.8V	BATT-0.4		BATT	V
AMUTE Pin Output Voltage 2	V _{AMT2}	I _o =-1mA, START=0V, VSYS1=VSYS2=0V	BATT-0.4		BATT	V
AMUTE Pin PULL DOWN Resistance	R _{AMT}		77	95	113	kΩ
<Op Amp>						
Input Bias Current	I _{BIAS}	OP+=1.6V			300	nA
Input Offset Voltage	V _{OIOP}		-5.5	0	5.5	mV
High Level Output Voltage	V _{OHOP}	R _L =OPEN	2.8			V
Low level Output Voltage	V _{OLOP}	R _L =OPEN			0.2	V
Output Drive Current (Source)	I _{SOU}	50Ω GND		-6.5	-3.0	mA
Output Drive Current (Sink)	I _{SIN}	50Ω VSYS1	0.4	0.7		mA
Open Loop Voltage Gain	G _{VO}	V _{IN} =-75dBV, f=1kHz		70		dB
Slew Rate	SR			0.5		V/μs
<Battery Charging Circuit>						
RCHG Pin Bias Voltage	V _{RCHG}	CHGVCC=4.5V, RCHG=1.8kΩ	0.71	0.81	0.91	V

Switching Position Table

Item	SW No.									
	1	4	5	6	7	8	22	24	25	26
BATT Stand-by Current	-	-	-	-	-	-	-	-	-	-
BATT Supply Current (No load)	-	-	-	-	-	-	a	-	a	-
VSYS1 Supply Current (No load)	-	-	-	a	-	-	a	-	a	-
VSYS2 Supply Current (No load)	-	-	-	-	-	-	a	-	a	-
CHGVcc Supply Current (Noload)	-	-	-	-	-	-	-	-	-	-
VSYS1 Threshold Voltage	-	-	a	-	-	-	-	-	-	-
EO Pin Output Voltage "H"	-	-	a	a	-	-	-	-	-	-
EO Pin Output Voltage "L"	-	-	a	a	-	-	-	-	-	-
SPRT Pin Voltage	-	-	-	a	a	-	-	-	-	-
SPRT Pin Current1 EO="H"	-	-	-	a	b	-	-	-	-	-
SPRT Pin Current2 OFF="L"	-	-	-	a	b	-	-	-	-	a
SPRT Pin Current3 Over-Voltage	a	-	-	a	b	-	-	-	-	-
SPRT Pin Impedance	-	-	-	-	b	-	-	-	-	-
SPRT Pin Threshold Voltage	-	-	-	a	a	a	-	-	-	-
Over-Voltage Protection Detect	a	-	-	-	a	-	-	-	-	-
SW Pin Output Voltage1 "H"	-	a	-	-	-	a	-	-	a	-
SW Pin Output Voltage2 "H"	-	a	-	a	b	a	-	-	-	-
SW Pin Output Voltage2 "L"	-	a	-	-	-	a	-	-	-	-
SW Pin Oscillating Frequency 1	-	b	-	-	-	b	-	-	a	-
SW Pin Oscillating Frequency 2	-	b	-	-	-	b	-	b	-	-
SW Pin Oscillating Frequency 3	-	b	-	-	-	b	-	a	-	-
SW Pin Minimum Pulse Width	-	b	b	-	-	b	-	-	-	-
Pulse Duty Start	-	b	-	-	-	b	-	b	a	-
Max. Pulse Duty At Self-Running	-	b	-	-	-	b	-	b	-	-
Max. Pulse Duty At CLK Synchronization	-	b	-	a	-	b	-	a	-	-

- : Turn off switch

Switching Position Table

Item	SW No.									
	2	3	4	6	7	8	20	24	25	26
DEAD Pin Impedance	-	b	-	-	-	-	-	-	-	-
DEAD Pin Output Voltage	-	a	-	-	-	-	-	-	-	-
OFF Pin Threshold Voltage	-	-	-	a	a	-	-	-	-	a
OFF Pin Bias Current	-	-	-	-	-	-	-	-	-	a
START Pin ON Threshold Voltage	-	-	a	-	-	a	-	-	a	-
START Pin OFF Threshold Voltage	-	-	a	-	-	a	-	-	a	-
START Pin Bias Current	-	-	-	-	-	-	-	-	a	-
CLK Pin Threshold Voltage"H"	-	-	a	-	-	b	-	b	-	-
CLK Pin Threshold Voltage"L"	-	-	a	-	-	b	-	b	-	-
CLK Pin Bias Current	-	-	-	-	-	-	-	a	-	-
Starter Switching Voltage	-	-	a	-	-	-	-	-	a	-
Starter Switching Hysteresis Width	-	-	a	-	-	-	-	-	a	-
Discharge Release Voltage	-	-	-	-	a	-	-	-	-	-
VSYS1 Pin RESET Threshold Voltage Ratio	b	-	-	-	-	-	-	-	-	-
RESET Detection Hysteresis Width	b	-	-	-	-	-	-	-	-	-
RESET Pin Output voltage	b	-	-	-	-	-	-	-	-	-
RESET Pin PULL UP Resistance	a	-	-	-	-	-	-	-	-	-
AMUTE Pin Output Voltage 1	-	-	-	-	-	-	b	-	-	-
AMUTE Pin Output Voltage 2	-	-	-	-	-	-	b	-	a	-
AMUTE Pin PULL DOWN Resistance	-	-	-	-	-	-	a	-	-	-

- : Turn off switch

Switching Position Table

Item	SW No.						
	1	9	10	11	12	21	27
EMP Detection Voltage 1	a	-	-	-	-	a	a
EMP Detection Voltage 2	a	-	-	-	-	a	b
EMP Detection Hysteresis Voltage 1	a	a	-	-	-	a	a
EMP Detection Hysteresis Voltage 2	a	-	-	-	-	a	b
EMP Pin Output Voltage	a	-	-	-	-	b	-
EMP Pin Output Leak Current	a	-	-	-	-	c	-
BSEN Pin Input Resistance	a	-	-	-	-	-	a
BSEN Pin Leak Current	a	-	-	-	-	-	-
SEL Pin Detection Voltage	a	-	-	-	-	a	a
SEL Pin Detection Current	a	-	-	-	-	a	b
Input Bias Current	-	-	a	-	-	-	-
Input Offset Voltage	-	-	d	-	-	-	-
"H" Level Output Voltage	-	b	c	-	-	-	-
"L" Level Output Voltage	-	a	c	-	-	-	-
Output Drive Current (Source)	-	-	d	b	-	-	-
Output Drive Current (Sink)	-	-	d	a	-	-	-
Open Loop Voltage Gain	-	-	b	-	a	-	-
Slew Rate	-	-	d	-	a	-	-

- : Turn off switch

Switching Position Table

Item		SW No.						
		13	14	15	16	17	18	22
Voltage Gain	ch1R	-	-	-	b	b	b	a
	ch2R	-	-	b	-	b	b	a
	ch3R	b	-	-	-	b	b	a
	ch4R	-	b	-	-	b	b	a
Gain Error By Polarity	ch1	-	-	-	b	b	b	a
	ch2	-	-	b	-	b	b	a
	ch3	b	-	-	-	b	b	a
	ch4	-	b	-	-	b	b	a
Input pin resistance	ch1	-	-	-	b	b	b	a
	ch2	-	-	b	-	b	b	a
	ch3	b	-	-	-	b	b	a
	ch4	-	b	-	-	b	b	a
Maximum Output Voltage	ch1R	-	-	-	b	b	b	a
	ch2R	-	-	b	-	b	b	a
	ch3R	b	-	-	-	b	b	a
	ch4R	-	b	-	-	b	b	a
Saturation Voltage (Lower)	ch1F	-	-	-	b	a	-	a
	ch1R	-	-	-	b	-	a	a
	ch2F	-	-	b	-	a	-	a
	ch2R	-	-	b	-	-	a	a
	ch3F	b	-	-	-	a	-	a
	ch3R	b	-	-	-	-	a	a
	ch4F	-	b	-	-	a	-	a
	ch4R	-	b	-	-	-	a	a
Saturation Voltage (Upper)	ch1F	-	-	-	b	a	-	a
	ch1R	-	-	-	b	-	a	a
	ch2F	-	-	b	-	a	-	a
	ch2R	-	-	b	-	-	a	a
	ch3F	b	-	-	-	a	-	a
	ch3R	b	-	-	-	-	a	a
	ch4F	-	b	-	-	a	-	a
	ch4R	-	b	-	-	-	a	a
Input Offset Voltage	ch1	-	-	-	a	-	-	a
	ch2	-	-	a	-	-	-	a
	ch3	a	-	-	-	-	-	a
	ch4	-	a	-	-	-	-	a
Output Offset Voltage	ch1	-	-	-	b	b	b	a
	ch2	-	-	b	-	b	b	a
	ch3	b	-	-	-	b	b	a
	ch4	-	b	-	-	b	b	a
Dead Zone	ch1	-	-	-	b	b	b	a
	ch2	-	-	b	-	b	b	a
	ch3	b	-	-	-	b	b	a
	ch4	-	b	-	-	b	b	a

- : Turn off switch

Switching Position Table

Item		SW No.									
		13	14	15	16	17	18	22	23	28	
BRAKE1 ON Voltage	ch1	-	-	-	b	b	b	a	-	-	
BRAKE1 OFF Voltage	ch1	-	-	-	b	b	b	a	-	-	
MUTE2 ON Voltage	ch2	-	-	b	-	b	b	a	-	-	
MUTE2 OFF Voltage	ch2	-	-	b	-	b	b	a	-	-	
MUTE34 ON Voltage	ch3	b	-	-	-	b	b	a	-	-	
	ch4	-	b	-	-	b	b	a	-	-	
MUTE34 OFF Voltage	ch3	b	-	-	-	b	b	a	-	-	
	ch4	-	b	-	-	b	b	a	-	-	
Vref ON Voltage	ch1	-	-	-	b	b	b	a	-	-	
	ch2	-	-	b	-	b	b	a	-	-	
	ch3	b	-	-	-	b	b	a	-	-	
	ch4	-	b	-	-	b	b	a	-	-	
Vref OFF Voltage	ch1	-	-	-	b	b	b	a	-	-	
	ch2	-	-	b	-	b	b	a	-	-	
	ch3	b	-	-	-	b	b	a	-	-	
	ch4	-	b	-	-	b	b	a	-	-	
BREAK1 Brake Current	ch1	-	-	-	b	b	b	a	-	-	
PWM Sink Current		-	-	-	b	-	-	a	b	a	
HV _{cc} Level Shift Voltage		-	-	-	b	b	b	b	a	b	
HV _{cc} Leak Current		-	-	-	-	b	b	a	-	-	
PWM Amp Transfer Gain		-	-	-	b	b	b	a	-	-	

Item	SW No.	
	19	27
CHGSET Pin Bias Voltage	a	-
CHGSET Pin Output Resistance	b	-
SEL Pin Leak Current 1	-	a
SEL Pin Leak Current 2	a	a
SEL Pin Saturation Voltage	b	b

- : Turn off switch

Switching Position Table

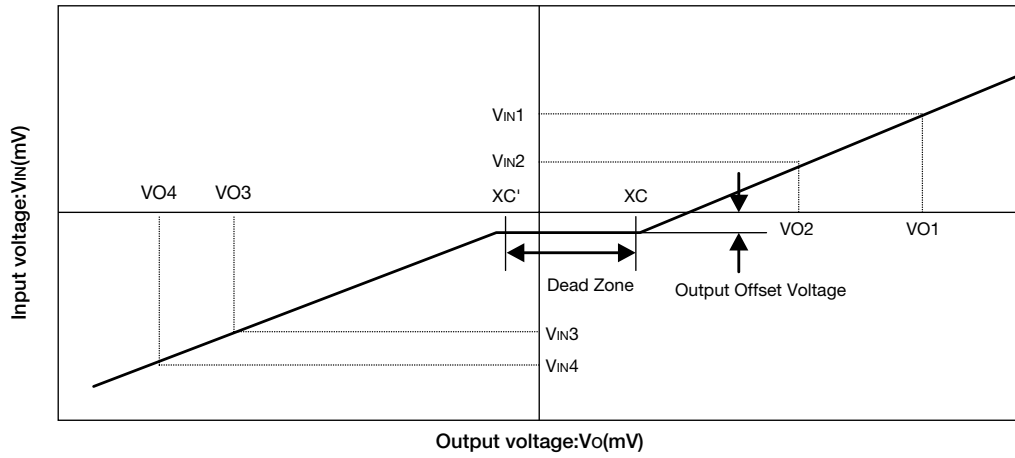

◎ Voltage Gain

$$G_{vc (+)} = 20 \log \frac{V_{O1} - V_{O2}}{V_{IN1} - V_{IN2}}$$

$$G_{vc (-)} = 20 \log \frac{V_{O3} - V_{O4}}{V_{IN3} - V_{IN4}}$$

◎ Gain Error By Polarity

$$G_{vc} = G_{vc (+)} - G_{vc (-)}$$

◎ Dead Zone

$$X_C - X_C' = \frac{V_{IN2} \cdot V_{O1} - V_{IN1} \cdot V_{O2}}{V_{O1} - V_{O2}} - \frac{V_{IN3} \cdot V_{O4} - V_{IN4} \cdot V_{O3}}{V_{O3} - V_{O4}}$$

Application Circuit

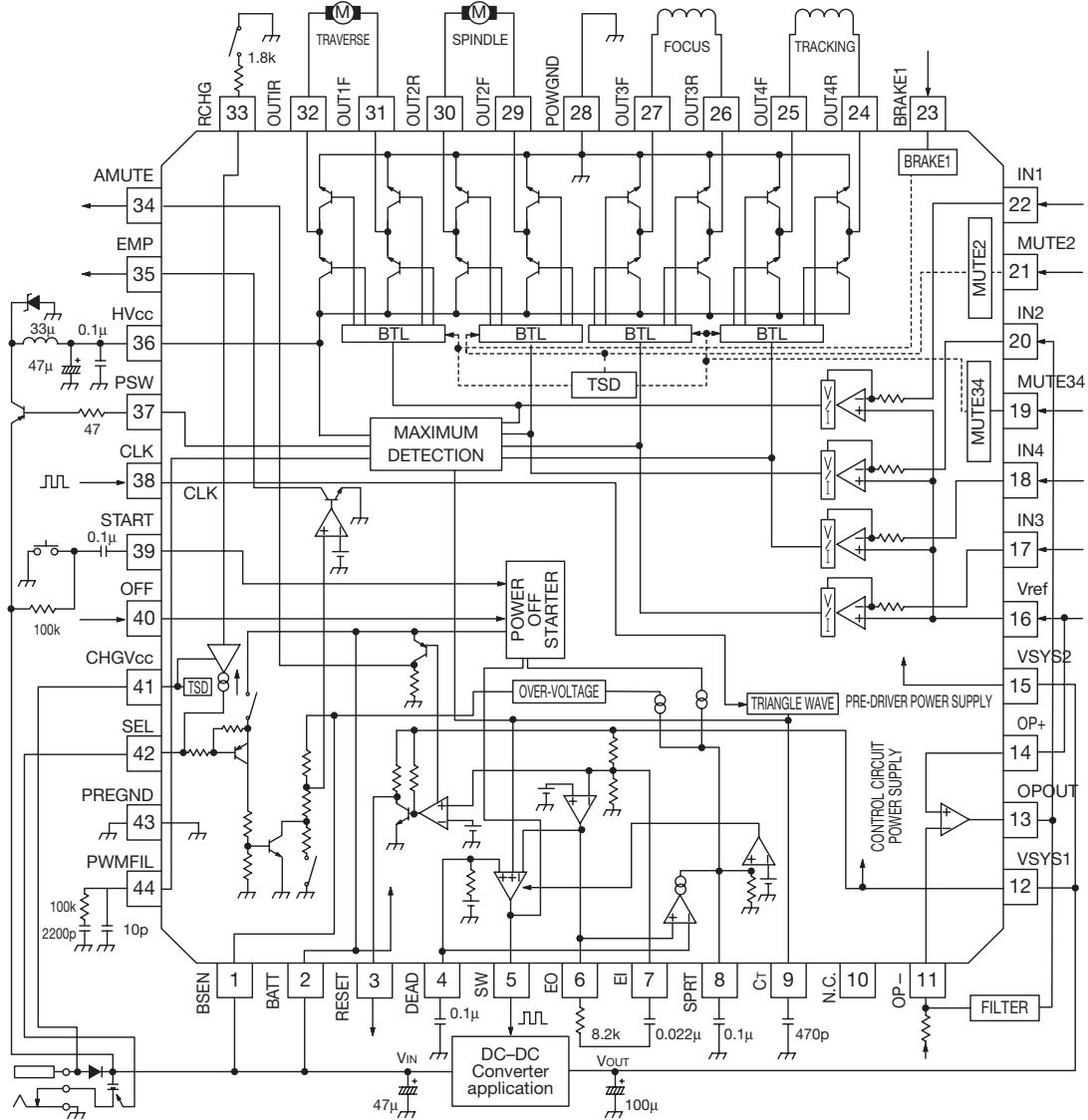

- We shall not be liable for any trouble or damage caused by using this circuit.
- In the event a problem which may affect industrial property or any other rights of us or a third party is encountered during the use of information described in these circuit, Mitsumi Electric Co., Ltd. shall not be liable for any such problem, nor grant a license therefor.

Circuit operation

1 H-bridge driver block

(1) Gain setting

- The driver input resistance (ch 1,3 and 4) are 11kΩ typ. ,ch2 is 7.5kΩ typ. . Set the gain according to the following formula.

ch1	GV=20log	$\frac{55k}{11k+R}$	(db)
ch2			
ch3			
ch2	GV=20log	$\frac{110k}{7.5k+R}$	(db)

R:Externally-connected input

- The driver output stage power supply is HVcc(36PIN), and the bridge circuit power supply is VSYS2 (15PIN). Connect a bypass capacitor between these two power supplies(approximately 0.1μF).

(2) Mute function

- Of the four drivers,ch1 has a brake function,and the other channels have a mute function.
- When BRAKE1(23PIN)is set to high level, both ch1 outputs go low level, and the circuit enters brake mode.
- When MUTE2(21PIN)is set to high level, the ch2 output is muted.
- When MUTE34(19PIN)is set to high level, the ch3 and 4 outputs are muted.

(3) Vref drop mute

- When the voltage applied to Vref(16PIN)is 1.0V or less typ. , the driver outputs are set to high impedance.

(4) Thermal shutdown

- When the chip temperature reaches 150°C typ. the output current is cut. The chip starts operating again at about 120°C typ. .

2 PWM power supply drive block

- This detects the maximum output level from among the four channels, and supplies the load drive power supply(36PIN)for the PWM. The external components are a PNP transistor, coil, Schottky diode,and capacitor.

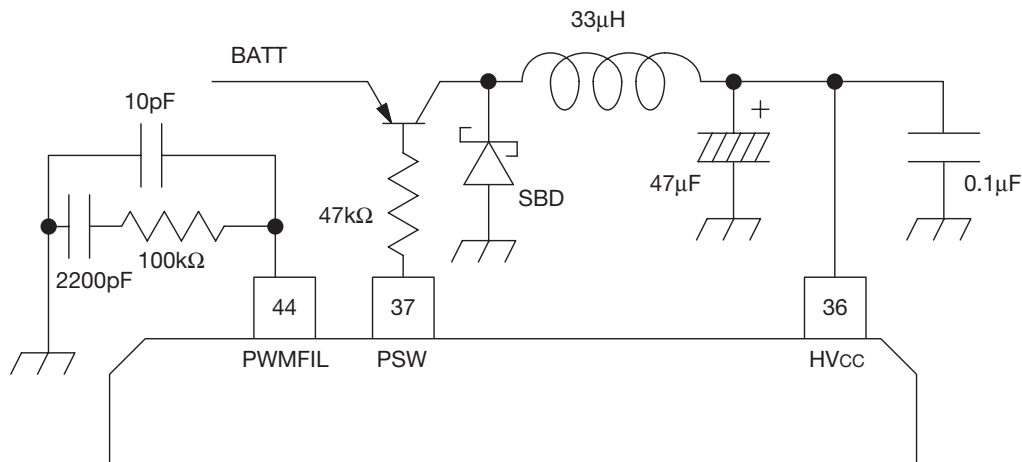

3 DC-DC converter block

(1) Output voltage

- 3.2V typ. voltage multiplier circuit can be constructed using external components. This voltage can be varied with the addition of an external resistor. The setting method is as follows.

$$V_{SYS1} = 1.2 \times \frac{\frac{R1 \cdot R3}{R1 + R3} + \frac{R2 \cdot R4}{R2 + R4}}{\frac{R2 \cdot R4}{R2 + R4}} \text{ (V)}$$

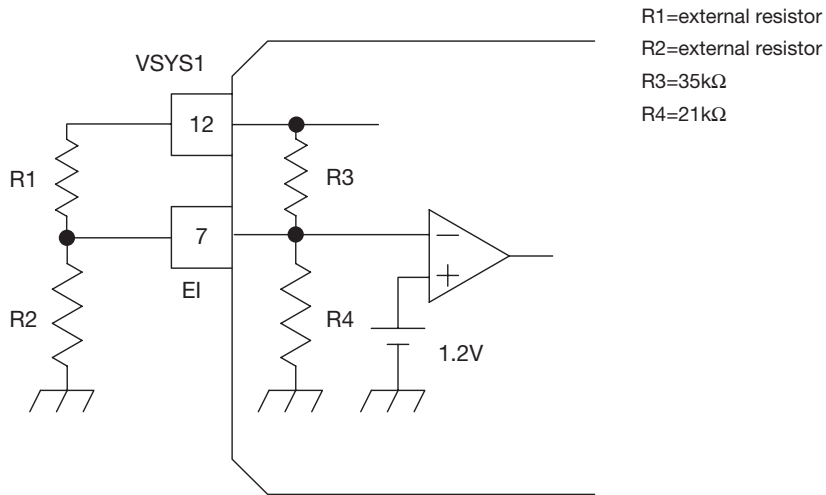

(2) Short protect function

- When the error amplifier output(6PIN)has switched to the high-level state,SPRT(8PIN)is charged, and when the voltage reaches 1.2V typ. , the SW(5PIN)switching stops.The time until switching stops is set by the capacitor connected to SPRT(8PIN)according to the following formula.

$$t = C_{SPRT} \times \frac{V_{TH}}{I_{SPRT}} \text{ (sec) } (V_{TH}=1.2V, I_{SPRT}=10\mu A)$$

(3) Soft start function

- The soft start function operates when a capacitor is connected between DEAD(4PIN)and GND. Also, the maximum duty can be varied by connecting a resistor to 4PIN.

$$t = C_{DEAD} \times R \text{ (sec) } (R=65k\Omega)$$

(4) Power off function

- When low-level is applied to OFF(40PIN), SPRT(8PIN)is charged, and when the voltage reaches 1.2V typ. , the SW(5PIN)switching stops. The time until switching stops is set by the capacitor connected to SPRT(8PIN)according to the following formula.

$$t = C_{SPRT} \times \frac{V_{TH}}{I_{OFF}} \text{ (sec) } (V_{TH}=1.2V, I_{OFF}=20\mu A)$$

(5) Over voltage protection circuit

- When the voltage applied to BSEN(1PIN)reaches 8.4V typ. , SPRT(8PIN)is charged, and when the voltage reaches 1.2V typ. , theSW(5PIN)switching stops. The time until switching stops is set by the capacitor connected to SPRT(8PIN)according to the following formula.

$$t = C_{SPRT} \times \frac{V_{TH}}{I_{HV}} \text{ (sec) } (V_{TH}=1.2V, I_{HV}=20\mu A)$$

4 Empty detector block

(1) Output voltage

- When the voltage applied to the BSEN(1PIN)falls below the detector voltage, EMP(35PIN)goes from high level to low level(open-collector output). The detector voltage has 50mV typ. of hysteresis to prevent output chattering. Use SEL(42PIN)to switch the detection voltage as shown below.

SEL	Detect Voltage	Return Voltage
L	2.20V typ.	2.25V typ.
High-Z	1.80V typ.	1.85V typ.

5 Reset circuit block

- At about 90% typ. of the DC-DC converter output voltage, RESET(3PIN)goes from low level to high level, and AMUTE(34PIN)goes from high level to low level. The reset voltage has 50mV typ. of hysteresis to prevent output chattering.

6 Charging circuit block

- The power supply for the charging circuit block is CHGV_{CC}(41PIN), and is independent from the other circuits.The resistance between RCHG(33PIN)and GND sets the charging current. This current is drawn from SEL(42PIN).
- A thermal shutdown circuit is provided,and when the chip temperature reaches 150°C typ. the charging current is cut. The chip starts operating again at about 120°C typ. .

Characteristics

Input Load Fluctuation

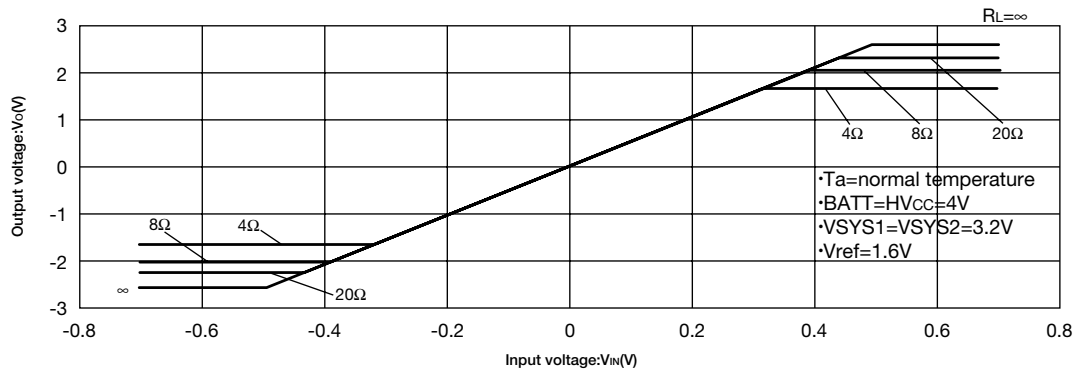

Input Load Fluctuation (ch2)

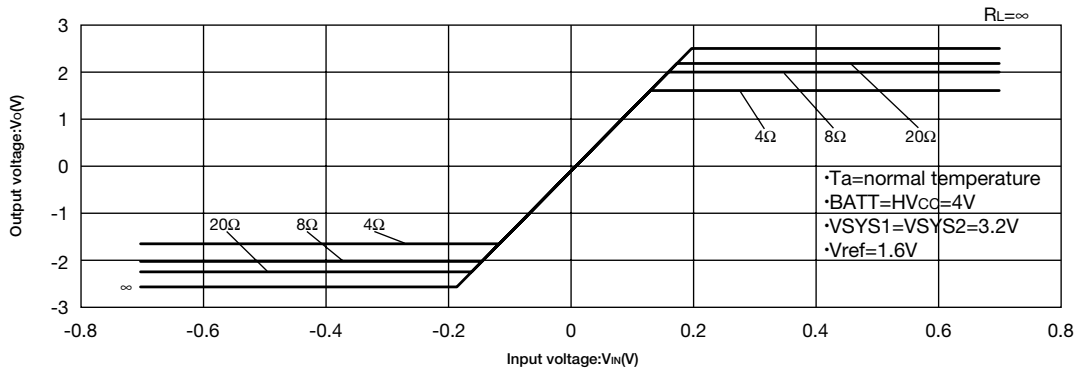

Daed Zone

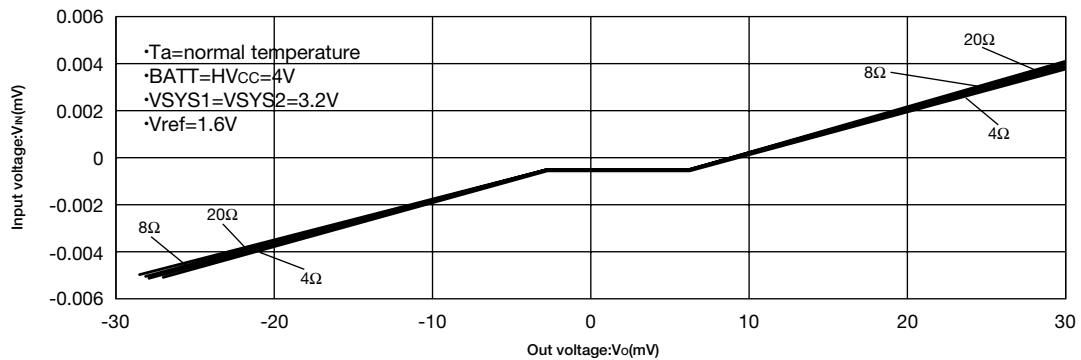

Characteristics

Error Amp Output Voltage

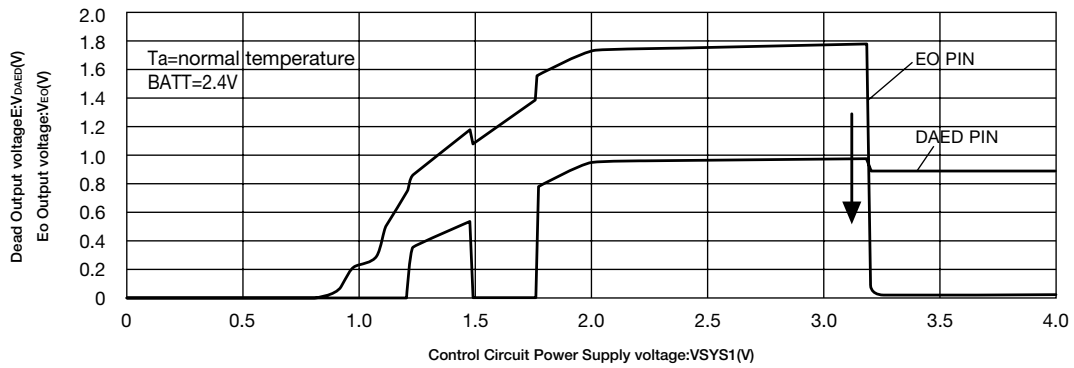

Resete Pin Voltage

