

---

# HD61602/HD61603

(Segment Type LCD Driver)

## HITACHI

---

### Description

The HD61602 and the HD61603 are liquid crystal display driver LSIs with a TTL and CMOS compatible interface. Each of the LSIs can be connected to various microprocessors.

The HD61602 incorporates the power supply circuit for the liquid crystal display driver. Using the software-controlled liquid crystal driving method, several types of liquid crystals can be connected according to the applications.

The HD61603 is a liquid crystal display driver LSI only for static drive and has 64 segment outputs that can display 8 digits per chip.

### Features

- Wide-range operating voltage
  - Operates in a wide range of supply voltage: 2.2V to 5.5V
  - Compatible with TTL interface at 4.5V to 5.5V
- Low current consumption
  - Can run from a battery power supply (100  $\mu$ A max. at 5 V)
  - Standby input enables standby operation at lower current consumption (5  $\mu$ A max. on 5V)
- Internal power supply circuit for liquid crystal display driver (HD61602)
  - Internal power supply circuit for liquid crystal display driver facilitates the connection to a microprocessor system

**Ordering Information**

Type No.	Package
HD61602R	80-pin plastic QFP (FP-80)
HD61602RH	80-pin plastic QFP (FP-80A)
HD61603R	80-pin plastic QFP (FP-80)

**Versatile Segment Driving Capacity**

Type No.	Driving Method	Display Segments	Example of Use	Frame Freq. (Hz) at $f_{osc} = 100$ kHz	Package
HD61602	Static	51	8 segments $\times$ 6 digits + 3 marks	33	80-pin plastic QFP (FP-80, FP-80A, TFP-80)
	1/2 bias 1/2 duty	102	8 segments $\times$ 12 digits + 6 marks	65	
	1/3 bias 1/3 duty	153	9 segments $\times$ 17 digits	208	
	1/4 bias 1/4 duty	204	8 segments $\times$ 25 digits + 4 marks	223	
HD61603	Static	64	8 segments $\times$ 8 digits	33	80-pin plastic QFP (FP-80)

# HD61602/HD61603

## Pin Arrangement

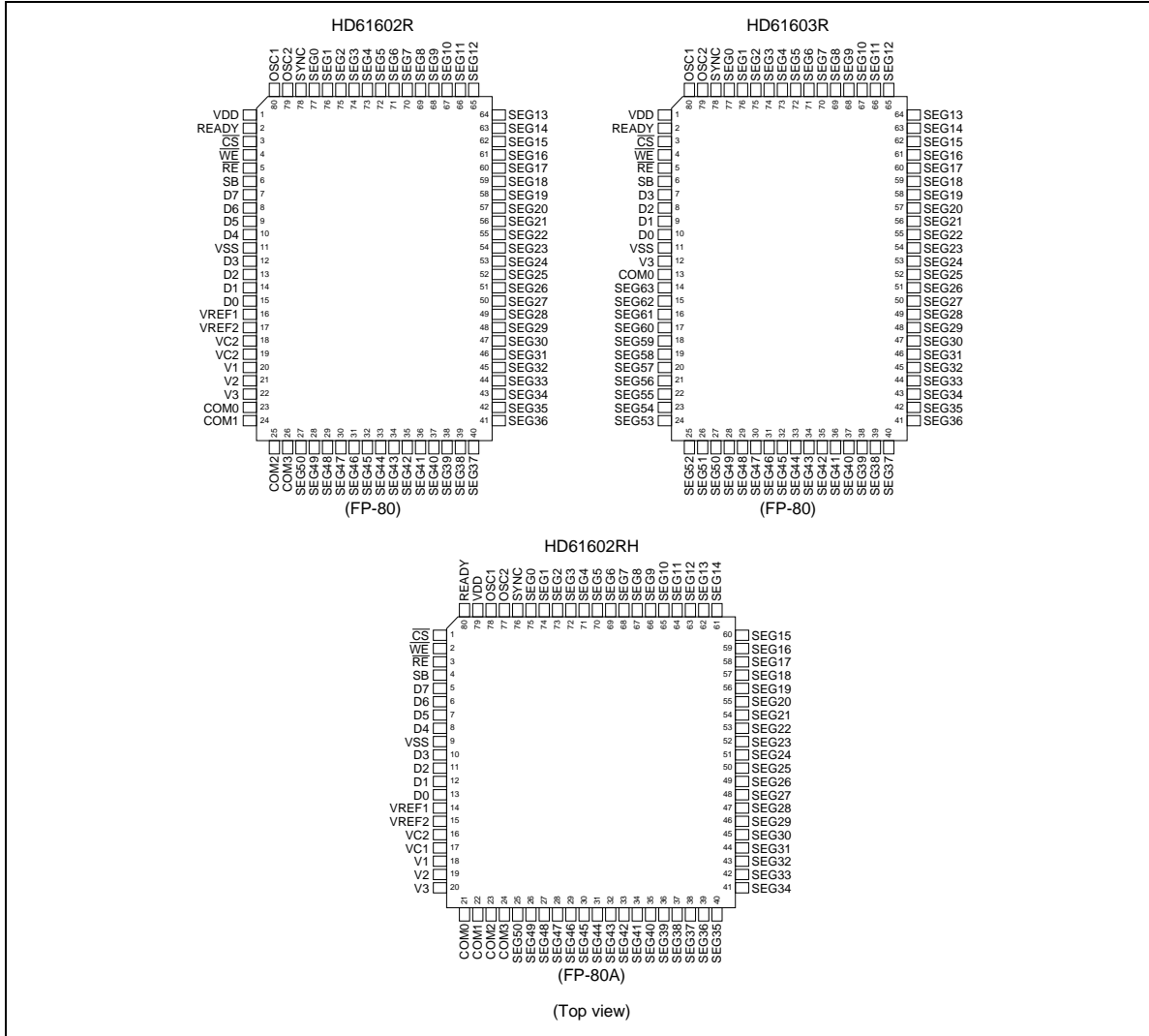

Block Diagram

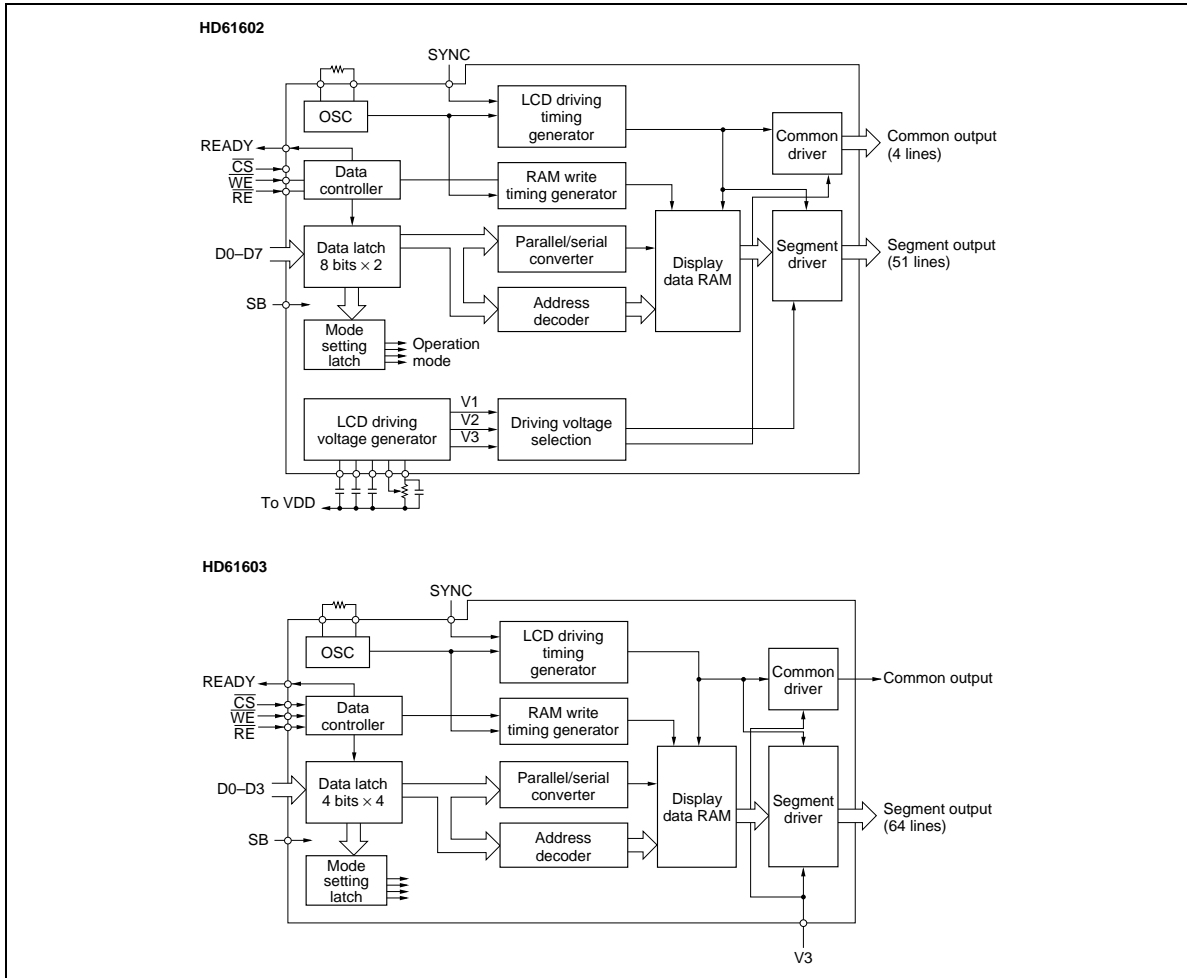

## HD61602/HD61603

### Terminal Functions

#### HD61602 Terminal Functions

Terminal Name	No. of Lines	Input/Output	Connected to	Function
VDD	1	Power supply		Positive power supply.
READY	1	NMOS open drain output	MCU	While data is being set in the display data RAM and mode setting latch in the LSI after data transfer, low is output from the READY terminal to inhibit the next data input. There are two modes: one in which low is output only when both of $\overline{CS}$ and $\overline{RE}$ are low, and the other in which low is output regardless of $\overline{CS}$ and $\overline{RE}$ .
$\overline{CS}$	1	Input	MCU	Chip select input. Data can be written only when this terminal is low.
$\overline{WE}$	1	Input	MCU	Write enable input. Input data of D0 to D7 is latched at the rising edge of $\overline{WE}$ .
$\overline{RE}$	1	Input	MCU	Resets the input data byte counter. After both $\overline{CS}$ and $\overline{RE}$ are low, the first data is recognized as the 1st byte data.
SB	1	Input	MCU	High level input stops LSI operations. 1. Stops oscillation and clock input. 2. Stops LCD driver. 3. Stops writing data into display RAM.
D0–D7	8	Input	MCU	Data input terminal for 8-bit × 2-byte data.
VSS	1	Power supply		Negative power supply.
VREF1	1	Output	External R	Reference voltage output. Generates LCD driving voltage.
VREF2	1	Input	External R	Divides the reference voltage of VREF1 with external R to determine LCD driving voltage. $VREF2 \approx V1$ .
VC1, VC2	2	Output	External C	Connection terminals for boosting C of LCD driving voltage generator. An external C is connected between VC1 and VC2.
V1, V2, V3	3	Output (Input)	External C	LCD driving voltage outputs. An external C is connected to each terminal.
COM0–COM3	4	Output	LCD	LCD common (backplate) driving output.
SEG0–SEG50	51	Output	LCD	LCD segment driving output.
SYNC	1	Input	MCU	Synchronous input for 2 or more chips applications. LCD driver timing circuit is reset by high input. LCD is off.
OSC1 OSC2	2	Input Output	External R	Attach external R to these terminals for oscillation. An external clock (100 kHz) can be input to OSC1.

Note: Logic polarity is positive. 1 = high = active.

**HD61603 Terminal Functions**

Terminal Name	No. of Lines	Input/Output	Connected to	Function
VDD	1	Power supply		Positive power supply.
READY	1	NMOS open drain output	MCU	While data is being set in the display data RAM and mode setting latch in the LSI after data transfer, low is output from the READY terminal to inhibit the next data input. There are two modes: one in which low is output only when both of $\overline{CS}$ and $\overline{RE}$ are low, and the other in which low is output regardless of $\overline{CS}$ and $\overline{RE}$ .
$\overline{CS}$	1	Input	MCU	Chip select input. Data can be written only when this terminal is low.
$\overline{WE}$	1	Input	MCU	Write enable input. Input data of D0 to D3 is latched at the rising edge of $\overline{WE}$ .
$\overline{RE}$	1	Input	MCU	Resets the input data byte counter. After both of $\overline{CS}$ and $\overline{RE}$ are low, the first data is recognized as the 1st byte data.
SB	1	Input	MCU	High level input stops the LSI operations. 1. Stops oscillation and clock input. 2. Stops LCD driver. 3. Stops writing data into display RAM.
D0–D3	4	Input	MCU	Data input terminal from where 4-bit × 4 data are input.
VSS	1	Power supply		Negative power supply.
V3	1	Input	Power supply	Power supply input for LCD drive. Voltage between VDD and V3 is used as driving voltage.
COM0	1	Output	LCD	LCD common (backplate) driving output.
SEG0–SEG63	64	Output	LCD	LCD segment driving output.
SYNC	1	Input	MCU	Synchronous input for 2 or more chips applications. LCD driver timing circuit is reset by high input. LCD is off.
OSC1 OSC2	2	Input Output	External R	Attach external R to these terminals for oscillation. An external clock (100 kHz) can be input to OSC <sub>1</sub> .

Note: Logic polarity is positive. 1 = high = active.

---

## HD61602/HD61603

---

### Display RAM

#### HD61602 Display RAM

The HD61602 has an internal display RAM shown in Figure 1. Display data is stored in the RAM, or is read according to the LCD driving timing to display on the LCD. One bit of the RAM corresponds to 1 segment of the LCD. Note that some bits of the RAM cannot be displayed depending on LCD driving mode.

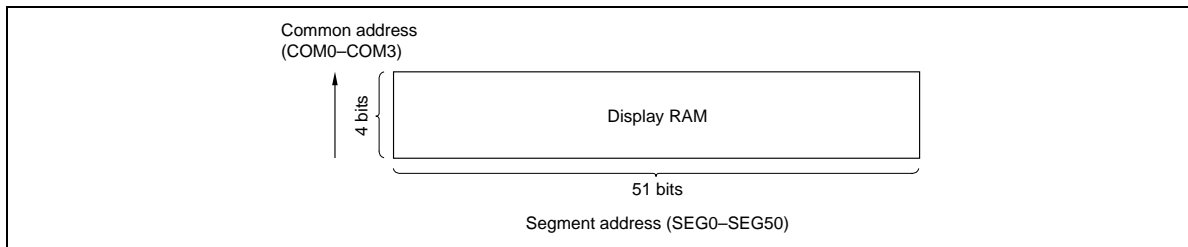

**Figure 1 Display RAM**

**Reading Data from Display RAM:** A display RAM segment address corresponds to a segment output. The data at segment address SEGn is output to segment output SEGn terminal.

A common address corresponds to the output timing of a common output and a segment output. The same common address data is simultaneously read. The data of display RAM is reproduced on the LCD panel.

When a 7-segment type LCD driver is connected, for example, the correspondence between the display RAM and the display pattern in each mode is as follows:

1. Static drive

In the static drive, only the column of COM0 of display RAM is output. COM1 to COM3 are not displayed (Figure 2).

2. 1/2 duty cycle drive

In the 1/2 duty cycle drive, the columns of COM0 and COM1 of display RAM are output in time sharing. The columns of COM2 and COM3 are not displayed (Figure 3).

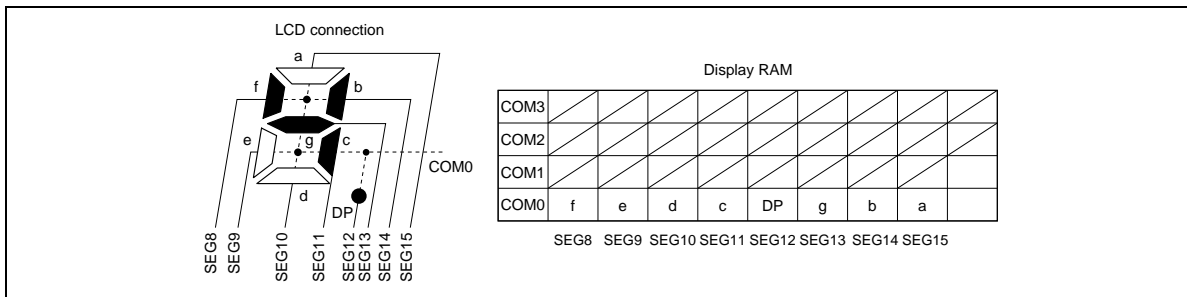

Figure 2 Example of Correspondence between LCD Connection and Display RAM (Static Drive, HD61602)

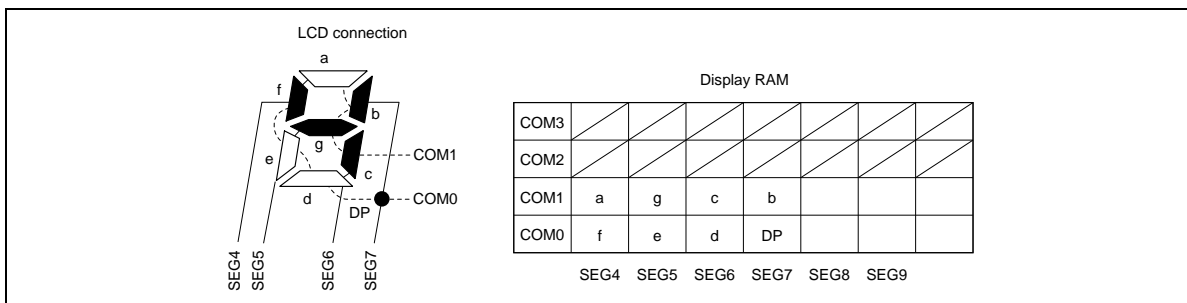

Figure 3 Example of Correspondence between LCD Connection and Display RAM (1/2 Duty Cycle, HD61602)



## HD61602/HD61603

### 3. 1/3 duty cycle drive

In the 1/3 duty cycle drive, the columns of COM0 to COM2 are output in time sharing. No column of COM3 is displayed.

“Y” cannot be rewritten by display data (input on an 8-segment basis). Please use bit manipulation to turn on/off the display of “Y” (Figure 4).

### 4. 1/4 duty cycle drive

In the 1/4 duty cycle drive, all the columns of COM0 to COM3 are displayed (Figure 5).

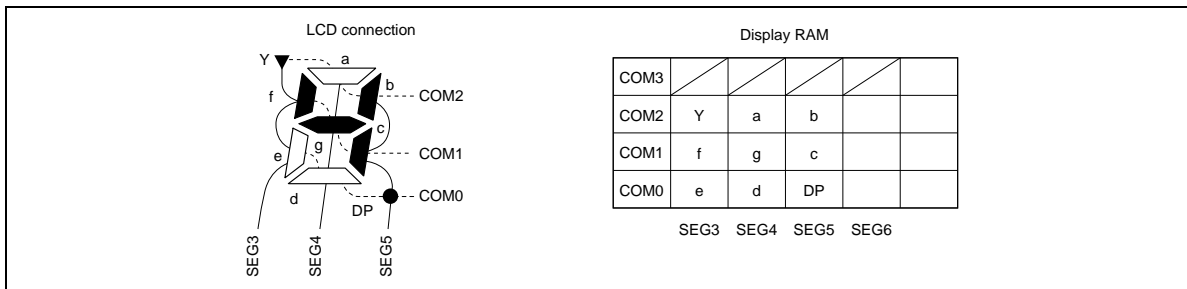

**Figure 4 Example of Correspondence between LCD Connection and Display RAM (1/3 Duty Cycle, HD61602)**

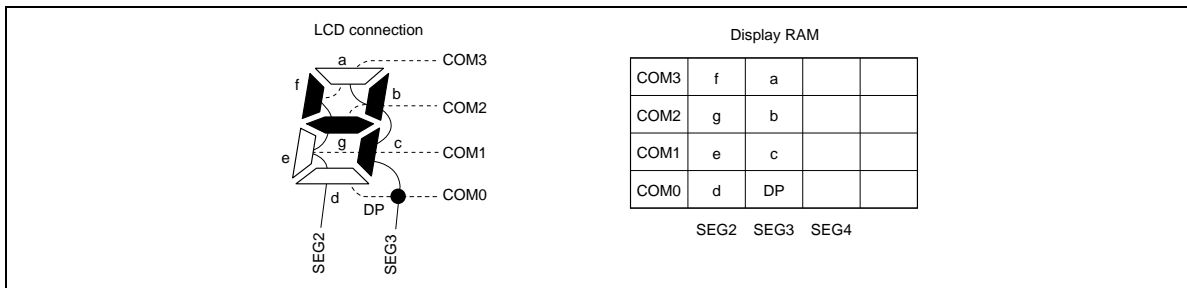

**Figure 5 Example of Correspondence between LCD Connection and Display RAM (1/4 Duty Cycle, HD61602)**

**Writing Data into Display RAM:** Data is written into the display RAM in the following five methods:

1. Bit manipulation  
Data is written into any bit of RAM on a bit basis.
2. Static display mode  
8-bit data is written on a digit basis according to the 7-segment type LCD pattern of static drive.
3. 1/2 duty cycle display mode  
8-bit data is written on a digit basis according to the 7-segment type LCD pattern of 1/2 duty cycle drive.
4. 1/3 duty cycle display mode  
8-bit data is written on a digit basis according to the 7-segment type LCD pattern of 1/3 duty cycle drive.
5. 1/4 duty cycle display mode  
8-bit data is written on a digit basis according to the 7-segment type LCD pattern of 1/4 duty cycle drive.

The RAM area and the allocation of the segment data for 1-digit display depend on the driving methods as described in “Reading Data from Display RAM”.

8-bit data is written on a digit basis corresponding to the above duty cycle driving methods. The digits are allocated as shown Figure 8 (allocation of digits). As the data can be transferred on a digit basis from a microprocessor, transfer efficiency is improved by allocating the LCD pattern according to the allocation of each bit data of the digit in the data RAM.

Figure 6 shows the digit address (displayed as Adn) to specify the store address of the transferred 8-bit data on a digit basis.

Figure 7 shows the correspondence between each segment in an Adn and the 8-bit input data.

When data is transferred on a digit basis 8-bit display data and digit address should be specified as described above.

However, when the digit address is Ad6 for static, Ad12 for 1/2 duty cycle, or Ad25 for 1/4 duty cycle, display RAM does not have enough bits for the data.

Thus the extra bits of the input 8-bit data are ignored.

In bit manipulation, any one bit of display RAM can be written. When data is transferred on a bit basis, 1-bit display data, a segment address (6 bits) and a common address (2 bits) should be specified.

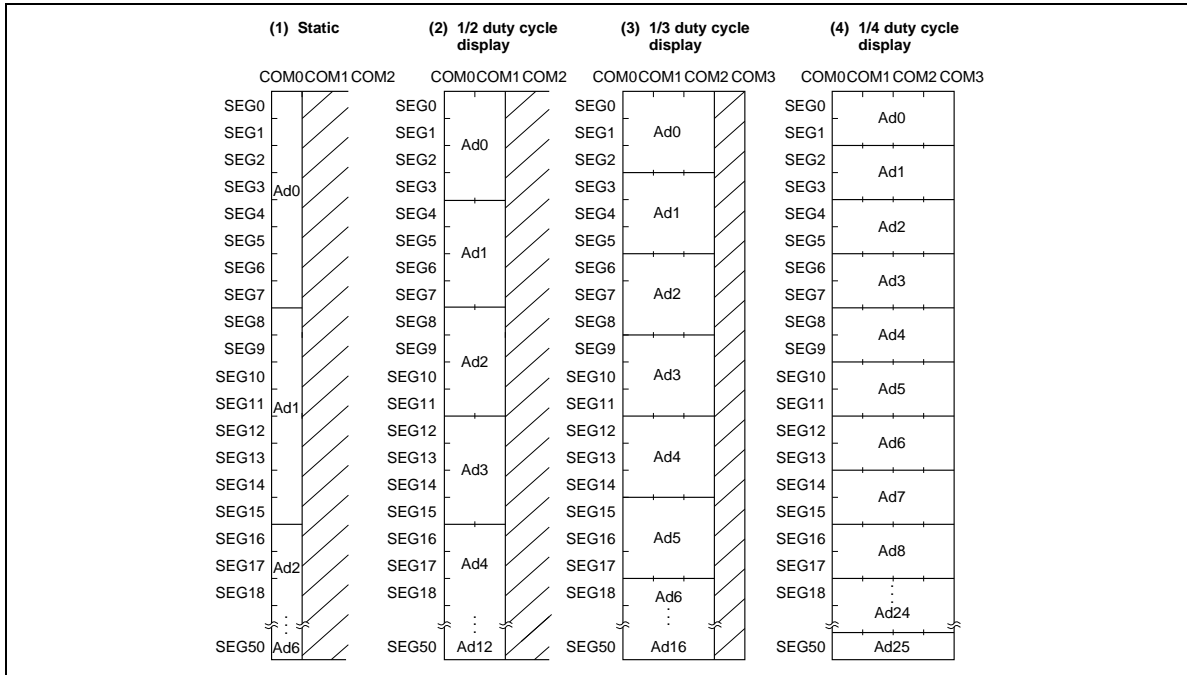

**Figure 6 Allocation of Digit (HD61602)**

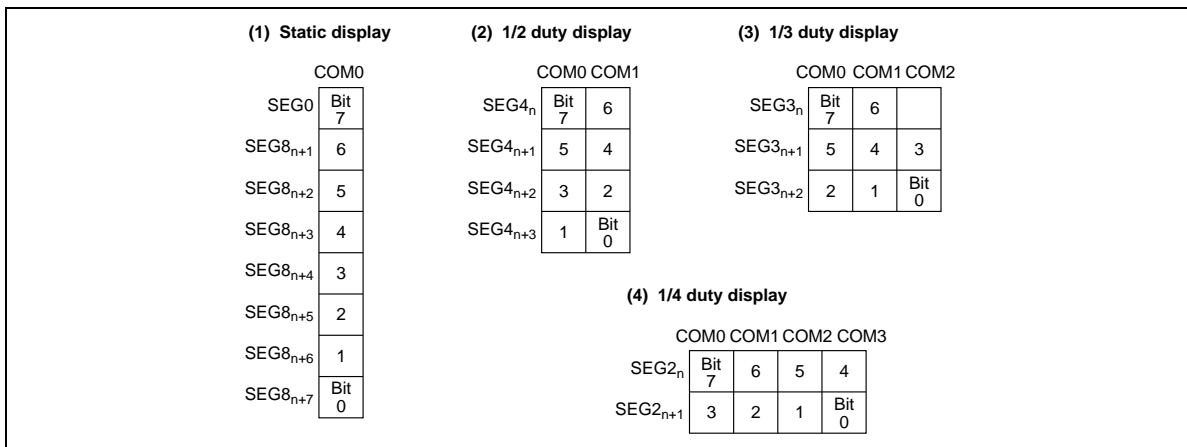

**Figure 7 Bit Assignment in an Adn (HD61602)**

**HD61603 Display RAM**

The HD61603 has an internal display RAM as shown in Figure 8. Display data is stored in the RAM and output to the segment output terminal.

**Reading Data from Display RAM:** Each bit of the display RAM corresponds to an LCD segment. The data at segment address SEGn is output to segment output SEGn terminal. Figure 9 shows an example of the correspondence between the display RAM bit and the display pattern when a 7-segment type LCD is connected.

**Writing Data into Display RAM:** Data is written into the display RAM in the following two methods:

1. Bit manipulation  
Data is written into any bit of RAM on a bit basis.
2. Static display mode  
8-bit data is written on a digit basis according to the 7-segment type LCD pattern of static drive.

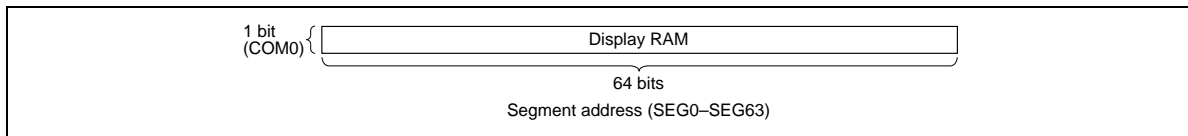

**Figure 8 Display RAM (HD61603)**

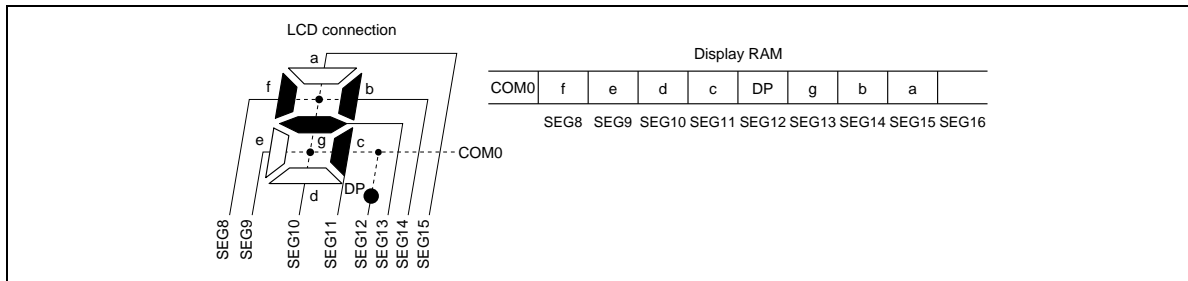

**Figure 9 Example of Correspondence between Display RAM Bit and Display Pattern (HD61603)**

---

## HD61602/HD61603

---

The 8-bit data is written on a digit basis into the digit address (displayed as Ad<sub>n</sub>) shown in Figure 10. When data is transferred from a microprocessor, four 4-bit data are needed to specify the digit address and an 8-bit display data. Figure 11 shows the correspondence between each segment in an Ad<sub>n</sub> and the transferred 8-bit data.

In bit manipulation, any one bit of display RAM can be written. When data is transferred on a bit basis, 1-bit display data and a segment address (6 bits) should be specified.

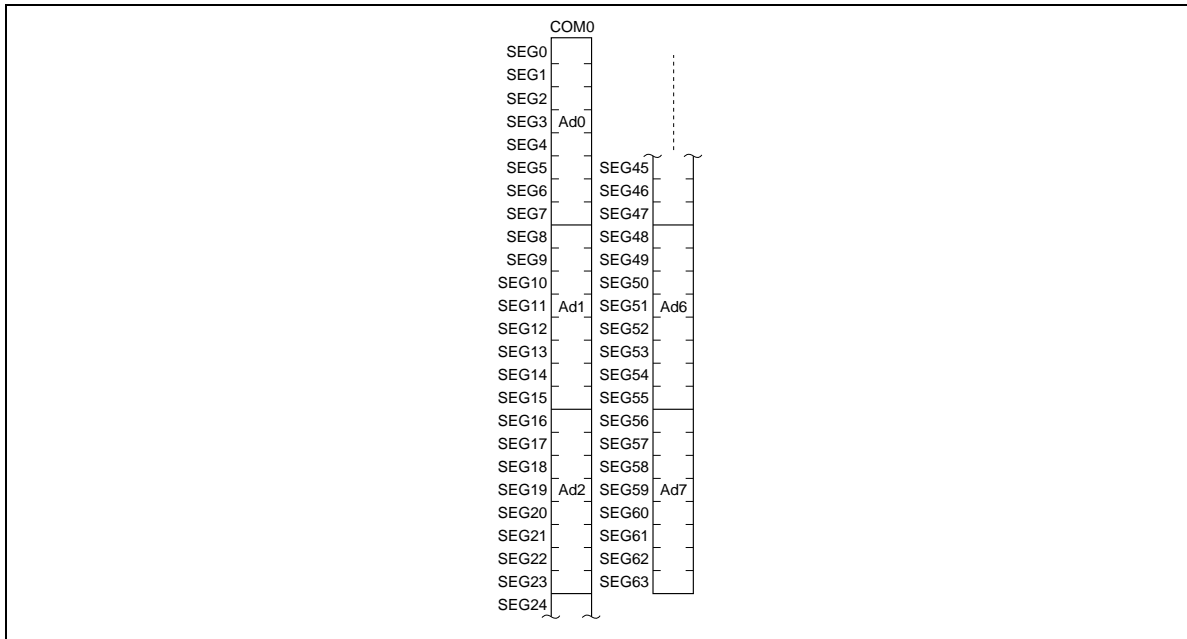

**Figure 10 Allocation of Digits (HD61603)**

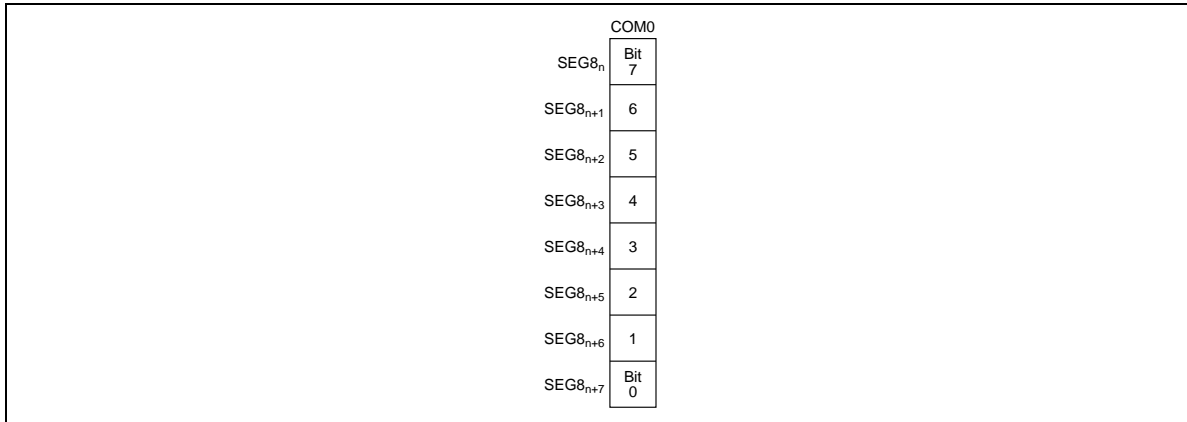

**Figure 11 Bit Assignment in an Adn (HD61603)**

### Operating Modes

#### HD61602 Operating Modes

The HD61602 has the following operating modes:

1. LCD drive mode  
Determines the LCD driving method.
  - a. Static drive mode  
LCD is driven statically.
  - b. 1/2 duty cycle drive mode  
LCD is driven at 1/2 duty cycle and 1/2 bias.
  - c. 1/3 duty cycle drive mode  
LCD is driven at 1/3 duty cycle and 1/3 bias.
  - d. 1/4 duty cycle drive mode  
LCD is driven at 1/4 duty cycle and 1/3 bias.
2. Data display mode  
Determines how to write display data into the data RAM.
  - a. Static display mode  
8-bit data is written into the display RAM according to the digit in static drive.
  - b. 1/2 duty cycle display mode  
8-bit data is written into the display RAM according to the digit in 1/2 duty cycle drive.
  - c. 1/3 duty cycle display mode  
8-bit data is written into the display RAM according to the digit in 1/3 duty cycle drive.
  - d. 1/4 duty cycle display mode  
8-bit data is written into the display RAM according to the digit in 1/4 duty cycle drive.
3. READY output mode  
Determines the READY output timing.  
After a data set is transferred, the data is processed internally. The next data cannot be acknowledged during the processing period. The READY output reports the period to the MPU. The timing when the READY is output can be selected from the following two modes:
  - a. READY is mode always available (Figure 12).
  - b. READY is mode available by  $\overline{\text{CS}}$  and  $\overline{\text{RE}}$  (Figure 13).
4. LCD OFF mode  
In this mode, the HD61602 stops driving LCD and turns it off.
5. External driving voltage mode  
A mode for using external driving voltage (V1, V2, and V3).

The above 5 modes are specified by mode setting data. The modes are independent of each other and can be used in any combination. Bit manipulation is independent of data display mode and can be used regardless of it.

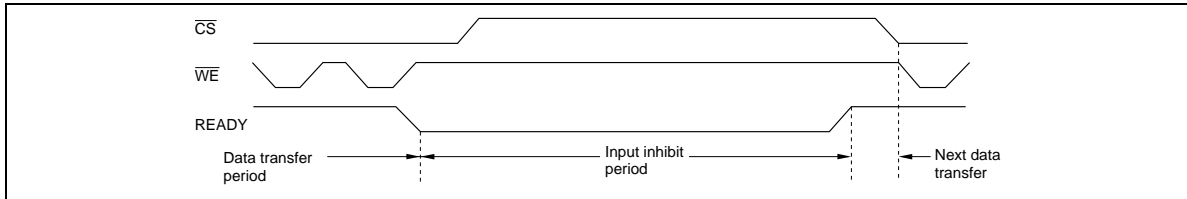

**Figure 12 READY Output Timing (When It Is Always Available)**

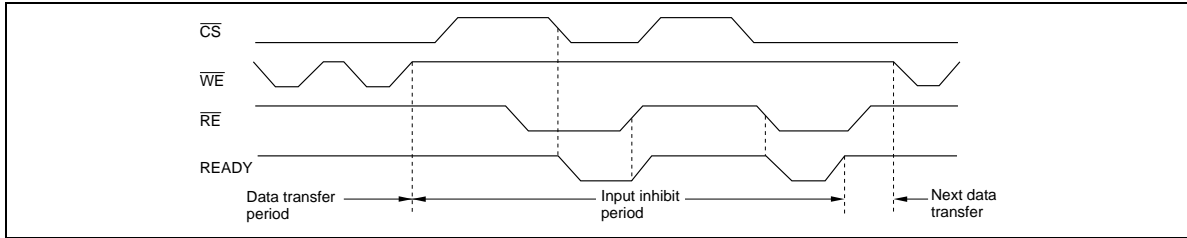

**Figure 13 READY Output Timing (When It Is Made Available by  $\overline{CS}$  and  $\overline{RE}$ )**



---

## HD61602/HD61603

---

### HD61603 Operating Modes

The HD61603 has the following modes:

1. READY output mode

Determines the READY output timing.

After a data set is transferred, the data is processed internally. The next data cannot be acknowledged during the processing period. The READY output reports the period to the MPU. The timing when READY is output can be selected from the following two modes:

- a. READY is always available (Figure 14).
- b. READY is mode available by  $\overline{CS}$  and  $\overline{RE}$  (Figure 15).

2. LCD OFF mode

In this mode, the HD61603 stops driving the LCD and turns it off.

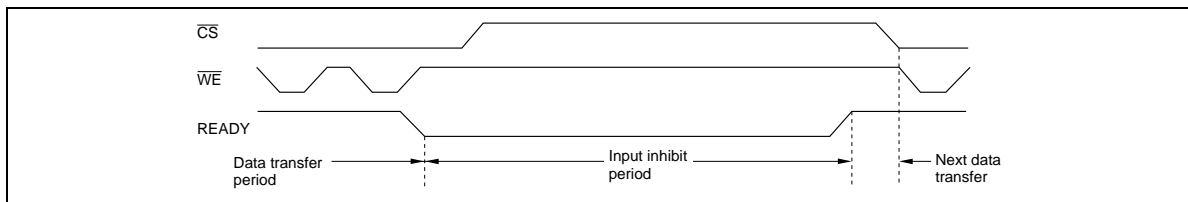

**Figure 14** READY Output Timing (When It Is Always Available)

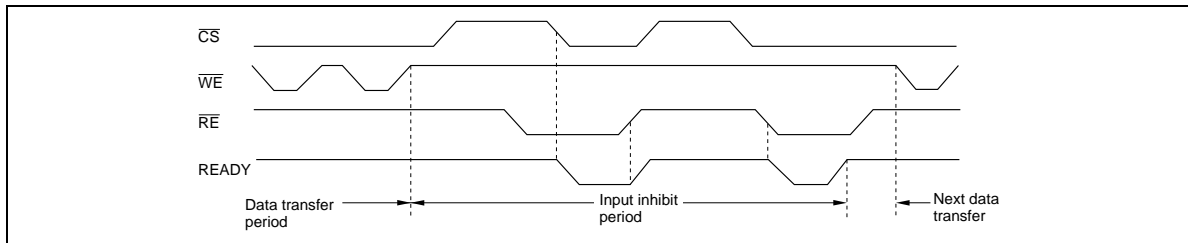

**Figure 15** READY Output Timing (When It Is Made Available by  $\overline{CS}$  and  $\overline{RE}$ )

## Input Data Formats

### HD61602 Input Data Formats

Input data is composed of 8 bits  $\times$  2. Input them as 2-byte data after READY output changes from low to high or low pulse is entered into RE terminal.

1. Display data (updates display on an 8-segment basis)

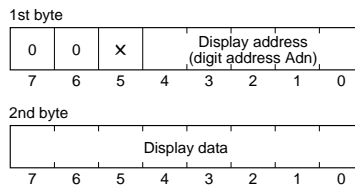

- a. Display address  
Digit address Adn in accordance with display mode
  - b. Display data  
Pattern data that is written into the display RAM according to display mode and the address
2. Bit manipulation data (updates display on a segment basis)



- a. Display data  
Data that is written into 1 bit of the specified display RAM.
- b. COM address  
Common address of display RAM
- c. SEG address  
Segment address of display RAM

---

## HD61602/HD61603

---

### 3. Mode setting data

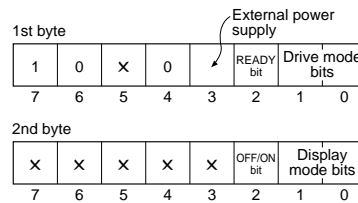

- a. Display mode bits
    - 00: Static display mode
    - 01: 1/2 duty cycle display mode
    - 10: 1/3 duty cycle display mode
    - 11: 1/4 duty cycle display mode
  - b. OFF/ON bit
    - 1: LCD off (set to 1 when SYNC is entered)
    - 0: LCD on
  - c. Drive mode bits
    - 00: Static drive
    - 01: 1/2 duty cycle drive
    - 10: 1/3 duty cycle drive
    - 11: 1/4 duty cycle drive
  - d. READY bit
    - 0: READY bus mode; READY outputs 0 only while CS and RE are 0. (reset to 0 when SYNC is entered)
    - 1: READY port mode; READY outputs 0 regardless of CS and RE.
  - e. External power supply bit
    - 0: Driving voltage is generated internally.
    - 1: Driving voltage is supplied externally. (Set to 1 when SYNC is entered.)
4. 1-byte instruction

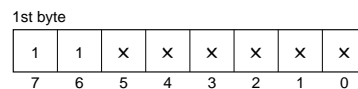

The first data (first byte) is ignored when bit 6 and bit 7 in the byte are 1.

### HD61603 Input Data Formats

Input data is composed of 4 bits  $\times$  4. Input them as four 4-bit data after READY output changes from low to high or low pulse is entered into RE terminal.

1. Display data (updates display on an 8-segment basis)

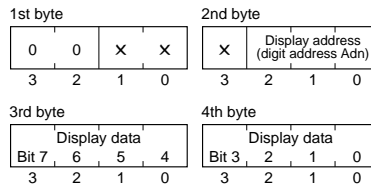

- a. Display address  
Digit address Adn shown in Figure 10.
- b. Display data  
Pattern data that is written into the display RAM as shown in Figure 11.

2. Bit manipulation data (updates display on a segment basis)

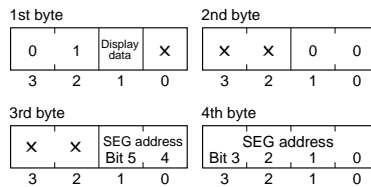

- a. Display data  
Data that is written into 1 bit of the specified display RAM.
- b. SEG address  
Segment address of display RAM (segment output)

---

## HD61602/HD61603

---

### 3. Mode setting data



a. OFF/ON bit

1: LCD off (set to 1 when SYNC is entered.)

0: LCD on

b. READY bits

0: READY bus mode; READY outputs 0 only while  $\overline{CS}$  and  $\overline{RE}$  are 0. (reset to 0 when SYNC is entered.)

1: READY port mode; READY outputs 0 regardless of  $\overline{CS}$  and  $\overline{RE}$ .

### 4. 1-byte instruction

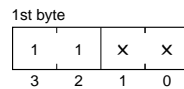

The first data (4 bits) is ignored when bit 3 and 2 in the data are 1.

## How to Input Data

### How to Input HD61602 Data

Input data is composed of 8 bits × 2. Take care that the data transfer is not interrupted, because the first 8-bit data is distinguished from the second one by the sequence only.

If data transfer is interrupted, or at power on, the following two methods can be used to reset the count of the number of bytes (count of the first and second bytes):

1. Set  $\overline{CS}$  and  $\overline{RE}$  inputs low (no display data changes).
2. Input 2 or more “1-byte instruction” data in which bit 7 and 6 are 1 (display data may change).

The data input method via data input terminals ( $\overline{CS}$ ,  $\overline{WE}$ , D0 to D7) is similar to that of static RAM such as HM6116. An access of the LSI can be made through the same bus line as ROM and RAM. When output ports of a microprocessor are used for an access, refer to the timing specifications and Figure 16.

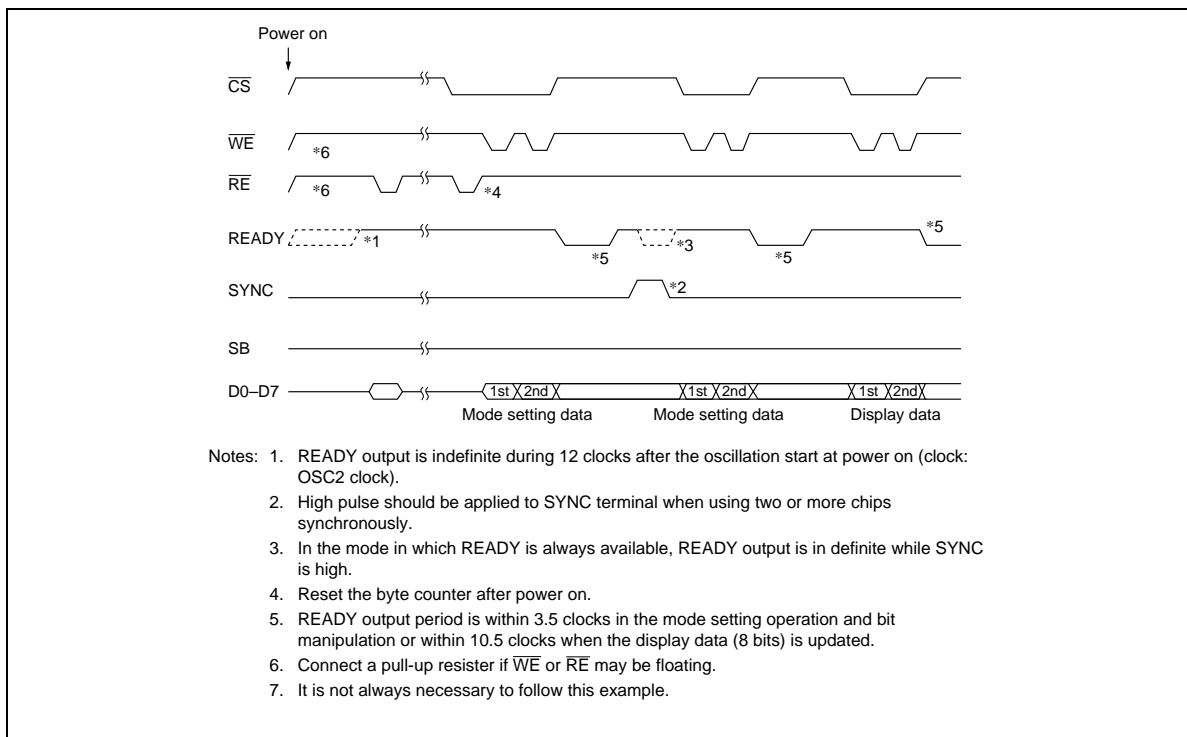

Figure 16 Example of Data Transfer Sequence

## HD61602/HD61603

### How to Input HD61603 Data

Input data is composed of 4 bits  $\times$  4. Take care that data transfer is not interrupted, because the first 4-bit data to the fourth 4-bit data are distinguished from each other by the sequence only.

If data transfer is interrupted, or at power on, the following two methods can be used to reset the count of the number of data (count of the first 4-bit data to the fourth 4-bit data):

1. Set  $\overline{\text{CS}}$  and  $\overline{\text{RE}}$  low.
2. Input 4 or more "1-byte instruction" data (4-bit data) in which bit 3 and 2 are 1 (display data may change).

The data input method via data input terminals ( $\overline{\text{CS}}$ ,  $\overline{\text{WE}}$ , D0 to D3) is similar to that of static RAM such as HM6116. An access of the LSI can be made through the same bus line as ROM and RAM. When output ports of a microprocessor are used for an access, refer to the timing specifications and Figure 17.

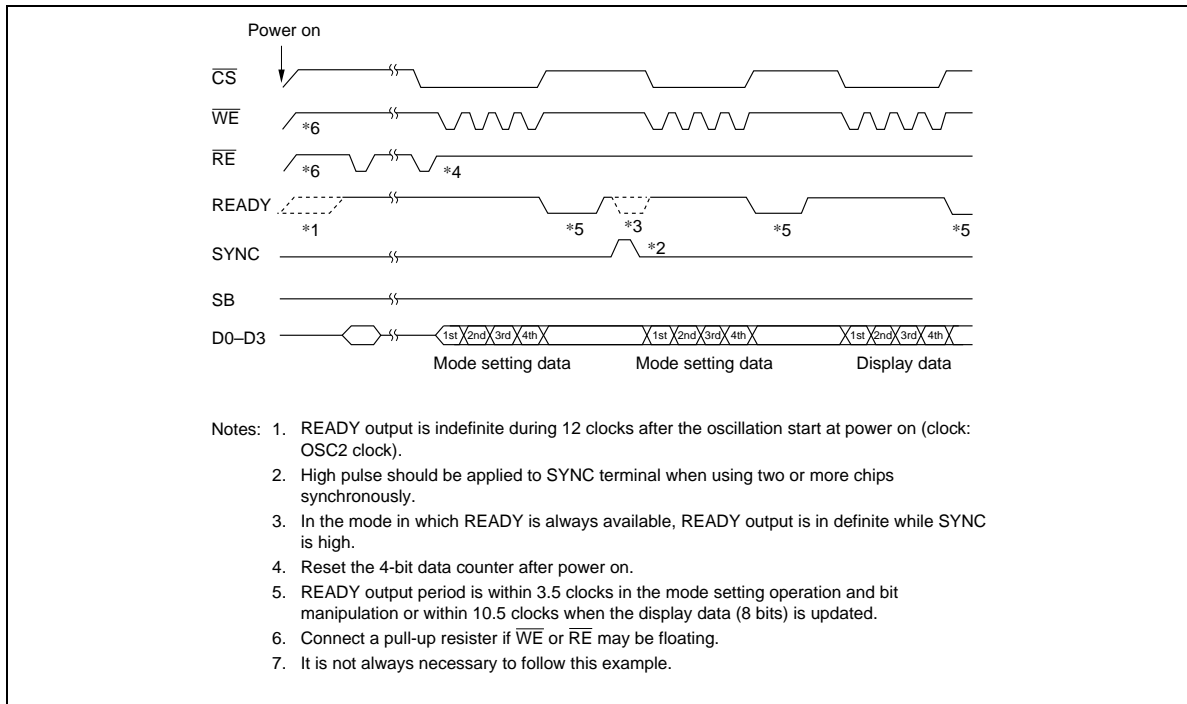

Figure 17 Example of Data Transfer Sequence

**Notes on READY Output**

Note that the READY output will be unsettled during 1.5 clocks (max) after inputting the first 2-byte data for setting the mode after turning the power on. This is because the READY bit data of mode setting latches and the mode of READY pin (READY bus or port mode) are unsettled until the completion of mode setting.

There are two kinds of the READY output waveforms depending of the modes:

1. READY bus mode (READY bit = 0)
2. READY port mode (READY bit = 1)

However, if you input SYNC before mode setting, waveform will be determined; when you choose READY bus mode, (1) a in Figure 18 will be output, and when you choose READY port mode, (2) a will be output. The figures can be applied both to HD61602 and HD61603.

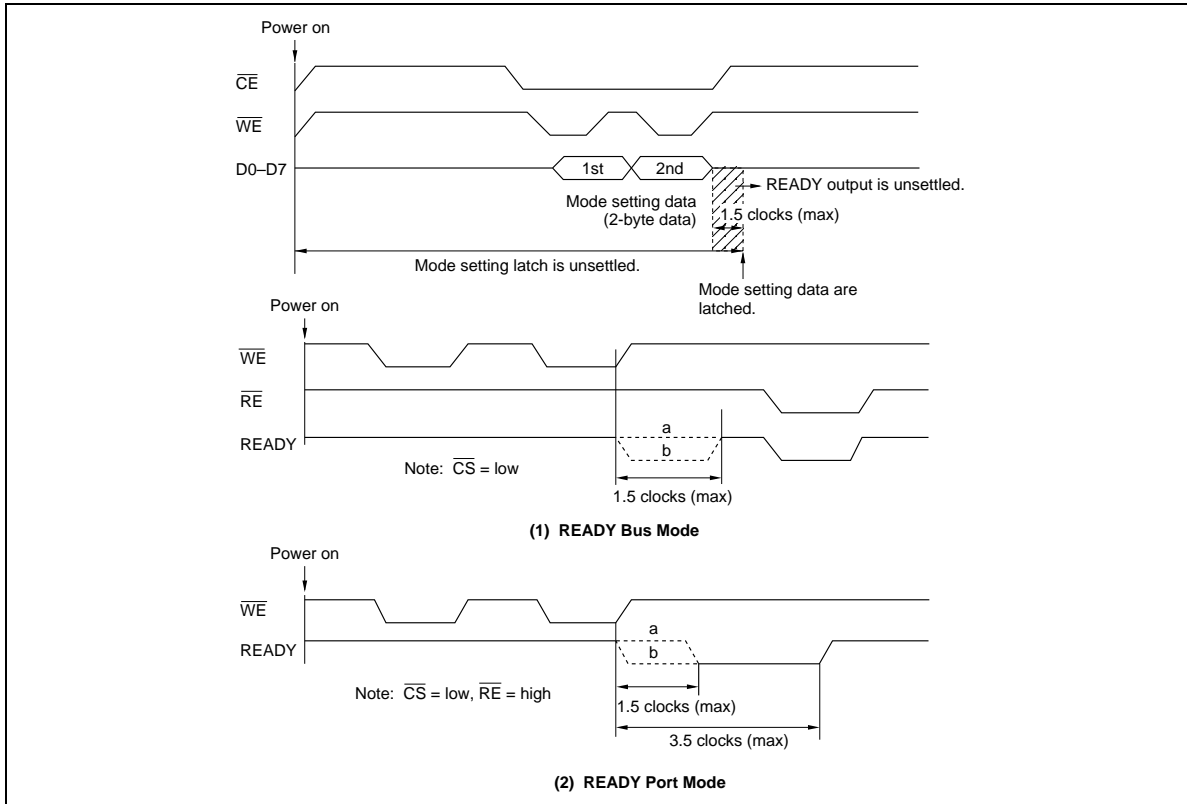

**Figure 18 READY Output According to Modes**



### **Standby Operation**

Standby operation with low power consumption can be activated when pin SB is used. Normal operation of the LSI is activated when pin SB is low level, and the LSI goes into the standby state when pin SB is high level. The standby state of the LSI is as follows:

1. LCD driver is stopped (LCD is off).
2. Display data and operating mode are held.
3. The operation is suspended while display changes (while READY is outputting low.) In this case, READY outputs high within 10.5 clocks or 3.5 clocks after release from the standby mode.
4. Oscillation is stopped.

When this mode is not used, connect pin SB to VSS.

### **Multichip Operation**

When an LCD is driven with two or more chips, the driving timing of the LCD must be synchronized. In this case, the chips are synchronized with each other by using SYNC input. If SYNC input is high, the LCD driver timing circuit is reset. Apply high pulse to the SYNC input after the operating mode is set.

A high pulse to the SYNC input changes the mode setting data. (The OFF/ON bit is set and the READY bit is reset. See 3. Mode Setting Data in “Input Data Formats”.) Transfer the mode setting data into the LSI after every SYNC operation.

If a power on reset signal is applied to the SYNC pin, the LCD can be off-state when the power is turned on.

When SYNC input is not used, connect pin SYNC to VSS.

When SB input is used, after standby mode is released, a high pulse must be applied to the SYNC input, and mode setting data must be set again.

### **Restriction on Usage**

Minimize the noise by inserting a noise by-pass capacitor ( $\geq 1 \mu\text{F}$ ) between VDD and VSS pins. (Insert one as near chip as possible.)

## Liquid Crystal Display Drive Voltage Circuit (HD61602)

### What is LCD Voltage?

HD61602 drives liquid crystal display using four levels of voltages (Figure 19); VDD, V1, V2, and V3 (VDD is the highest and V3 is the lowest). The voltage between VDD and V3 is called VLCD and it is necessary to apply the appropriate VLCD according to the liquid crystal display. V3 always needs to be supplied regardless of the display duty ratio since it supplies the voltage to the LCD drive circuit of HD61602.

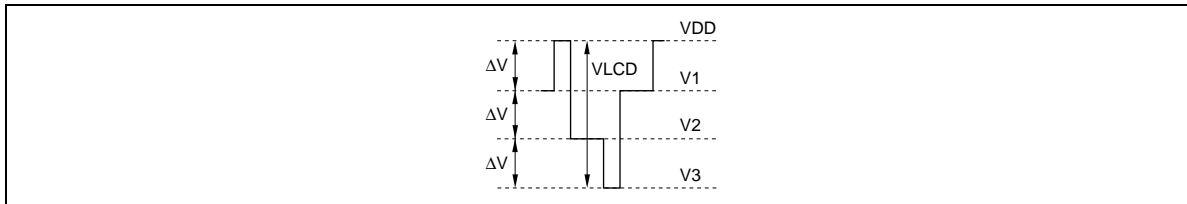

**Figure 19 LCD Output Waveform and Output Levels**

## When Internal Drive Power Supply Is Used

When the internal drive power supply is used, attach C1–C4 for charge pump circuits and variable resistance R1 for deciding display drive voltage to HD61602 as shown in Figure 20.

Internal voltage is available by setting external voltage switching bits of mode setting data 0.

Figure 21 shows voltage characteristics between VDD and VREF1. Voltage is divided at R1, and then input into VREF2. Voltage between VDD and VREF2 is equivalent to  $\Delta V$  in Figure 21, and so VLCD can be changed by regulating the voltage.

VREF2 is usually regulated by variable resistance, but when replacing R1 with two nonvariable resistances take VREF1 between max and min into consideration as shown in Figure 21.

Internal drive power supply is generated by using capacitance, and so large current cannot flow. When large liquid crystal display panel is used, examine the external drive power supply.

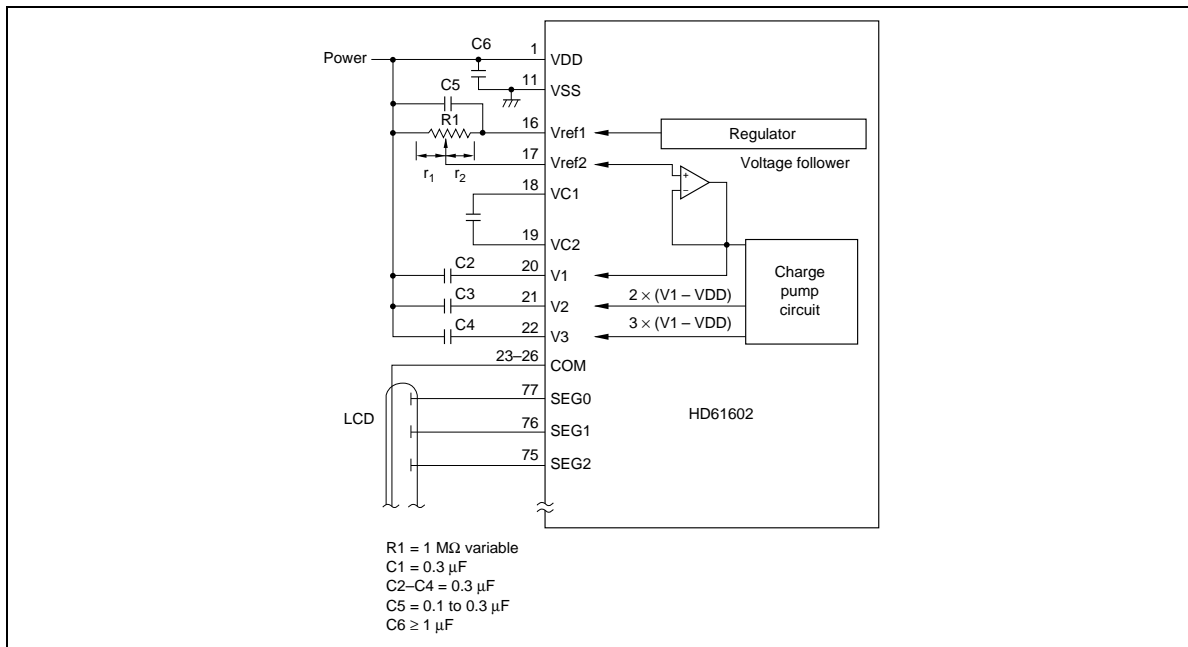

Figure 20 Example

### When External Drive Power Supply Is Used

An external power supply can be used by setting external voltage switching bits of mode setting data to 1. When a large liquid crystal display panel is used, in multichip designs, which need accurate liquid crystal drive voltage, use the external power supply. See Figure 22.

R2–R5 is connected in series between VDD and VSS, and by these resistance ratio each voltage of  $\Delta EV$  and VLCD is generated and then supplied to V1, V2, and V3. C2–C4 are smoothing capacitors.

When regulating brightness, change the resistance value by setting R5 variable resistance.

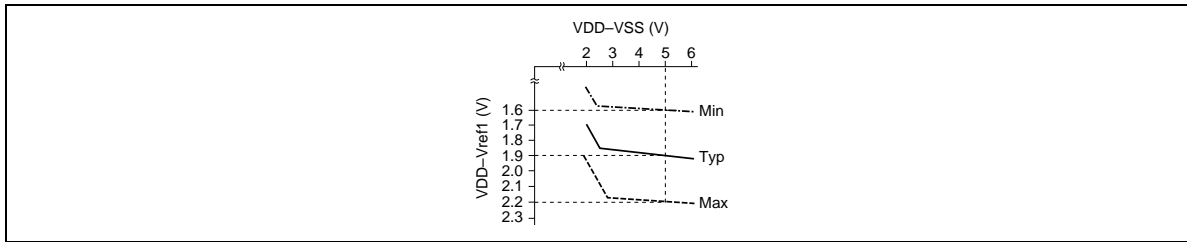

Figure 21 Voltage Characteristics between VDD and Vref1

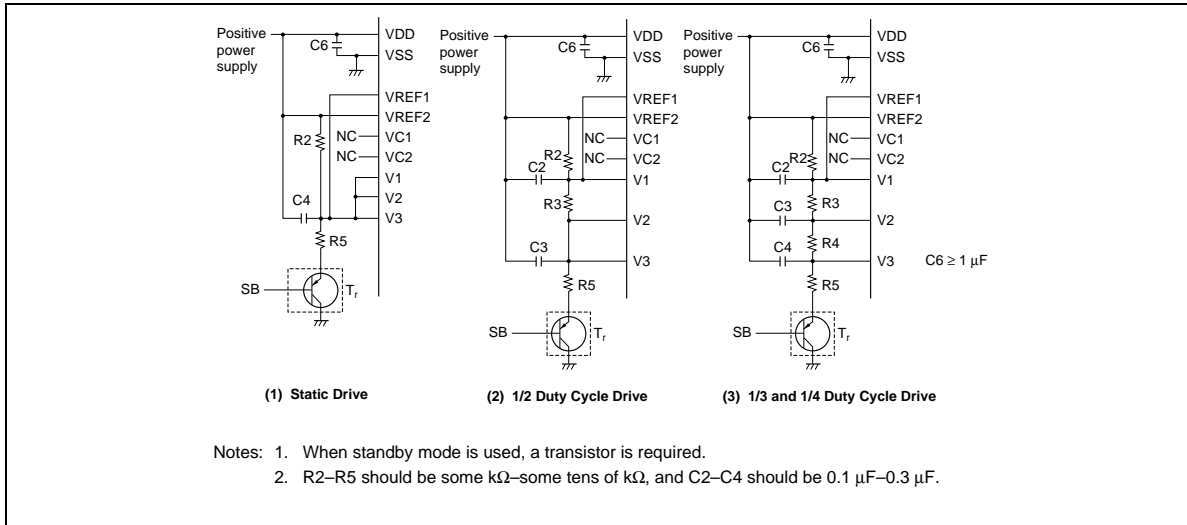

Figure 22 Example when External Drive Voltage Is Used

---

## HD61602/HD61603

---

### Liquid Crystal Display Drive Voltage (HD61603)

As shown in Figure 23, apply LCD drive voltage from the external power supply.

### Oscillation Circuit

#### When Internal Oscillation Circuit Is Used

When the internal oscillation circuit is used, attach an external resistor  $R_{osc}$  as shown in Figure 24. (Insert  $R_{osc}$  as near chip as possible, and make the OSC1 side shorter.)

#### When External Clock Is Used

When an external clock of 100 kHz with CMOS level is provided, pin OSC1 can be used for the input pin. In this case, open pin OSC2.

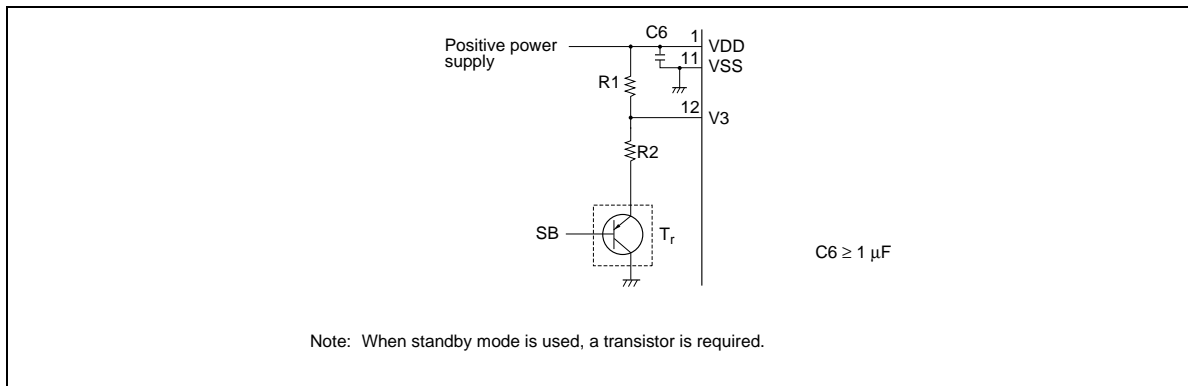

Figure 23 Example of Drive Voltage Generator

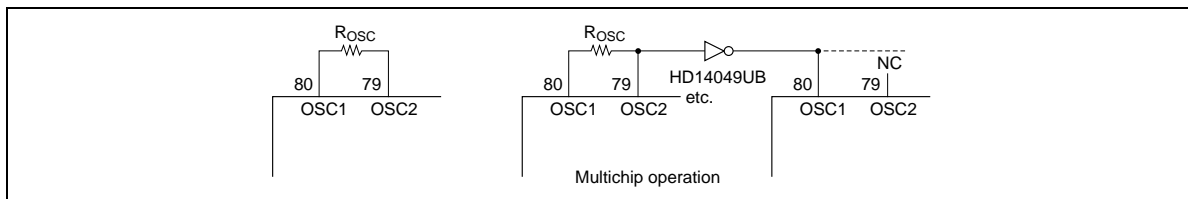

Figure 24 Example of Oscillation Circuit

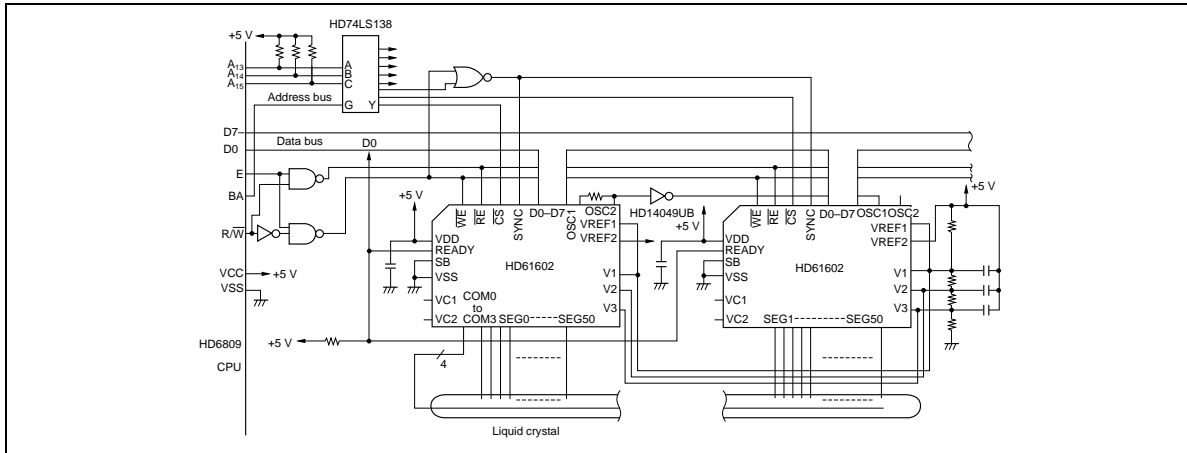

Figure 25 Example (1)

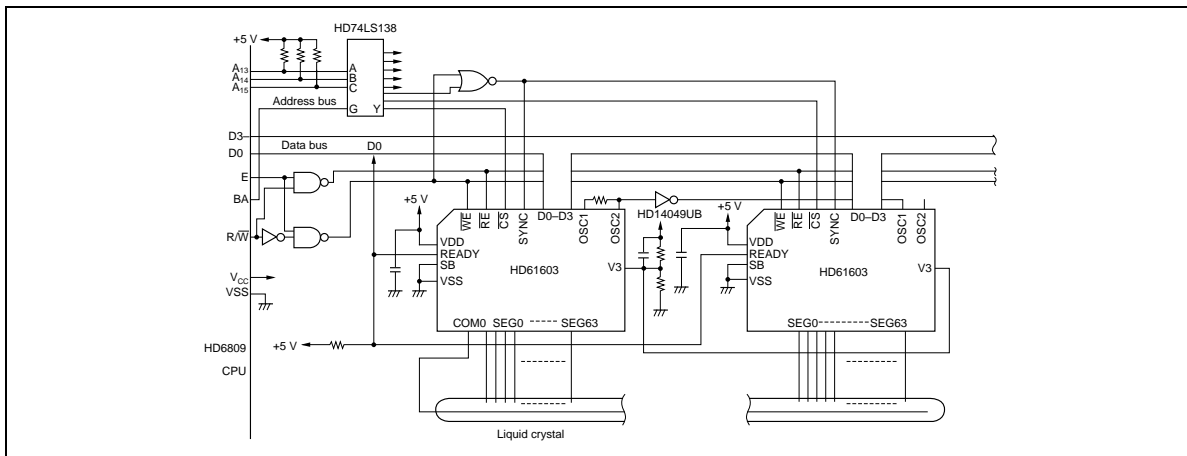

Figure 26 Example (2)

---

## HD61602/HD61603

---

### Absolute Maximum Ratings

Item	Symbol	Limit	Unit
Power supply voltage*	VDD, V1, V2, V3	-0.3 to +7.0	V
Terminal voltage*	VT	-0.3 to VDD +0.3	V
Operating temperature	T <sub>opr</sub>	-20 to +75	°C
Storage temperature	T <sub>stg</sub>	-55 to +125	°C

\* Value referenced to VSS = 0V.

Note: If LSIs are used above absolute maximum ratings, they may be permanently destroyed. Using them within electrical characteristics limits is strongly recommended for normal operation. Use beyond these conditions will cause malfunction and poor reliability.

### Recommended Operating Conditions

Item	Symbol	Limit			Unit
		Min	Typ	Max	
Power supply voltage	VDD	2.2	—	5.5	V
	V1, V2, V3	0	—	VDD	V
Terminal voltage*	VT	0	—	VDD	V
Operating temperature	T <sub>opr</sub>	-20	—	75	°C

\* Value referenced to VSS = 0V.

**Electrical Characteristics**

**DC Characteristics (1) (VSS = 0V, VDD = 4.5 to 5.5V, Ta = -20 to +75°C, unless otherwise noted)**

Item	Symbol	Limit			Unit	Test Condition
		Min	Typ	Max		
Input high voltage	OSC1	VIH1	0.8 VDD	—	VDD	V
	Others	VIH2	2.0	—	VDD	V
Input low voltage	OSC1	VIL1	0	—	0.2 VDD	V
	Others	VIL2	0	—	0.8	V
Output leakage current	READY	I <sub>OH</sub>	—	—	5	μA V <sub>O</sub> = VDD
Output low voltage	READY	VOL	—	—	0.4	V I <sub>OL</sub> = 0.4 mA
Input leakage current* <sup>1</sup>	Input terminal	I <sub>IL1</sub>	-1.0	—	1.0	μA VIN = 0-VDD
	V1	I <sub>IL2</sub>	-20	—	20	μA VIN = VDD-V3
	V2, V3	I <sub>IL3</sub>	-5.0	—	5.0	μA
LCD driver voltage drop	COM0-COM3	Vd1	—	—	0.3	V ±Id = 3 μA for each COM, V3 = VDD-3V
	SEG0-SEG50	Vd2	—	—	0.6	V ±Id = 3 μA for each SEG, V3 = VDD-3V
Power supply current		I <sub>DD</sub>	—	—	100	μA During display* <sup>2</sup> R <sub>OSC</sub> = 360 kΩ
		I <sub>DD</sub>	—	—	5	μA At standby
Internal driving voltage drop	V1, V2, V3	VTR	—	—	0.4	V VREF2 = VDD-1 V, C1-C4 = 0.3 μF, RL = 3 MΩ

Notes: 1. V1, V2: apply only to HD61602.

2. Except the transfer operation of display data and bit data.



## HD61602/HD61603

DC Characteristics (2) (VSS = 0V, VDD = 2.2 to 3.8V, Ta = -20 to +75°C, unless otherwise noted)

Item	Symbol	Limit			Unit	Test Condition	
		Min	Typ	Max			
Input high voltage	V <sub>IH</sub>	0.8 VDD	—	VDD	V		
Input low voltage	V <sub>IL</sub>	0	—	0.1 VDD	V		
Output leakage current	READY	I <sub>OH</sub>	—	—	5	μA	V <sub>IN</sub> = VDD
Output low voltage	READY	V <sub>OL</sub>	—	—	0.1 VDD	V	I <sub>OL</sub> = 0.04 mA
Input leakage current* <sup>1</sup>	Input terminal	I <sub>IL1</sub>	-1.0	0	1.0	μA	V <sub>IN</sub> = 0-VDD
	V1	I <sub>IL2</sub>	-20	—	20	μA	V <sub>IN</sub> = VDD-V3
	V2, V3	I <sub>IL3</sub>	-5.0	—	5.0	μA	
LCD driver voltage drop	COM0-COM3	V <sub>d1</sub>	—	—	0.3	V	±I <sub>d</sub> = 3 μA for each COM, V3 = VDD-3V
	SEG0-SEG50	V <sub>d2</sub>	—	—	0.6	V	±I <sub>d</sub> = 3 μA for each SEG, V3 = VDD-3V
Power supply current		I <sub>SS</sub>	—	—	50	μA	During display* <sup>2</sup> R <sub>OSC</sub> = 330 kΩ
		I <sub>SS</sub>	—	—	5	μA	At standby
Internal driving voltage drop	V1, V2, V3	V <sub>TR</sub>	—	—	0.4	V	VREF2 = VDD-1V, C1-C4 = 0.3 μF, RL = 3 MΩ, VDD = 3-3.8 V

Notes: 1. V1, V2: apply only to HD61602.

2. Except the transfer operation of display data and bit data.

## HD61602/HD61603

**AC Characteristics (1) (VSS = 0V, VDD = 4.5 to 5.5V, Ta = -20 to +75°C, unless otherwise noted)**

Item	Symbol	Limit			Unit	Test Condition	
		Min	Typ	Max			
Oscillation frequency	OSC2	$f_{osc}$	70	100	130	kHz	$R_{osc} = 360\text{ k}\Omega$
External clock frequency	OSC1	$f_{osc}$	70	100	130	kHz	
External clock duty	OSC1	Duty	40	50	60	%	
I/O signal timing		$t_S$	400	—	—	ns	
		$t_H$	10	—	—	ns	
		$t_{WH}$	300	—	—	ns	
		$t_{WL}$	400	—	—	ns	
		$t_{WR}$	400	—	—	ns	
		$t_{DL}$	—	—	1.0	$\mu\text{s}$	Figure 31
		$t_{EN}$	400	—	—	ns	
		$t_{OP1}$	9.5	—	10.5	Clock	For display data transfer
		$t_{OP2}$	2.5	—	3.5	Clock	For bit and mode data transfer
Input signal rise time and fall time		$t_r, t_f$	—	—	25	ns	

## HD61602/HD61603

AC Characteristics (2) (VSS = 0V, VDD = 2.2 to 3.8V, Ta = -20 to +75°C, unless otherwise noted)

Item	Symbol	Limit			Unit	Test Condition	
		Min	Typ	Max			
Oscillation frequency	OSC2	$f_{osc}$	70	100	130	kHz	$R_{osc} = 330\text{ k}\Omega$
External clock frequency	OSC1	$f_{osc}$	70	100	130	kHz	
External clock duty	OSC1	Duty	40	50	60	%	
I/O signal timing (VDD = 3.0–3.8 V)	$t_s$	1.5	—	—		$\mu\text{s}$	
	$t_H$	1.0	—	—		$\mu\text{s}$	
	$t_{WH}$	1.5	—	—		$\mu\text{s}$	
	$t_{WL}$	1.5	—	—		$\mu\text{s}$	
	$t_{DL}$	—	—	2.0		$\mu\text{s}$	Figure 32
	$t_{WR}$	1.5	—	—		$\mu\text{s}$	
	$t_{EN}$	2.0	—	—		$\mu\text{s}$	
	$t_{OP1}$	9.5	—	10.5		Clock	For display data transfer
$t_{OP2}$	2.5	—	3.5		Clock	For bit and mode data transfer	
Input signal rise time and fall time	$t_r, t_f$	—	—	25		ns	

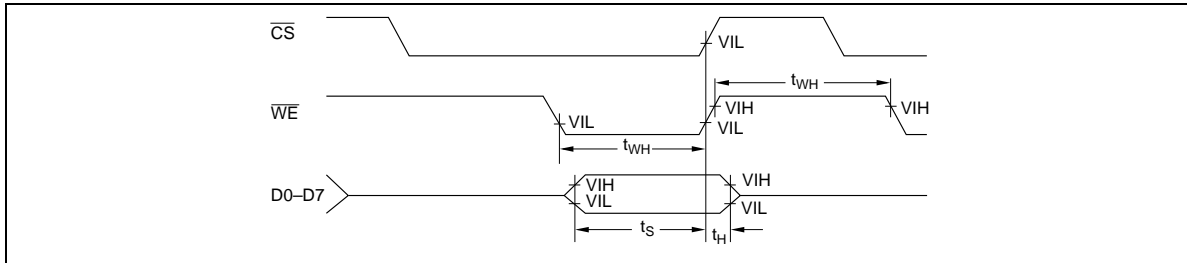

Figure 27 Write Timing ( $\overline{RE}$  Is Fixed at High Level, and SYNC at Low Level)

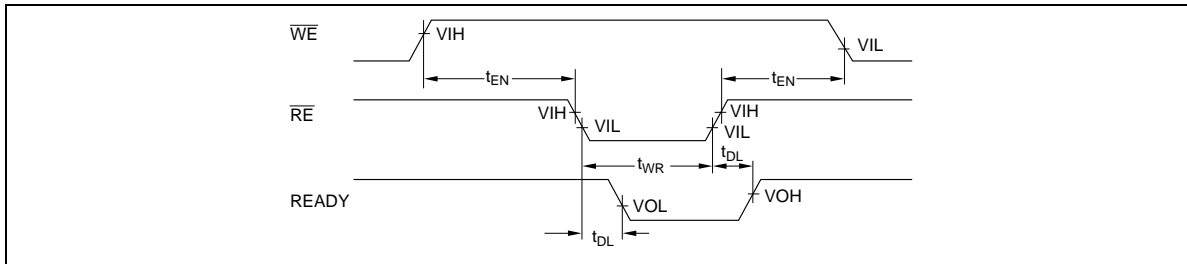
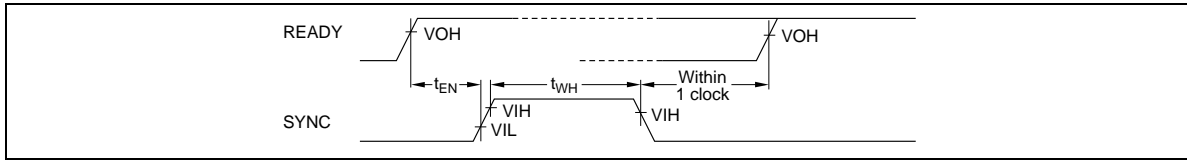

Figure 28 Reset/Read Timing ( $\overline{CS}$  and SYNC Are Fixed at Low Level)



Figure 29  $\overline{READY}$  Timing (When the  $\overline{READY}$  Output Is Always Available)



**Figure 30 SYNC Timing**

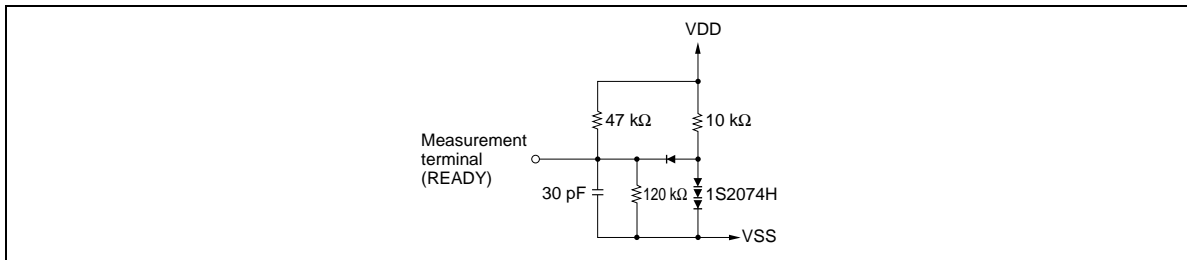

**Figure 31 Bus Timing Load Circuit (LS-TTL Load)**

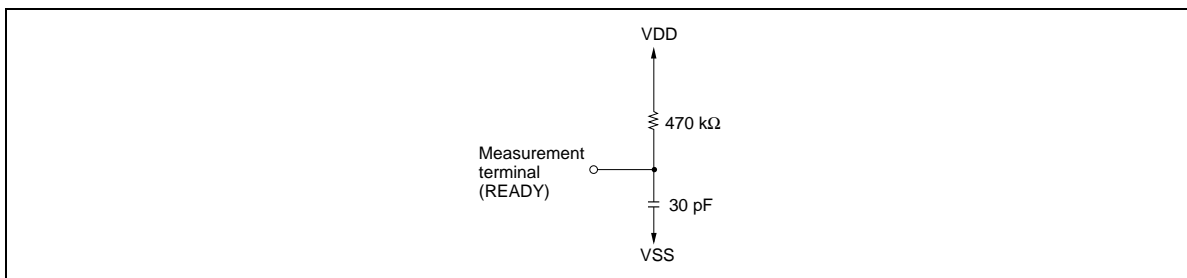

**Figure 32 Bus Timing Load Circuit (CMOS Load)**