

## MSM6577-xx

Operatable at 0.9V and Built-in LCD Driver 4-Bit Microcontroller

### GENERAL DESCRIPTION

The MSM6577 is a 4-bit microcontroller that is fabricated in OKI's low-voltage CMOS technology, enabling operation at 0.9 V. This device incorporates LCD drivers, 8-bit synchronous serial ports, and a buzzer output circuit. The MSM6577 is optimized for remote-control microcontroller applications that are portable and battery powered.

### FEATURES

- Operating range
  - Operating frequency : 32.768 kHz
  - Operating voltage
    - 1.5 V operation : MSM6577K/N/S/U
    - 3.0 V operation : MSM6577L/C/D/E
    - (See Mask Option List.)
  - Operating temperature : -20 to +70°C
- Memory space
  - ROM : 1536 words × 17 bits
  - RAM : 128 words × 4 bits
- Minimum instruction execution time : 61 μs
- I/O port
  - Input-output port : 1 port × 4 bits
  - Input only port : 1 port × 4 bits
  - Output only port : 1 port × 4 bits
- Serial port : 8-bit clock synchronous type
- LCD drivers : 28
  - Duty and frame frequency are selectable by the mask options.
  - 1/3 duty, 1/3 bias : Up to 75 segments
  - 1/2 duty, 1/3 bias : Up to 52 segments
- Halt release timers : 4
  - Timer frequency is selectable by the mask options.
- External interrupt : 4
- Buzzer output : 1
- Clock : 32.768 kHz crystal oscillator
  - Oscillation starts at 0.9 V.
- Power supply voltage : 1.5 V/3.0 V (selectable by mask option)
  - (See Mask Option List)
- Package options:
  - 56-pin plastic QFP (QFP56-P-910-0.65-K) (Product name : MSM6577□-xxGS-K)
  - 56-pin plastic QFP (QFP56-P-910-0.65-2K) (Product name : MSM6577□-xxGS-2K)
  - Chip

xx indicates the code number.

□ indicates the option code.

**BLOCK DIAGRAM**

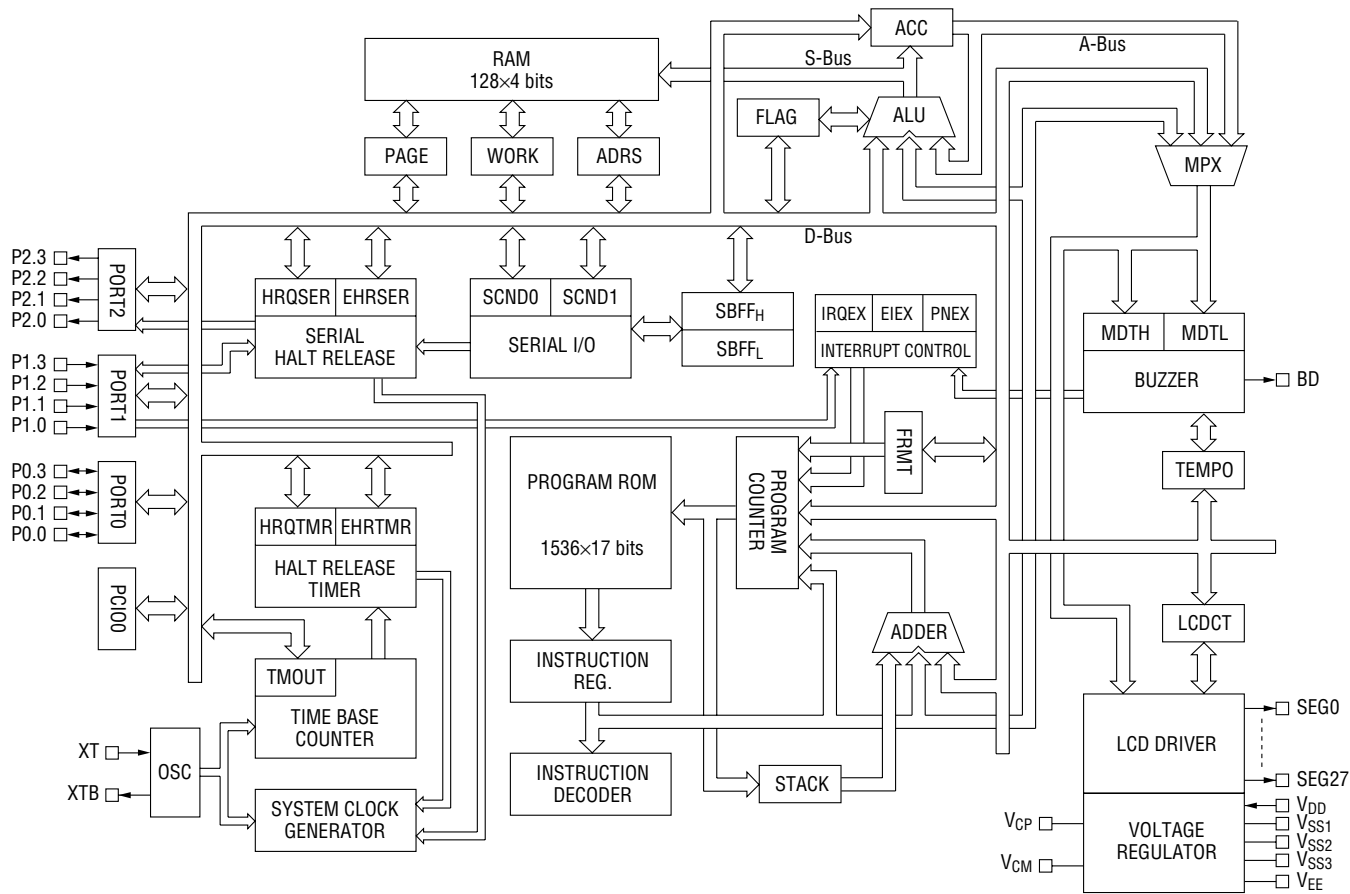

**PIN CONFIGURATION (TOP VIEW)**

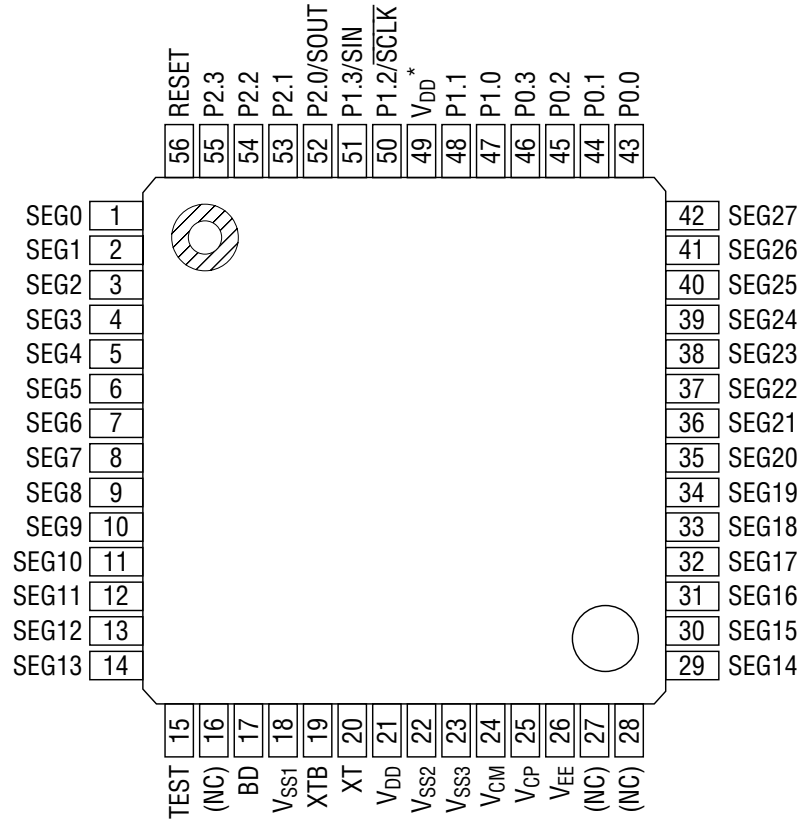

NC: No-connection pin

**56-Pin Plastic QFP**

\* Pin 49 (V<sub>DD</sub>) is provided only when a 56-pin flat package is used.

**PIN DESCRIPTIONS**

Symbol	Type	Description	Circuit			
PORT0 (P0.0 to P0.3)	I/O	<ul style="list-style-type: none"> <li>• 4-bit input-output port</li> <li>• Input or output software selectable.</li> <li>• A pull-up resistor or pull-down resistor can be selected for each bit (P0.0 to P0.3) (via mask option).</li> <li>• When using port as output, the pull-up or pull-down resistor is disconnected from the pin.</li> </ul>	A			
PORT1 (P1.0 to P1.3)	I	<ul style="list-style-type: none"> <li>• 4-bit input port</li> <li>• Pull-up resistor or pull-down resistor can be selected for PORT1 (P1.0 to P1.3) (via mask option).</li> </ul>	P1.0	External Interrupt ports	—	B
			P1.1		—	C
			P1.2		Serial clock pin .... $\overline{\text{SCLK}}$	B
			P1.3		Serial input pin .... SIN	B
PORT2 (P2.0 to P2.3)	O	• 4-bit output port	P2.0		Serial output pin.... SOUT	D
			P2.1 to P2.3		—	E
BD	O	Buzzer output pin				E
RESET	I	<ul style="list-style-type: none"> <li>• Reset input pin</li> <li>• System reset generation level "H" or "L" selectable (mask option)</li> </ul> Note : If "H" is selected, pull-down resistor is used and if "L" is selected, pull-up resistor is used.				F
TEST	I	Test pin (Tie to the negative pole of the battery.)*				G
XT	I	Oscillation crystal connection pin				H
XTB	O					
V <sub>DD</sub>	—	0V power supply pin				—
V <sub>SS1</sub>	—	–1.5 V power supply pin (power supply pin for –1.5 V operation)				—
V <sub>SS2</sub>	—	–3.0 V power supply pin (power supply pin for –3.0 V operation)				—
V <sub>SS3</sub>	—	–4.5 V power supply pin				—
V <sub>CP</sub> V <sub>CM</sub>	—	Capacitor connection pin for voltage converter				—
V <sub>EE</sub>	—	Internal logic power supply pin (voltage regulator output pin)				—
SEG0 to SEG27	O	Liquid crystal display driving pins				I

\* 3.0 V operation ..... V<sub>SS</sub> = V<sub>SS2</sub>  
 1.5 V operation ..... V<sub>SS</sub> = V<sub>SS1</sub>

Pin Circuits

A. Input-output port

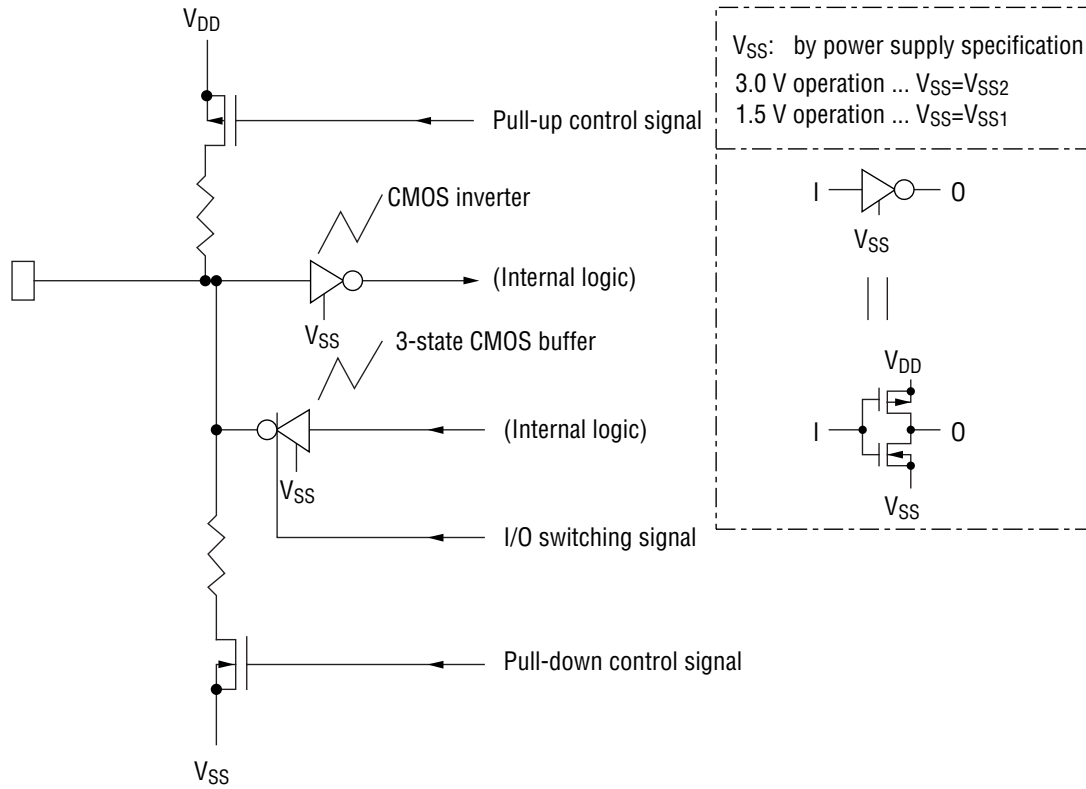

B. Input port

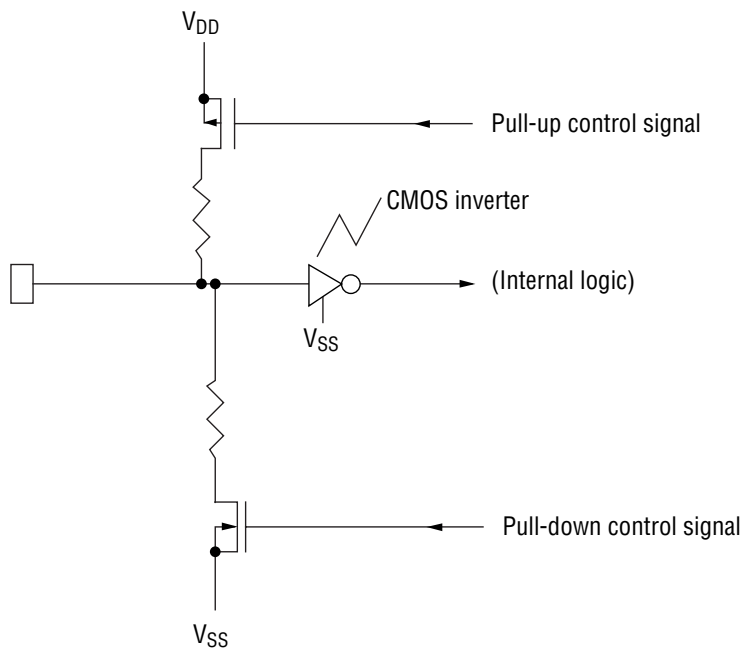

**C. Input port**

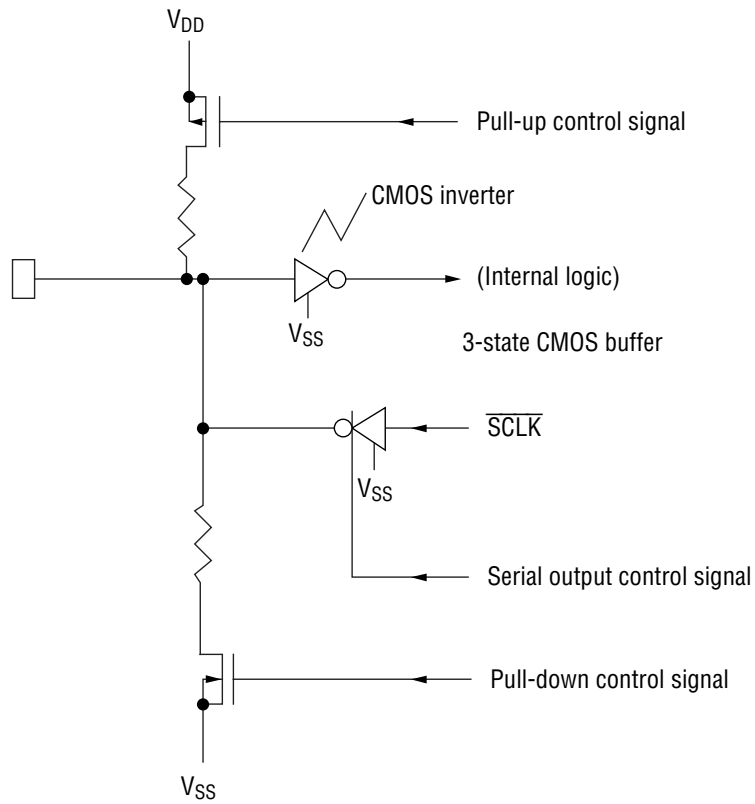

**D. Output port**

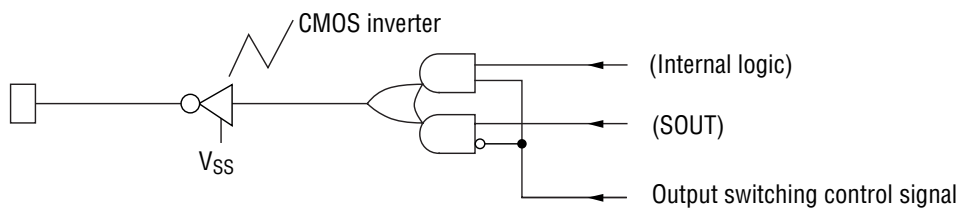

**E. Output port, BD pin**

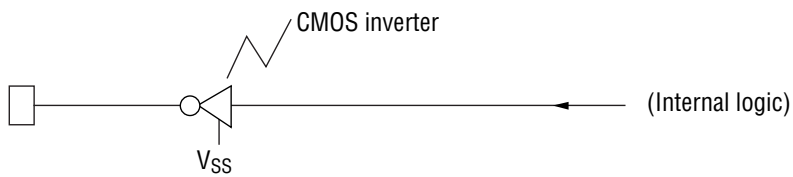

**F. RESET pin**

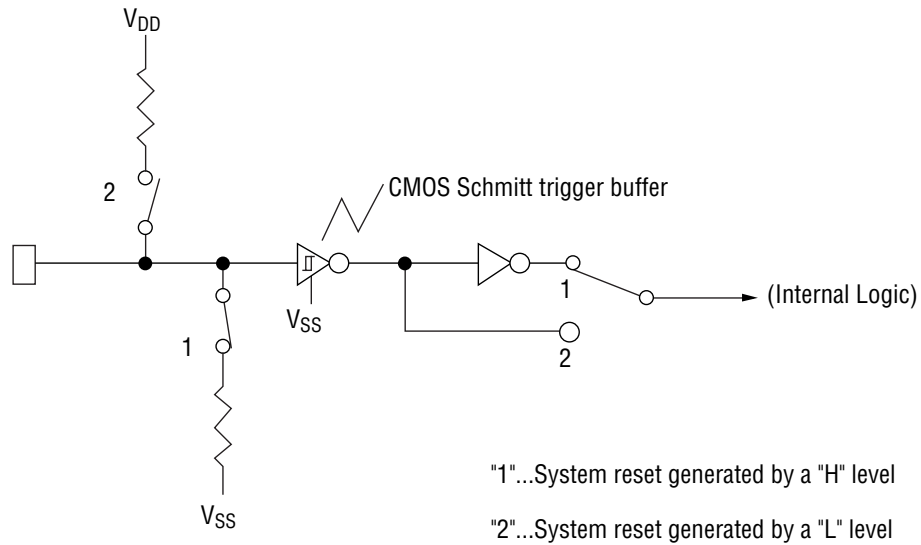

**G. TEST pin**

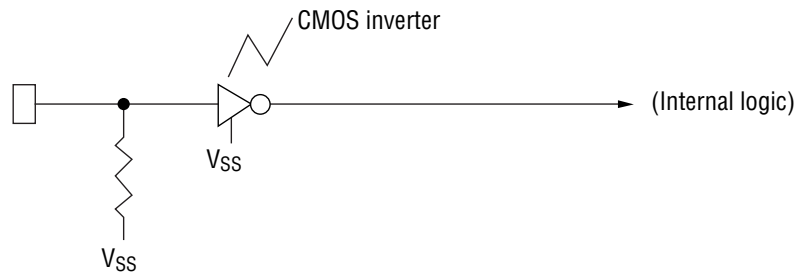

**H. Oscillation part (XT, XTB pins)**

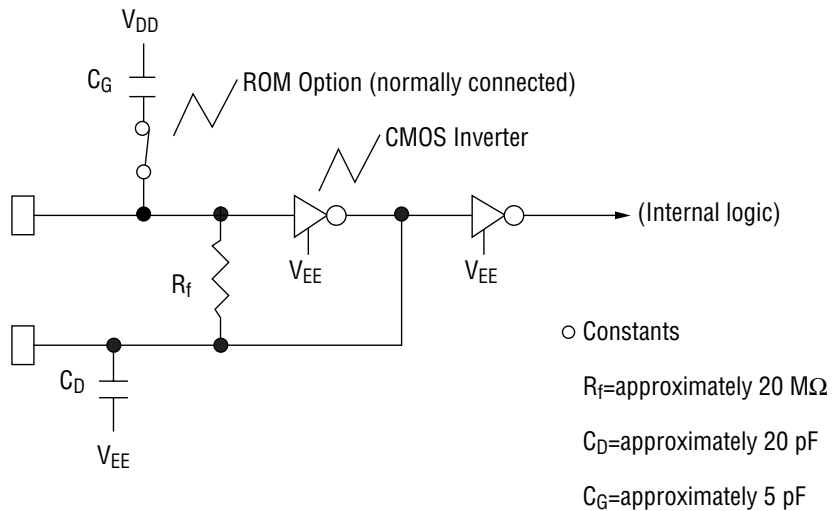

I. LCD driver

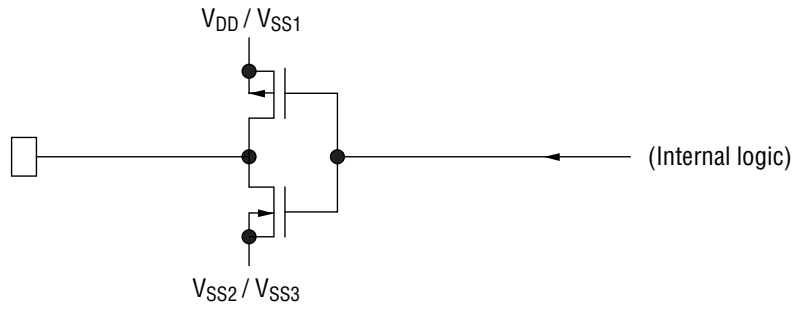



**ABSOLUTE MAXIMUM RATINGS (MSM6577K/77N/77S/77U)**

1.5 V operation •Backup flag (BUF)="0"

The input of the constant voltage circuit corresponds to the output of the voltage converter ( $V_{SS2}$ ).  
 $V_{DD}=0$  V ( $V_{SS1}$ =Battery Voltage)

Parameter	Symbol	Condition	Rating	Unit
Power Supply Voltage 1	$V_{SS1}$	Ta=25°C	-4.0 to +0.3	V
Power Supply Voltage 2	$V_{SS2}$		-7.0 to +0.3	
Power Supply Voltage 3	$V_{SS3}$		-7.0 to +0.3	
Input Voltage	$V_{IN}$		$V_{SS1}-0.3$ to +0.3	
Output Voltage 1 *1,*2	$V_{O1}$		$V_{SS1}-0.3$ to +0.3	
Output Voltage 2 *2	$V_{O2}$		$V_{SS2}-0.3$ to +0.3	
Output Voltage 3 *2	$V_{O3}$		$V_{SS3}-0.3$ to +0.3	
Storage Temperature	$T_{STG}$	—	-55 to +125	°C

\*1 Normal output

\*2 LCD driver output

**RECOMMENDED OPERATING CONDITIONS (MSM6577K/77N/77S/77U)**

1.5 V operation •Backup flag (BUF)="0"

The input of the constant voltage circuit corresponds to the output of the voltage converter ( $V_{SS2}$ ).  
 $V_{DD}=0$  V ( $V_{SS1}$ =Battery Voltage)

Parameter	Symbol	Condition	Range	Unit
Operating Voltage	$V_{op}$	—	-0.9 to -1.75	V
Operating Temperature	$T_{op}$	—	-20 to +70	°C
Oscillation Frequency	$f_{osc}$	—	32.768	kHz

**ELECTRICAL CHARACTERISTICS (MSM6577K/77N/77S/77U)**

1.5 V operation • Backup flag (BUF)="0"

The input of the constant voltage circuit corresponds to the output of the voltage converter ( $V_{SS2}$ ). ( $V_{DD}=0$  V,  $V_{SS1}=-1.5$  V (Battery Voltage),  $V_{SS2}=-3.0$  V,  $V_{SS3}=-4.5$  V,  $f_{OSC}=32.768$  kHz,  $C_X=35$  pF,  $T_a=25^\circ\text{C}$ )

Parameter	Symbol	Condition	Min.	Typ.	Max.	Unit	Applicable Pin
Current Consumption	$I_{DD}$	*1	—	3	—	$\mu\text{A}$	—
Oscillation Start Voltage	$-V_{OSC}$	Within 2 sec	—	—	0.9	V	$V_{SS1}$
Output Current 1	$-I_{OH1}$	$V_O=-0.5$ V	150	—	—	$\mu\text{A}$	PORT0, PORT 2 *2 SOUT, $\overline{\text{SCLK}}$
	$I_{OL1}$	$V_O=-1.0$ V	150	—	—		
Output Current 2	$-I_{OH2}$	$V_O=-0.5$ V	20	—	—	$\mu\text{A}$	BD
	$I_{OL2}$	$V_O=-1.0$ V	20	—	—		
Output Current 3 (LCD driver Common • Segment)	$-I_{OH3}$	$V_{OH}=-0.2$ V	4	—	—	$\mu\text{A}$	SEG0 to SEG27
	$ I_{OMH3} $	$V_{OMH}=V_{SS1}$ $\pm 0.2$ V	4	—	—		
	$ I_{OML3} $	$V_{OML}=V_{SS2}$ $\pm 0.2$ V	4	—	—		
	$I_{OL3}$	$V_{OL}=-4.3$ V	4	—	—		
Input Current 1	$I_{IH1}$	$V_I=0$ V, Input mode, with pull-down resistor	3.75	7.5	15	$\mu\text{A}$	PORT0, PORT1 *2
Input Current 2	$-I_{IL2}$	$V_I=-1.5$ V, Input mode, with pull-up resistor	3.75	7.5	15	$\mu\text{A}$	PORT0, PORT1 *2
Input Leakage Current	$ I_{IL} $	$V_I=0$ V, $-1.5$ V Input mode, without internal resistor	—	—	1	$\mu\text{A}$	PORT0, PORT1 *2 SIN, SOUT, $\overline{\text{SCLK}}$ RESET *3
Input Current 3	$I_{IH3}$	$V_I=0$ V, with pull-down resistor	30	100	200	$\mu\text{A}$	RESET *3 TEST
Input Current 4	$-I_{IL4}$	$V_I=-1.5$ V, with pull-up resistor	30	100	200	$\mu\text{A}$	RESET *3
Input Voltage	$-V_{IH}$	—	—	—	0.3	V	All input pins
	$-V_{IL}$	—	1.2	—	—		

\*1 Dependent on program ("3  $\mu\text{A}$  typ." is under 5% duty of the microcontroller).\*2 PORT0=P0.0 to P0.3, PORT1=P1.0 to P1.3, PORT2=P2.0 to P2.3  
(P1.2 is shared with  $\overline{\text{SCLK}}$ , P1.3 with SOUT, and P2.0 with SIN)

\*3 The RESET pin can be selected by mask option (with pull-down, with pull-up or without internal resistor).

MSM6577K: System reset by a "H" level with a pull-down resistor

MSM6577N: System reset by a "H" level without a pull-down resistor

MSM6577S: System reset by a "L" level with a pull-up resistor

MSM6577U: System reset by a "L" level without a pull-up resistor

**ABSOLUTE MAXIMUM RATINGS (MSM6577K/N/S/U)**

1.5 V operation • Backup flag (BUF)="1"

The input of the constant voltage circuit corresponds to the output of the battery ( $V_{SS1}$ ). $V_{DD}=0\text{ V}$  ( $V_{SS1}$ =Battery Voltage)

Parameter	Symbol	Condition	Rating	Unit
Power Supply Voltage 1	$V_{SS1}$	Ta=25°C	-4.0 to +0.3	V
Power Supply Voltage 2	$V_{SS2}$		-7.0 to +0.3	
Power Supply Voltage 3	$V_{SS3}$		-7.0 to +0.3	
Input Voltage	$V_{IN}$		$V_{SS1}-0.3$ to +0.3	
Output Voltage 1 *1,*2	$V_{O1}$		$V_{SS1}-0.3$ to +0.3	
Output Voltage 2 *2	$V_{O2}$		$V_{SS2}-0.3$ to +0.3	
Output Voltage 3 *2	$V_{O3}$		$V_{SS3}-0.3$ to +0.3	
Storage Temperature	$T_{STG}$	—	-55 to +125	°C

\*1 Normal output

\*2 LCD driver output

**RECOMMENDED OPERATING CONDITIONS (MSM6577K/N/S/U)**

1.5 V operation • Backup flag (BUF)="1"

The input of the constant voltage circuit corresponds to the output of the battery ( $V_{SS1}$ ). $V_{DD}=0\text{ V}$  ( $V_{SS1}$ =Battery Voltage)

Parameter	Symbol	Condition	Range	Unit
Operating Voltage	$V_{op}$	—	-0.9 to -1.75	V
Operating Temperature	$T_{op}$	—	-20 to +70	°C
Oscillation Frequency	$f_{osc}$	—	32.768	kHz

**ELECTRICAL CHARACTERISTICS (MSM6577K/N/S/U)**

1.5 V operation • Backup flag (BUF)="1"

The input of the constant voltage circuit corresponds to the output of the battery ( $V_{SS1}$ ). $(V_{DD}=0\text{ V}, V_{SS1}=-1.5\text{ V (Battery Voltage)}, V_{SS2}=-3.0\text{ V}, V_{SS3}=-4.5\text{ V}, f_{OSC}=32.768\text{ kHz}, C_X=35\text{ pF}, T_a=25^\circ\text{C})$ 

Parameter	Symbol	Condition	Min.	Typ.	Max.	Unit	Applicable Pin
Current Consumption	$I_{DD}$	*1	—	1.5	—	$\mu\text{A}$	—
Oscillation Start Voltage	$-V_{OSC}$	Within 2 sec	—	—	0.9	V	$V_{SS1}$
Output Current 1	$-I_{OH1}$	$V_O=-0.5\text{ V}$	150	—	—	$\mu\text{A}$	PORT0, PORT2 *2 SOUT, SCLK
	$I_{OL1}$	$V_O=-1.0\text{ V}$	150	—	—		
Output Current 2	$-I_{OH2}$	$V_O=-0.5\text{ V}$	20	—	—	$\mu\text{A}$	BD
	$I_{OL2}$	$V_O=-1.0\text{ V}$	20	—	—		
Output Current 3 (LCD driver Common • Segment)	$-I_{OH3}$	$V_{OH}=-0.2\text{ V}$	4	—	—	$\mu\text{A}$	SEG0 to SEG27
	$ I_{OMH3} $	$V_{OMH}=V_{SS1}$ $\pm 0.2\text{ V}$	4	—	—		
	$ I_{OML3} $	$V_{OML}=V_{SS2}$ $\pm 0.2\text{ V}$	4	—	—		
	$I_{OL3}$	$V_{OL}=-4.3\text{ V}$	4	—	—		
Input Current 1	$I_{IH1}$	$V_I=0\text{ V}$ , Input mode, with pull-down resistor	3.75	7.5	15	$\mu\text{A}$	PORT0, PORT1 *2
Input Current 2	$-I_{IL2}$	$V_I=-1.5\text{ V}$ , Input mode, with pull-up resistor	3.75	7.5	15	$\mu\text{A}$	PORT0, PORT1 *2
Input Leakage Current	$ I_{IL} $	$V_I=0\text{ V}, -1.5\text{ V}$ Input mode, without internal resistor	—	—	1	$\mu\text{A}$	PORT0, PORT1 *2 SIN, SOUT, SCLK RESET *3
Input Current 3	$I_{IH3}$	$V_I=0\text{ V}$ , with pull-down resistor	30	100	200	$\mu\text{A}$	RESET *3 TEST
Input Current 4	$-I_{IL4}$	$V_I=-1.5\text{ V}$ , with pull-up resistor	30	100	200	$\mu\text{A}$	RESET *3
Input Voltage	$-V_{IH}$	—	—	—	0.3	V	All input pins
	$-V_{IL}$	—	1.2	—	—		

\*1 Dependent on program ("1.5  $\mu\text{A}$  typ." is under 5% duty of the microcontroller)\*2 PORT0=P0.0 to P0.3, PORT1=P1.0 to P1.3, PORT2=P2.0 to P2.3  
(P1.2 is shared with SCLK, P1.3 with SOUT, and P2.0 with SIN.)

\*3 RESET pin can be selected by mask option (with pull-down, with pull-up or without internal resistor).

MSM6577K: System reset by a "H" level with a pull-down resistor

MSM6577N: System reset by a "H" level without a pull-down resistor

MSM6577S: System reset by a "L" level with a pull-up resistor

MSM6577U: System reset by a "L" level without a pull-up resistor

**ABSOLUTE MAXIMUM RATINGS (MSM6577L/C/D/E)**

3.0 V operation • Backup flag (BUF)="0"

The input of the constant voltage circuit corresponds to the output of the voltage converter (V<sub>SS1</sub>).  
V<sub>DD</sub>=0 V (V<sub>SS2</sub>=Battery Voltage)

Parameter	Symbol	Condition	Rating	Unit
Power Supply Voltage 1	V <sub>SS1</sub>	Ta=25°C	-4.0 to +0.3	V
Power Supply Voltage 2	V <sub>SS2</sub>		-7.0 to +0.3	
Power Supply Voltage 3	V <sub>SS3</sub>		-7.0 to +0.3	
Input Voltage	V <sub>IN</sub>		V <sub>SS2</sub> -0.3 to +0.3	
Output Voltage 1 *2	V <sub>O1</sub>		V <sub>SS1</sub> -0.3 to +0.3	
Output Voltage 2 *1,*2	V <sub>O2</sub>		V <sub>SS2</sub> -0.3 to +0.3	
Output Voltage 3 *2	V <sub>O3</sub>		V <sub>SS3</sub> -0.3 to +0.3	
Storage Temperature	T <sub>STG</sub>	—	-55 to +125	°C

\*1 Normal output

\*2 LCD driver output

**RECOMMENDED OPERATING CONDITIONS (MSM6577L/C/D/E)**

3.0 V operation • Backup flag (BUF)="0"

The input of the constant voltage circuit corresponds to the output of the voltage converter (V<sub>SS1</sub>).  
V<sub>DD</sub>=0 V (V<sub>SS2</sub>=Battery Voltage)

Parameter	Symbol	Condition	Range	Unit
Operating Voltage	V <sub>op</sub>	—	-1.8 to -3.5	V
Operating Temperature	T <sub>op</sub>	—	-20 to +70	°C
Oscillation Frequency	f <sub>OSC</sub>	—	32.768	kHz

**ELECTRICAL CHARACTERISTICS (MSM6577L/C/D/E)**

3.0 V operation • Backup flag (BUF)="0"

The input of the constant voltage circuit corresponds to the output of the voltage converter ( $V_{SS1}$ ). ( $V_{DD}=0$  V,  $V_{SS1}=-1.5$  V,  $V_{SS2}=-3.0$  V (Battery Voltage),  $V_{SS3}=-4.5$  V,  $f_{OSC}=32.768$  kHz,  $C_X=35$  pF,  $T_a=25^\circ\text{C}$ )

Parameter	Symbol	Conditions	Min.	Typ.	Max.	Unit	Applicable Pin
Current Consumption	$I_{DD}$	*1	—	0.75	—	$\mu\text{A}$	—
Oscillation Start Voltage	$-V_{OSC}$	Within 2 sec	—	—	1.8	V	$V_{SS2}$
Output Current 1	$-I_{OH1}$	$V_O=-0.5$ V	500	—	—	$\mu\text{A}$	PORT0, PORT2 *2 SOUT, $\overline{\text{SCLK}}$
	$I_{OL1}$	$V_O=-2.5$ V	500	—	—		
Output Current 2	$-I_{OH2}$	$V_O=-0.5$ V	20	—	—	$\mu\text{A}$	BD
	$I_{OL2}$	$V_O=-2.5$ V	20	—	—		
Output Current 3 (LCD driver Common/Segment)	$-I_{OH3}$	$V_{OH}=-0.2$ V	4	—	—	$\mu\text{A}$	SEG0 to SEG27
	$ I_{OMH3} $	$V_{OMH}=V_{SS1}$ $\pm 0.2$ V	4	—	—		
	$ I_{OML3} $	$V_{OML}=V_{SS2}$ $\pm 0.2$ V	4	—	—		
	$I_{OL3}$	$V_{OL}=-4.3$ V	4	—	—		
Input Current 1	$I_{IH1}$	$V_I=0$ V, Input mode, with pull-down resistor	60	120	240	$\mu\text{A}$	PORT0, PORT1 *2
Input Current 2	$-I_{IL2}$	$V_I=-3.0$ V, Input mode, with pull-up resistor	60	120	240	$\mu\text{A}$	PORT0, PORT1 *2
Input Leakage Current	$ I_{IL} $	$V_I=0$ V, $-3.0$ V Input mode, without internal resistor	—	—	1	$\mu\text{A}$	PORT0, PORT1 *2 SIN, SOUT, $\overline{\text{SCLK}}$ RESET *3
Input Current 3	$I_{IH3}$	$V_I=0$ V, with pull-down resistor	200	750	1500	$\mu\text{A}$	RESET *3 TEST
Input Current 4	$-I_{IL4}$	$V_I=-3.0$ V, with pull-up resistor	200	750	1500	$\mu\text{A}$	RESET *3
Input Voltage	$-V_{IH}$	—	—	—	0.5	V	All input pins
	$-V_{IL}$	—	2.5	—	—		

\*1 Dependent on program ("0.75  $\mu\text{A}$  typ." is under 5% duty of the MCU.)\*2 PORT0=P0.0 to P0.3, PORT1=P1.0 to P1.3, PORT2=P2.0 to P2.3  
(P1.2 is shared with  $\overline{\text{SCLK}}$ , P1.3 with SOUT, and P2.0 with SIN.)

\*3 RESET pin can be selected by mask option (with pull-down, with pull-up or without internal resistor).

MSM6577L: System reset by a "H" level with a pull-down resistor

MSM6577C: System reset by a "H" level without a pull-down resistor

MSM6577D: System reset by a "L" level with a pull-up resistor

MSM6577E: System reset by a "L" level without a pull-up resistor

**ABSOLUTE MAXIMUM RATINGS (MSM6577L/C/D/E)**

3.0 V operation •Backup flag (BUF)="1"

The input of the constant voltage circuit corresponds to the output of the battery ( $V_{SS2}$ ). $V_{DD}=0\text{ V}$  ( $V_{SS2}$ =Battery Voltage)

Parameter	Symbol	Condition	Rating	Unit
Supply Voltage 1	$V_{SS1}$	Ta=25°C	-4.0 to +0.3	V
Supply Voltage 2	$V_{SS2}$		-7.0 to +0.3	
Supply Voltage 3	$V_{SS3}$		-7.0 to +0.3	
Input Voltage	$V_{IN}$		$V_{SS2}-0.3$ to +0.3	
Output Voltage 1 *2	$V_{O1}$		$V_{SS1}-0.3$ to +0.3	
Output Voltage 2 *1,*2	$V_{O2}$		$V_{SS2}-0.3$ to +0.3	
Output Voltage 3 *2	$V_{O3}$		$V_{SS3}-0.3$ to +0.3	
Storage Temperature	$T_{STG}$	—	-55 to +125	°C

\*1 Normal output

\*2 LCD driver output

**RECOMMENDED OPERATING CONDITIONS (MSM6577L/C/D/E)**

3.0 V operation •Backup flag (BUF)="1"

The input of the constant voltage circuit corresponds to the output of the battery ( $V_{SS2}$ ). $V_{DD}=0\text{ V}$  ( $V_{SS2}$ =Battery Voltage)

Parameter	Symbol	Condition	Range	Unit
Operating Voltage	$V_{op}$	—	-0.9 to -3.5	V
Operating Temperature	$T_{op}$	—	-20 to +70	°C
Oscillation Frequency	$f_{OSC}$	—	32.768	kHz

**ELECTRICAL CHARACTERISTICS (MSM6577L/C/D/E)**

3.0 V operation • Backup flag (BUF)="1"

The input of the constant voltage circuit corresponds to the output of the battery ( $V_{SS2}$ ). $(V_{DD}=0\text{ V}, V_{SS1}=-1.5\text{ V}, V_{SS2}=-3.0\text{ V (Battery Voltage)}, V_{SS3}=-4.5\text{ V}, f_{OSC}=32.768\text{ kHz}, C_X=35\text{ pF}, T_a=25^\circ\text{C})$ 

Parameter	Symbol	Condition	Min.	Typ.	Max.	Unit	Applicable Pin
Current Consumption	$I_{DD}$	*1	—	1.5	—	$\mu\text{A}$	—
Oscillation Start Voltage	$-V_{OSC}$	Within 2 sec	—	—	0.9	V	$V_{SS2}$
Output Current 1	$-I_{OH1}$	$V_O=-0.5\text{ V}$	500	—	—	$\mu\text{A}$	PORT0, PORT2 *2 SOUT, $\overline{\text{SCLK}}$
	$I_{OL1}$	$V_O=-2.5\text{ V}$	500	—	—		
Output Current 2	$-I_{OH2}$	$V_O=-0.5\text{ V}$	20	—	—	$\mu\text{A}$	BD
	$I_{OL2}$	$V_O=-2.5\text{ V}$	20	—	—		
Output Current 3 (LCD driver Common • Segment)	$-I_{OH3}$	$V_{OH}=-0.2\text{ V}$	4	—	—	$\mu\text{A}$	SEG0 to SEG27
	$ I_{OMH3} $	$V_{OMH}=V_{SS1}$ $\pm 0.2\text{ V}$	4	—	—		
	$ I_{OML3} $	$V_{OML}=V_{SS2}$ $\pm 0.2\text{ V}$	4	—	—		
	$I_{OL3}$	$V_{OL}=-4.3\text{ V}$	4	—	—		
Input Current 1	$I_{IH1}$	$V_I=0\text{ V}$ , Input mode, with pull-down resistor	60	120	240	$\mu\text{A}$	PORT0, PORT1 *2
Input Current 2	$-I_{IL2}$	$V_I=-3.0\text{ V}$ , Input mode, with pull-up resistor	60	120	240	$\mu\text{A}$	PORT0, PORT1 *2
Input Leakage Current	$ I_{IL} $	$V_I=0\text{ V}, -3.0\text{ V}$ Input mode, without internal resistor	—	—	1	$\mu\text{A}$	PORT0, PORT1 *2 SIN, SOUT, $\overline{\text{SCLK}}$ RESET *3
Input Current 3	$I_{IH3}$	$V_I=0\text{ V}$ , with pull-down resistor	200	750	1500	$\mu\text{A}$	RESET *3 TEST
Input Current 4	$-I_{IL4}$	$V_I=-3.0\text{ V}$ , with pull-up resistor	200	750	1500	$\mu\text{A}$	RESET *3
Input Voltage	$-V_{IH}$	—	—	—	0.5	V	All input pins
	$-V_{IL}$	—	2.5	—	—		

\*1 Dependent on program ("1.5  $\mu\text{A}$  typ." is under 5% duty of the MCU.)\*2 PORT0=P0.0 to P0.3, PORT1=P1.0 to P1.3, PORT2=P2.0 to P2.3  
(P1.2 is shared with  $\overline{\text{SCLK}}$ , P1.3 with SOUT, and P2.0 with SIN.)

\*3 RESET pin can be selected by mask option (with pull-down, with pull-up or without internal resistor).

MSM6577L: System reset by a "H" level with a pull-down resistor

MSM6577C: System reset by a "H" level without a pull-down resistor

MSM6577D: System reset by a "L" level with a pull-up resistor

MSM6577E: System reset by a "L" level without a pull-up resistor



**MASK OPTION LIST**

The device names for the MSM6577-xx are differentiated as follows, depending on the combination of a power supply voltage and RESET pin function.

<b>No.</b>	<b>Battery</b>	<b>RESET Pin Function</b>	<b>Device</b>
1	1.5 V operation	System reset by a "H" level with a pull-down resistor	MSM6577K-xx
2	1.5 V operation	System reset by a "H" level without a pull-down resistor	MSM6577N-xx
3	1.5 V operation	System reset by a "L" level with a pull-up resistor	MSM6577S-xx
4	1.5 V operation	System reset by a "L" level without a pull-up resistor	MSM6577U-xx
5	3.0 V operation	System reset by a "H" level with a pull-down resistor	MSM6577L-xx
6	3.0 V operation	System reset by a "H" level without a pull-down resistor	MSM6577C-xx
7	3.0 V operation	System reset by a "L" level with a pull-up resistor	MSM6577D-xx
8	3.0 V operation	System reset by a "L" level without a pull-up resistor	MSM6577E-xx

**NOTES ON USE**

**Power Supply for 0.9 V Microcontroller Series: Backup Flag and Constant-Voltage Circuit**

The 0.9 V microcontroller series have a built-in constant-voltage circuit. The output of this constant-voltage circuit powers the microcontroller's internal logic circuits. Setting a backup flag (BUF) allows the input of the constant voltage circuit to be switched to either the battery or the output generated in the voltage converter, based on the battery voltage. A battery voltage of 1.5 V or 3.0 V can be selected.

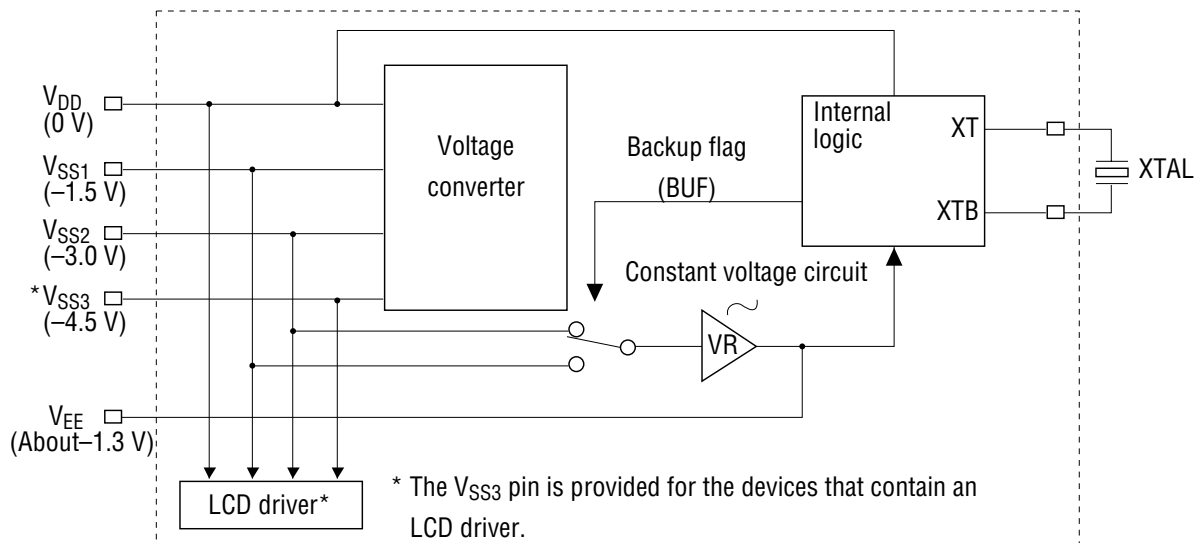

The output ( $V_{EE}$ ) of the constant-voltage circuit is set at approximately -1.3 V. This allows the current consumed by the internal logic to be limited, irrespective of the battery voltage. However, if the input of the constant voltage circuit is below this set value (about -1.3 V), the output ( $V_{EE}$ ) is equal to the input. The 0.9 V microcontroller can be operated even if the internal voltage (output from the constant-voltage circuit) falls to 0.9 V. Setting the backup flag allows a larger operating voltage margin despite changes in internal voltage due to noise. For example, for the 1.5 V operation, setting the backup flag to "0" supplies twice the battery voltage to the constant-voltage circuit. Thus, even if the battery voltage falls to 0.9 V, the output voltage ( $V_{EE}$ ) is maintained at -1.3 V, providing a larger margin of operating voltage of the internal logic circuits because 1.8 V is applied to the input of the constant-voltage circuit. Figures 1 to 4 show the internal status depending on the backup flag settings for the battery, as well as status features.

**(Figure 1) 1.5 V Operation (Backup Flag="1")**

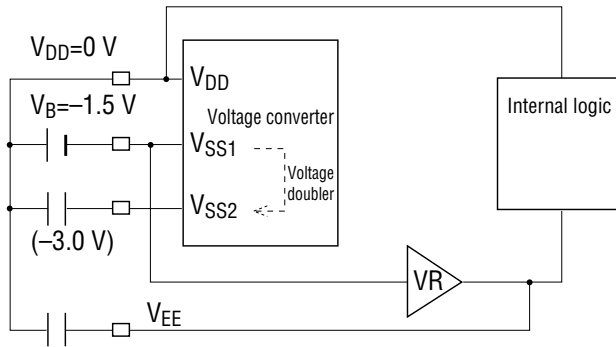

Internal status	The battery level $V_{SS1}$ is applied to the input of the constant voltage circuit.
Operating range	-0.9 to -1.75 V
Current consumption	1.5 $\mu$ A*
Feature	When the battery level is powered down, the internal circuit is powered directly by the battery.

\* When the software duty is about 5%

**(Figure 2) 1.5 V Operation (Backup Flag="0")**

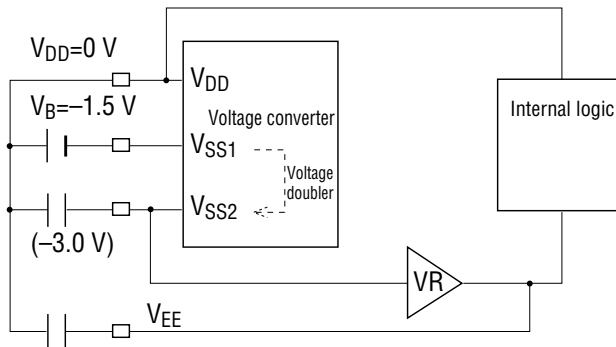

Internal status	A doubled level of $V_{SS2}$ is applied to the input of the constant voltage circuit.
Operating range	-0.9 to -1.75 V
Current consumption	3 $\mu$ A*
Feature	When the battery level is powered down, a larger operating voltage margin is gained, compared to the case of Figure 1.

\* When the software duty is about 5%

**(Figure 3) 3.0 V Operation (Backup Flag="1")**

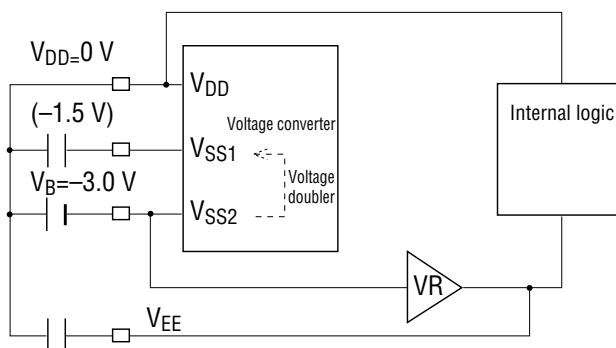

Internal status	The battery level $V_{SS2}$ is applied to the input of the constant voltage circuit.
Operating range	-0.9 to -3.5 V
Current consumption	1.5 $\mu$ A*
Feature	When the battery level is powered down, the internal circuit is powered directly by the battery.

\* When the software duty is about 5%

(Figure 4) 3.0 V Operation (Backup Flag="0")

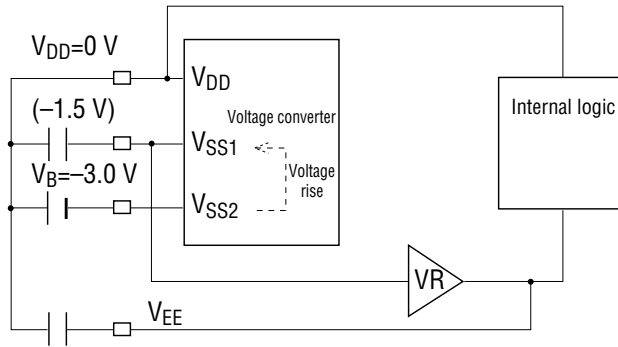

Internal status	A doubled level of $V_{SS1}$ is applied to the input of the constant voltage circuit.
Operating range	-1.8 to -3.5 V
Current consumption	0.75 $\mu A^*$
Feature	When the battery level is powered down, a smaller operating voltage margin is gained, compared to the case of Figure 3.

\* When the software duty is about 5%

PACKAGE DIMENSIONS

(Unit : mm)

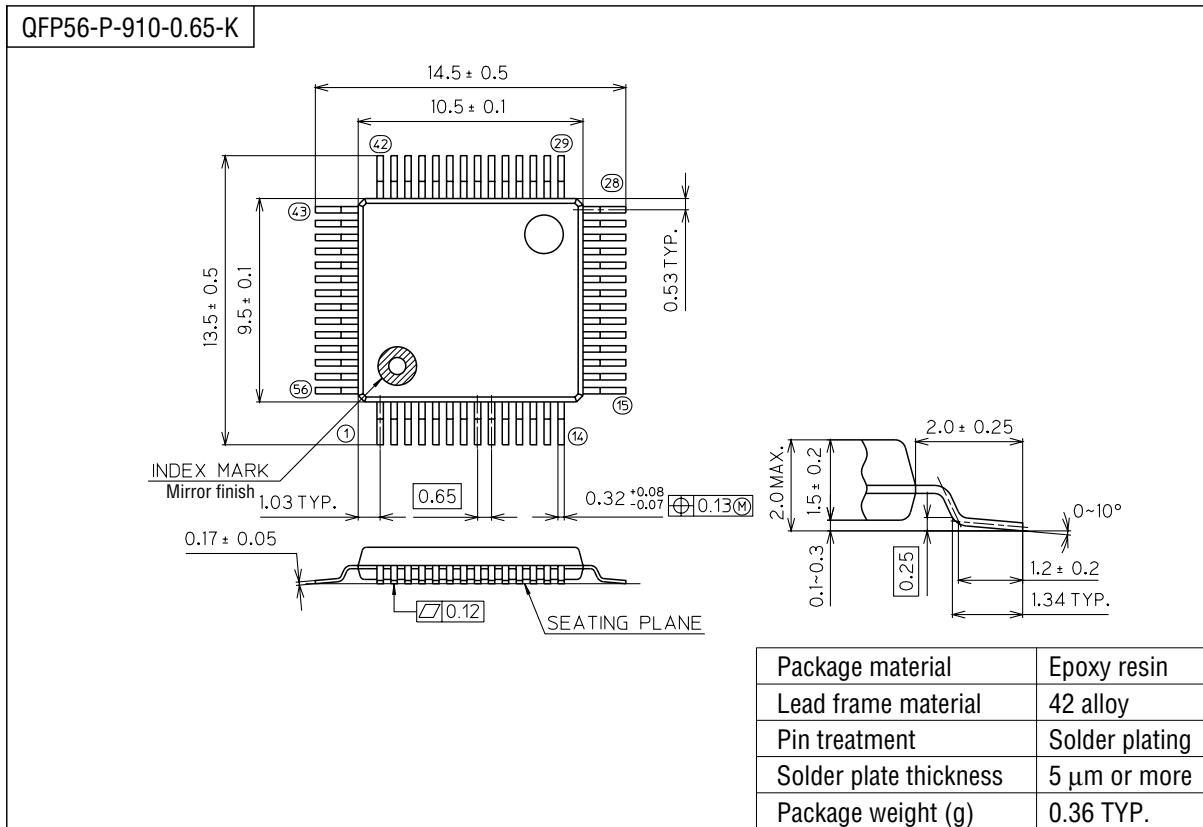

Notes for Mounting the Surface Mount Type Package

The SOP, QFP, TSOP, SOJ, QFJ (PLCC), SHP and BGA are surface mount type packages, which are very susceptible to heat in reflow mounting and humidity absorbed in storage. Therefore, before you perform reflow mounting, contact Oki's responsible sales person for the product name, package name, pin number, package code and desired mounting conditions (reflow method, temperature and times).

(Unit : mm)

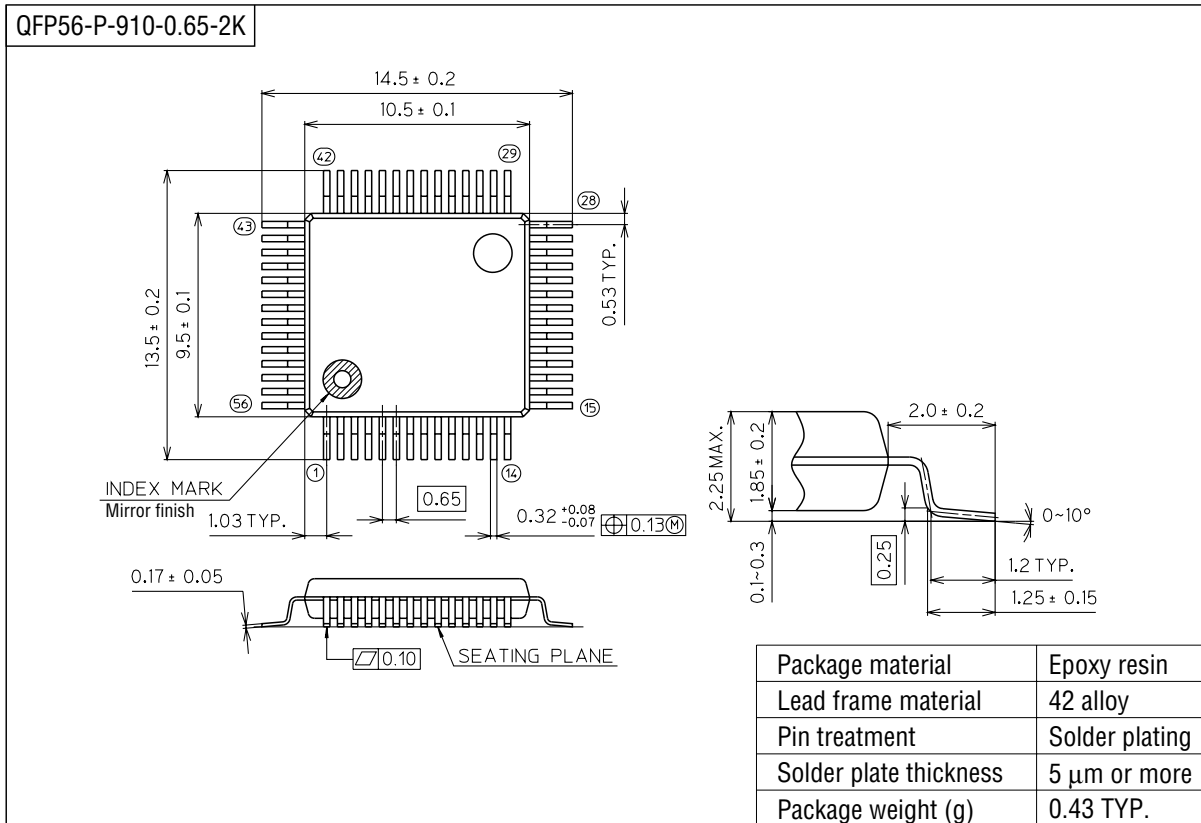

Notes for Mounting the Surface Mount Type Package

The SOP, QFP, TSOP, SOJ, QFJ (PLCC), SHP and BGA are surface mount type packages, which are very susceptible to heat in reflow mounting and humidity absorbed in storage. Therefore, before you perform reflow mounting, contact Oki's responsible sales person for the product name, package name, pin number, package code and desired mounting conditions (reflow method, temperature and times).