

HD66740

(112 x 80-dot Graphics LCD Controller/Driver)

HITACHI

Rev 1.0
August, 2001

Description

The HD66740, 112-by-80 dot-matrix graphics LCD controller and driver LSI, displays graphics such as text, kanji and pictograms. It can be configured to drive a dot-matrix liquid crystal under the control of the microprocessor connected via the clock-synchronized serial or 4/8-bit bus. The HD66740 has a smooth vertical scroll display and a double-height display for the remaining bit map areas. It fixed-displays a part of the graphics icons so that the user can easily see a variety of information.

The HD66740 has various functions to reduce the power consumption of an LCD system such as low-voltage operation of 1.8 V min., a booster to generate maximum five-times LCD drive voltage from the supplied voltage, and voltage-followers to decrease the direct current flow in the LCD drive bleeder-resistors. Combining these hardware functions with software functions such as standby and sleep modes allows fine power control. The HD66740 is suitable for any portable battery-driven product requiring long-term driving capabilities such as cellular phones, pagers, or electronic wallets.

Features

- Control and drive of a graphics LCD
- 112 x 80-dot display
- Fixed display of graphics icons (pictograms)
- Low-power operation support:
 - $V_{CC} = 1.8$ to 3.6 V (low voltage)
 - $V_{LCD} = 4.5$ to 15.0 V (liquid crystal drive voltage)
 - Triple, quadruple, or five-times booster for liquid crystal drive voltage
 - 64-step contrast adjuster and voltage followers to decrease direct current flow in the LCD drive bleeder-resistors
 - Power-save functions such as the standby mode and sleep mode supported
 - Programmable drive duty ratios and bias values displayed on LCD
- High-speed clock-synchronized serial interface (serial transfer rate: 5 MHz max.)
- I2C bus interface
- High-speed 4-/8-bit bus interface capability
- 112-segment \times 80-common liquid crystal display driver
- 1,120-byte (112 \times 80 dots) character generator RAM

HITACHI

HD66740

- Vertical smooth scroll
- Partial smooth scroll control (fixed display of graphics icons)
- Vertical double-height display by each display line
- Black-and-white reversed display
- Wide range of instruction functions:
 - Display on/off control, black-and-white reversed
- No wait time for instruction execution and RAM access
- Internal oscillation and hardware reset
- n-raster-row AC liquid-crystal drive (C-pattern waveform drive)
- Shift change of segment and common driver
- Tape carrier package (TCP)

Table 1 **Programmable Display Sizes and Duty Ratios**

Duty Ratio	Optimum Drive Bias	Graphics Display			
		Bit Map	12 x 13-dot Font Width	14 x 15-dot Font Width	16 x 16-dot Font Width
1/32	1/7	112 x 32 dots	2 lines x 9 characters	2 lines x 8 characters	2 lines x 7 characters
1/40	1/7	112 x 40 dots	3 lines x 9 characters	2.5 lines x 8 characters	2.5 lines x 7 characters
1/48	1/8	112 x 48 dots	3 lines x 9 characters	3 lines x 8 characters	3 line x 7 characters
1/56	1/8	112 x 56 dots	4 lines x 9 characters	3.5 lines x 8 characters	3.5 lines x 7 characters
1/64	1/9	112 x 64 dots	5 lines x 9 characters	4 lines x 8 characters	4 lines x 7 characters
1/72	1/9.5	112 x 72 dots	6 lines x 9 characters	4.5 lines x 8 characters	4.5 lines x 7 characters
1/80	1/10	112 x 80 dots	6 lines x 9 characters	5 lines x 8 characters	5 lines x 7 characters

<Target values>

Total Current Consumption Characteristics (Vcc = 3 V, TYP Conditions, LCD Drive Power Current Included)

Character Display Dot Size	Duty Ratio	R-C Oscillation Frequency	Frame Frequency	Total Power Consumption				
				Internal Logic	LCD Power	Total*	Sleep Mode	Standby Mode
112 x 32 dots	1/32	75 kHz	73 Hz	(27 μA)	(16 μA)	Triple (75 μA)	(15 μA)	0.1 μA
112 x 40 dots	1/40	75 kHz	73 Hz	(27 μA)	(16 μA)	Triple (75 μA)	(15 μA)	
112 x 48 dots	1/48	75 kHz	74 Hz	(27 μA)	(16 μA)	Triple (75 μA)	(15 μA)	
112 x 56 dots	1/56	75 kHz	74 Hz	(27 μA)	(16 μA)	Triple (75 μA)	(15 μA)	
112 x 64 dots	1/64	75 kHz	73 Hz	(27 μA)	(18 μA)	Quadruple (99 μA)	(15 μA)	
112 x 72 dots	1/72	80 kHz	70 Hz	(32 μA)	(18 μA)	Quadruple (104 μA)	(15 μA)	
112 x 80 dots	1/80	90 kHz	70 Hz	(35 μA)	(20 μA)	Five-times (135 μA)	(15 μA)	

Note : When a triple, quadruple, or five-times booster is used:
 the total power consumption = Internal logic current + LCD power current x 3 (triple booster),
 the total power consumption = Internal logic current + LCD power current x 4 (quadruple booster),
 and
 the total power consumption = Internal logic current + LCD power current x 5 (five-times booster)

Type Name

Types	External Dimensions	Bus Interface	Operation Voltages
HD66740TB0	Bending TCP	4/8-bits parallel and clock synchronized serial	1.8 V to 3.6 V
HD66740WTB0	Bending TCP	4/8-bits parallel and I2C bus interface	
HCD66740BP	Au-bumped chip	4/8-bits parallel and clock synchronized serial	
HCD66740WBP	Au-bumped chip	4/8-bits parallel and I2C bus interface	

HD66740

LCD Specification Comparison

Items	HD66725	HD66728	(Under development)
			HD66740
Character display sizes	16 characters x 3 lines	16 characters x 10 lines	—
Graphic display sizes	96 x 26 dots	112 x 80 dots	112 x 80 dots
Multiplexing icons	192	—	—
Annunciator	1/2 duty: 192	—	—
Key scan control	8 x 4	8 x 4	—
LED control ports	—	—	—
General output ports	3	3	—
Operating power voltages	1.8 V to 5.5 V	1.8 V to 5.5 V	1.8 V to 3.6 V
Liquid crystal drive voltages	3 V to 6 V	4.5 V to 15 V	4.5 V to 15 V
I2C bus	—	—	I2C bus interface (HD66740W)
Serial bus	Clock-synchronized serial	Clock-synchronized serial	Clock-synchronized serial
Parallel bus	4 bits, 8 bits	4 bits, 8 bits	4 bits, 8 bits
Expansion driver control	Impossible	Impossible	Impossible
Liquid crystal drive duty ratios	1/2, 10, 18, 26	1/8, 16, 24, 32, 40, 48, 56, 64, 72, 80	1/8, 16, 24, 32, 40, 48, 56, 64, 72, 80
Liquid crystal drive biases	1/4 to 1/6.5	1/4 to 1/10	1/4 to 1/10
Liquid crystal drive waveforms	B	B, C	B, C
Liquid crystal voltage booster	Single, double, or triple	Triple, quadruple, or five-times	Triple, quadruple, or five-times
Bleeder-resistor for liquid crystal drive	Incorporated (external)	Incorporated (external)	Incorporated (external)
Liquid crystal drive operational amplifier	Incorporated	Incorporated	Incorporated
Liquid crystal contrast adjuster	Incorporated	Incorporated	Incorporated
Horizontal smooth scroll	3-dot unit	—	—
Vertical smooth scroll	Line unit	Line unit	Line unit
Double-height display	Yes	Yes	Yes
DDRAM	80 x 8	160 x 8	—
CGROM	20,736	20,736	—
CGRAM	384 x 8	1,120 x 8	1,120 x 8
SEGRAM	96 x 8	—	—
No. of CGROM fonts	240 + 192	240 + 192	—
No. of CGRAM fonts	64	64	—
Font sizes	6 x 8	6 x 8	—
Bit map areas	96 x 26	112 x 80	112 x 80
R-C oscillation resistor/oscillation frequency	External resistor, incorporated (32 kHz)	External resistor (70–90 kHz)	External resistor (70–90 kHz)
Reset function	External	External	External
Low power control	Partial display off Oscillation off Liquid crystal power off Key wake-up interrupt	Partial display off Oscillation off Liquid crystal power off Key wake-up interrupt	Partial display off Oscillation off Liquid crystal power off
SEG/COM direction switching	SEG, COM	SEG, COM	SEG, COM
QFP package	—	—	—
TQFP package	—	—	—
TCP package	TCP-170	TCP-243	TCP-233
Bare chip	—	—	—
Bumped chip	Yes	Yes	Yes
No. of pins	170	243	243
Chip sizes	10.97 x 2.51	13.67 x 2.78	9.40 x 2.18
Pad intervals	80 μm	70 μm	50 μm

HITACHI

HD66740 Block Diagram

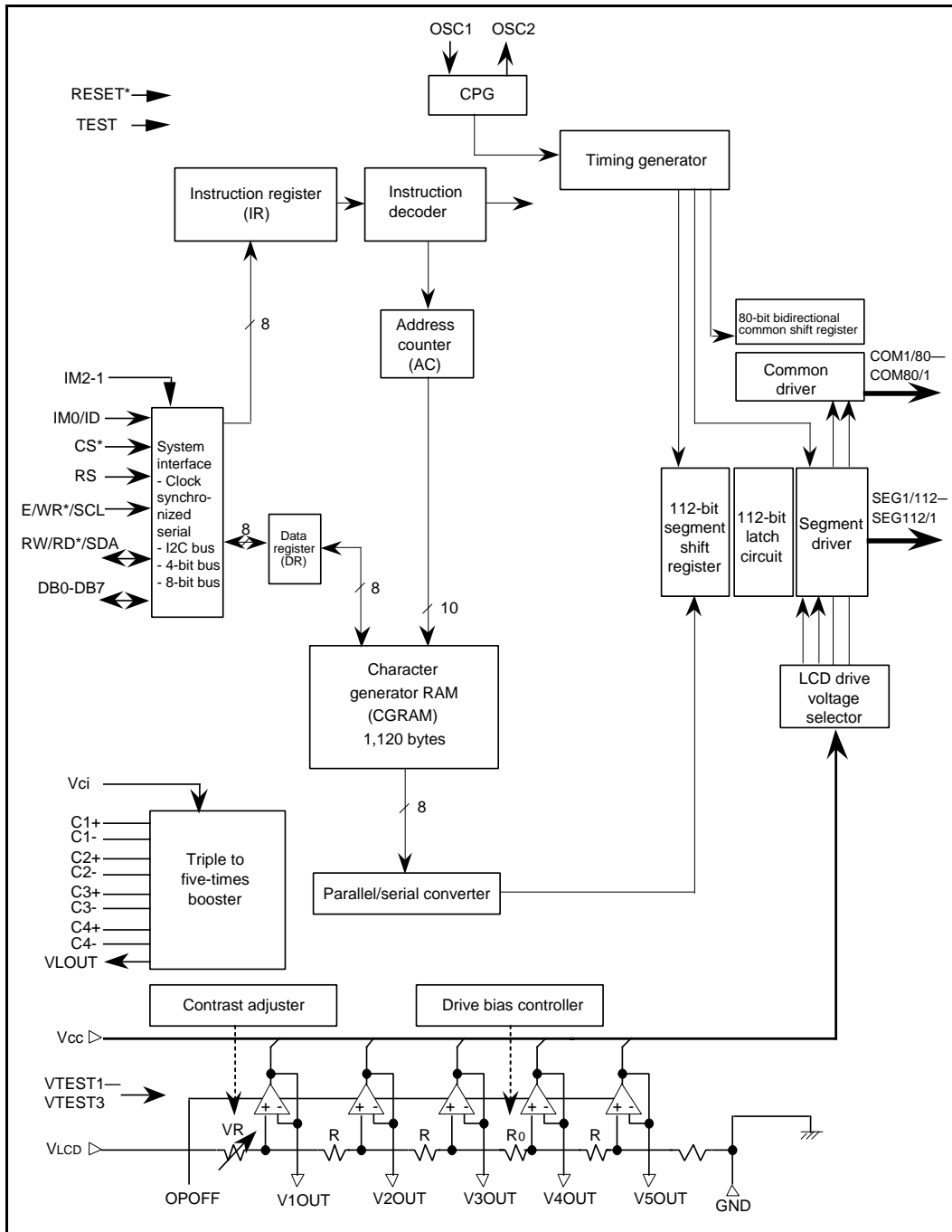

HITACHI

HD66740 Pad Coordinate

2000.06.13 (Unit : um)

No.	PAD NAME	X	Y	No.	PAD NAME	X	Y	No.	PAD NAME	X	Y	No.	PAD NAME	X	Y
1	DUMMY1	-4538	-930	73	V5OUT	3834	-930	145	SEG18/95	1930	928	217	SEG90/23	-1679	928
2	GNDDUM	-4336	-930	74	VTEST1	3936	-930	146	SEG19/94	1880	928	218	SEG91/22	-1729	928
3	IM2	-4190	-930	75	VTEST2	4038	-930	147	SEG20/93	1829	928	219	SEG92/21	-1779	928
4	IM1	-4045	-930	76	VTEST3	4140	-930	148	SEG21/92	1779	928	220	SEG93/20	-1829	928
5	IM0/ID	-3915	-930	77	GNDDUM2	4336	-930	149	SEG22/91	1729	928	221	SEG94/19	-1880	928
6	VCCDUM	-3813	-930	78	DUMMY2	4538	-930	150	SEG23/90	1679	928	222	SEG95/18	-1930	928
7	OPOFF	-3711	-930	79	COM9/72	4538	-721	151	SEG24/89	1629	928	223	SEG96/17	-1980	928
8	TEST	-3609	-930	80	COM10/71	4538	-661	152	SEG25/88	1579	928	224	SEG97/16	-2030	928
9	DB7	-3466	-930	81	COM11/70	4538	-601	153	SEG26/87	1529	928	225	SEG98/15	-2080	928
10	DB6	-3321	-930	82	COM12/69	4538	-541	154	SEG27/86	1479	928	226	SEG99/14	-2130	928
11	DB5	-3177	-930	83	COM13/68	4538	-481	155	SEG28/85	1428	928	227	SEG100/13	-2180	928
12	DB4	-3032	-930	84	COM14/67	4538	-421	156	SEG29/84	1378	928	228	SEG101/12	-2230	928
13	DB3	-2887	-930	85	COM15/66	4538	-361	157	SEG30/83	1328	928	229	SEG102/11	-2281	928
14	DB2	-2742	-930	86	COM16/65	4538	-301	158	SEG31/82	1278	928	230	SEG103/10	-2331	928
15	DB1	-2597	-930	87	COM17/64	4538	-240	159	SEG32/81	1228	928	231	SEG104/9	-2381	928
16	DB0	-2453	-930	88	COM18/63	4538	-180	160	SEG33/80	1178	928	232	SEG105/8	-2431	928
17	RESET*	-2308	-930	89	COM19/62	4538	-120	161	SEG34/79	1128	928	233	SEG106/7	-2481	928
18	CS*	-2163	-930	90	COM20/61	4538	-60	162	SEG35/78	1078	928	234	SEG107/6	-2531	928
19	RS	-2018	-930	91	COM21/60	4538	0	163	SEG36/77	1028	928	235	SEG108/5	-2581	928
20	EWR*/SCL	-1873	-930	92	COM22/59	4538	60	164	SEG37/76	977	928	236	SEG109/4	-2631	928
21	RWRD*/SDA	-1729	-930	93	COM23/58	4538	120	165	SEG38/75	927	928	237	SEG110/3	-2682	928
22	GND	-1627	-930	94	COM24/57	4538	180	166	SEG39/74	877	928	238	SEG111/2	-2732	928
23	GND	-1525	-930	95	COM25/56	4538	240	167	SEG40/73	827	928	239	SEG112/1	-2782	928
24	GND	-1423	-930	96	COM26/55	4538	301	168	SEG41/72	777	928	240	DUMMY12	-2836	928
25	GND	-1321	-930	97	COM27/54	4538	361	169	SEG42/71	727	928	241	DUMMY13	-2891	928
26	GND	-1219	-930	98	COM28/53	4538	421	170	SEG43/70	677	928	242	DUMMY14	-3041	928
27	OSC2	-1117	-930	99	COM29/52	4538	481	171	SEG44/69	627	928	243	DUMMY15	-3101	928
28	OSC1	-972	-930	100	COM30/51	4538	541	172	SEG45/68	576	928	244	DUMMY16	-3161	928
29	VCC	-791	-930	101	COM31/50	4538	601	173	SEG46/67	526	928	245	DUMMY17	-3221	928
30	VCC	-689	-930	102	COM32/49	4538	661	174	SEG47/66	476	928	246	DUMMY18	-3281	928
31	VCC	-587	-930	103	COM33/48	4538	721	175	SEG48/65	426	928	247	DUMMY19	-3341	928
32	VCC	-485	-930	104	DUMMY3	4538	928	176	SEG49/64	376	928	248	COM72/9	-3495	928
33	VCI	-332	-930	105	COM34/47	4336	928	177	SEG50/63	326	928	249	COM71/10	-3555	928
34	VCI	-230	-930	106	COM35/46	4276	928	178	SEG51/62	276	928	250	COM70/11	-3615	928
35	VCI	-128	-930	107	COM36/45	4216	928	179	SEG52/61	226	928	251	COM69/12	-3675	928
36	VCI	-26	-930	108	COM37/44	4156	928	180	SEG53/60	175	928	252	COM68/13	-3735	928
37	C4+	76	-930	109	COM38/43	4096	928	181	SEG54/59	125	928	253	COM67/14	-3795	928
38	C4+	178	-930	110	COM39/42	4036	928	182	SEG55/58	75	928	254	COM66/15	-3856	928
39	C4+	280	-930	111	COM40/41	3976	928	183	SEG56/57	25	928	255	COM65/16	-3916	928
40	C4-	381	-930	112	COM73/8	3916	928	184	SEG57/56	-25	928	256	COM64/17	-3976	928
41	C4-	483	-930	113	COM74/7	3856	928	185	SEG58/55	-75	928	257	COM63/18	-4036	928
42	C4-	585	-930	114	COM75/6	3795	928	186	SEG59/54	-125	928	258	COM62/19	-4096	928
43	C3+	687	-930	115	COM76/5	3735	928	187	SEG60/53	-175	928	259	COM61/20	-4156	928
44	C3+	789	-930	116	COM77/4	3675	928	188	SEG61/52	-226	928	260	COM60/21	-4216	928
45	C3+	891	-930	117	COM78/3	3615	928	189	SEG62/51	-276	928	261	COM59/22	-4276	928
46	C3-	993	-930	118	COM79/2	3555	928	190	SEG63/50	-326	928	262	COM58/23	-4336	928
47	C3-	1095	-930	119	COM80/1	3495	928	191	SEG64/49	-376	928	263	DUMMY20	-4538	928
48	C3-	1197	-930	120	DUMMY4	3431	928	192	SEG65/48	-426	928	264	COM57/24	-4538	721
49	C2+	1299	-930	121	DUMMY5	3361	928	193	SEG66/47	-476	928	265	COM56/25	-4538	661
50	C2+	1401	-930	122	DUMMY6	3221	928	194	SEG67/46	-526	928	266	COM55/26	-4538	601
51	C2+	1503	-930	123	DUMMY7	3161	928	195	SEG68/45	-576	928	267	COM54/27	-4538	541
52	C2-	1605	-930	124	DUMMY8	3101	928	196	SEG69/44	-627	928	268	COM53/28	-4538	481
53	C2-	1707	-930	125	DUMMY9	3041	928	197	SEG70/43	-677	928	269	COM52/29	-4538	421
54	C2-	1809	-930	126	DUMMY10	2981	928	198	SEG71/42	-727	928	270	COM51/30	-4538	361
55	C1+	1911	-930	127	DUMMY11	2836	928	199	SEG72/41	-777	928	271	COM50/31	-4538	301
56	C1+	2013	-930	128	SEG1/12	2782	928	200	SEG73/40	-827	928	272	COM49/32	-4538	240
57	C1+	2115	-930	129	SEG2/11	2732	928	201	SEG74/39	-877	928	273	COM48/33	-4538	180
58	C1-	2217	-930	130	SEG3/10	2682	928	202	SEG75/38	-927	928	274	COM47/34	-4538	120
59	C1-	2319	-930	131	SEG4/09	2631	928	203	SEG76/37	-977	928	275	COM46/35	-4538	60
60	C1-	2421	-930	132	SEG5/08	2581	928	204	SEG77/36	-1028	928	276	COM45/36	-4538	0
61	V1OUT	2523	-930	133	SEG6/07	2531	928	205	SEG78/35	-1078	928	277	COM44/37	-4538	-60
62	V1OUT	2625	-930	134	SEG7/06	2481	928	206	SEG79/34	-1128	928	278	COM43/38	-4538	-120
63	V1OUT	2727	-930	135	SEG8/05	2431	928	207	SEG80/33	-1178	928	279	COM42/39	-4538	-180
64	V1OUT	2829	-930	136	SEG9/04	2381	928	208	SEG81/32	-1228	928	280	COM41/40	-4538	-240
65	V1CD	2930	-930	137	SEG10/03	2331	928	209	SEG82/31	-1278	928	281	COM8/73	-4538	-301
66	V1CD	3032	-930	138	SEG11/02	2281	928	210	SEG83/30	-1328	928	282	COM7/74	-4538	-361
67	V1CD	3134	-930	139	SEG12/01	2230	928	211	SEG84/29	-1378	928	283	COM6/75	-4538	-421
68	V1CD	3236	-930	140	SEG13/00	2180	928	212	SEG85/28	-1428	928	284	COM5/76	-4538	-481
69	V1OUT	3426	-930	141	SEG14/99	2130	928	213	SEG86/27	-1479	928	285	COM4/77	-4538	-541
70	V2OUT	3528	-930	142	SEG15/98	2080	928	214	SEG87/26	-1529	928	286	COM3/78	-4538	-601
71	V3OUT	3630	-930	143	SEG16/97	2030	928	215	SEG88/25	-1579	928	287	COM2/79	-4538	-661
72	V4OUT	3732	-930	144	SEG17/96	1980	928	216	SEG89/24	-1629	928	288	COM1/80	-4538	-721

HD66740

TCP Dimensions (HD66740TB0)

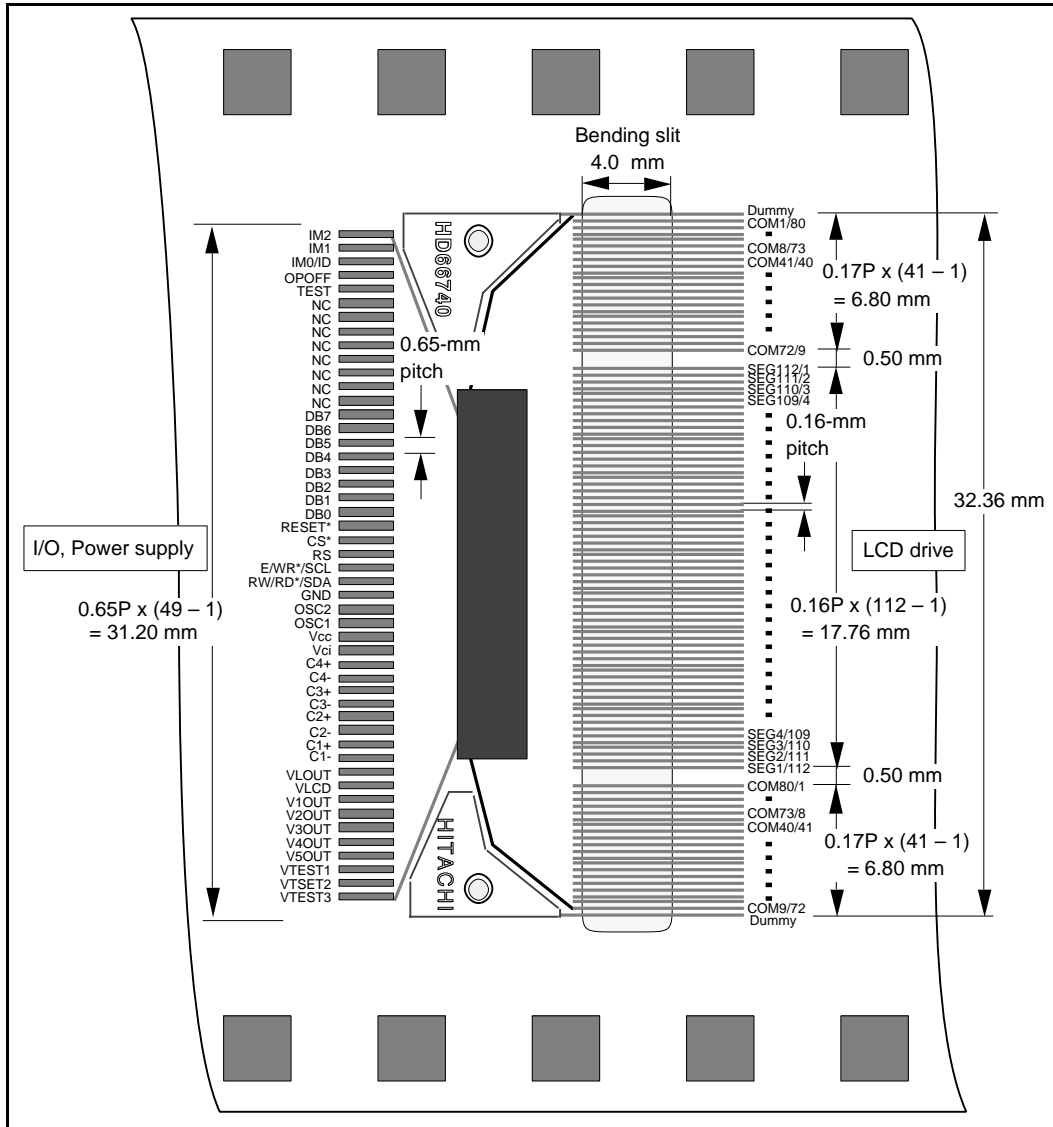

HITACHI

Pin Functions

Table 2 Pin Functional Description

Signals	Number of Pins	I/O	Connected to	Functions															
IM2, IM1	2	I	GND or V _{CC}	<p>Selects the MPU interface mode:</p> <table border="1"> <thead> <tr> <th>IM2</th> <th>IM1</th> <th>MPU interface mode</th> </tr> </thead> <tbody> <tr> <td>"GND"</td> <td>"GND"</td> <td>Clock synchronized serial interface</td> </tr> <tr> <td>"GND"</td> <td>"Vcc"</td> <td>68-system parallel interface</td> </tr> <tr> <td>"Vcc"</td> <td>"GND"</td> <td>I2C bus interface</td> </tr> <tr> <td>"Vcc"</td> <td>"Vcc"</td> <td>80-system parallel interface</td> </tr> </tbody> </table>	IM2	IM1	MPU interface mode	"GND"	"GND"	Clock synchronized serial interface	"GND"	"Vcc"	68-system parallel interface	"Vcc"	"GND"	I2C bus interface	"Vcc"	"Vcc"	80-system parallel interface
IM2	IM1	MPU interface mode																	
"GND"	"GND"	Clock synchronized serial interface																	
"GND"	"Vcc"	68-system parallel interface																	
"Vcc"	"GND"	I2C bus interface																	
"Vcc"	"Vcc"	80-system parallel interface																	
IM0/ID	1	I	GND or V _{CC}	<p>Selects the transfer bus length for a parallel bus interface. GND: 8-bit bus, Vcc: 4-bit bus Inputs the ID of the device ID code for a serial bus and I2C bus interface.</p>															
CS*	1	I	MPU	<p>Selects the HD66740: Low: HD66740 is selected and can be accessed High: HD66740 is not selected and cannot be accessed Must be fixed at GND level when not in use.</p>															
RS	1	I	MPU	<p>Selects the register for a parallel bus interface. Low: Instruction High: RAM access Must be fixed at GND level when not in use.</p>															
E/WR*/SCL	1	I	MPU	<p>For an 80-system parallel bus interface, serves as a write strobe signal and writes data at the low level. For a 68-system parallel bus interface, serves as an enable signal to activate data read/write operation. Inputs the serial transfer clock for a serial interface. Fetches data at the rising edge of a clock.</p>															
RW/RD*/SDA	1	I or I/O	MPU	<p>For an 80-system parallel bus interface, serves as a write strobe signal and reads data at the low level. For a 68-system parallel bus interface, serves as a signal to select data read/write operation. Low: Write High: Read Serves as the bidirectional serial transfer data for a serial interface. Sends/Receives data.</p>															

HD66740

Table 2 Pin Functional Description (cont)

Signals	Number of Pins	I/O	Connected to	Functions
DB0–DB7	8	I/O or I	MPU	Serves as a bidirectional data bus for a parallel bus interface. For a 4-bit bus, data transfer uses DB7-DB4 Must be fixed at GND level when serial interface mode is used.
COM1/80– COM80/1	80	O	LCD	Common output signals for graphics display: COM1 to COM8 for the first line, COM9 to COM16 for the second line, COM17 to COM24 for the third line, COM25 to COM32 for the fourth line, and COM73 to COM80 for the 10th line. All the unused pins output unselected waveforms. In the sleep mode (SLP = 1) or standby mode (STB = 1), all pins output GND level. The CMS bit can change the shift direction of the common signal. For example, if CMS = 0, COM1/80 is COM1. If CMS = 1, COM1/80 is COM80. Note that the start position of the common output (the first line) is shifted by CN1–CN0 bits.
SEG1/112– SEG112/1	112	O	LCD	Segment output signals for graphics display. In the sleep mode (SLP = 1) or standby mode (STB = 1), all pins output GND level. The SGS bit can change the shift direction of the segment signal. For example, if SGS = 0, SEG1/112 is SEG1. If SGS = 1, SEG1/112 is SEG112.
V1OUT–V5 OUT	5	I or O	Open or external bleeder-resistor	Used for output from the internal operational amplifiers when they are used (OPOFF = GND); attach a capacitor to stabilize the output. When the amplifiers are not used (OPOFF = V_{CC}), V1 to V5 voltages can be supplied to these pins externally.
V_{LCD}	3	—	Power supply	Power supply for LCD drive. $V_{LCD} - GND = 15 V$ max.
V_{CC} , GND	12	—	Power supply	V_{CC} : +1.8 V to +3.6 V; GND (logic): 0 V
OSC1, OSC2	2	I or O	Oscillation-resistor or clock	For R-C oscillation using an external resistor, connect an external resistor. For external clock supply, input clock pulses to OSC1.
Vci	5	I	Power supply	Inputs a reference voltage and supplies power to the booster; generates the liquid crystal display drive voltage from the operating voltage. The boosting output voltage must not be larger than the absolute maximum ratings. Must be left disconnected when the booster is not used.
VLOUT	3	O	V_{LCD} pin/booster capacitance	Potential difference between Vci and GND is triple- to five-times-boosted and then output. Magnitude of boost is selected by instruction.

Table 2 Pin Functional Description (cont)

Signals	Number of Pins	I/O	Connected to	Functions
C1+, C1-	8	—	Booster capacitance	External capacitance should be connected here for boosting.
C2+, C2-	6	—	Booster capacitance	External capacitance should be connected here when using the triple or more booster.
C3+, C3-	6	—	Booster capacitance	External capacitance should be connected here when using the quadruple and five-times booster.
C4+, C4-	6	—	Booster capacitance	External capacitance should be connected here when using the five-times booster.
RESET*	1	I	MPU or external R-C circuit	Reset pin. Initializes the LSI when low.
OPOFF	1	I	V _{cc} or GND	Turns the internal operational amplifier off when OPOFF = V _{cc} , and turns it on when OPOFF = GND. If the amplifier is turned off (OPOFF = V _{cc}), V1 to V5 must be supplied to the V1OUT to V5OUT pins.
VccDUM	1	O	Input pins	Outputs the internal V _{cc} level; shorting this pin sets the adjacent input pin to the V _{cc} level.
GNDDUM	1	O	Input pins	Outputs the internal GND level; shorting this pin sets the adjacent input pin to the GND level.
Dummy	5	—	—	Dummy pad. Must be left disconnected.
TEST	1	I	GND	Test pin. Must be fixed at GND level.
VTEST1	1	I	GND or V _{cc}	Adjusts the driving capability of the internal operational amplifier for the LCD. This signal enters the normal drive mode in the GND side, and it enters the high-power drive mode in the V _{cc} side. When the display quality is not sufficient, use the high-power drive mode even though the power-consumption current is large.
VTEST2	1	—	—	Test pin. Must be left disconnected.
VTEST3	1	I	V _{cc} or GND	Adjusts the driving capability of the internal operational amplifier for the LCD. This signal enters the normal drive mode or high-power mode in the GND side according to the VTEST1 pin setting, and it enters the low-power drive mode in the V _{cc} side. Use this signal in the low-power mode so that the display quality is not lowered.

HD66740

Block Function Description

System Interface

The HD66740 has six types of system interfaces, and a clock-synchronized serial, an I2C bus interface, a 68-system 4-bit/8-bit bus, and a 80-system 4-bit/8-bit bus. The interface mode is selected by the IM2-0 pins.

The HD66740 has two 8-bit registers: an instruction register (IR) and a data register (DR).

The IR stores instruction codes, such as clear display, display control, and address information for the display character generator RAM (CGRAM).

The DR temporarily stores data to be written into the CGRAM. Data written into the DR from the MPU is automatically written into the CGRAM by internal operation. When address information is written into the IR, data is read and then stored in the DR from the CGRAM by internal operation. Data is read through the DR when reading from the RAM, and the first read data is invalid and the second and the following data are normal. After reading, data in the CGRAM at the next address is sent to the DR for the next reading from the MPU.

Execution time for instruction excluding clear display is 0 clock cycle and instructions can be written in succession.

Table 3 Register Selection by RS and R/W Bits

R/W Bit	RS Bit	Operations
0	0	Write instructions to IR
1	0	-
0	1	DR write as an internal operation (DR to CGRAM)
1	1	DR read as an internal operation (CGRAM to DR)

Address Counter (AC)

The address counter (AC) assigns addresses to the CGRAM. When an address set instruction is written into the IR, the address information is sent from the IR to the AC.

After writing into the CGRAM, the AC is automatically incremented by 1 (or decremented by 1). After reading from the data, the RDM bit automatically updates or does not update the AC.

Character Generator RAM (CGRAM)

The CGRAM serves as a RAM to store 112 x 80-dot bit pattern data in the graphics display mode. Here, display patterns are directly written into CGRAM. For details, see the Graphics Display section.

Timing Generator

The timing generator generates timing signals for the operation of internal circuits such as the CGRAM. The RAM read timing for display and internal operation timing by MPU access are generated separately to avoid interference with one another. This prevents flickering in areas other than the display area when writing data to the CGRAM, for example.

Oscillation Circuit (OSC)

The HD66740 can provide R-C oscillation simply through the addition of an external oscillation-resistor between the OSC1 and OSC2 pins. The appropriate oscillation frequency for operating voltage, display size, and frame frequency can be obtained by adjusting the external-resistor value. Clock pulses can also be supplied externally. Since R-C oscillation stops during the standby mode, current consumption can be reduced. For details, see the Oscillation circuit section.

Liquid Crystal Display Driver Circuit

The liquid crystal display driver circuit consists of 80 common signal drivers (COM1 to COM80) and 112 segment signal drivers (SEG1 to SEG112). When the number of lines are selected by a program, the required common signal drivers automatically output drive waveforms, while the other common signal drivers continue to output unselected waveforms.

Graphics data is sent serially through a 112-bit shift register and latched when all needed data has arrived. The latched data then enables the segment signal drivers to generate drive waveform outputs.

The shift direction of 112-bit data can be changed by the SGS bit. The shift direction for the common driver can also be changed by the CMS bit by selecting an appropriate direction for the device mounting configuration.

When display is off, or during the standby or sleep mode, all the above common and segment signal drivers output the GND level, halting the display.

Booster (DC-DC Converter)

The booster generates triple, quadruple, or five-times voltage input to the Vci pin. With this, both the internal logic units and LCD drivers can be controlled with a single power supply. Boost output level from triple to five-times boost can be selected by software. For details, see the Power Supply for Liquid Crystal Display Drive section.

V-Pin Voltage Follower

A voltage follower for each voltage level (V1 to V5) reduces current consumption by the LCD drive power supply circuit. No external resistors are required because of the internal bleeder-resistor, which generates different levels of LCD drive voltage. This internal bleeder-resistor can be software-specified from 1/4 bias to 1/10 bias, according to the liquid crystal display drive duty value. The voltage followers can be turned off while multiplexing drive is not being used. For details, see the Power Supply for Liquid Crystal Display Drive section.

Contrast Adjuster

The contrast adjuster can be used to adjust LCD contrast in 64 steps by varying the LCD drive voltage by software. This can be used to select an appropriate LCD brightness or to compensate for temperature.

HD66740

CGRAM Address Map

Table 4 Relationship between Display Position and CGRAM Address (1)

Segment Driver	SEG1/112	SEG2/111	SEG3/110	SEG4/109	SEG5/108	SEG6/107	SEG7/106	SEG8/105	SEG9/104	SEG10/103	SEG11/102	SEG12/101	SEG13/100	SEG14/99	SEG15/98	SEG16/97	SEG17/96	...	SEG108/5	SEG109/4	SEG110/3	SEG111/2	SEG112/1	Segment Common	
	Address	SGS="0"	000	001	002	003	004	005	006	007	008	009	00A	00B	00C	00D	00E	00F	010	...	06B	06C	06D	06E	06F
	SGS="1"	06F	06E	06D	06C	06B	06A	069	068	067	066	065	064	063	062	061	060	05F	...	004	003	002	001	000	
	DB0	0	0	0	0	0	0	0	0	1	0	0	0	0	0	0	0	0	...	0	0	1	0	0	COM1
	DB1	0	1	1	1	1	1	1	1	1	1	1	1	1	1	1	0	0	...	0	1	1	0	0	COM2
	DB2	0	0	0	0	0	0	0	0	1	0	0	0	0	0	0	0	0	...	0	0	1	0	0	COM3
	DB3	0	0	0	1	1	1	1	1	1	1	1	1	1	0	0	0	0	...	0	0	1	0	0	COM4
	DB4	0	0	0	1	0	0	0	0	1	0	0	0	0	1	0	0	0	...	0	0	1	0	0	COM5
	DB5	0	0	0	1	0	0	0	0	1	0	0	0	0	1	0	0	0	...	0	0	1	0	0	COM6
	DB6	0	0	0	1	1	1	1	1	1	1	1	1	1	0	0	0	0	...	0	1	1	1	0	COM7
	DB7	0	0	0	1	0	0	0	0	1	0	0	0	0	1	0	0	0	...	0	0	0	0	0	COM8
Address	SGS="0"	080	081	082	083	084	085	086	087	088	089	08A	08B	08C	08D	08E	08F	090	...	0EB	0EC	0ED	0EE	0EF	(HEX)
	SGS="1"	0EF	0EE	0ED	0EC	0EB	0EA	0E9	0E8	0E7	0E6	0E5	0E4	0E3	0E2	0E1	0E0	0DF	...	084	083	082	081	080	
	DB0	0	0	0	1	0	0	0	0	1	0	0	0	0	1	0	0	0	...	0	1	1	1	0	COM9
	DB1	0	0	0	1	1	1	1	1	1	1	1	1	1	0	0	0	0	...	1	0	0	0	1	COM10
	DB2	0	0	0	0	0	0	1	0	1	0	0	0	0	0	0	0	0	...	0	0	0	0	1	COM11
	DB3	0	0	0	0	0	1	0	0	1	0	0	0	0	0	0	0	0	...	0	0	0	1	0	COM12
	DB4	0	0	0	0	1	0	0	0	1	0	0	0	0	1	0	0	0	...	0	0	1	0	0	COM13
	DB5	0	0	0	1	0	0	0	0	1	0	0	0	0	1	0	0	0	...	0	0	1	0	0	COM14
	DB6	0	1	1	0	0	0	0	0	1	0	0	0	0	1	1	0	0	...	1	1	1	1	1	COM15
	DB7	0	0	0	0	0	0	0	0	0	0	0	0	0	0	0	0	0	...	0	0	0	0	0	COM16
Address	SGS="0"	100	101	102	103	104	105	106	107	108	109	10A	10B	10C	10D	10E	10F	110	...	16B	16C	16D	16E	16F	(HEX)
	SGS="1"	16F	16E	16D	16C	16B	16A	169	168	167	166	165	164	163	162	161	160	15F	...	104	103	102	101	100	
	DB0	0	0	0	0	0	0	0	0	0	0	0	0	0	0	0	0	0	...	1	1	1	1	1	COM17
	DB1	0	0	0	1	1	1	1	1	1	1	1	1	1	1	0	0	0	...	0	0	0	1	0	COM18

	DB7	0	0	0	1	1	1	1	1	1	1	1	1	1	0	0	0	0	...	0	0	0	0	0	COM24
Address	SGS="0"	180	181	182	183	184	185	186	187	188	189	18A	18B	18C	18D	18E	18F	180	...	1EB	1EC	1ED	1EE	1EF	(HEX)
	SGS="1"	1EF	1EE	1ED	1EC	1EB	1EA	1E9	1E8	1E7	1E6	1E5	1E4	1E3	1E2	1E1	1E0	1DF	...	184	183	182	181	180	
	DB0	0	0	0	1	0	0	0	0	0	0	0	0	0	1	0	0	0	...	0	0	0	1	0	COM25
	DB1	0	0	0	1	0	0	0	0	0	0	0	0	0	1	0	0	0	...	0	0	1	1	0	COM26

	DB7	0	0	0	0	0	0	0	0	0	0	0	0	0	0	0	0	0	...	0	0	0	0	0	COM32
Address	SGS="0"	200	201	202	203	204	205	206	207	208	209	20A	20B	20C	20D	20E	20F	210	...	26B	26C	26D	26E	26F	(HEX)
	SGS="1"	26F	26E	26D	26C	26B	26A	269	268	267	266	265	264	263	262	261	260	25F	...	204	203	202	201	200	
	DB0	0	0	0	1	0	0	0	0	0	0	0	0	0	1	0	0	0	...	0	0	0	1	0	COM33
	DB1	0	0	0	1	0	0	0	0	0	0	0	0	0	1	0	0	0	...	0	0	1	1	0	COM34

	DB7	0	0	0	0	0	0	0	0	0	0	0	0	0	0	0	0	0	...	0	0	0	0	0	COM40

Notes: 1. A set bit in CGRAM data 1 corresponds to display selection (lit) and 0 to non-selection (unlit).

Table 5 Relationship between Display Position and CGRAM Address (2)

Segment Driver	SEG1/12	SEG2/11	SEG3/10	SEG4/09	SEG5/08	SEG6/07	SEG7/06	SEG8/05	SEG9/04	SEG10/03	SEG11/02	SEG12/01	SEG13/00	SEG14/99	SEG15/98	SEG16/97	SEG17/96	...	SEG108/5	SEG109/4	SEG110/3	SEG111/2	SEG112/1	Segment Common																																									
	Address	SGS="0"	SGS="1"	DB0	DB1	DB2	DB3	DB4	DB5	DB6	DB7	Address	SGS="0"	SGS="1"	DB0	DB1	DB2	DB3	DB4	DB5	DB6	DB7	Address	SGS="0"	SGS="1"	DB0	DB1	DB2	DB3	DB4	DB5	DB6	DB7	Address	SGS="0"	SGS="1"	DB0	DB1	DB2	DB3	DB4	DB5	DB6	DB7	Address	SGS="0"	SGS="1"	DB0	DB1	DB2	DB3	DB4	DB5	DB6	DB7	Address	SGS="0"	SGS="1"	DB0	DB1	DB2	DB3	DB4	DB5	DB6
	280	281	282	283	284	285	286	287	288	289	28A	28B	28C	28D	28E	28F	290	...	2EB	2EC	2ED	2EE	2EF	(HEX)																																									
	2EF	2EE	2ED	2EC	2EB	2EA	2E9	2E8	2E7	2E6	2E5	2E4	2E3	2E2	2E1	2E0	2DF	...	284	283	282	281	280	(HEX)																																									
	0	1	1	0	0	0	1	1	0	0	0	1	1	1	1	1	...	1	1	1	1	1	COM41																																										
	1	1	1	1	0	1	1	1	1	0	1	0	0	0	0	0	1	...	0	0	0	1	0	COM42																																									
	1	1	1	1	1	1	1	1	1	0	0	0	1	0	1	0	...	0	1	1	0	0	COM43																																										
	1	1	1	1	1	1	1	1	1	0	0	1	1	1	1	0	...	0	0	0	1	0	COM44																																										
	1	1	1	1	1	1	1	1	1	0	1	1	1	0	1	1	...	0	0	0	0	1	COM45																																										
	0	1	1	1	1	1	1	1	0	0	1	1	0	0	1	1	...	1	0	0	0	1	COM46																																										
	0	0	1	1	1	1	0	0	0	0	1	1	1	0	1	1	...	0	1	1	1	0	COM47																																										
	0	0	0	1	1	1	0	0	0	0	0	1	1	1	1	0	...	0	0	0	0	0	COM48																																										
	300	301	302	303	304	305	306	307	308	309	30A	30B	30C	30D	30E	30F	310	...	36B	36C	36D	36E	36F	(HEX)																																									
	36F	36E	36D	36C	36B	36A	369	368	367	366	365	364	363	362	361	360	35F	...	304	303	302	301	300	(HEX)																																									
	0	0	0	0	0	0	0	0	0	0	0	1	1	1	1	1	...	1	1	1	1	1	COM49																																										
	0	0	0	1	0	1	0	0	0	0	1	0	0	0	0	0	1	...	1	0	0	0	0	COM50																																									
	0	0	1	1	1	1	1	0	0	0	0	0	1	0	1	0	...	1	1	1	1	0	COM51																																										
	0	1	1	1	1	1	1	0	0	0	1	1	1	1	1	0	...	0	0	0	0	1	COM52																																										
	0	0	1	1	1	1	0	0	0	0	1	1	1	0	1	1	...	0	0	0	0	1	COM53																																										
	0	0	0	1	1	1	0	0	0	0	1	1	0	0	0	1	...	1	0	0	0	1	COM54																																										
	0	0	0	0	1	0	0	0	0	0	1	1	1	0	1	1	...	0	1	1	1	0	COM55																																										
	0	0	0	0	0	0	0	0	0	0	0	1	1	1	1	0	...	0	0	0	0	0	COM56																																										
	380	381	382	383	384	385	386	387	388	389	38A	38B	38C	38D	38E	38F	390	...	3EB	3EC	3ED	3EE	3EF	(HEX)																																									
	3EF	3EE	3ED	3EC	3EB	3EA	3E9	3E8	3E7	3E6	3E5	3E4	3E3	3E2	3E1	3E0	3DF	...	384	383	382	381	380	(HEX)																																									
	0	0	0	0	0	0	0	0	0	0	0	1	1	1	1	1	...	0	0	1	0	0	COM57																																										
	0	0	0	1	0	1	0	0	0	0	1	0	0	0	0	0	1	...	0	1	1	0	0	COM58																																									
	0	0	0	0	0	0	0	0	0	0	0	0	0	0	0	0	...	0	0	0	0	0	COM59																																										
	0	0	0	0	1	1	1	0	0	0	0	1	1	1	1	0	...	0	0	0	0	0	COM60																																										
	0	0	0	0	1	1	1	0	0	0	0	1	1	1	1	0	...	0	0	0	0	0	COM61																																										
	0	0	0	0	0	0	0	0	0	0	0	1	1	1	1	1	...	0	0	0	0	0	COM62																																										
	0	0	0	0	0	0	0	0	0	0	0	1	1	1	1	1	...	0	0	0	0	0	COM63																																										
	0	1	1	0	0	0	1	1	0	0	0	1	1	1	1	1	...	0	1	1	1	0	COM64																																										
	1	1	1	1	0	1	1	1	1	0	1	0	0	0	0	0	1	...	1	0	0	0	1	COM65																																									
	0	0	0	0	0	0	0	0	0	0	0	0	0	0	0	0	...	0	0	0	0	0	COM66																																										
	0	0	0	1	1	1	0	0	0	0	0	1	1	1	1	0	...	0	0	0	0	0	COM67																																										
	0	0	0	1	1	1	0	0	0	0	0	1	1	1	1	0	...	0	0	0	0	0	COM68																																										
	0	0	0	0	0	0	0	0	0	0	0	0	0	0	0	0	...	0	0	0	0	0	COM69																																										
	0	0	0	0	0	0	0	0	0	0	0	0	0	0	0	0	...	0	0	0	0	0	COM70																																										
	0	1	1	0	0	0	1	1	0	0	0	1	1	1	1	1	...	0	1	1	1	0	COM71																																										
	1	1	1	1	0	1	1	1	1	0	1	0	0	0	0	0	1	...	1	0	0	0	1	COM72																																									
	0	0	0	0	0	0	0	0	0	0	0	0	0	0	0	0	...	0	0	0	0	0	COM73																																										
	0	1	1	0	0	0	1	1	0	0	0	1	1	1	1	1	...	0	1	1	1	0	COM74																																										
	1	1	1	1	0	1	1	1	1	0	1	0	0	0	0	0	1	...	1	0	0	0	1	COM75																																									
	0	0	0	1	1	1	0	0	0	0	0	1	1	1	1	0	...	0	0	0	0	0	COM76																																										
	0	0	0	1	1	1	0	0	0	0	0	1	1	1	1	0	...	0	0	0	0	0	COM77																																										
	0	0	0	0	0	0	0	0	0	0	0	0	0	0	0	0	...	0	0	0	0	0	COM78																																										
	0	0	0	0	0	0	0	0	0	0	0	0	0	0	0	0	...	0	0	0	0	0	COM79																																										
	0	0	0	0	0	0	0	0	0	0	0	0	0	0	0	0	...	0	0	0	0	0	COM80																																										

Notes: 1. A set bit in CGRAM data 1 corresponds to display selection (lit) and 0 to non-selection (unlit).

HD66740

Instructions

Outline

Only the instruction register (IR) and the data register (DR) of the HD66740 can be controlled by the MPU. Before starting internal operation of the HD66740, control information is temporarily stored in these registers to allow interfacing with various peripheral control devices or MPUs which operate at different speeds. The internal operation of the HD66740 is determined by signals sent from the MPU. These signals, which include the register selection signal (RS), the read/write signal (R/W), and the data bus signal (DB0 to DB7), make up the HD66740 instructions. There are four categories of instructions that:

- Control the display
- Control power management
- Set internal RAM addresses
- Transfer data with the internal RAM

Normally, instructions that perform data transfer with the internal RAM are used the most. However, auto-incrementation by 1 (or auto-decrementation by 1) of internal HD66740 RAM addresses after each data write can lighten the MPU program load.

Because instructions are executed in 0 cycle, instructions can be written in succession.

Instruction Descriptions

Start Oscillation

The start oscillation instruction restarts the oscillator from the halt state in the standby mode. After issuing this instruction, wait at least 10 ms for oscillation to stabilize before issuing the next instruction. (See the Standby Mode section.)

R/W	RS	DB7	DB6	DB5	DB4	DB3	DB2	DB1	DB0
0	0	0	0	0	0	0	0	1	1

Figure 1 Start Oscillation Instruction

Driver Output Control

CMS: Selects the output shift direction of a common driver. When CMS = "0", COM1/80 shifts to COM1, and COM80/1 to COM80. When CMS = "1", COM1/80 shifts to COM80, and COM80/1 to COM1. Output position of a common driver shifts depending on the CN1–0 bit setting. For details, see the Display On/Off Control section.

SGS: Selects the output shift direction of a segment driver. When SGS = "0", SEG1/112 shifts to SEG1, and SEG112/1 to SEG112. When SGS = "1", SEG1/112 shifts SEG112, and SEG112/1 to SEG1.

R/W	RS	DB7	DB6	DB5	DB4	DB3	DB2	DB1	DB0
0	0	0	0	0	0	0	1	CMS	SGS

Figure 2 Driver Output Control Instruction

HD66740

Power Control

AMP: When AMP = 1, each voltage follower for V1 to V5 pins and the booster are turned on. When AMP = 0, current consumption can be reduced while the display is not being used.

SLP: When SLP = 1, the HD66740 enters the sleep mode, where the internal operations are halted except for the R-C oscillator, thus reducing current consumption. For details, see the Sleep Mode section. Only the power control (AMP, SLP, and STB bits) instruction can be executed during the sleep mode.

During the sleep mode, the other RAM data and instructions cannot be updated although they are retained.

STB: When STB = 1, the HD66740 enters the standby mode, where display operation completely stops, halting all the internal operations including the internal R-C oscillator. Further, no external clock pulses are supplied. For details, see the Standby Mode section.

Only the following instructions can be executed during the standby mode.

- a. Standby mode cancel (STB = 0)
- b. Voltage follower circuit on/off (AMP = 1/0)
- c. Start oscillation

During the standby mode, the other RAM data and instructions may be lost. To prevent this, they must be set again after the standby mode is canceled.

R/W	RS	DB7	DB6	DB5	DB4	DB3	DB2	DB1	DB0
0	0	0	0	0	0	1	AMP	SLP	STB

Figure 3 Power Control Instruction

Contrast Control 1/2

SW: Switches the bit configuration for the contrast control instruction.

CT4-CT0: When SW = 0, they control the LCD drive voltage (potential difference between V1 and GND) to adjust contrast. A 64-step adjustment is also possible by using the CT5 bit which are set in the entry mode register. For details, see the Contrast Adjuster section.

R/W	RS	DB7	DB6	DB5	DB4	DB3	DB2	DB1	DB0		
0	0	0	0	0	1	0	SW	CT4	CT3	(SW = 0)	
								BT1	BT0	(SW = 1)	
0	0	0	0	0	1	1		CT2	CT1	CT0	(SW = 0)
								BS2	BS1	BS0	(SW = 1)

Figure 4 Contrast-Control 1/2 Instruction

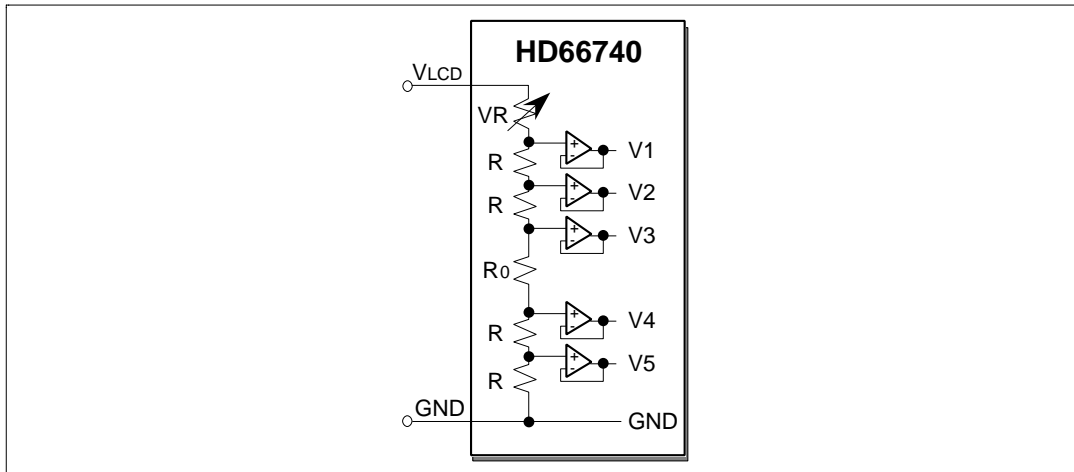

Figure 5 Contrast Adjuster

HD66740

Table 6 CT Bits and Variable Resistor Value of Contrast Adjuster

CT Set Value						Variable Resistor (VR)
CT5	CT4	CT3	CT2	CT1	CT0	
0	0	0	0	0	0	3.20 x R
0	0	0	0	0	1	3.15 x R
0	0	0	0	1	0	3.10 x R
0	0	0	0	1	1	3.05 x R
0	0	0	1	0	0	3.00 x R
			•			•
			•			•
0	1	1	1	1	1	1.65 x R
1	0	0	0	0	0	1.60 x R
1	0	0	0	0	1	1.55 x R
1	0	0	0	1	0	1.50 x R
			•			•
			•			•
1	1	1	1	0	1	0.15 x R
1	1	1	1	1	0	0.10 x R
1	1	1	1	1	1	0.05 x R

BT1-0: When SW = 1, they switch the output of V5OUT between triple, quadruple, and five-times boost. The liquid crystal display drive voltage level can be selected according to its drive duty ratio and bias. A lower amplification of the booster consumes less current.

BS2-0: When SW = 1, they set the crystal display drive bias value within the range of 1/4 to 1/10 bias. The liquid crystal display drive bias value can be selected according to its drive duty ratio and voltage. For details, see the Liquid Crystal Display Drive Bias Selector section.

Table 7 BT Bits and Output Level

BT1	BT0	V5OUT Output Level
0	0	Triple boost
0	1	Quadruple boost
1	0	Five-times boost
1	1	Setting inhibited

Table 8 BS Bits and LCD Drive Bias Value

BS2	BS1	BS0	Liquid Crystal Display Drive Bias Value
0	0	0	1/10 bias drive
0	0	1	1/9.5 bias drive
0	1	0	1/9 bias drive
0	1	1	1/8 bias drive
1	0	0	1/7 bias drive
1	0	1	1/6 bias drive
1	1	0	1/5 bias drive
1	1	1	1/4 bias drive

HD66740

Entry Mode

REV: Displays all graphics display sections with black-and-white reversal when SW = 0 and REV = 1. For details, see the Reversed Display Function section.

I/D: When SW = 0, increments (I/D = 1) or decrements (I/D = 0) the CGRAM address by 1 when a data is written into or read from the CGRAM.

CT5: Sets the most significant bit (CT5) for contrast adjustment when SW = 1. A 64-step adjustment is also possible by using the CT4–CT0 bits which are set in the contrast-control 1/2 instruction.

RDM: When SW = 1 and RDM = 0, the RDM increments or decrements the address counter value according to the I/D bit setting after reading the data from the CGRAM. When RDM = 1, the address counter value is not updated after the data has been read from the CGRAM. The address counter value is used when the RAM data is read, modified, and written. Since the first read data is invalid, the read must be continuously done twice. After writing to the RAM, the address counter value must be updated.

R/W	RS	DB7	DB6	DB5	DB4	DB3	DB2	DB1	DB0	
0	0	0	0	1	0	0	REV	I/D	1	(SW = 0)
							CT5	RDM	0	(SW = 1)

Figure 6 Entry Mode Set Instruction

Display On/Off Control

D: Display is on when SW = 0 and D = 1 and off when D = 0. When off, the display data remains in the DDRAM or CGRAM, and can be displayed instantly by setting D = 1. When D is 0, the display is off with the SEG1 to SEG112 outputs and COM1 to COM80 outputs set to the GND level. Because of this, the HD66740 can control charging current for the LCD with AC driving.

DL10: When SW = 0, DL10 can be set. When DL10 = 1, the 10th line is displayed at double height.

DL9–DL7: When SW = 1, DL9–DL7 can be set. Double-height display is specified for any display line. When DL7 = 1, the seventh line is displayed at double height. Double-height display is used for the eighth line when DL8 = 1 and for the ninth line when DL9 = 1. For double-height display for the first to the sixth lines, control them by using DL1–DL6 bits in the display-line control instruction.

R/W	RS	DB7	DB6	DB5	DB4	DB3	DB2	DB1	DB0	
0	0	0	0	1	1	0	D	DL10	0	(SW = 0)
							DL9	DL8	DL7	(SW = 1)

Figure 7 Display On/Off Control Instruction

HD66740

Display Line Control

NL3-0: Set NL2–NL0 bits when SW = 0, and the NL3 bit when SW = 1 to specify the display lines. Display lines change the liquid crystal display drive duty ratio. CGRAM address mapping does not depend on the number of display lines.

R/W	RS	DB7	DB6	DB5	DB4	DB3	DB2	DB1	DB0	
0	0	0	0	1	1	1	NL2	NL1	NL0	(SW = 0)
							CN1	CN0	NL3	(SW = 1)

Figure 8 Display-line Control Instruction

Table 9 NL Bits and Display Lines

NL3	NL2	NL1	NL0	Graphics Display	LCD Drive Duty	Common Driver Used
0	0	0	0	112 x 8 dots	1/8 Duty	COM1–COM8
0	0	0	1	112 x 16 dots	1/16 Duty	COM1–COM16
0	0	1	0	112 x 24 dots	1/24 Duty	COM1–COM24
0	0	1	1	112 x 32 dots	1/32 Duty	COM1–COM32
0	1	0	0	112 x 40 dots	1/40 Duty	COM1–COM40
0	1	0	1	112 x 48 dots	1/48 Duty	COM1–COM48
0	1	1	0	112 x 56 dots	1/56 Duty	COM1–COM56
0	1	1	1	112 x 64 dots	1/64 Duty	COM1–COM64
1	0	0	0	112 x 72 dots	1/72 Duty	COM1–COM72
1	0	0	1	112 x 80 dots	1/80 Duty	COM1–COM80

CN1–CN0: Set CN1–CN0 bits when SW = 1. When CN1–0 = 01, the display position is shifted by 16 dots below and display starts from COM17. When the liquid crystal is driven at low duty in the system wait state, it can display partially at the center of the screen. For details, see the Partial-display-on Function section.

When CN1–CN0 = 10, the display position is shifted by 8 dots above and second-line display starts from COM1. The 8 dots of the first line are moved to the lowest edge of the display screen. The output position of the lowest edge depends on the drive duty setting. In vertical smooth scrolling, PS1–PS0 bits can selectively fixed-display only the first to the third lines. Combining these functions enables the fixed display of one line of the lowest edge. For details, see the Partial Smooth Scroll Display Function section.

Table 10 Common Driver Pin Function

Common Driver Pin	Common Driver Pin Function					
	CN 1-0 = 00 (Normal Output)		CN 1-0 = 01 (Center Output)		CN1-0 = 10 (Lowest-edge Output)	
	CMS = 0	CMS = 1	CMS = 0	CMS = 1	CMS = 0	CMS = 1
COM1/80	COM1	COM80	COM65	COM64	COM9	COM8
COM2/79	COM2	COM79	COM66	COM63	COM10	COM7
⋮	⋮	⋮	⋮	⋮	⋮	⋮
COM7/72	COM7	COM74	COM71	COM58	COM15	COM2
COM8/73	COM8	COM73	COM72	COM57	COM16	COM1
COM9/72	COM9	COM72	COM73	COM56	COM17	COM80
COM10/71	COM10	COM71	COM74	COM55	COM18	COM79
⋮	⋮	⋮	⋮	⋮	⋮	⋮
COM15/66	COM15	COM66	COM79	COM50	COM23	COM73
COM16/65	COM16	COM65	COM80	COM49	COM24	COM72
COM17/64	COM17	COM64	COM1	COM48	COM25	COM71
COM18/63	COM18	COM63	COM2	COM47	COM26	⋮
⋮	⋮	⋮	⋮	⋮	⋮	COM66
COM24/57	COM24	COM57	COM8	COM41	COM32	COM65
COM25/56	COM25	COM56	COM9	COM40	COM33	COM64
⋮	⋮	⋮	⋮	⋮	⋮	⋮
COM32/49	COM32	COM49	COM16	COM33	COM40	COM57
COM33/48	COM33	COM48	COM17	COM32	COM41	COM56
⋮	⋮	⋮	⋮	⋮	⋮	⋮
COM40/41	COM40	COM41	COM24	COM25	COM48	COM49
COM41/40	COM41	COM40	COM25	COM24	COM49	COM48
⋮	⋮	⋮	⋮	⋮	⋮	⋮
COM48/33	COM48	COM33	COM32	COM17	COM56	COM41
COM49/32	COM49	COM32	COM33	COM16	COM57	COM40
⋮	⋮	⋮	⋮	⋮	⋮	⋮
COM56/25	COM56	COM25	COM40	COM9	COM64	COM33
COM57/24	COM57	COM24	COM41	COM8	COM65	COM32
⋮	⋮	⋮	⋮	⋮	⋮	⋮
COM64/17	COM64	COM17	COM48	COM1	COM72	COM25
COM65/16	COM65	COM16	COM49	COM80	COM73	COM24
⋮	⋮	⋮	⋮	⋮	⋮	⋮
COM72/9	COM72	COM9	COM56	COM73	COM80	COM17
COM73/8	COM73	COM8	COM57	COM72	COM1	COM16
⋮	⋮	⋮	⋮	⋮	COM2	COM15
COM79/2	COM79	COM2	COM63	COM66	⋮	⋮
COM80/1	COM80	COM1	COM64	COM65	COM8	COM9

Double-height Display Control

DL3-1: Can be specified when SW = 0. Specify the double-height display for any line. When DL1 = 1, the first line is displayed at double height. When DL2 = 1, the second line is displayed at double

HD66740

height. When DL3 = 1, the third line is displayed at double height. Double-height display of multiple lines is possible. For details, see the Double-height Display section.

DL6-4: Can be specified when SW = 1. Specify the double-height display for any line. When DL4 = 1, the fourth line is displayed at double height. When DL5 = 1, the fifth line is displayed at double height. When DL6 = 1, the sixth line is displayed at double height. For the seventh to 10th lines, control double-height display by using the DL7–DL10 bits in the display-line control instruction. For details, see the Double-height Display section.

R/W	RS	DB7	DB6	DB5	DB4	DB3	DB2	DB1	DB0	
0	0	0	1	0	0	0	DL3	DL2	DL1	(SW = 0)
							DL6	DL5	DL4	(SW = 1)

Figure 9 Double-height Display Control Instruction

Vertical Scroll Control 1/2

SN3-0: Set SN2 to SN0 bits when SW = 0. Set the SN3 bit when SW = 1. Specify the display start line output from COM1. Because the CGRAM is assigned a 10-line display area, the data is displayed sequentially from the first line to the 10th line then repeated from the first line again. In partial smooth scrolling, these bits specify the display start line for the next line of the fixed-display line. For details, see the Partial Smooth Scroll Display Function section.

SL2-0: Select the top raster-row to be displayed (display-start raster-row) in the display-start line specified by SN2 to SN0. Any raster-row from the first to eighth can be selected (table 12). This function is used to achieve vertical smooth scrolling together with SN2 to SN0. For details, see the Vertical Smooth Scroll section.

R/W	RS	DB7	DB6	DB5	DB4	DB3	DB2	DB1	DB0	
0	0	0	1	0	0	1	SN2	SN1	SN0	(SW = 0)
							<0>	<0>	SN3	(SW = 1)
0	0	0	1	0	1	0	SL2	SL1	SL0	(SW = 0)
							<0>	PS1	PS0	(SW = 1)

Figure 10 Vertical Scroll Control 1/2 Instruction

Table 11 SN Bits and Display-start Lines

SN3	SN2	SN1	SN0	Display-start Line
0	0	0	0	1st line
0	0	0	1	2nd line
0	0	1	0	3rd line
0	0	1	1	4th line
0	1	0	0	5th line
0	1	0	1	6th line
0	1	1	0	7th line
0	1	1	1	8th line
1	0	0	0	9th line
1	0	0	1	10th line

HD66740

Table 12 SL Bits and Display-start Raster-row

SL2	SL1	SL0	Display-start Raster-row
0	0	0	1st raster-row
0	0	1	2nd raster-row
0	1	0	3rd raster-row
0	1	1	4th raster-row
1	0	0	5th raster-row
1	0	1	6th raster-row
1	1	0	7th raster-row
1	1	1	8th raster-row

PS1–0: Specify PS1 to PS0 bits when SW = 1. When PS1–0 = 01, only the first line is fixed-displayed in vertical smooth scrolling, and the other display lines are smooth-scrolled. When PS1–0 = 10, the first and second lines are fixed-displayed. When PS1–0 = 11, the first to third lines are fixed-displayed. For details, see the Partial Smooth Scroll Display Function section.

LCD-Driving-Pattern Control

B/C: When SW=1 and B/C=0, a B-pattern waveform is generated and alternates in every frame for LCD drivin. When B/C=1, a C-pattern waveform is generated and alternates (n-raster-row reversed AC drive) in each raster-row specified by bits EOR and NW4–NW0 in the LCD-driving-waveform control register. For details, see the n-raster-row Reversed AC Drive section.

DCC: When SW=1 and DCC=0, a booster operates with the 64-divided clock of the operating frequency. When DCC=1, the booster operates with the 32-divided clock. When the booster operates with the 64-divided clock, current consumption in the booster is low, but boosting ability is weak.

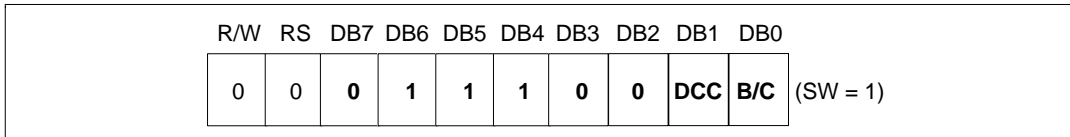

Figure 10a LCD-Driving-Waveform Control Instruction

LCD-Driving-Waveform Control

EOR: When the C-pattern waveform is set (B/C = 1) and SW = 1 and EOR = 1, the odd/even frame-select signals and the n-raster-row reversed signals are EORed for alternating drive. EOR is used when the LCD is not alternated by combining the set values of the LCD drive duty ratio and n raster-row. For details, see the n-raster-row Reversed AC Drive section.

NW4–0: Specify the number of raster-rows n that will alternate at the C-pattern waveform setting (B/C = 1). NW4–NW0 alternate in every set value + 1 raster-row, and the first to the 32nd raster-rows can be selected. When SW = 0, bits NW2, NW1, and NW0 can be set. When SW = 1, bits NW4 and NW3 can be set.

R/W	RS	DB7	DB6	DB5	DB4	DB3	DB2	DB1	DB0	
0	0	0	1	1	1	1	NW2	NW1	NW0	(SW = 0)
							EOR	NW4	NW3	(SW = 1)

Figure 11 LCD-Driving-Waveform Control Instruction

HD66740

RAM Address Set

AD10-0: Initially set RAM addresses to the address counter (AC). Once the RAM data is written, the AC is automatically updated according to the I/D bit. This allows consecutive accesses without resetting addresses. Once the RAM data is read, the AC is automatically updated according to the I/D bit when RDM = 0, and not updated when RDM = 1. Set RDM to 1 when read, modify, and write are done in every one-byte data. RAM address setting is not allowed in the sleep mode or standby mode.

R/W	RS	DB7	DB6	DB5	DB4	DB3	DB2	DB1	DB0
0	0	1	0	1	AD10	AD9	AD8	AD7	AD6
0	0	1	1	AD5	AD4	AD3	AD2	AD1	AD0

Figure 12 RAM Address Set Instruction

Table 13 AD Bits and CGRAM Settings

AD10-AD0	CGRAM Setting
"000"H-"06F"H	Bit map data for COM1 to COM8
"080"H-"0EF"H	Bit map data for COM9 to COM16
"100"H-"16F"H	Bit map data for COM17 to COM24
"180"H-"1EF"H	Bit map data for COM25 to COM32
"200"H-"26F"H	Bit map data for COM33 to COM40
"280"H-"2EF"H	Bit map data for COM41 to COM48
"300"H-"36F"H	Bit map data for COM49 to COM56
"380"H-"3EF"H	Bit map data for COM57 to COM64
"400"H-"46F"H	Bit map data for COM65 to COM72
"480"H-"4EF"H	Bit map data for COM73 to COM80

Write Data to RAM

WD7-0 : Write 8-bit data to the CGRAM. After a write, the address is automatically incremented or decremented by 1 according to the I/D bit setting. During the sleep and standby modes, the CGRAM cannot be accessed.

R/W	RS	DB7	DB6	DB5	DB4	DB3	DB2	DB1	DB0
0	1	WD7	WD6	WD5	WD4	WD3	WD2	WD1	WD0

Figure 13 Write Data to RAM Instruction

Read Data from RAM

RD7-0 : Read 8-bit data from the CGRAM. In the parallel bus interface mode, the first-byte data read will be invalid immediately after the RAM address set, and the consecutive second-byte data will be read normally. In the serial interface mode or I2C bus interface mode, two bytes will be invalid immediately after the start byte, and the consecutive third-byte data will be read normally. For details, see the Serial Data Transfer section.

After a RAM read, when RDM = 0, the address is automatically incremented or decremented by 1 according to the I/D bit. When RDM = 1, the address is not updated.

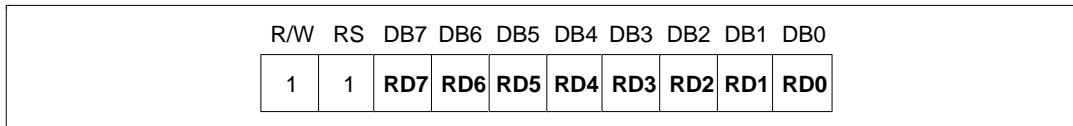

Figure 14 Read Data from RAM Instruction

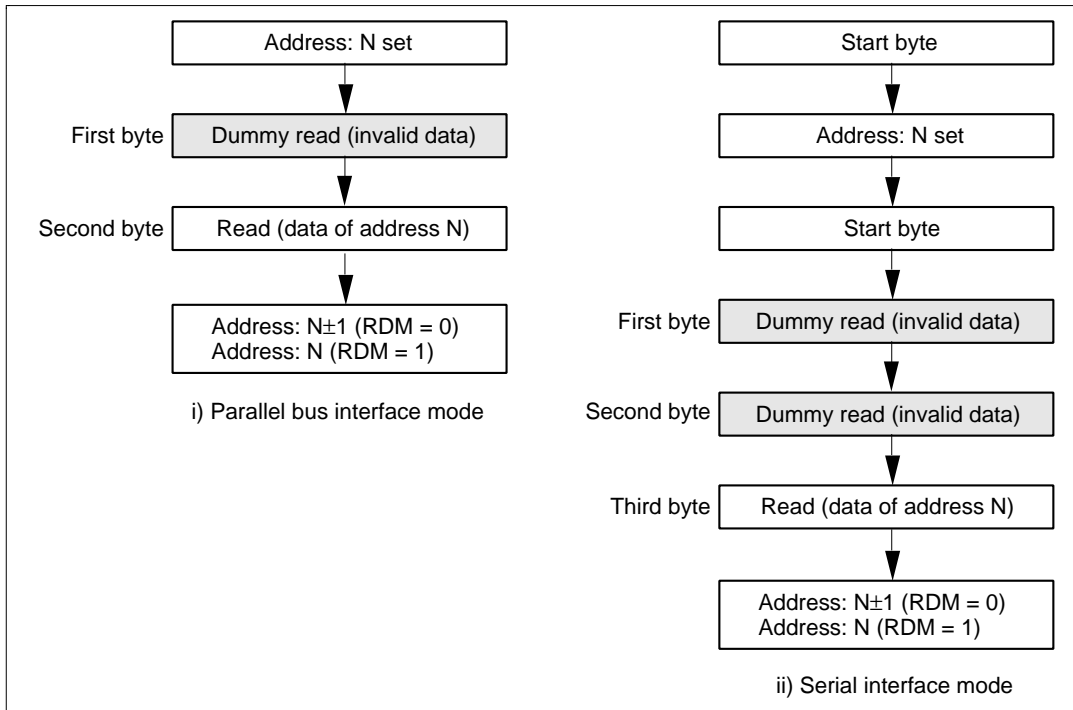

Figure 15 RAM Read Sequence

HD66740

Table 14 Instruction List

Register Name	Code										Description	Execution Cycle
	R/W	RS	DB7	DB6	DB5	DB4	DB3	DB2	DB1	DB0		
Start oscillation	0	0	0	0	0	0	0	0	1	1	Starts the oscillation standby mode.	—
Driver output control	0	0	0	0	0	0	0	1	CMS	SGS	Selects the common driver shift direction (CMS) and segment driver shift direction (SGS).	0
Power control	0	0	0	0	0	0	1	AMP	SLP	STB	Turns on LCD power supply (AMP), and sets the sleep mode (SLP) and standby mode (STB).	0
Contrast control 1	0	0	0	0	0	1	0	SW	CT4	CT3	Sets the register selection (SW) or upper contrast adjustment bits (CT4-3).	0
									BT1	BT0	Sets the register selection (SW) or boost level (BT1/0).	0
Contrast control 2	0	0	0	0	0	1	1	CT2	CT1	CT0	Sets the lower contrast adjustment bits (CT2-0).	0
									BS2	BS1	BS0	Sets the LCD bias value (BS2-0).
Entry mode set	0	0	0	0	1	0	0	REV	I/D	1	Sets the black-and-white reversal (REV) and address update direction after RAM access (I/D).	0
									CT5	RDM	0	Sets the higher contrast adjustment bit (CT5) and read modify write (RDM).

Table 14 Instruction List (cont)

Register Name	Code										Description	Execution Cycle
	R/W	RS	DB7	DB6	DB5	DB4	DB3	DB2	DB1	DB0		
Display on/off control	0	0	0	0	1	1	0	D	DL10	0	Sets display on (D) and double-height display line (DL10).	0
									DL9	DL8	DL7	Specifies double-height display lines (DL9–DL7).
Display line control	0	0	0	0	1	1	1	NL2	NL1	NL0	Sets the number of display lines (NL2-0).	0
								CN1	CN0	NL3	Specifies centering (CN1–0) or the number of display lines (NL3).	0
Double-height display control	0	0	0	1	0	0	0	DL3	DL2	DL1	Specifies double-height display lines (DL3-1).	0
								DL6	DL5	DL4	Specifies double-height display lines (DL6–4).	0
Vertical scroll control 1	0	0	0	1	0	0	1	SN2	SN1	SN0	Sets the display-start line (SN2-0).	0
								<0>	<0>	SN3	Sets the display-start line (SN3).	0
Vertical scroll control 2	0	0	0	1	0	1	0	SL2	SL1	SL0	Sets the display-start raster-row (SL2-0).	0
								<0>	PS1	PS0	Sets the partial scroll (PS1–0).	0

HD66740

Table 14 Instruction List (cont)

Register Name	Code											Description	Execution Cycle
	R/W	RS	DB7	DB6	DB5	DB4	DB3	DB2	DB1	DB0			
LCD-driving-pattern control	0	0	0	1	1	1	0	0	DCC	B/C		Selects the boosting cycle (DCC) or LCD drive AC waveform (B/C)	0
LCD-driving-waveform control	0	0	0	1	1	1	1	NW2	NW1	NW0		Sets the number of n-raster-rows (NW2–0) in C-pattern AC drive.	0
								EOR	NW4	NW3		Sets the EOR output (EOR) or the number of n-raster-rows (NW4–3) in C-pattern AC drive.	0
RAM address set (upper bits)	0	0	1	0	1			AD10–6	(upper bits)			Initially sets the upper addresses of the RAM to the address counter (AC).	0
RAM address set (lower bits)	0	0	1	1				AD5-0	(lower bits)			Initially sets the lower addresses of the RAM to the AC.	0
Write data to RAM	0	1						Write data				Writes data to CGRAM.	0
Read data from RAM	1	1						Read data				Reads data from CGRAM.	0

Notes: 1. The upper column of each register can be set when SW = 0. The lower column can be set when SW = 1.

Bit definition:

- CMS = 0: COM1/80 => COM1
- SGS = 0: SEG1/112 => SEG1
- AMP = 1: Operational amplifier and booster circuit on
- SLP = 1: Sleep mode
- STB = 1: Standby mode
- SW = 0: Upper register setting
- SW = 1: Lower register setting
- CT5-0: Contrast adjustment
- BT1-0: Boost level selection (00: Triple, 01: Quadruple, 10: Five-times)
- BS2-0: LCD drive bias selection
- REV = 0: Normal display
- REV = 1: Black-and-white reversed display of the graphics display
- ID = 1: Address increment
- ID = 0: Address decrement
- RDM = 1: Read, modify, and write mode (Not automatically update the address counter after reading)
- D = 1: Display on
- NL3-0: Display line setting (0000: 1/8 duty ratio, 0001: 1/16 duty ratio, 0010: 1/24 duty ratio, 0011: 1/32 duty ratio, 0100: 1/40 duty ratio, 0101: 1/48 duty ratio, 0110: 1/56 duty ratio, 0111: 1/64 duty ratio, 1000: 1/72 duty ratio, 1001: 1/80 duty ratio)
- DL1-10: Double-height line specifications (DL1: 1st line, DL2: 2nd line, DL3: 3rd line, DL4: 4th line, DL5: 5th line, DL6: 6th line, DL7: 7th line, DL8: 8th line, DL9: 9th line, DL10: 10th line)
- SN3-0: Display-start line (0000: 1st line, 0001: 2nd line, 0010: 3rd line, 0011: 4th line, 0100: 5th line, 0101: 6th line, 0110: 7th line, 0111: 8th line, 1000: 9th line, 1001: 10th line)
- SL2-0: Display-start raster-row specifications (000: 1st raster-row...111: 8th raster-row)
- CN1-0: Centering specifications (00: no centering, 01: 16-dot shift below, 10: 8-dot shift above)
- B/C = 0: B-pattern waveform drive
- B/C = 1: C-pattern waveform drive
- EOR = 1: EOR alternating drive at C-pattern waveform
- NW4-0: Reversed number of n raster-rows at C-pattern waveform drive (alternating with the set value + one raster-row)
- DCC = 0: Boosted at 1/64-divided clock
- DCC = 1: Boosted at 1/32-divided clock
- AD10-0: CGRAM address set (CGRAM: 000H-4EFH)

HD66740

Reset Function

The HD66740 is internally initialized by RESET input. The reset input must be held for at least 1 ms.

Instruction Set Initialization:

1. Start oscillation executed
2. Driver output control (SGS = 0, CMS = 0)
3. Power control (AMP = 0: LCD power off, SLP = 0: Sleep mode off, STB = 0: Standby mode off)
4. Three times boost (BT1/0 = 00), 1/10 bias drive (BS2/1/0 = 000), Weak contrast (CT5-0 = 00000)
5. Entry mode set (REV = 0: Normal display, I/D = 1: Increment by 1, RDM = 0: Automatically update after reading)
6. Display on/off control (D = 0: Display off, CEN = 0: Normal position)
7. Display line control (NL3/2/1/0 = 1001: 1/80 duty ratio)
8. Double-height display off (DL10-1 = 0000000000)
9. Vertical scroll control (SN3/2/1/0 = 0000: First line displayed at the top, SL2/1/0: First raster-row displayed at the top of the first line, PS1/0 = 00: Partial scroll off)
10. 1/64-divided clock boost (DCC = 0)
11. B-pattern waveform AC drive (B/C = 0, EOR = 0, NW4/3/2/1/0 = 00000)

RAM Data Initialization:

1. CGRAM

This is not automatically initialized by reset input but must be initialized by software while display is off (D = 0).

Output Pin Initialization:

1. LCD driver output pins (SEG/COM): Outputs GND level
2. Booster output pins (VLOUT): Outputs GND level
3. Oscillator output pin (OSC2): Outputs oscillation signal

Serial Data Transfer (Clock synchronized serial interface)

Setting the IM1 and IM2 pins (interface mode pins) to the GND level allows standard clock-synchronized serial data transfer, using the chip select line (CS*), serial data line (SDA), and serial transfer clock line (SCL). For a serial interface, the IM0/ID pin function uses an ID pin.

The HD66740 initiates serial data transfer by transferring the start byte at the falling edge of CS* input. It ends serial data transfer at the rising edge of CS* input.

The HD66740 is selected when the 6-bit chip address in the start byte transferred from the transmitting device matches the 6-bit device identification code assigned to the HD66740. The HD66740, when selected, receives the subsequent data string. The least significant bit of the identification code can be determined by the ID pin. The five upper bits must be 01110. Two different chip addresses must be assigned to a single HD66740 because the seventh bit of the start byte is used as a register select bit (RS): that is, when RS = 0, an instruction can be issued, and when RS = 1, data can be written to or read from RAM. Read or write is selected according to the eighth bit of the start byte (R/W bit) as shown in table 16.

After receiving the start byte, the HD66740 receives or transmits the subsequent data byte-by-byte. The data is transferred with the MSB first.

Two bytes of RAM read data after the start byte are invalid. The HD66740 starts to read correct RAM data from the third byte.

Table 15 Start Byte Format

Transfer Bit	S	1	2	3	4	5	6	7	8
Start byte format	Transfer start	Device ID code						RS	R/W
		0	1	1	1	0	ID		

Note: ID bit is selected by the IM0/ID pin.

Table 16 RS and R/W Bit Function

RS	R/W	Function
0	0	Writes instruction
0	1	-
1	0	Writes RAM data
1	1	Reads RAM data

HD66740

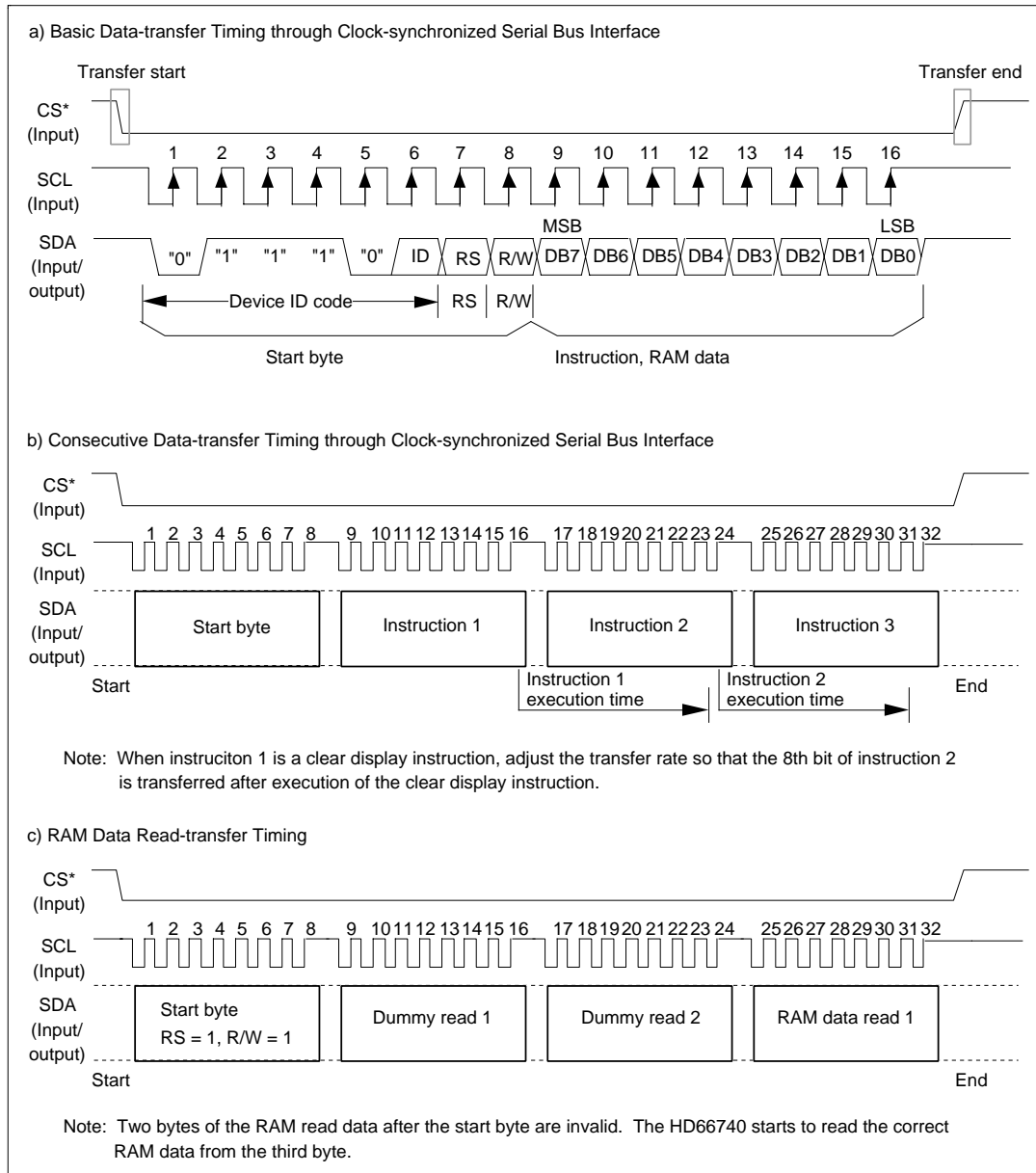

Figure 16 Clock-synchronized Serial Interface Timing Sequence

Serial Data Transfer (I2C bus interface)

Setting the IM2=Vcc and IM1=GND level allows I2C bus interface, using the serial data line (SDA) and serial transfer clock line (SCL). For the I2C bus interface, the IM0/ID pin function uses an ID pin.

The HD66740W is initiated serial data transfer by transferring the first byte when a high SCL level at the falling edge of the SDA input is sampled; it ends serial data transfer when a high SCL level at the rising edge of the SDA input is sampled.

Table 16-a illustrates the start byte of I2C bus interface data and Figure 16-a and 16-b show the I2C bus interface timing sequence.

The HD66740W is selected when the higher 6-bit slave address in the first byte transferred from the master device match the 6-bits device identification code assigned to the HD66740W. The HD66740W, when selected, receive the subsequent data string. The lower 1-bit of the device identification code can be determined by the ID pin; select an appropriate code that is not assigned to any other slave device. The upper five bits are fixed to 01110. One slave address is assigned to a single HD66740W.

The ninth bit of the first byte is a receive-data acknowledge bit (ACK). When the received slave address matches the device ID code, HD66740W pulls down the ACK bit to a low level. Therefore, the ACK output buffer is an open-drain structure, only allowing low-level output. However, the ACK bit is undermined immediately after power-on; make sure to initialize the LSI using the RESET* input.

After identifying the address in the first byte, the HD66740W receives the subsequent data as an HD66740W instruction or as RAM data. Having received 8-bit data normally, HD66740W pulls down the ninth bit (ACK) to a low level. The instruction or RAM data is 8-bits data format.

Two bytes of RAM read data after the start byte are invalid. The HD66740W start to read correct RAM data from third byte.

Table 16-a Start Byte Format

Transfer Bit	S	1	2	3	4	5	6	7	8	9	
Start byte format	Transfer start	Device ID code					RS	R/W	ACK		
		0	1	1	1	0	ID				

Note: ID bit is selected by the IM0/ID pin.

Table 16-b RS and R/W bit function

RS	R/W	Function
0	0	Writes instruction
0	1	-
1	0	Writes RAM data
1	1	Reads RAM data

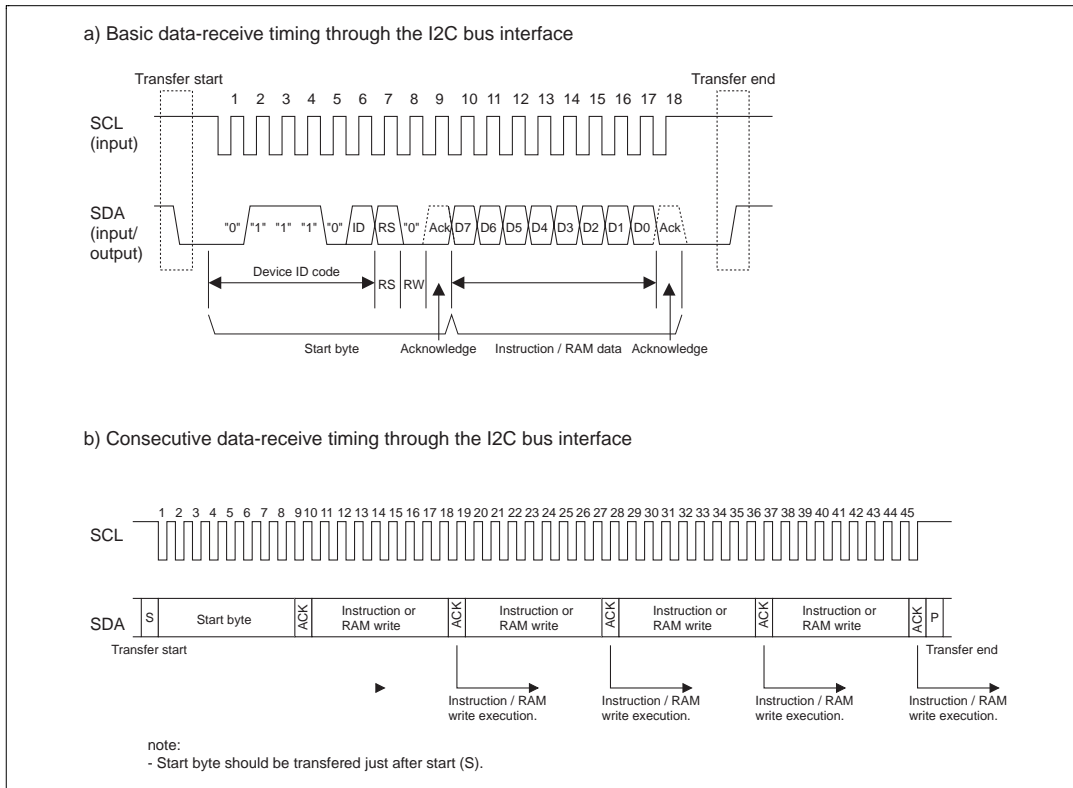

Figure 16-a I2C bus interface data-receive sequence

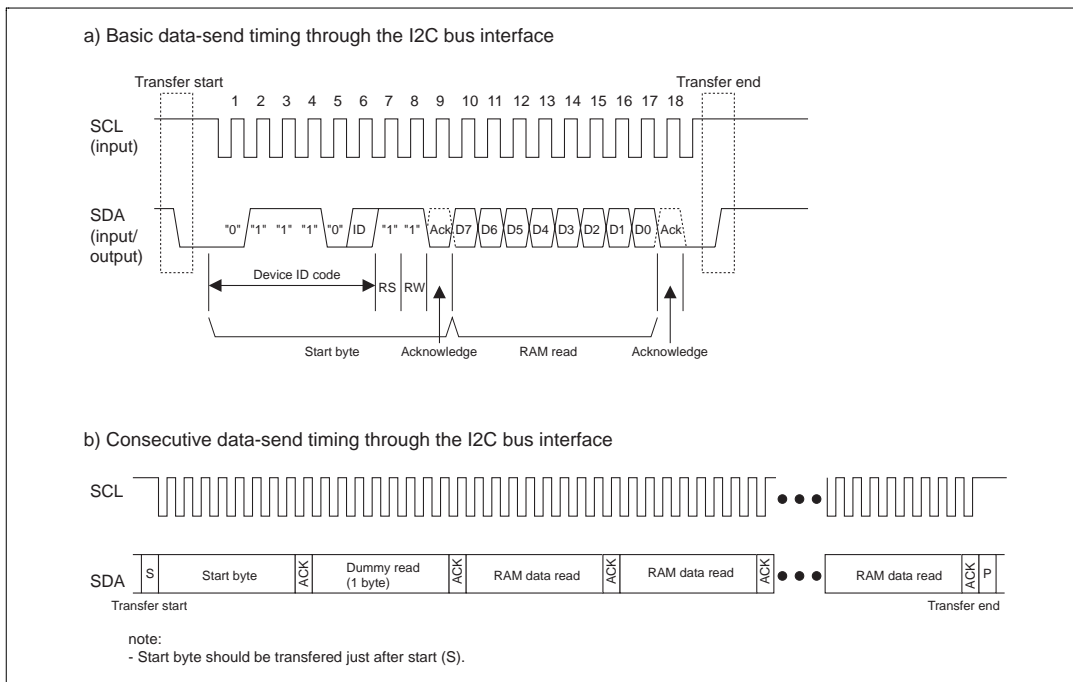

Figure 16-b I2C bus interface data-send sequence

Parallel Data Transfer

8-bit Bus Interface

Setting the IM2/1/0 (interface mode) to the GND/V_{cc}/GND level allows E-clock-synchronized 8-bit parallel data transfer. Setting the IM2/1/0 (interface mode) to the V_{cc}/V_{cc}/GND level allows 80-system 8-bit parallel data transfer. When the number of buses or the mounting area is limited, use a 4-bit bus interface or serial data transfer.

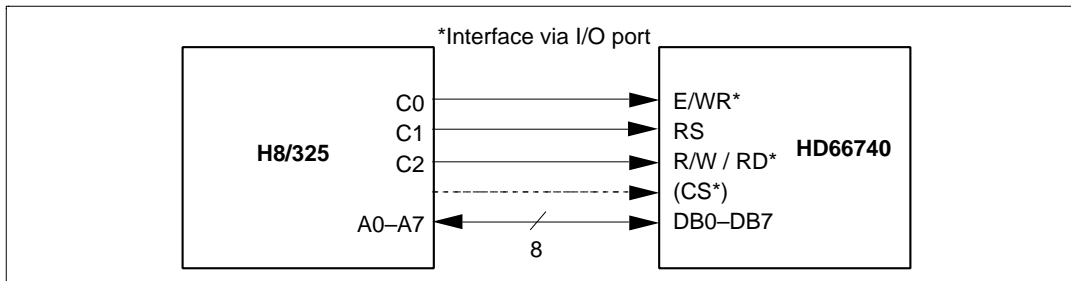

Figure 17 Interface to 8-bit Microcomputer

4-bit Bus Interface

Setting the IM2/1/0 (interface mode) to the GND/V_{cc}/V_{cc} level allows E-clock-synchronized 4-bit parallel data transfer using pins DB7-DB4. Setting the IM2/1/0 (interface mode) to the V_{cc}/V_{cc}/V_{cc} level allows 80-system 4-bit parallel data transfer. The 8-bit instructions and RAM data are divided into four upper/lower bits and the transfer starts from the upper four bits.

Note: Transfer synchronization function for a 4-bit bus interface

The HD66740 supports the transfer synchronization function which resets the upper/lower counter to count upper/lower 4-bit data transfer in the 4-bit bus interface. Noise causing transfer mismatch between the four upper and lower bits can be corrected by a reset triggered by consecutively writing a 0000 instruction four times. The next transfer starts from the upper four bits. Executing synchronization function periodically can recover any runaway in the display system.

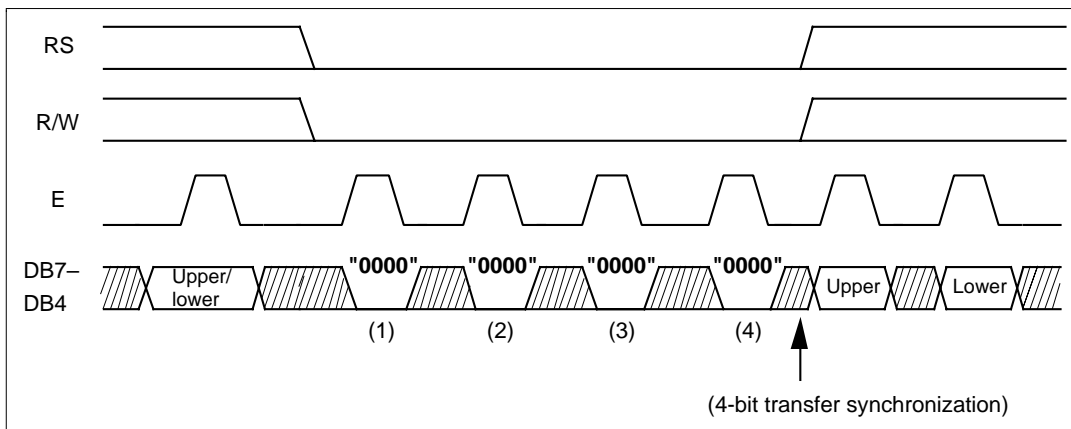

Figure 18 4-bit Transfer Synchronization

HD66740

Oscillation Circuit

The HD66740 can either be supplied with operating pulses externally (external clock mode) or oscillate using an internal R-C oscillator with an external oscillator-resistor (external resistor oscillation mode). Note that in R-C oscillation, the oscillation frequency is changed according to the internal capacitance value, the external resistance value, or operating power-supply voltage. Insert the dumping resistance of about 1.5kΩ to prevent malfunctions caused by over-shoot or under-shoot noise in the external clock mode.

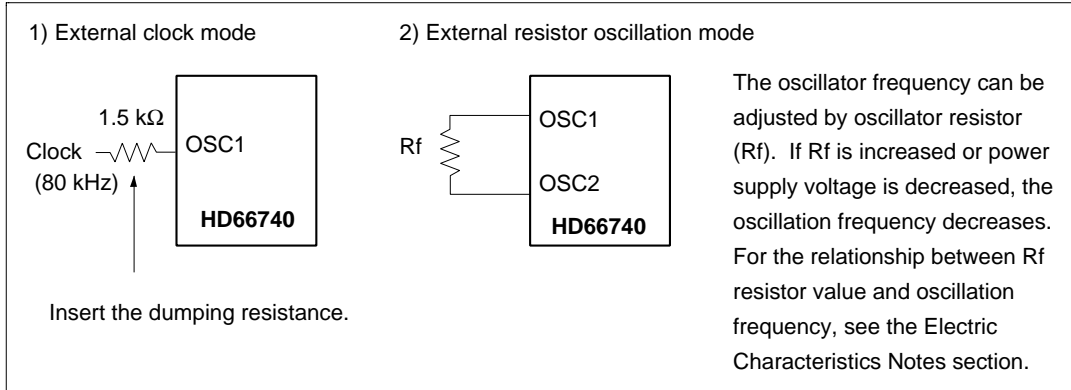

Figure 19 Oscillation Circuits

Table 17 Relationship between Drive Duty Ratio and Frame Frequency (fosc = 75 kHz)

	Display mode									
	1-line Dis- play	2-line Dis- play	3-line Dis- play	4-line Dis- play	5-line Dis- play	6-line Dis- play	7-line Dis- play	8-line Dis- play	9-line Dis- play	10-line Dis- play
	Set value for NL3-0									
LCD Drive	0000	0001	0010	0011	0100	0101	0110	0111	1000	1001
Multiplexing duty ratio	1/8	1/16	1/24	1/32	1/40	1/48	1/56	1/64	1/72	1/80
Drive bias (recommended value)	1/4	1/5	1/6	1/6	1/7	1/8	1/8	1/9	1/9.5	1/10
Frame frequency	73 Hz	73 Hz	73 Hz	73 Hz	72 Hz	74 Hz	74 Hz	73 Hz	65 Hz	59 Hz
One-frame frequency	1,024	1,024	1,032	1,024	1,040	1,008	1,008	1,024	1,152	1,280

Note: If the frame frequency is low and the display flickers, increase the oscillation frequency (fosc). Particularly in the 9-line display and 10-line display modes, note that the frame frequency is lowered.

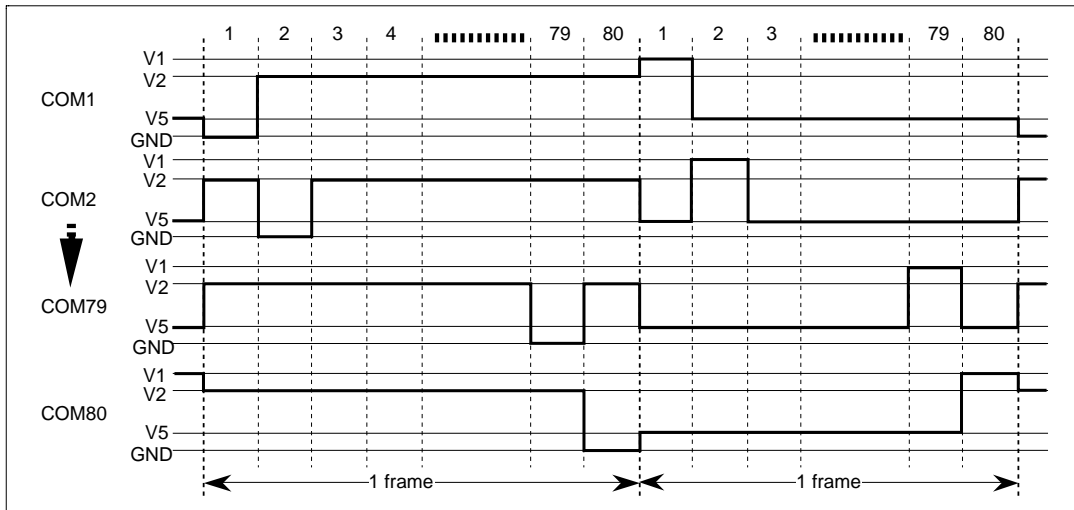

Figure 20 LCD Drive Output Waveform (B-pattern AC Drive with 1/80 Multiplexing Duty Ratio)

n-raster-row Reversed AC Drive

The HD66740 supports not only the LCD reversed AC drive in a one-frame unit (B-pattern waveform) but also the n-raster-row reversed AC drive which alternates in an n-raster-row unit from one to 32 raster-rows (C-pattern waveform). When a problem affecting display quality occurs, such as crosstalk at high-duty driving of more than five lines (1/40 duty), the n-raster-row reversed AC drive (C-pattern waveform) can improve the quality. Determine the number of raster-rows n (NW bit set value + 1) for alternating after confirmation of the display quality with the actual LCD panel. However, if the number of AC raster-rows is reduced, the LCD alternating frequency becomes high. Because of this, the charge or discharge current is increased in the LCD cells.

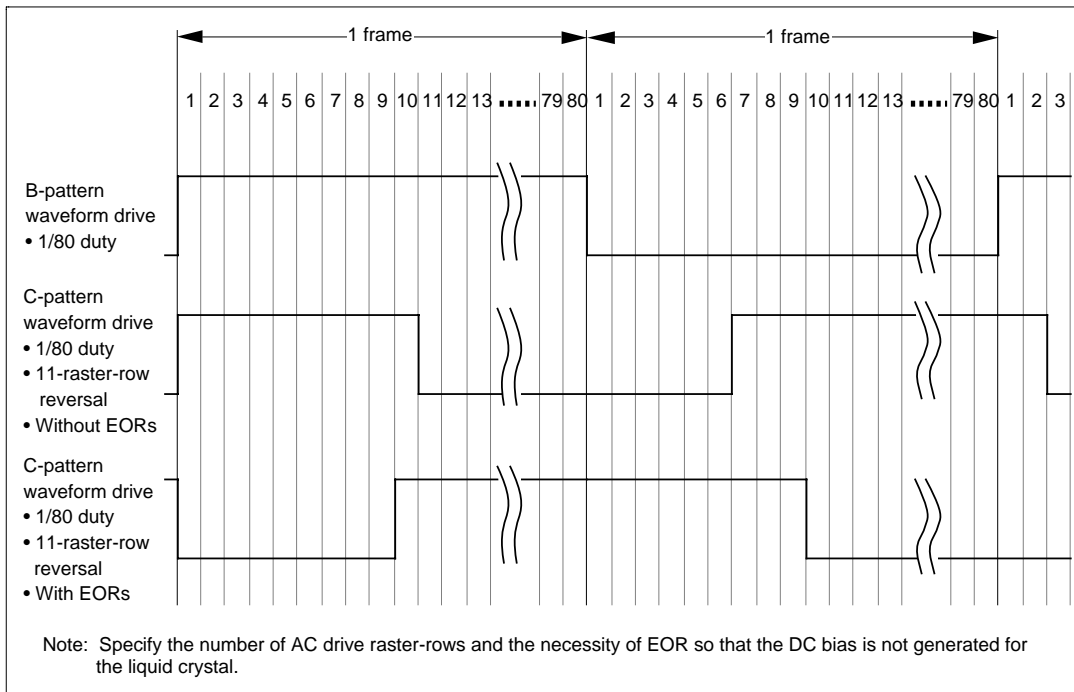

Figure 21 Example of an AC Signal under n-raster-row Reversed AC Drive

Liquid Crystal Display Voltage Generator

When External Power Supply and Internal Operational Amplifiers are Used

To supply LCD drive voltage directly from the external power supply without using the internal booster, circuits should be connected as shown in figure 22. Here, contrast can be adjusted by software through the CT bits of the contrast adjustment register.

The HD66740 incorporates a voltage-follower operational amplifier for each V1 to V5 to reduce current flowing through the internal bleeder-resistors, which generate different levels of liquid-crystal drive voltages. Thus, potential differences between V_{LCD} and V1 and between V5 and GND must be 0.4 V or higher. Note that the OPOFF pin must be grounded when using the operational amplifiers. Place a capacitor of about 0.1 μF to 0.5 μF between each internal operational amplifier V1OUT to V5OUT output and GND and stabilize the output level of the operational amplifier.

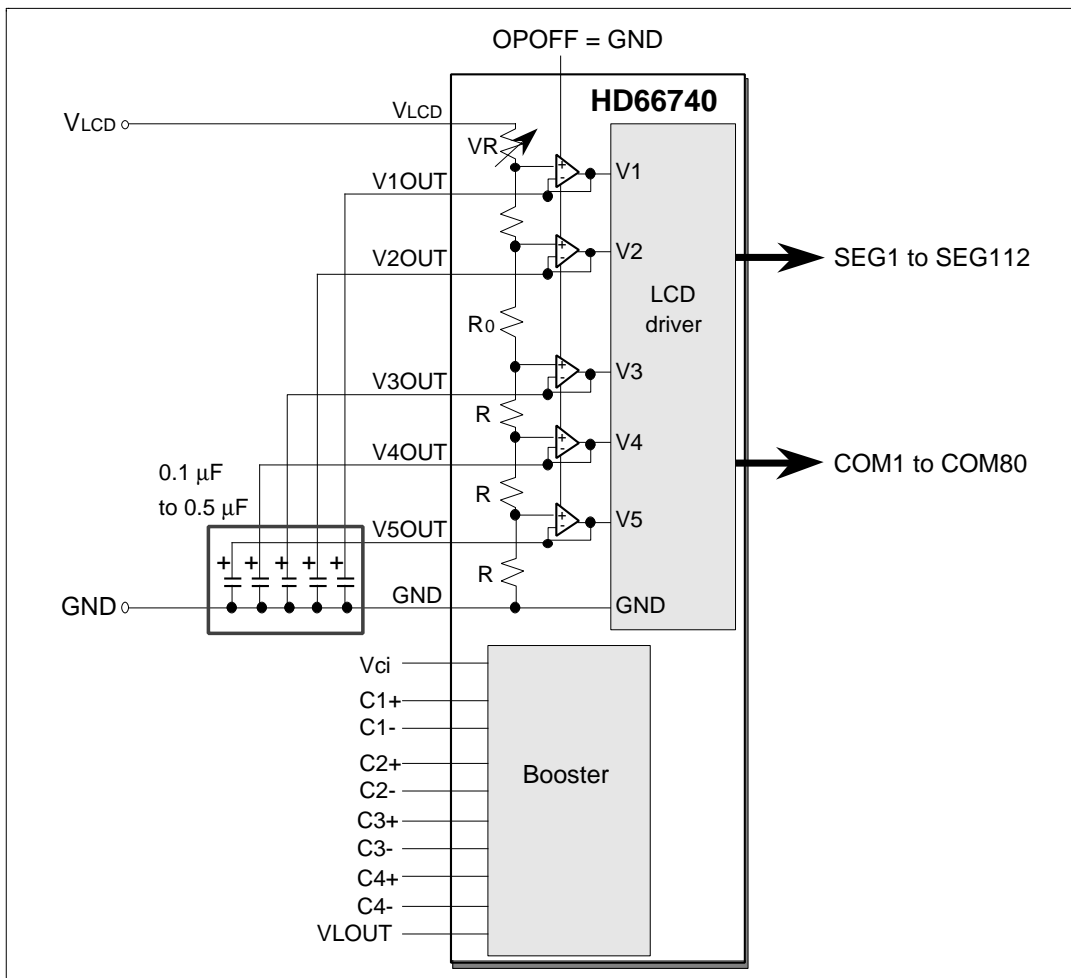

Figure 22 External Power Supply Circuit for LCD Drive Voltage Generation

HD66740

When an Internal Booster and Internal Operational Amplifiers are Used

To supply LCD drive voltage using the internal booster, circuits should be connected as shown in figure 23. Here, contrast can be adjusted through the CT bits of the contrast control instruction. Temperature can be compensated either through the CT bits or by controlling the reference voltage for the booster (Vci pin) using a thermistor.

Note that Vci is both a reference voltage and power supply for the booster. The reference voltage must therefore be adjusted using an emitter-follower or a similar element so that sufficient current can be supplied. In this case, Vci must be equal to or smaller than the V_{CC} level.

The HD66740 incorporates a voltage-follower operational amplifier for each of V1 to V5 to reduce current flowing through the internal bleeder-resistors, which generate different liquid-crystal drive voltages. Thus, the potential differences between V_{LCD} and V1 and between V5 and GND must be 0.4 V or higher.

Note that the OPOFF pin must be grounded when using the operational amplifiers. Place a capacitor of about 0.1 μF to 0.5 μF between each internal operational amplifier V1OUT to V5OUT output and GND and stabilize the output level of the operational amplifier.

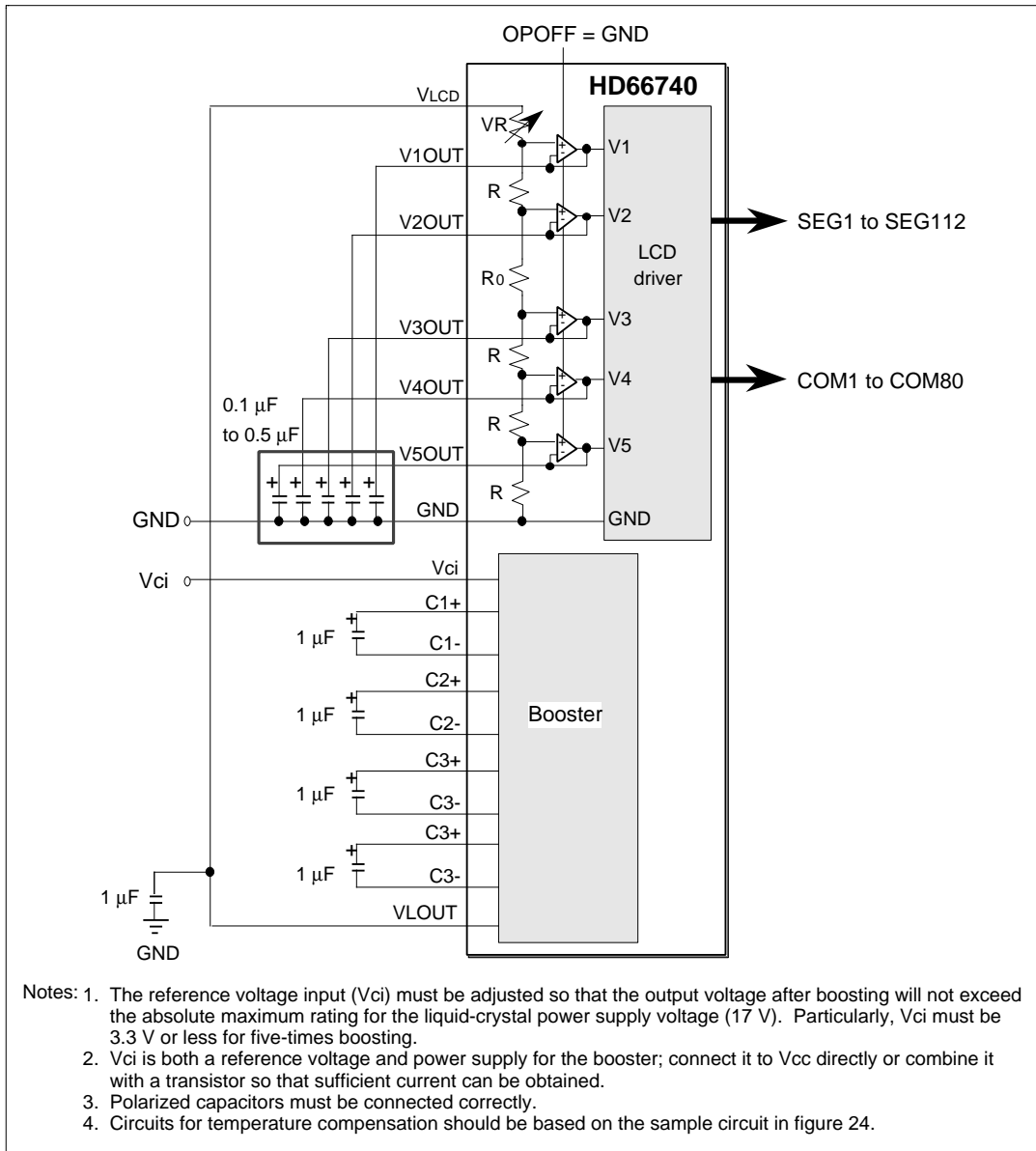

Figure 23 Internal Booster for LCD Drive Voltage Generation

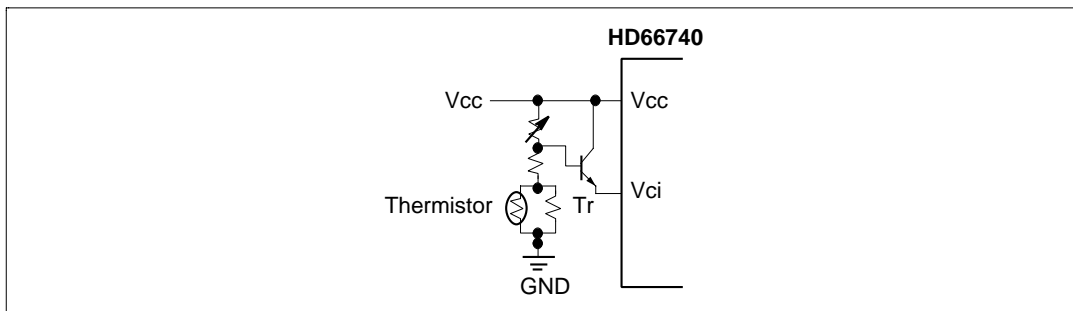

Figure 24 Temperature Compensation Circuit

HD66740

Notes on Using Internal Operational Amplifier

The HD66740 has a low-current-consumption-type operational amplifier. When a low-voltage supply is used, particularly at low temperatures near -20°C , the current in the operational amplifier is reduced. Therefore, depending on the specifications or display pattern of the LCD panel used, screen quality may be poor or the LCD panel may not operate at all.

For the operational specifications of the LCD panel, one must consider the drive condition (setting of the VTEST pin) or the peripheral circuits of the LCD panel in conjunction with the power-supply voltage.

Pin condition for HD66740 (setting VTEST pin):

1. When the power-supply voltage is $V_{cc} \geq 2.5\text{ V}$ (i.e., the current in the operational amplifier is sufficient), leave the VTEST pin open (disconnected).
2. When the power-supply voltage is $V_{cc} < 2.5\text{ V}$ (i.e., the current is reduced in the operational amplifier at low temperature), 1.2 to 1.3 V should be input to the VTEST pin.

The following table and figure correspond to inputs of 1.2 to 1.3 V to the VTEST pin. When higher LCD drive current is required due to the characteristics of the LCD panel, check the screen quality and current consumption, adjust the resistance values (R1 and R2), and increase the VTEST pin voltage. (This is also valid when $V_{cc} \geq 2.5\text{ V}$.)

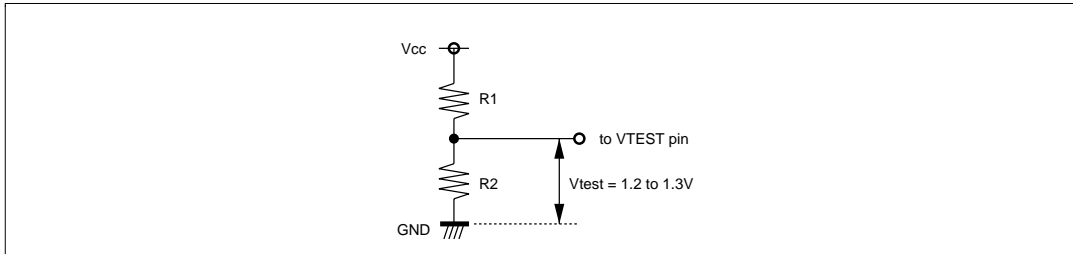

Figure 24-a Circuit to for Generating VTEST Pin Voltage

Table 17-a Settings to Generate VTEST Pin Voltage

Vcc	R1	R2	Vtest (VTEST Pin Voltage)
2.4 V	270 k Ω	330 k Ω	1.23 V
2.0 V	220 k Ω	360 k Ω	1.22 V
1.8 V	180 k Ω	390 k Ω	1.22 V

Countermeasures for Screen Quality when Using On-chip Operational Amplifier

The HD66740 is an on-chip LCD driver that has an LCD power supply for high duty. Screen quality is affected by the load current of the high-duty LCD panel used. When the bias (1/10 bias, 1/9.5 bias, 1/9 bias, etc.) is high and the displayed pattern is completely or almost completely white, the white sections may appear dark.

If this happens, execute the following countermeasures to improve screen quality.

- (1) After the change in the V4OUT/V3OUT level is verified, insert about 1 MΩ between V4OUT and GND or VLCD and V3OUT and then adjust the screen quality (see the following figures). By inserting resistance, the current consumption increases as much as the boosting factor of the resistance current. Adjust the resistance after checking the screen quality and the increase in current consumption.
- (2) Decrease the drive bias and use the new bias level after verifying that the potential differences between V4OUT and GND or VLCD and V3OUT are sufficient.

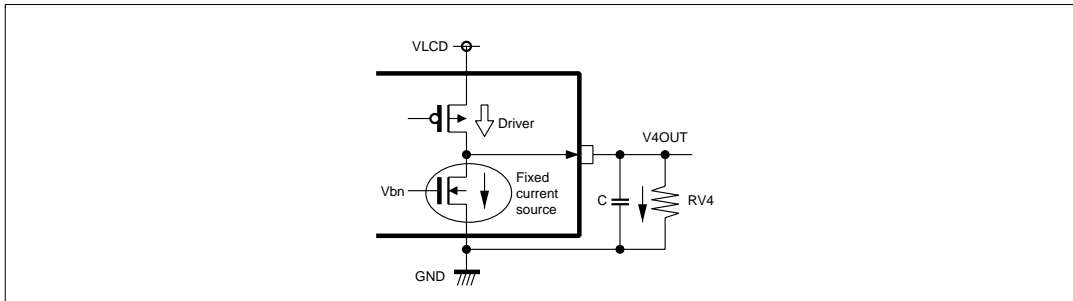

Figure 24-b Countermeasure for V4OUT Output

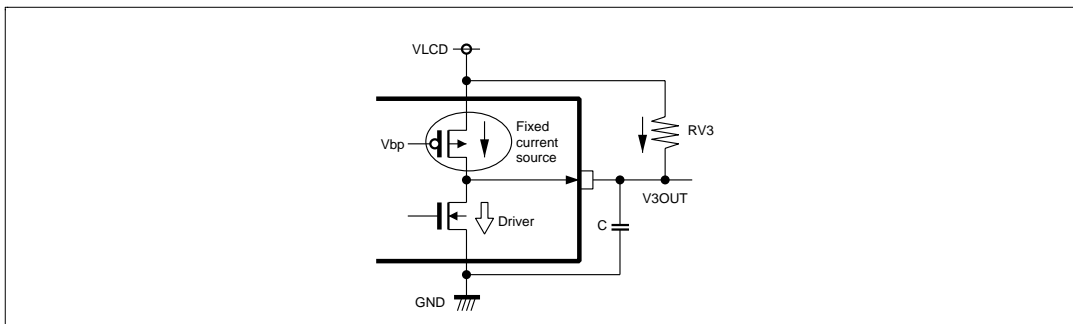

Figure 24-c Countermeasure for V3OUT Output

Note: The actual LCD drive voltage-VLCD used must not exceed 15.0 V, and the absolute rating must not exceed 16.0 V.

HD66740

Switching the Boosting Multiplying Factor

Instruction bits (BT1/0 bits) can optionally select the boosting multiplying factor of the internal booster. According to the display status, power consumption can be reduced by changing the LCD drive duty and the LCD drive bias, and by controlling the boosting multiplying factor for the minimum requirements. For details, see the Partial-display-on Function section.

Due to the maximum boosting multiplying factor, the following external capacitor needs to be connected. For example, when the maximum boosting is quadrupled, the capacitors between C4+ and C4- for five-times boosting are not needed, so these pins must be open.

Table 18 VLOUT Output Status

BT1	BT0	VLOUT Output Status
0	0	Triple boosting output
0	1	Quadruple boosting output
1	0	Five-times boosting output
1	1	Setting inhibited

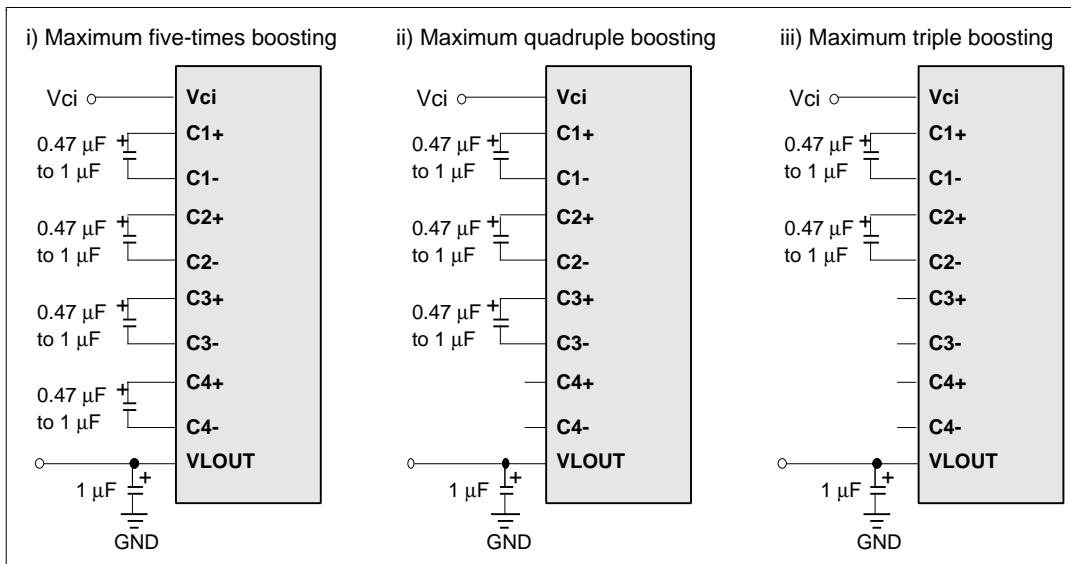

Figure 25 Booster Output Multiplying Factor Switching

Example of Power-supply Voltage Generator for More Than Five-times Boosting Output

The HD66740 incorporates the booster for up to five-times boosting. However, the LCD drive voltage (VLCD) will not be enough for five-times boosting from Vcc when the power-supply voltage of Vcc is low or when the LCD drive voltage is high for the high-contrast LCD display. In this case, the reference voltage (Vci) for boosting can be set higher than the power-supply voltage of Vcc.

Set the Vci input voltage for the booster to 3.6 V or less within the range of Vcc + 1.0 V. Control the Vci voltage so that the boosting output voltage (VLOUT) should be less than the absolute maximum ratings (17 V).

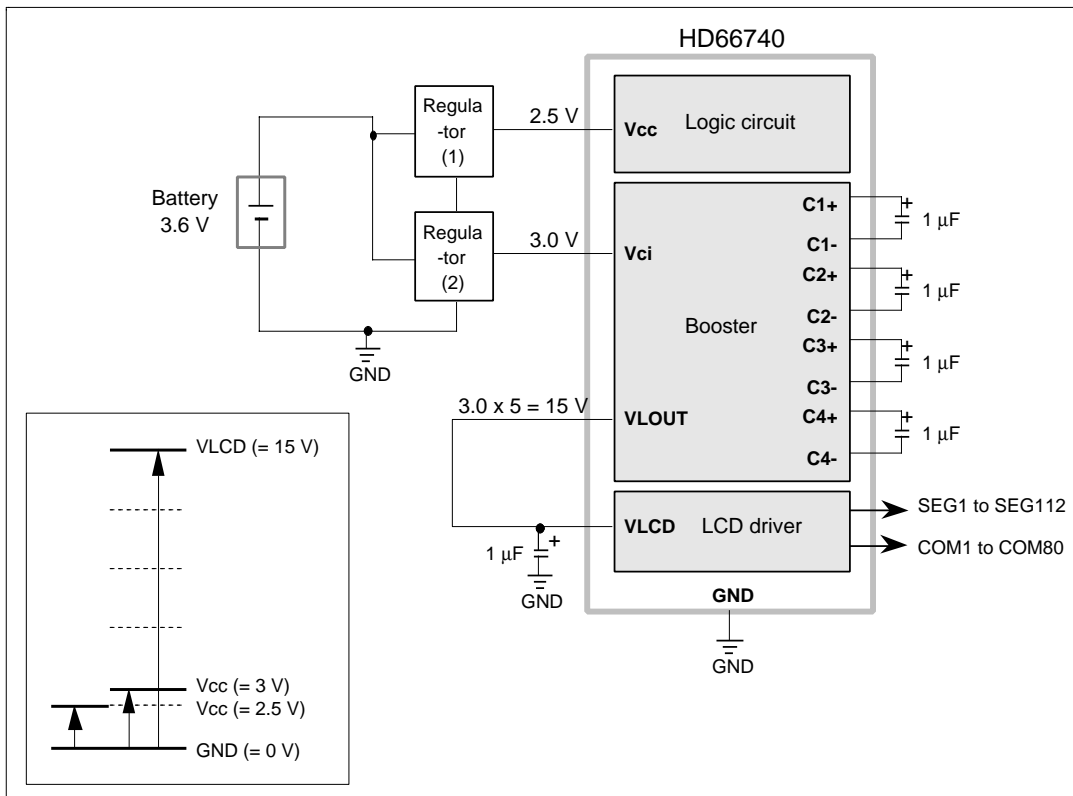

Figure 26 Usage Example of Booster at Vci > Vcc

HD66740

Contrast Adjuster

Software can adjust 64-step contrast for an LCD by varying the liquid-crystal drive voltage (potential difference between V_{LCD} and $V1$) through the CT bits of the contrast adjustment register (electron volume function). The value of a variable resistor between V_{LCD} and $V1$ (VR) can be precisely adjusted in a $0.05 \times R$ unit within a range from $0.05 \times R$ through $3.20 \times R$, where R is a reference resistance obtained by dividing the total resistance.

The HD66740 incorporates a voltage-follower operational amplifier for each of $V1$ to $V5$ to reduce current flowing through the internal bleeder resistors, which generate different liquid-crystal drive voltages. Thus, CT5-0 bits must be adjusted so that the potential differences between V_{LCD} and $V1$ and between $V5$ and GND are 0.4 V or higher when liquid-crystal drives, particularly when the VR is small.

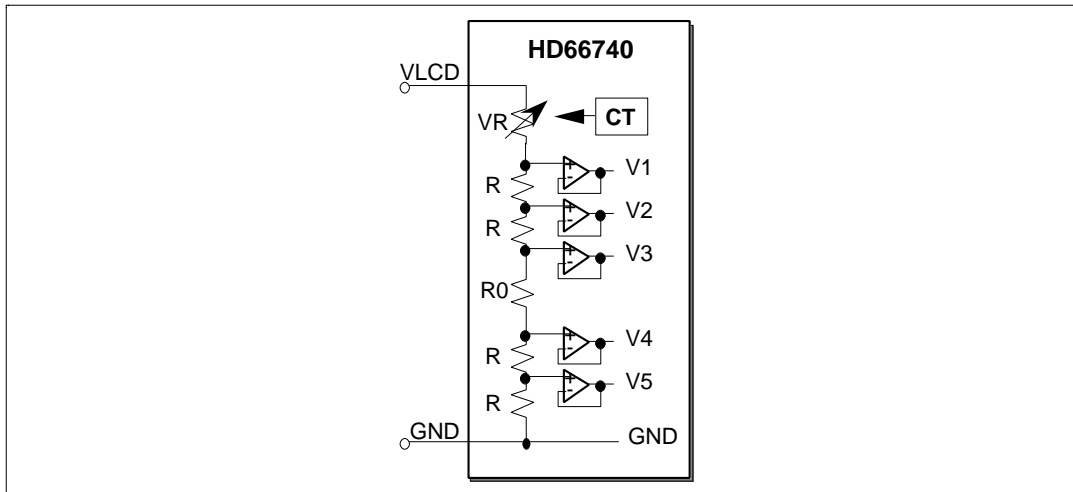

Figure 27 Contrast Adjuster

Table 19 Contrast Adjustment Bits (CT) and Variable Resistor Values

CT Set Value						Variable Resistor Value (VR)	Potential Difference between V1 and GND	Display Color		
CT5	CT4	CT3	CT2	CT1	CT0					
0	0	0	0	0	0	3.20 x R				
0	0	0	0	0	1	3.15 x R				
0	0	0	0	1	0	3.10 x R				
0	0	0	0	1	1	3.05 x R				
0	0	0	1	0	0	3.00 x R				
0	0	0	1	0	1	2.95 x R				
0	0	0	1	1	0	2.90 x R				
0	0	0	1	1	1	2.85 x R				
0	0	1	0	0	0	2.80 x R				
0	0	1	0	0	1	2.75 x R				
0	0	1	0	1	0	2.70 x R				
0	0	1	0	1	1	2.65 x R				
0	0	1	1	0	0	2.60 x R				
⋮						⋮				
0	1	1	1	1	1	1.65 x R				
1	0	0	0	0	0	1.60 x R				
1	0	0	0	0	1	1.55 x R				
1	0	0	0	1	0	1.50 x R				
1	0	0	0	1	1	1.45 x R				
1	0	0	1	0	0	1.40 x R				
1	0	0	1	0	1	1.35 x R				
1	0	0	1	1	0	1.30 x R				
1	0	0	1	1	1	1.25 x R				
1	0	1	0	0	0	1.20 x R				
1	1	1	0	0	1	1.15 x R				
⋮						⋮				
1	1	1	1	0	0	0.20 x R				
1	1	1	1	0	1	0.15 x R				
1	1	1	1	1	0	0.10 x R				
1	1	1	1	1	1	0.05 x R				

HD66740

Table 20 Contrast Adjustment per Bias Drive Voltage

Bias	LCD drive voltage: VDR	Contrast adjustment range
1/10 bias drive	$\frac{10 \times R}{10 \times R + VR} \times (VLCD - GND)$	<ul style="list-style-type: none"> - LCD drive voltage adjustment range : $0.757 \times (VLCD-GND) \leq VDR \leq 0.995 \times (VLCD-GND)$ - Limit of potential difference between V5 and GND : $\frac{R}{10 \times R + VR} \times (VLCD-GND) \geq 0.4 [V]$ - Limit if potential difference between VLCD and V1 : $\frac{VR}{10 \times R + VR} \times (VLCD-GND) \geq 0.4 [V]$
1/9.5 bias drive	$\frac{9.5 \times R}{9.5 \times R + VR} \times (VLCD - GND)$	<ul style="list-style-type: none"> - LCD drive voltage adjustment range : $0.748 \times (VLCD-GND) \leq VDR \leq 0.994 \times (VLCD-GND)$ - Limit of potential difference between V5 and GND : $\frac{R}{9.5 \times R + VR} \times (VLCD-GND) \geq 0.4 [V]$ - Limit if potential difference between VLCD and V1 : $\frac{VR}{9.5 \times R + VR} \times (VLCD-GND) \geq 0.4 [V]$
1/9 bias drive	$\frac{9 \times R}{9 \times R + VR} \times (VLCD - GND)$	<ul style="list-style-type: none"> - LCD drive voltage adjustment range : $0.737 \times (VLCD-GND) \leq VDR \leq 0.994 \times (VLCD-GND)$ - Limit of potential difference between V5 and GND : $\frac{R}{9 \times R + VR} \times (VLCD-GND) \geq 0.4 [V]$ - Limit if potential difference between VLCD and V1 : $\frac{VR}{9 \times R + VR} \times (VLCD-GND) \geq 0.4 [V]$
1/8 bias drive	$\frac{8 \times R}{8 \times R + VR} \times (VLCD - GND)$	<ul style="list-style-type: none"> - LCD drive voltage adjustment range : $0.714 \times (VLCD-GND) \leq VDR \leq 0.993 \times (VLCD-GND)$ - Limit of potential difference between V5 and GND : $\frac{R}{8 \times R + VR} \times (VLCD-GND) \geq 0.4 [V]$ - Limit if potential difference between VLCD and V1 : $\frac{VR}{8 \times R + VR} \times (VLCD-GND) \geq 0.4 [V]$
1/7 bias drive	$\frac{7 \times R}{7 \times R + VR} \times (VLCD - GND)$	<ul style="list-style-type: none"> - LCD drive voltage adjustment range : $0.686 \times (VLCD-GND) \leq VDR \leq 0.993 \times (VLCD-GND)$ - Limit of potential difference between V5 and GND : $\frac{R}{7 \times R + VR} \times (VLCD-GND) \geq 0.4 [V]$ - Limit if potential difference between VLCD and V1 : $\frac{VR}{7 \times R + VR} \times (VLCD-GND) \geq 0.4 [V]$
1/6 bias drive	$\frac{6 \times R}{6 \times R + VR} \times (VLCD - GND)$	<ul style="list-style-type: none"> - LCD drive voltage adjustment range : $0.652 \times (VLCD-GND) \leq VDR \leq 0.992 \times (VLCD-GND)$ - Limit of potential difference between V5 and GND : $\frac{R}{6 \times R + VR} \times (VLCD-GND) \geq 0.4 [V]$ - Limit if potential difference between VLCD and V1 : $\frac{VR}{6 \times R + VR} \times (VLCD-GND) \geq 0.4 [V]$
1/5 bias drive	$\frac{5 \times R}{5 \times R + VR} \times (VLCD - GND)$	<ul style="list-style-type: none"> - LCD drive voltage adjustment range : $0.610 \times (VLCD-GND) \leq VDR \leq 0.990 \times (VLCD-GND)$ - Limit of potential difference between V5 and GND : $\frac{R}{5 \times R + VR} \times (VLCD-GND) \geq 0.4 [V]$ - Limit if potential difference between VLCD and V1 : $\frac{VR}{5 \times R + VR} \times (VLCD-GND) \geq 0.4 [V]$
1/4 bias drive	$\frac{4 \times R}{4 \times R + VR} \times (VLCD - GND)$	<ul style="list-style-type: none"> - LCD drive voltage adjustment range : $0.556 \times (VLCD-GND) \leq VDR \leq 0.988 \times (VLCD-GND)$ - Limit of potential difference between V5 and GND : $\frac{R}{4 \times R + VR} \times (VLCD-GND) \geq 0.4 [V]$ - Limit if potential difference between VLCD and V1 : $\frac{VR}{4 \times R + VR} \times (VLCD-GND) \geq 0.4 [V]$

Liquid Crystal Display Drive Bias Selector

An optimum liquid crystal display bias value can be selected using BS2-0 bits, according to the liquid crystal drive duty ratio setting (NL3-0 bits). Liquid crystal display drive duty ratio and bias value can be displayed while switching software applications to match the LCD panel display status. The optimum bias value calculated using the following expression is an ideal value where the optimum contrast is obtained. Driving by using a lower value than the optimum bias value provides lower contrast and lower liquid crystal display voltage (potential difference between V1 and GND). When the liquid crystal display voltage is insufficient even if a five-times booster is used or output voltage is lowered because the battery life has been reached, the display can be made easier to see by lowering the liquid crystal bias.

The liquid crystal display can be adjusted by using the contrast adjustment register (CT4-0 bits) and selecting the booster output level (BT1/0 bits).

$$\text{Optimum bias value for 1/N duty ratio drive voltage} = \frac{1}{\sqrt{N+1}}$$

Table 21 Optimum Drive Bias Values

LCD drive duty ratio	1/80	1/72	1/64	1/56	1/48	1/40	1/32	1/24	1/16	1/8
(NL3-0 set value)	1001	1000	0111	0110	0101	0100	0011	0010	0001	0000
Optimum drive bias value	1/10	1/9.5	1/9	1/8	1/8	1/7	1/6	1/6	1/5	1/4
(BS2-0 set value)	000	001	010	011	011	100	101	101	110	111

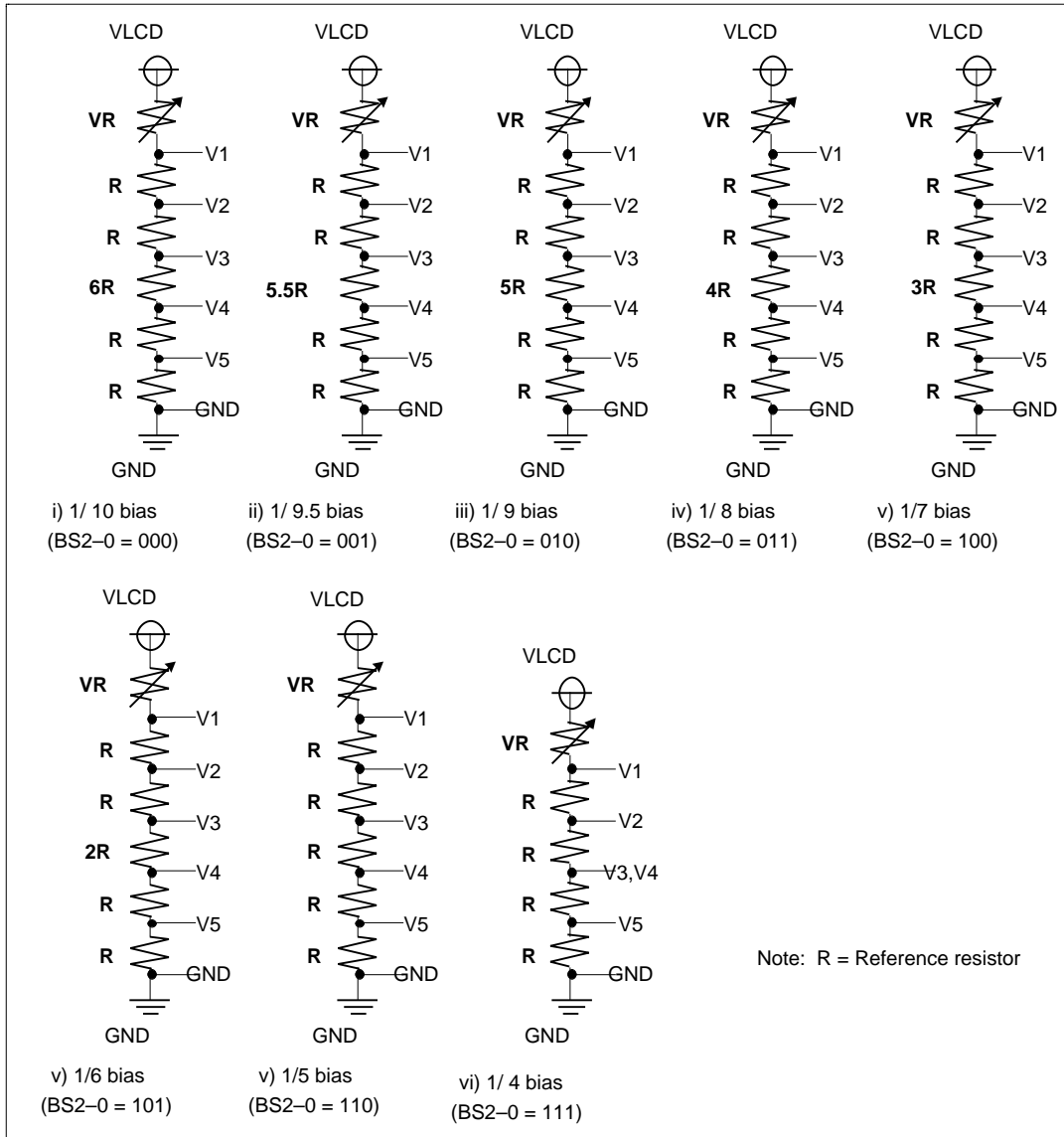

Figure 28 Liquid Crystal Display Drive Bias Circuit

LCD Panel Interface

The HD66740 has a function for changing the common driver/segment driver output shift direction using the CMS bit and SGS bit to meet the chip mounting positions of the HD66740. This is to facilitate the interface wiring to the LCD panel with COG or TCP installed.

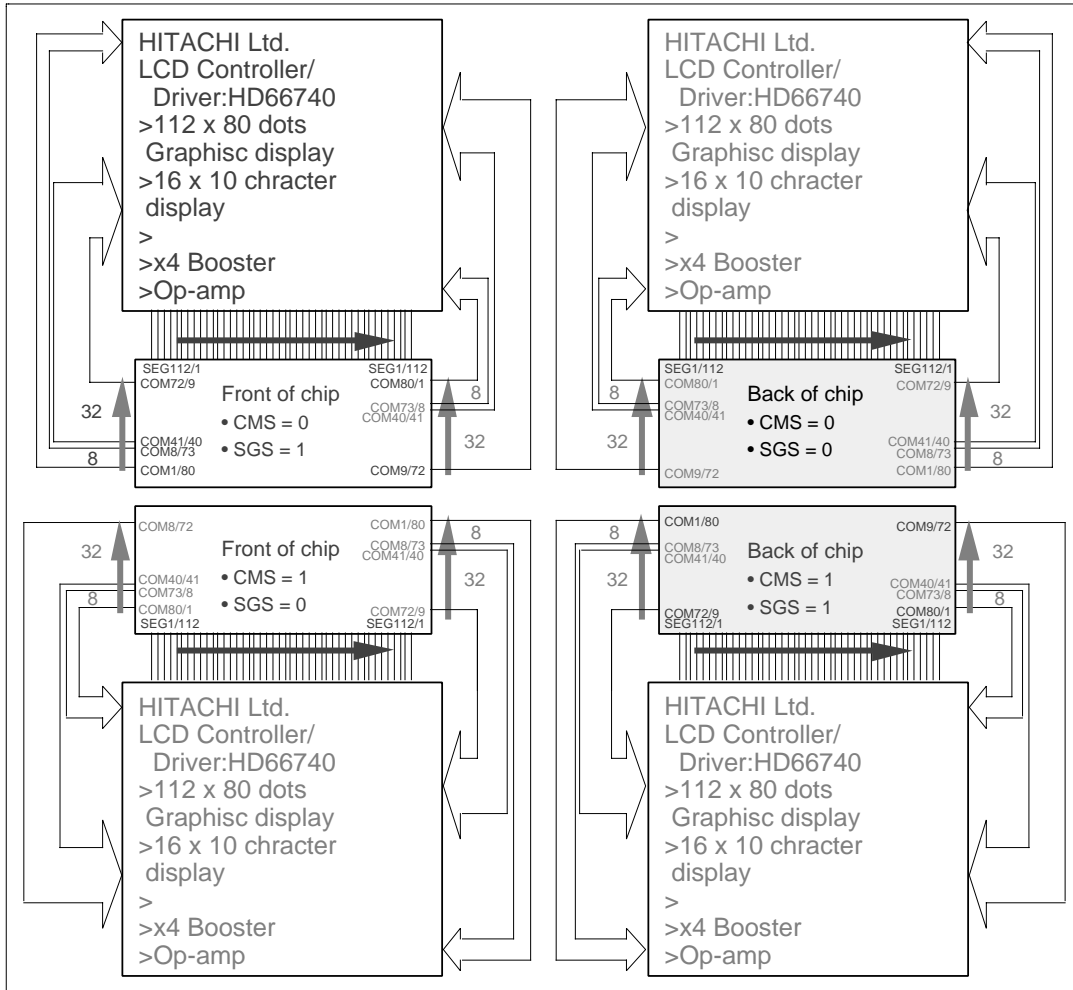

Figure 29 1/80 Duty Drive Pattern Wiring

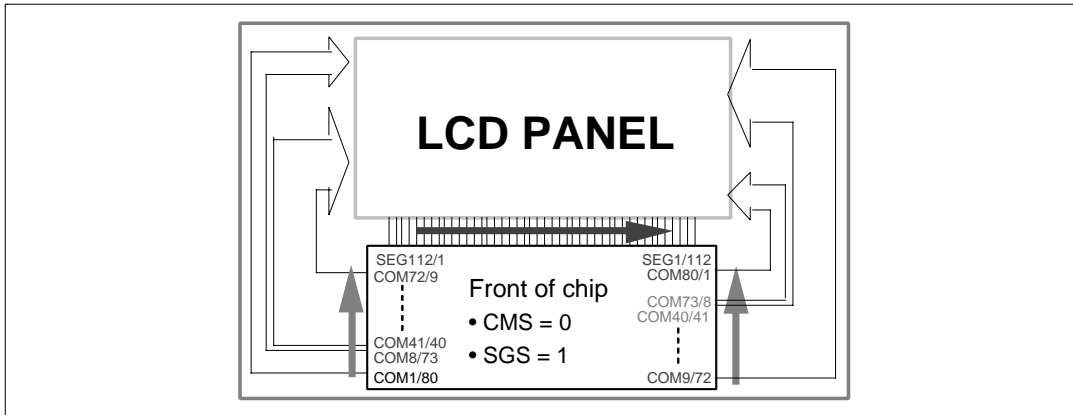

Figure 30 1-line Display Pattern Wiring

Table 22 Number of Left and Right Extension Lines of Common Driver

Drive Duty Ratio	Left Edge of Screen	Right Edge of Screen
1/48	16 (COM1–8, 41–48)	32 (COM9–40)
1/56	24 (COM1–8, 41–56)	32 (COM9–40)
1/64	32 (COM1–8, 41–64)	32 (COM9–40)
1/72	40 (COM1–8, 41–72)	32 (COM9–40)
1/80	40 (COM1–8, 41–72)	40 (COM9–40, 73–80)

Graphics Display Function

In the graphics display mode, kanji characters, special symbols, and graphics icons can be displayed. Up to 112 x 80-dot display is allowed using the CGRAM. Thus, for a 12 x 13-dot kanji font, up to a 6-line x 9-character kanji display, and for a 14 x 15-dot kanji font, up to a 6-line x 8-character kanji display, and for a 16 x 16-dot kanji font, up to a 5-line x 6-character kanji display are allowed.

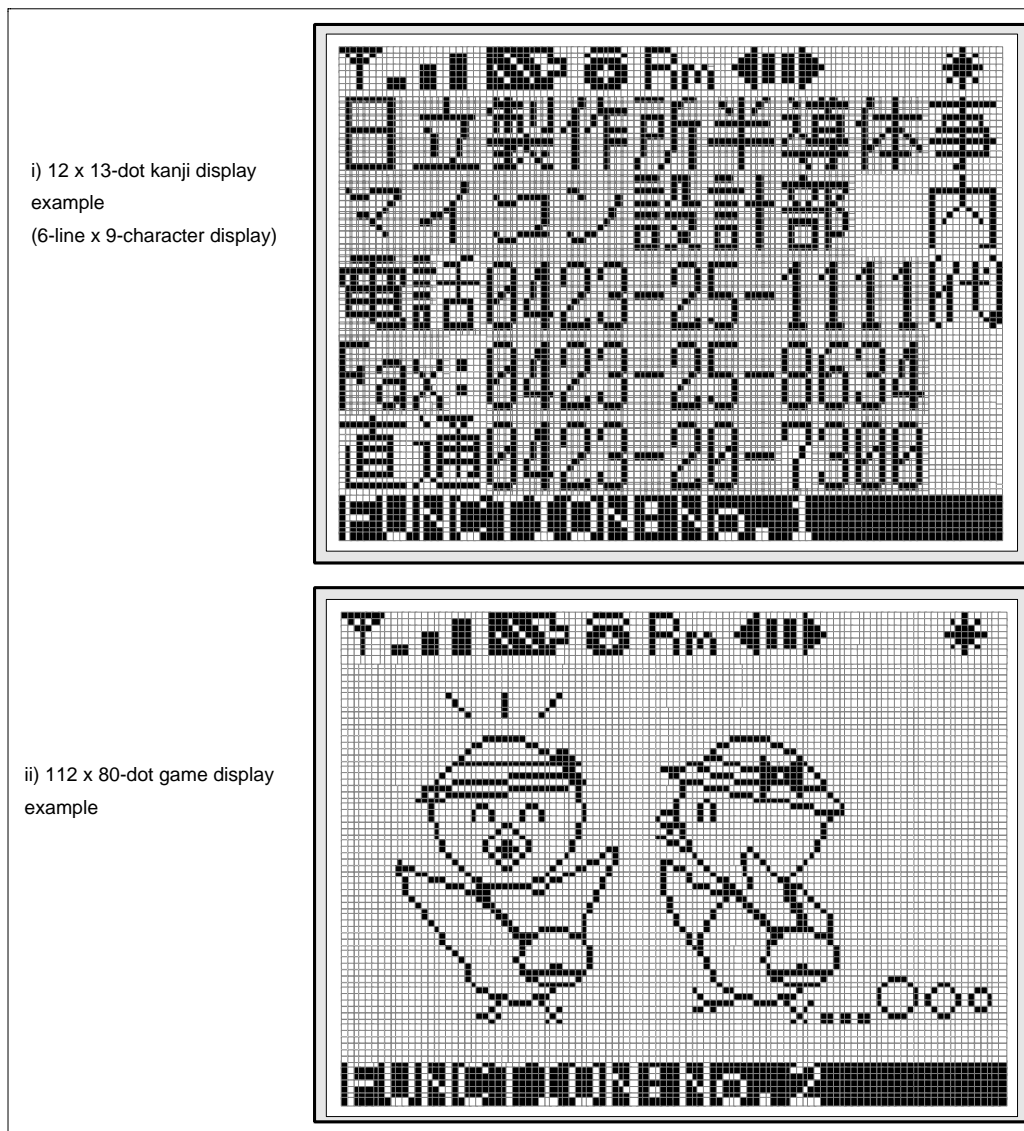

Figure 31 Display Example in Graphics Display Mode

Vertical Smooth Scroll Display

The HD66740 can scroll character and graphics display vertically in units of raster-rows. This is achieved by writing display data into a one-line area that is not being used for display. In other words,

HITACHI

HD66740

one line can be used to achieve continuous smooth vertical scroll even in a 9-line or less display. Here, after the 10th line is displayed, the first line is displayed again. When the 10th line is fully displayed, all one-line display data must be rewritten immediately after scrolling because there is no non-displayed area. Additionally, when display areas of a graphics icon such as a pictogram or a menu bar are partially fixed-displayed, the remaining areas can be displayed. For details, see the Partial Smooth Scroll Display Function section.

Specifically, this function is controlled by incrementing or decrementing the value in the display-start line bits (SL2 to SL0) and display-start raster-row bits (SN3 to SN0) by 1. For example, to smoothly scroll up, first set line bits SN3 to SN0 to 0000, and increment SL2 to SL0 by 1 from 000 to 111 to scroll seven raster-rows. Then increment line bits SN3 to SN0 to 0001, and again increment SL2 to SL0 by 1 from 000 to 111. If the vertical double-height display is at the top of the line, scrolling is done by each two raster-row.

When the response speed of the liquid crystal is low or when high-speed scrolling is needed, two- to four-raster-row scrolling is recommended.

HITACHI

Setting Instructions (10-line Display: NL3-0 = 1001)

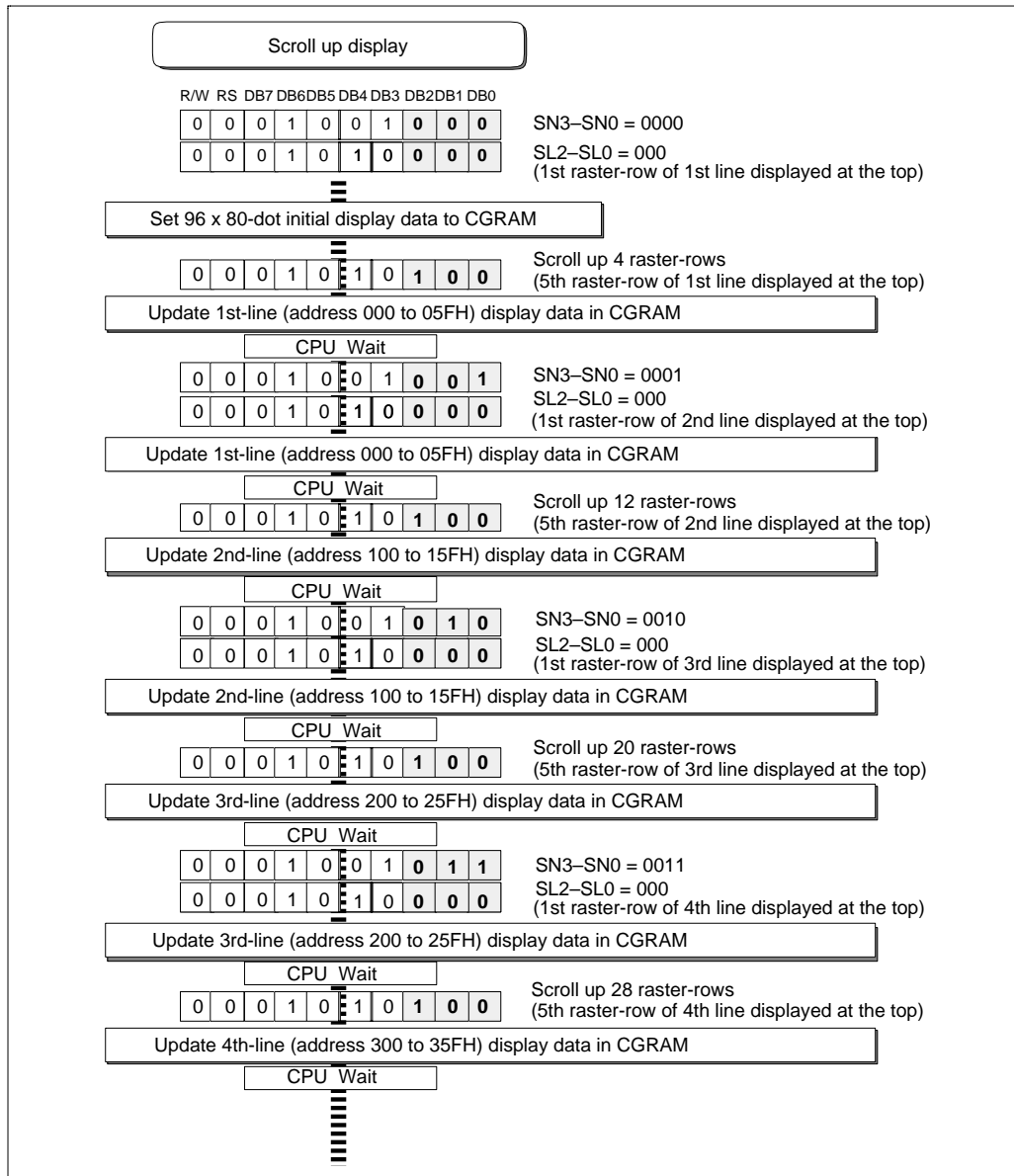

Figure 32 Setting Instructions for Vertical Smooth Scroll

HD66740

Partial Smooth Scroll Display Function

The HD66740 can partially fixed-display the areas of a graphics icon, such as a pictogram or a menu bar, and perform vertical smooth scrolling of the remaining bit-map areas. Since the PS1 to PS0 bits do not perform smooth scrolling of the upper first to third display lines but does fixed-display, pictograms can be placed. When CN1 to CN0 bits are set to 10, the first line is displayed at the bottom edge of the LCD screen, and the menu bar can be fixed-displayed at the bottom. This function can largely control the bit-map rewrite frequencies and reduce software loads.

HITACHI

Table 23 Bit Setting and Display Lines

Bit Setting	COM Position	CN1-0 = 00					CN1-0 = 10				
		SN3-0 = 0000	SN3-0 = 0001	SN3-0 = 0010	SN3-0 = 0011	SN3-0 = 0011	SN3-0 = 0000	SN3-0 = 0001	SN3-0 = 0010	SN3-0 = 0011	SN3-0 = 0100
PS1-0 = 00	COM1	1st line	2nd line	3rd line	4th line	5th line	2nd line	3rd line	4th line	5th line	6th line
		2nd line	3rd line	4th line	5th line	6th line	3rd line	4th line	5th line	6th line	7th line
		3rd line	4th line	5th line	6th line	7th line	4th line	5th line	6th line	7th line	8th line
		4th line	5th line	6th line	7th line	8th line	5th line	6th line	7th line	8th line	9th line
		5th line	6th line	7th line	8th line	9th line	6th line	7th line	8th line	9th line	10th line
		6th line	7th line	8th line	9th line	10th line	7th line	8th line	9th line	10th line	1st line
		7th line	8th line	9th line	10th line	1st line	8th line	9th line	10th line	1st line	2nd line
		8th line	9th line	10th line	1st line	2nd line	9th line	10th line	1st line	2nd line	3rd line
		9th line	10th line	1st line	2nd line	3rd line	10th line	1st line	2nd line	3rd line	4th line
		COM80	10th line	1st line	2nd line	3rd line	4th line	1st line	2nd line	3rd line	4th line
PS1-0 = 01	COM1	1st line	1st line	1st line	1st line	1st line	1st line	2nd line	3rd line	4th line	5th line
		1st line	2nd line	3rd line	4th line	5th line	2nd line	3rd line	4th line	5th line	6th line
		2nd line	3rd line	4th line	5th line	6th line	3rd line	4th line	5th line	6th line	7th line
		3rd line	4th line	5th line	6th line	7th line	4th line	5th line	6th line	7th line	8th line
		4th line	5th line	6th line	7th line	8th line	5th line	6th line	7th line	8th line	9th line
		5th line	6th line	7th line	8th line	9th line	6th line	7th line	8th line	9th line	10th line
		6th line	7th line	8th line	9th line	10th line	7th line	8th line	9th line	10th line	2nd line
		7th line	8th line	9th line	10th line	2nd line	8th line	9th line	10th line	2nd line	3rd line
		8th line	9th line	10th line	2nd line	3rd line	9th line	10th line	2nd line	3rd line	4th line
		COM80	9th line	10th line	2nd line	3rd line	4th line	1st line	1st line	1st line	1st line
PS1-0 = 10	COM1	1st line	1st line	1st line	1st line	1st line	2nd line	2nd line	2nd line	2nd line	2nd line
		2nd line	2nd line	2nd line	2nd line	2nd line	1st line	2nd line	3rd line	4th line	5th line
		1st line	2nd line	3rd line	4th line	5th line	2nd line	3rd line	4th line	5th line	6th line
		2nd line	3rd line	4th line	5th line	6th line	3rd line	4th line	5th line	6th line	7th line
		3rd line	4th line	5th line	6th line	7th line	4th line	5th line	6th line	7th line	8th line
		4th line	5th line	6th line	7th line	8th line	5th line	6th line	7th line	8th line	9th line
		5th line	6th line	7th line	8th line	9th line	6th line	7th line	8th line	9th line	10th line
		6th line	7th line	8th line	9th line	10th line	7th line	8th line	9th line	10th line	3rd line
		7th line	8th line	9th line	10th line	3rd line	8th line	9th line	10th line	3rd line	4th line
		COM80	8th line	9th line	10th line	3rd line	4th line	1st line	1st line	1st line	1st line
PS1-0 = 11	COM1	1st line	1st line	1st line	1st line	1st line	2nd line	2nd line	2nd line	2nd line	2nd line
		2nd line	2nd line	2nd line	2nd line	2nd line	3rd line	3rd line	3rd line	3rd line	3rd line
		3rd line	3rd line	3rd line	3rd line	3rd line	1st line	2nd line	3rd line	4th line	5th line
		1st line	2nd line	3rd line	4th line	5th line	2nd line	3rd line	4th line	5th line	6th line
		2nd line	3rd line	4th line	5th line	6th line	3rd line	4th line	5th line	6th line	7th line
		3rd line	4th line	5th line	6th line	7th line	4th line	5th line	6th line	7th line	8th line
		4th line	5th line	6th line	7th line	8th line	5th line	6th line	7th line	8th line	9th line
		5th line	6th line	7th line	8th line	9th line	6th line	7th line	8th line	9th line	10th line
		6th line	7th line	8th line	9th line	10th line	7th line	8th line	9th line	10th line	4th line
		COM80	7th line	8th line	9th line	10th line	4th line	1st line	1st line	1st line	1st line

- Notes:
1. The shadow lines above are fixed-displayed. They do not depend on the setting values of the SN3-0 or SL3-0 bits.
 2. The SN3-0 and SL3-0 bits specify the next first scroll display line of the fixed-displayed lines.
 3. When the drive duty ratio is nine lines (1/72 duty ratio) or less and CN1-0 is 10, the first line shifts to the last displayed line.

Partial Smooth Scroll Display Examples

Table 24 Data Setting to the CGRAM Partial Smooth Scroll Display Examples

CGRAM Address	CGRAM Data
"000" to "06F"	
"080" to "0EF"	〒.# 123 45 67 89 01 23
"100" to "16F"	HITACHI LTD Seni
"180" to "1EF"	conductor 1234567890
"200" to "26F"	Kodaira 1234567890
"280" to "2EF"	Tokyo, 1234567890
"300" to "36F"	Japan 1234567890
"380" to "3EF"	T187 1234567890
"400" to "46F"	TEL: 0423-25-1111
"480" to "4EF"	

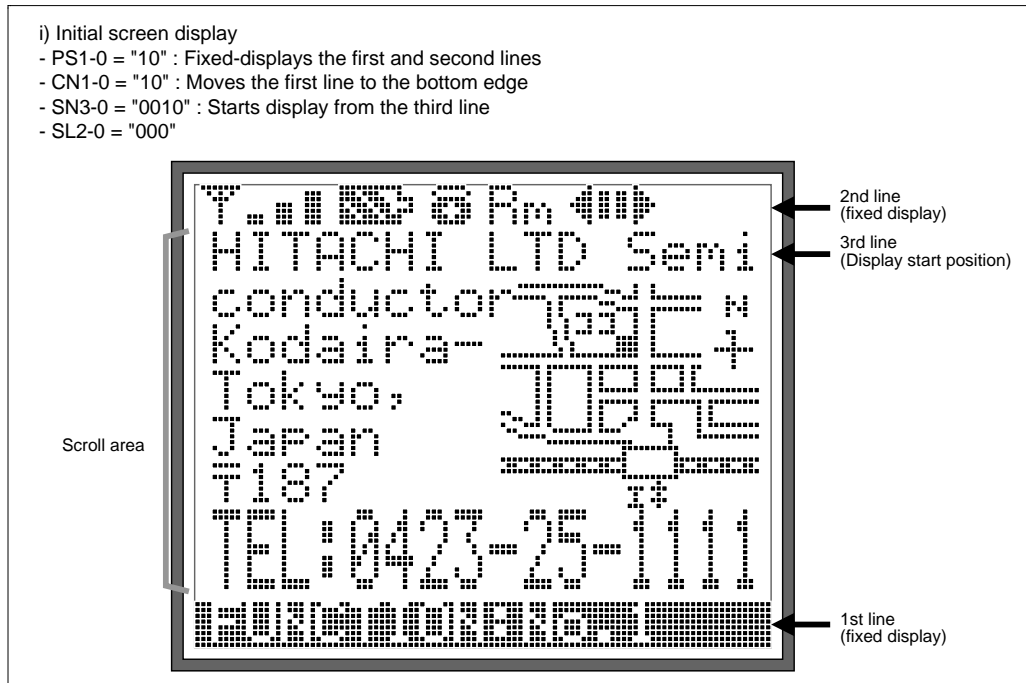

Figure 33 Example of Initial Screen in the Partial Smooth Scroll Mode

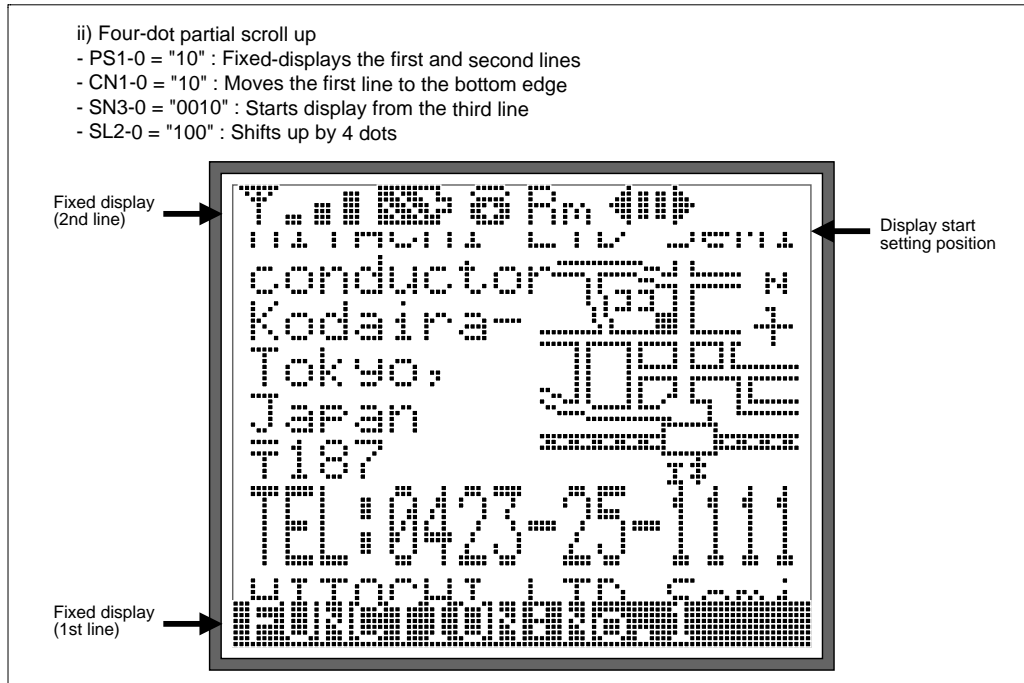

Figure 34 Example of Display Screen in the Partial Smooth Scroll Mode (1)

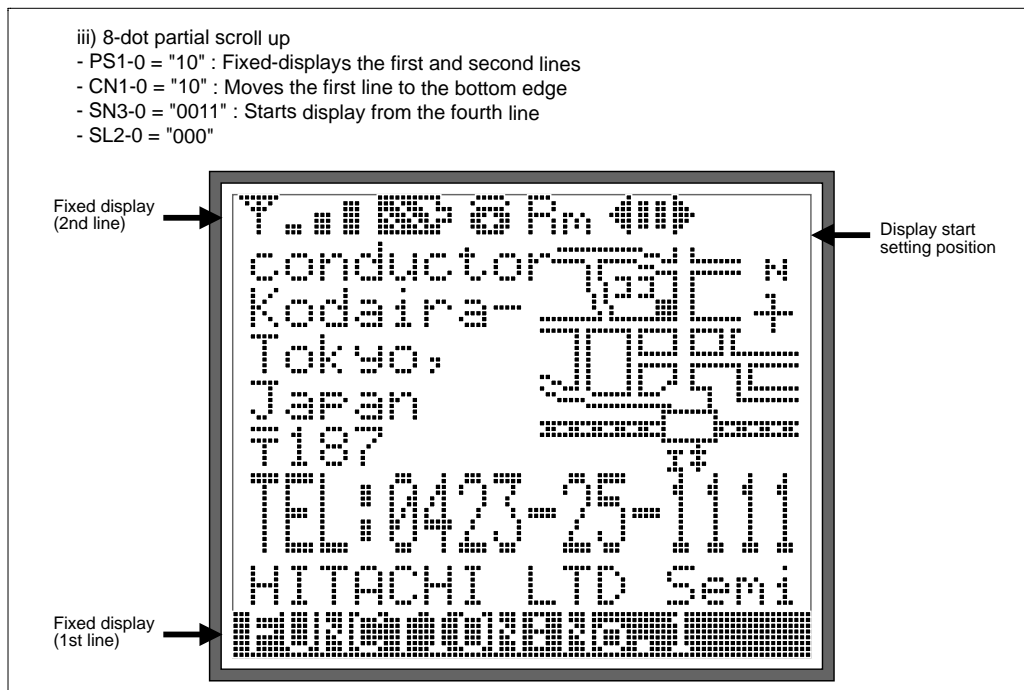

Figure 35 Example of Display Screen in the Partial Smooth Scroll Mode (2)

HITACHI

Reversed Display Function

The HD66740 can display character/graphics display sections by black-and-white reversal. Black-and-white reversal can be easily displayed when REV is set to 1.

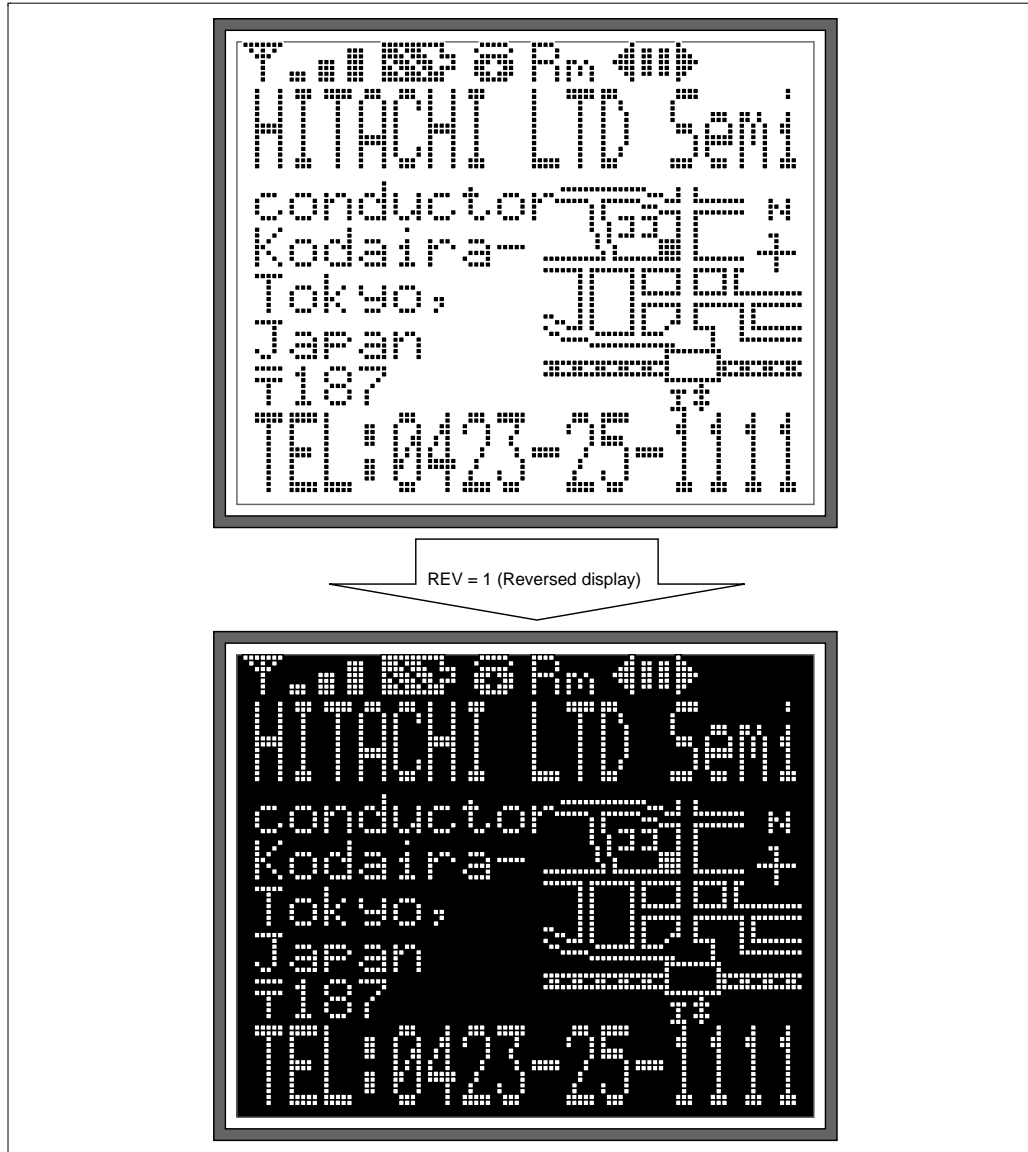

Figure 37 Reversed Display

HITACHI

HD66740

Partial-display-on Function

The HD66740 can program the liquid crystal display drive duty ratio setting (NL3-0 bits), liquid crystal display drive bias value selection (BS2-0 bits), boost output level selection (BT1/0 bit) and contrast adjustment (CT5-0 bits). For example, in the 10-line display mode (1/80 duty ratio), the HD66740 can selectively drive only the center of the screen or only the top or bottom of the screen by combining these register functions and the centering display (CN1-0 bit) function. This is called partial-display-on. Lowering the liquid crystal display drive duty ratio as required saves the liquid crystal display drive voltage, thus reducing internal current consumption. This is suitable for four-line display of a calendar or time, or the display of only graphics icons (pictograms) at the top or bottom of the screen, which needs to be continuous in the system standby state with minimal current consumption. Here, the non-displayed lines are constantly driven by the unselected level voltage, thus turning off the LCD for the lines.

In general, lowering the liquid crystal display drive duty ratio decreases the optimum liquid crystal display drive voltage and liquid crystal display drive bias value. This reduces output multiplying factors in the booster and greatly controls consumption current.

Table 26 Partial-display-on Function (10-line Display)

Item	Normal 10-line Display	Partial-on Display (Limited 4-line Display)	
LCD screen	10th line displayed	Only four lines on the center of the screen (from the 3rd to 6th lines)	Only four lines at the top and bottom of the screen (from the 1st to 3rd and 10th lines)
LCD drive position shift	Not necessary (CN1-0 = 00)	Necessary (CN1-0 = 01)	Necessary (CN1-0 = 01)
LCD drive duty ratio	1/80 (NL3-0 = 1001)	1/32 (NL3-0 = 0011)	1/32 (NL3-0 = 0011)
LCD drive bias value (optimum)	1/10 (BS2-0 = 000)	1/6 (BS2-0 = 101)	1/6 (BS2-0 = 101)
LCD drive voltage*	12 V to 15 V (adjustable using CT5-0)	6 V to 8 V (adjustable using CT5-0)	6 V to 8 V (adjustable using CT5-0)
Boosting output multiplying factor	Five times (BT1-0 = 10)	Triple (BT1-0 = 00)	Triple (BT1-0 = 00)
Frame frequency (fosc = 90 kHz)	70 Hz	88 Hz	88 Hz

Note: The LCD drive voltage depends on the LCD materials which are actually used. Since the LCD drive voltage is high when the LCD drive duty ratio is high, a low duty ratio is suitable for low-power consumption.

HITACHI

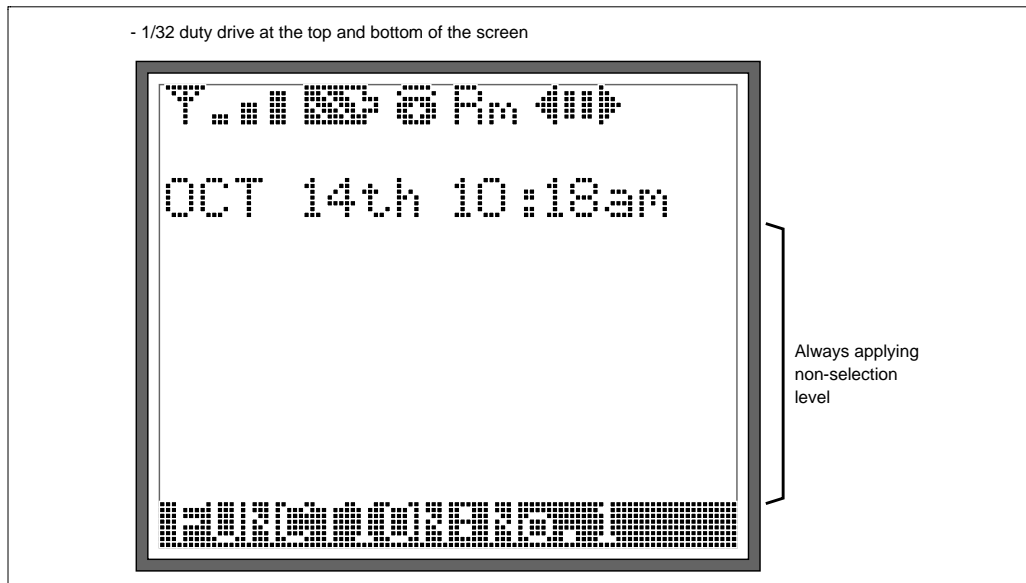

Figure 38 Partial-on Display (Date and Time Indicated) (1)

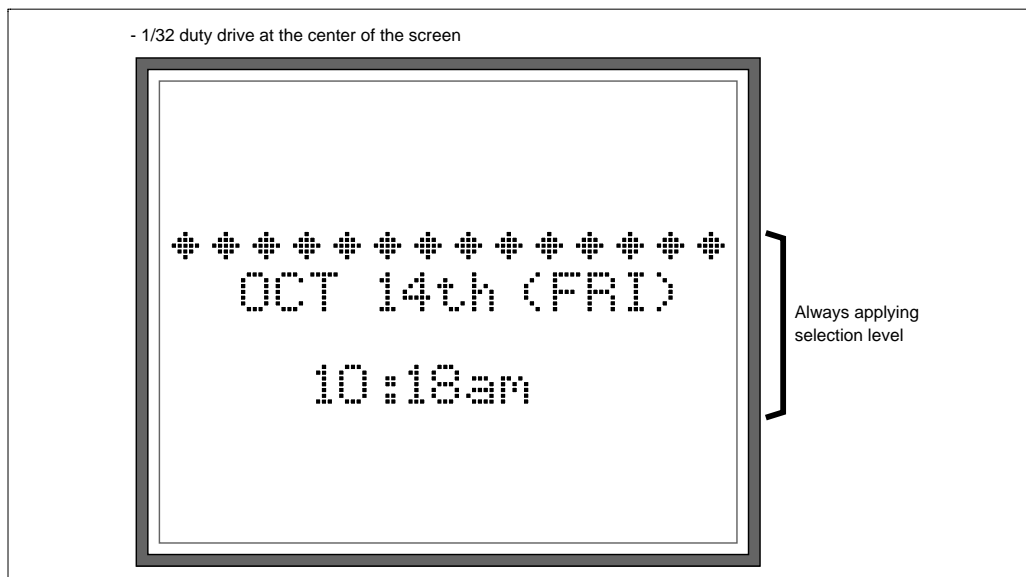

Figure 39 Partial-on Display (Date and Time Indicated) (2)

HD66740

Sleep Mode

Setting the sleep mode bit (SLP) to 1 puts the HD66740 in the sleep mode, where the device stops all internal display operations, thus reducing current consumption. Specifically, LCD drive is completely halted. Here, all the SEG (SEG1 to SEG112) and COM (COM1 to COM80) pins output the GND level, resulting in no display. If the AMP bit is set to 0 in the sleep mode, the LCD drive power supply can be turned off, reducing the total current consumption of the LCD module.

Table 27 Comparison of Sleep Mode and Standby Mode

Function	Sleep Mode (SLP = 1)	Standby Mode (STB = 1)
LCD control	Turned off	Turned off
R-C oscillation circuit	Operates normally	Halted

Standby Mode

Setting the standby mode bit (STB) to 1 puts the HD66740 in the standby mode, where the device stops completely, halting all internal operations including the R-C oscillation circuit, thus further reducing current consumption compared to that in the sleep mode. Specifically, character and segment displays, which are controlled by the multiplexing drive method, are completely halted. Here, all the SEG (SEG1 to SEG112) and COM (COM1 to COM80) pins output the GND level, resulting in no display. If the AMP bit is set to 0 in the standby mode, the LCD drive power supply can be turned off.

During the standby mode, no instructions can be accepted other than the start-oscillation. To cancel the standby mode, issue the start-oscillation instruction to stabilize R-C oscillation before setting the STB bit to 0.

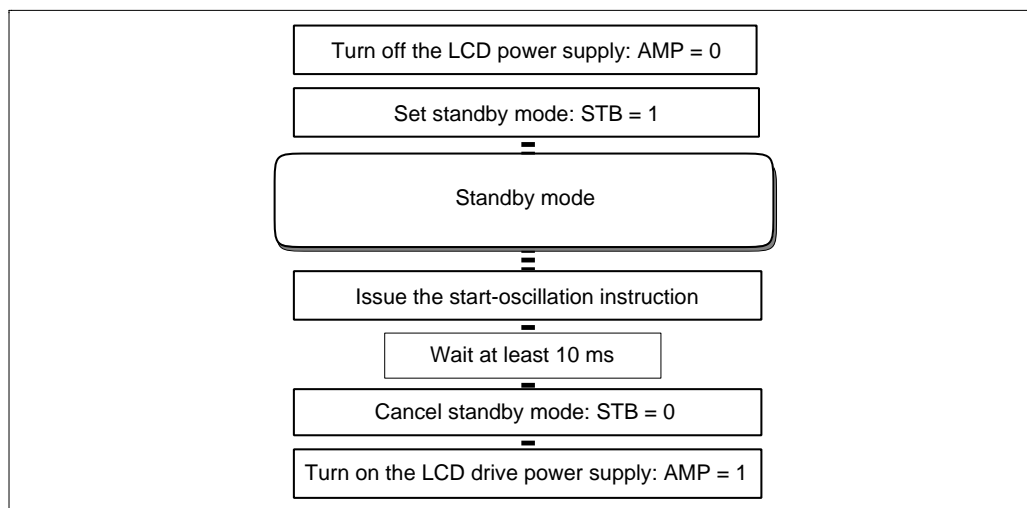

Figure 40 Procedure for Setting and Canceling Standby Mode

HD66740

Absolute Maximum Ratings

Item	Symbol	Unit	Value	Notes*
Power supply voltage (1)	V_{CC}	V	-0.3 to +4.6	1, 2
Power supply voltage (2)	$V_{LCD} - GND$	V	-0.3 to +16.0	1, 3
Input voltage	V_t	V	-0.3 to $V_{CC} + 0.3$	1
Operating temperature	T_{opr}	°C	-40 to +85	1, 4
Storage temperature	T_{stg}	°C	-55 to +110	1, 5

Notes: 1. If the LSI is used above these absolute maximum ratings, it may become permanently damaged. Using the LSI within the following electrical characteristics limits is strongly recommended for normal operation. If these electrical characteristic conditions are also exceeded, the LSI will malfunction and cause poor reliability.

2. $V_{CC} > GND$ must be maintained.

3. $V_{LCD} > GND$ must be maintained.

4. For bare die and wafer products, specified up to 85°C.

5. This temperature specifications apply to the TCP package.

HITACHI

DC Characteristics ($V_{CC} = 1.8$ to 3.6 V, $T_a = -40$ to $+85^\circ\text{C}^{*1}$)

Item	Symbol	Min	Typ	Max	Unit	Test Condition	Notes
Input high voltage	V_{IH}	$0.7 V_{CC}$	—	V_{CC}	V		2, 3
Input low voltage	V_{IL}	-0.3	—	$0.15 V_{CC}$	V	$V_{CC} = 1.8$ to 2.7 V	2, 3
Input low voltage	V_{IL}	-0.3	—	$0.15 V_{CC}$	V	$V_{CC} = 2.7$ to 3.6 V	2, 3
Output high voltage (SDA, DB0-7 pins)	V_{OH1}	$0.75 V_{CC}$	—	—	V	$I_{OH} = -0.1$ mA	2, 4
Output low voltage (SDA, DB0-7 pins)	V_{OL1}	—	—	$0.2 V_{CC}$	V	$V_{CC} = 1.8$ to 2.7 V, $I_{OL} = 0.1$ mA	2
Output low voltage (SDA, DB0-7 pins)	V_{OL1}	—	—	$0.15 V_{CC}$	V	$V_{CC} = 2.7$ to 3.6 V, $I_{OL} = 0.1$ mA	2
Driver ON resistance (COM pins)	R_{COM}	—	3	20	k Ω	$\pm I_d = 0.05$ mA, $V_{LCD} = 10$ V	5
Driver ON resistance (SEG pins)	R_{SEG}	—	3	30	k Ω	$\pm I_d = 0.05$ mA, $V_{LCD} = 10$ V	5
I/O leakage current	I_{LI}	-1	—	1	μA	$V_{in} = 0$ to V_{CC}	6
Pull-up MOS current (DB0-7, SDA pins)	$-I_p$	1	10	40	μA	$V_{CC} = 3$ V, $V_{in} = 0$ V	2
Current consumption during normal operation (V_{CC} -GND)	I_{OP}	—	32	55	μA	R-C oscillation, $V_{CC} = 3$ V, $T_a = 25^\circ\text{C}$, f_{OSC} $= 86$ kHz (1/72 duty)	7, 8
Current consumption during sleep mode (V_{CC} -GND)	I_{SL}	—	11	—	μA	R-C oscillation, $V_{CC} = 3$ V, $T_a = 25^\circ\text{C}$, f_{OSC} $= 86$ kHz (1/72 duty)	7, 8
Current consumption during standby mode (V_{CC} -GND)	I_{ST}	—	0.1	5	μA	$V_{CC} = 3$ V, $T_a = 25^\circ\text{C}$	7, 8
LCD drive power supply current (V_{LCD} -GND)	I_{LCD}	—	20	35	μA	$V_{LCD} = 12$ V, $T_a = 25^\circ\text{C}$, $f_{OSC} = 86$ kHz, 1/9 bias, VTEST3="High"	8
LCD drive voltage ($V_{LCD} - \text{GND}$)	V_{LCD}	4.5	—	15.0	V		9

Note: For the numbered notes, refer to the Electrical Characteristics Notes section following these tables.

HD66740

Booster Characteristics

Item	Symbol	Min	Typ	Max	Unit	Test Condition	Notes
Triple-boost output voltage (VLOUT pin)	V_{UP3}	8.5	8.9	9.0	V	$V_{CC} = V_{ci} = 3.0\text{ V}$, $I_o = 30\ \mu\text{A}$, $C = 1\ \mu\text{F}$, $f_{osc} = 86\ \text{kHz}$, $T_a = 25^\circ\text{C}$	12
Quadruple-boost output voltage (VLOUT pin)	V_{UP4}	11.5	11.8	12.0	V	$V_{CC} = V_{ci} = 3.0\text{ V}$, $I_o = 30\ \mu\text{A}$, $C = 1\ \mu\text{F}$, $f_{osc} = 86\ \text{kHz}$, $T_a = 25^\circ\text{C}$	12
Five-times-boost output voltage (VLOUT pin)	V_{UP5}	14.5	14.8	15.0	V	$V_{CC} = V_{ci} = 3.0\text{ V}$, $I_o = 30\ \mu\text{A}$, $C = 1\ \mu\text{F}$, $f_{osc} = 86\ \text{kHz}$, $T_a = 25^\circ\text{C}$	12
Use range of boost output voltage	V_{UP3} , V_{UP4} , V_{UP5}	V_{CC}	—	15.0	V	For triple to Five-times boost	12

Note: For the numbered notes, refer to the Electrical Characteristics Notes section following these tables.

AC Characteristics ($V_{CC} = 1.8$ to 3.6 V, $T_a = -40$ to $+85^\circ\text{C}^{*1}$)
Clock Characteristics ($V_{CC} = 1.8$ to 3.6 V)

Item	Symbol	Min	Typ	Max	Unit	Test Condition	Notes
External clock frequency	fcp	50	75	100	kHz		10
External clock duty ratio	Duty	45	50	55	%		10
External clock rise time	trcp	—	—	0.2	μs		10
External clock fall time	tfcf	—	—	0.2	μs		10
R-C oscillation clock	f _{OSC}	69	86	103	kHz	Rf = 270 k Ω , V _{CC} = 3 V	11

Note: For the numbered notes, refer to the Electrical Characteristics Notes section following these tables.

68-system Bus Interface Timing Characteristics
(V_{CC} = 1.8 to 2.7 V)

Item		Symbol	Min	Typ	Max	Unit	Test Condition
Enable cycle time	Write	t _{CYCE}	600	—	—	ns	Figure 47
	Read	t _{CYCE}	800	—	—		
Enable high-level pulse width	Write	PW _{EH}	120	—	—	ns	Figure 47
	Read	PW _{EH}	350	—	—		
Enable low-level pulse width	Write	PW _{EL}	300	—	—	ns	Figure 47
	Read	PW _{EL}	300	—	—		
Enable rise/fall time		t _{Er} , t _{Ef}	—	—	25	ns	Figure 47
Setup time (RS, R/W to E, CS*)		t _{ASE}	50	—	—	ns	Figure 47
Address hold time		t _{AHE}	20	—	—	ns	Figure 47
Write data setup time		t _{DSWE}	60	—	—	ns	Figure 47
Write data hold time		t _{HE}	20	—	—	ns	Figure 47
Read data delay time		t _{DDRE}	—	—	300	ns	Figure 47
Read data hold time		t _{DHRE}	5	—	—	ns	Figure 47

HITACHI

HD66740

(V_{CC} = 2.7 to 3.6 V)

Item		Symbol	Min	Typ	Max	Unit	Test Condition
Enable cycle time	Write	t _{CYCE}	380	—	—	ns	Figure 47
	Read	t _{CYCE}	500	—	—		
Enable high-level pulse width	Write	PW _{EH}	70	—	—	ns	Figure 47
	Read	PW _{EH}	250	—	—		
Enable low-level pulse width	Write	PW _{EL}	150	—	—	ns	Figure 47
	Read	PW _{EL}	150	—	—		
Enable rise/fall time		t _{Er} , t _{Ef}	—	—	25	ns	Figure 47
Setup time (RS, R/W to E, CS*)		t _{ASE}	50	—	—	ns	Figure 47
Address hold time		t _{AHE}	20	—	—	ns	Figure 47
Write data setup time		t _{DSWE}	60	—	—	ns	Figure 47
Write data hold time		t _{HE}	20	—	—	ns	Figure 47
Read data delay time		t _{DDRE}	—	—	200	ns	Figure 47
Read data hold time		t _{DHRE}	5	—	—	ns	Figure 47

HITACHI

80-system Bus Interface Timing Characteristics

(V_{CC} = 1.8 to 2.7 V)

Item		Symbol	Min	Typ	Max	Unit	Test Condition
Bus cycle time	Write	t _{CYCW}	600	—	—	ns	Figure 48
	Read	t _{CYCR}	800	—	—	ns	Figure 48
Write low-level pulse width		PW _{LW}	120	—	—	ns	Figure 48
Read low-level pulse width		PW _{LR}	350	—	—	ns	Figure 48
Write high-level pulse width		PW _{HW}	300	—	—	ns	Figure 48
Read high-level pulse width		PW _{HR}	300	—	—	ns	Figure 48
Write/Read rise/fall time		t _{WRf, WRr}	—	—	25	ns	Figure 48
Setup time (RS to CS*, WR*, RD*)		t _{AS}	50	—	—	ns	Figure 48
Address hold time		t _{AH}	20	—	—	ns	Figure 48
Write data setup time		t _{DSW}	60	—	—	ns	Figure 48
Write data hold time		t _H	20	—	—	ns	Figure 48
Read data delay time		t _{DDR}	—	—	300	ns	Figure 48
Read data hold time		t _{DHR}	5	—	—	ns	Figure 48

(V_{CC} = 2.7 to 3.6 V)

Item		Symbol	Min	Typ	Max	Unit	Test Condition
Bus cycle time	Write	t _{CYCW}	380	—	—	ns	Figure 48
	Read	t _{CYCR}	500	—	—	ns	Figure 48
Write low-level pulse width		PW _{LW}	70	—	—	ns	Figure 48
Read low-level pulse width		PW _{LR}	250	—	—	ns	Figure 48
Write high-level pulse width		PW _{HW}	150	—	—	ns	Figure 48
Read high-level pulse width		PW _{HR}	150	—	—	ns	Figure 48
Write/Read rise/fall time		t _{WRf, WRr}	—	—	25	ns	Figure 48
Setup time (RS to CS*, WR*, RD*)		t _{AS}	50	—	—	ns	Figure 48
Address hold time		t _{AH}	20	—	—	ns	Figure 48
Write data setup time		t _{DSW}	60	—	—	ns	Figure 48
Write data hold time		t _H	20	—	—	ns	Figure 48
Read data delay time		t _{DDR}	—	—	200	ns	Figure 48
Read data hold time		t _{DHR}	5	—	—	ns	Figure 48

HD66740

Clock-synchronized Serial Interface Timing Characteristics ($V_{CC} = 1.8$ to 3.6 V)**($V_{CC} = 1.8$ to 2.55 V)**

Item		Symbol	Min	Typ	Max	Unit	Test Condition
Serial clock cycle time	At write (receive)	t_{SCYC}	0.5	—	20	μs	Figure 49
	At read (send)	t_{SCYC}	1	—	20	μs	Figure 49
Serial clock high-level width	At write (receive)	t_{SCH}	230	—	—	ns	Figure 49
	At read (send)	t_{SCH}	480	—	—	ns	Figure 49
Serial clock low-level width	At write (receive)	t_{SCL}	230	—	—	ns	Figure 49
	At read (send)	t_{SCL}	480	—	—	ns	Figure 49
Serial clock rise/fall time		t_{scr} , t_{scf}	—	—	20	ns	Figure 49
Chip select setup time		t_{CSU}	60	—	—	ns	Figure 49
Chip select hold time		t_{CH}	200	—	—	ns	Figure 49
Serial input data setup time		t_{SISU}	100	—	—	ns	Figure 49
Serial input data hold time		t_{SIH}	100	—	—	ns	Figure 49
Serial output data delay time		t_{SOD}	—	—	400	ns	Figure 49
Serial output data hold time		t_{SOH}	5	—	—	ns	Figure 49

HITACHI

($V_{CC} = 2.55$ to 3.6 V)

Item		Symbol	Min	Typ	Max	Unit	Test Condition
Serial clock cycle time	At write (receive)	t_{SCYC}	0.2	—	20	μ s	Figure 49
	At read (send)	t_{SCYC}	0.5	—	20	μ s	Figure 49
Serial clock high-level width	At write (receive)	t_{SCH}	80	—	—	ns	Figure 49
	At read (send)	t_{SCH}	230	—	—	ns	Figure 49
Serial clock low-level width	At write (receive)	t_{SCL}	80	—	—	ns	Figure 49
	At read (send)	t_{SCL}	230	—	—	ns	Figure 49
Serial clock rise/fall time		t_{scr}, t_{scf}	—	—	20	ns	Figure 49
Chip select setup time		t_{CSU}	60	—	—	ns	Figure 49
Chip select hold time		t_{CH}	200	—	—	ns	Figure 49
Serial input data setup time		t_{SISU}	40	—	—	ns	Figure 49
Serial input data hold time		t_{SIH}	40	—	—	ns	Figure 49
Serial output data delay time		t_{SOD}	—	—	200	ns	Figure 49
Serial output data hold time		t_{SOH}	5	—	—	ns	Figure 49

Reset Timing Characteristics ($V_{CC} = 1.8$ to 3.6 V)

Item	Symbol	Min	Typ	Max	Unit	Test Condition
Reset low-level width	t_{RES}	1	—	—	ms	Figure 50

HD66740

I2C Bus Interface Timing Characteristics

(Vcc = 1.8 to 3.6 V)

Item	Symbol	Min	Typ	Max	Unit	Test Condition
SCL clock frequency	f_{SCL}	0	—	1300	kHz	Figure 51
SCL clock high-level pulse width	t_{SCLH}	120	—	—	ns	Figure 51
SCL clock low-level pulse width	t_{SCLL}	240	—	—	ns	Figure 51
SCL/SDA rise time	t_{Sr}	10	—	160	ns	Figure 51
SCL/SDA fall time	t_{Sf}	10	—	70	ns	Figure 51
Bus free time	t_{BUF}	240	—	—	ns	Figure 51
Start condition hold time	t_{STAH}	320	—	—	ns	Figure 51
Setup time for a repeated START condition	t_{STAS}	320	—	—	ns	Figure 51
Setup time for STOP condition	t_{STOS}	320	—	—	ns	Figure 51
SDA data setup time	t_{SDAS}	40	—	—	ns	Figure 51
SDA data hold time	t_{SDAH}	0	—	—	ns	Figure 51
SCL/SDA spike pulse width	t_{SP}	0	—	10	ns	Figure 51

HITACHI

Electrical Characteristics Notes

1. For bare die products, specified up to 85°C.
2. The following three circuits are I/O pin configurations (figure 41).

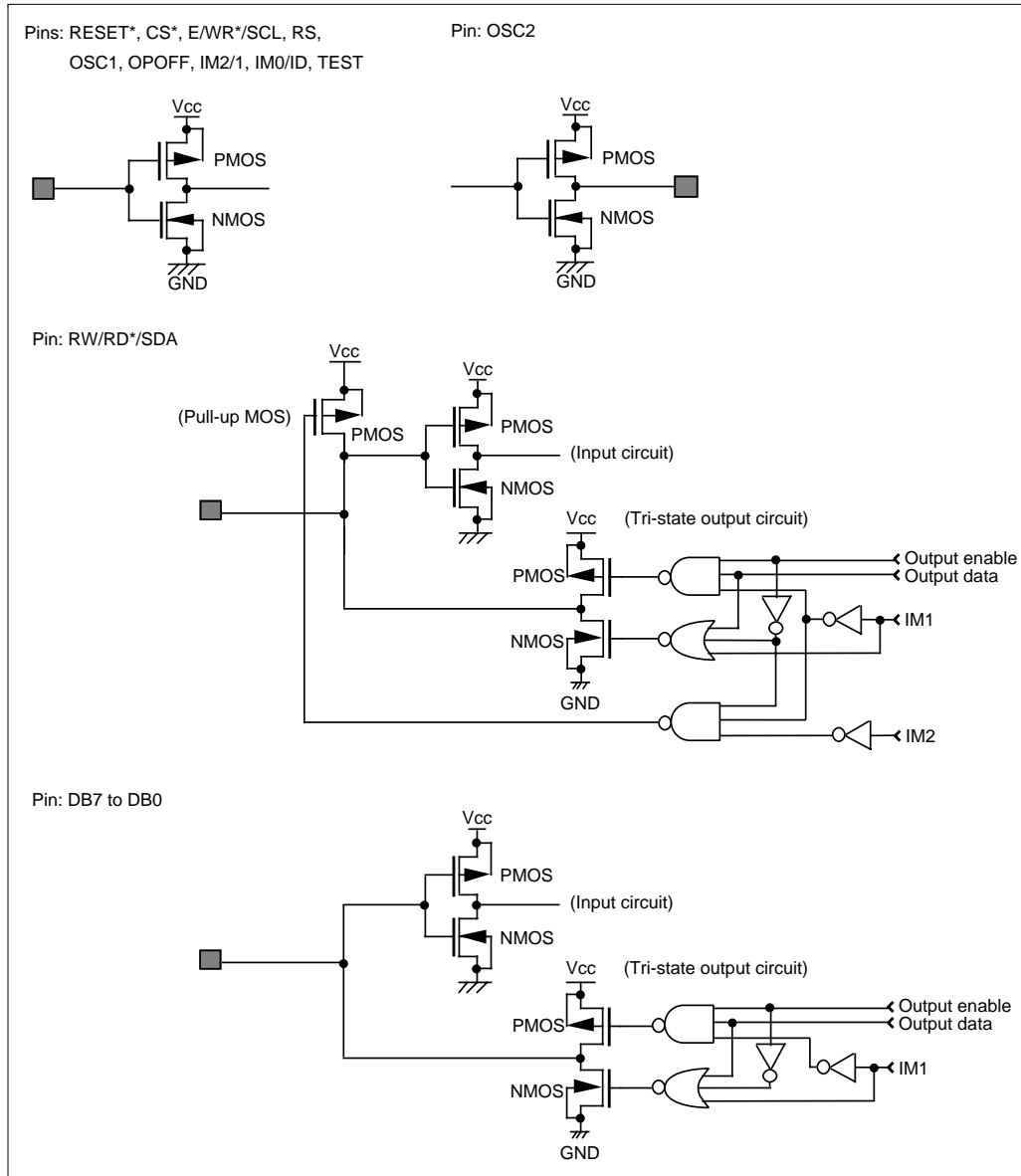

Figure 41 I/O Pin Configuration

HD66740

3. The TEST pin must be grounded and the IM2/1, IM0/ID, and OPOFF pins must be grounded or connected to Vcc.
4. Corresponds to the high output for clock-synchronized serial interface.
5. Applies to the resistor value (RCOM) between power supply pins V1OUT, V2OUT, V5OUT, GND and common signal pins, and resistor value (RSEG) between power supply pins V1OUT, V3OUT, V4OUT, GND and segment signal pins, when current Id is flown through all driver output pins.
6. This excludes the current flowing through pull-up MOSs and output drive MOSs.
7. This excludes the current flowing through the input/output units. The input level must be fixed high or low because through current increases if the CMOS input is left floating.
8. The following shows the relationship between the operation frequency (fosc) and current consumption (Icc) (figure 42).

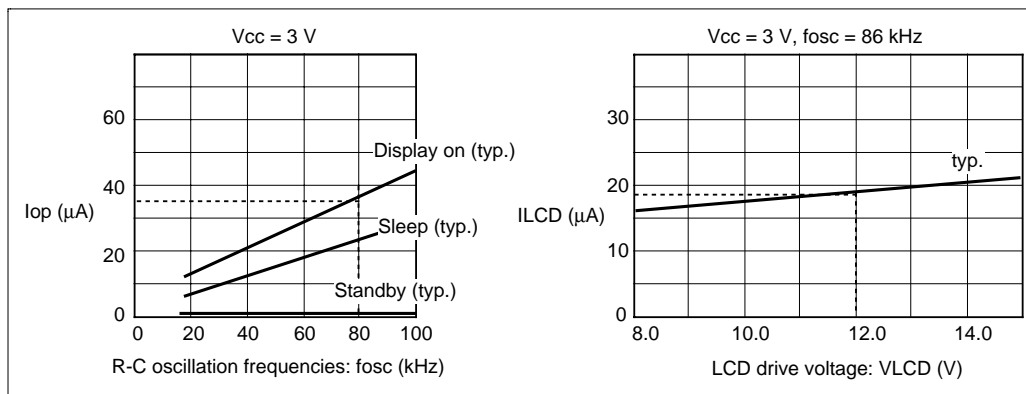

Figure 42 Relationship between the Operation Frequency and Current Consumption

9. Each COM and SEG output voltage is within ± 0.15 V of the LCD voltage (Vcc, V1, V2, V3, V4, V5) when there is no load.
10. Applies to the external clock input (figure 43).

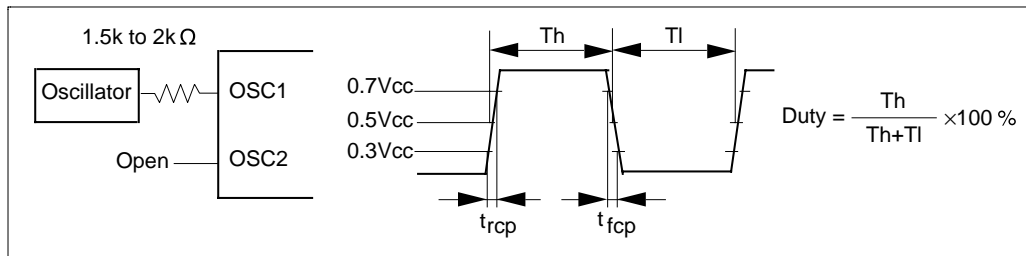

Figure 43 External Clock Supply

HITACHI

11. Applies to the internal oscillator operations using external oscillation resistor Rf (figure 44 and table 28).

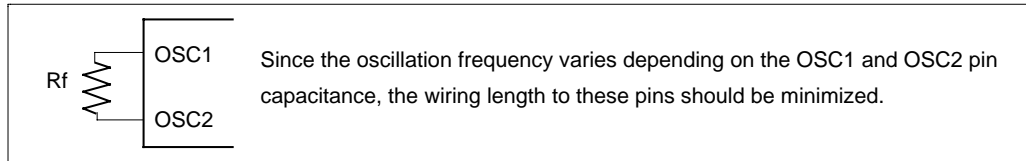

Figure 44 Internal Oscillation

Table 28 External Resistance Value and R-C Oscillation Frequency (Referential Data)

External Resistance (Rf)	R-C Oscillation Frequency: fosc			
	Vcc = 1.8 V	Vcc = 2.2 V	Vcc = 3.0 V	Vcc = 3.6 V
200 kΩ	89 kHz	103kHz	115 kHz	121 kHz
270 kΩ	70 kHz	80 kHz	88 kHz	92 kHz
300 kΩ	65 kHz	73 kHz	80 kHz	83 kHz
330 kΩ	60 kHz	68 kHz	74 kHz	77 kHz
360 kΩ	55 kHz	62 kHz	68 kHz	71 kHz
390 kΩ	52 kHz	58 kHz	64 kHz	66 kHz
430 kΩ	48 kHz	53 kHz	58 kHz	60 kHz
470 kΩ	44 kHz	48 kHz	52 kHz	54 kHz

12. Booster characteristics test circuits are shown in figure 45.

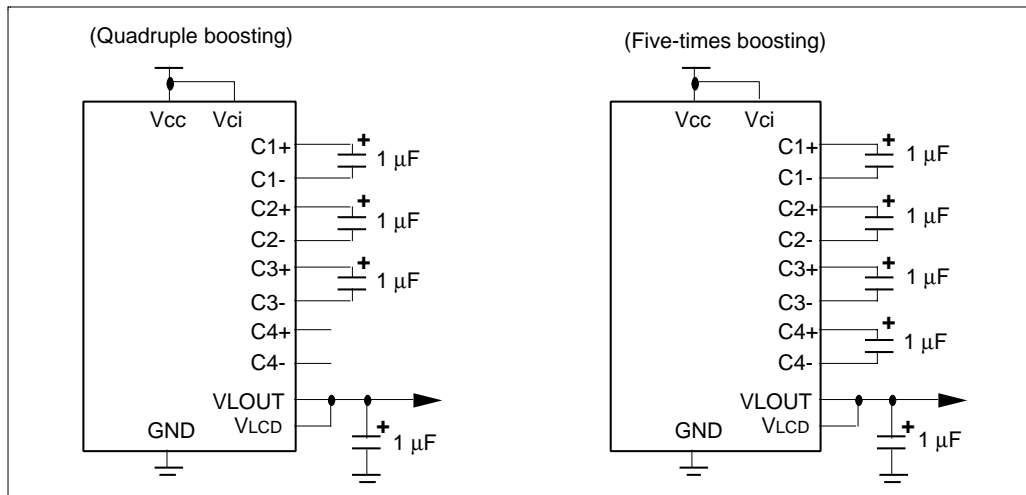

Figure 45 Booster

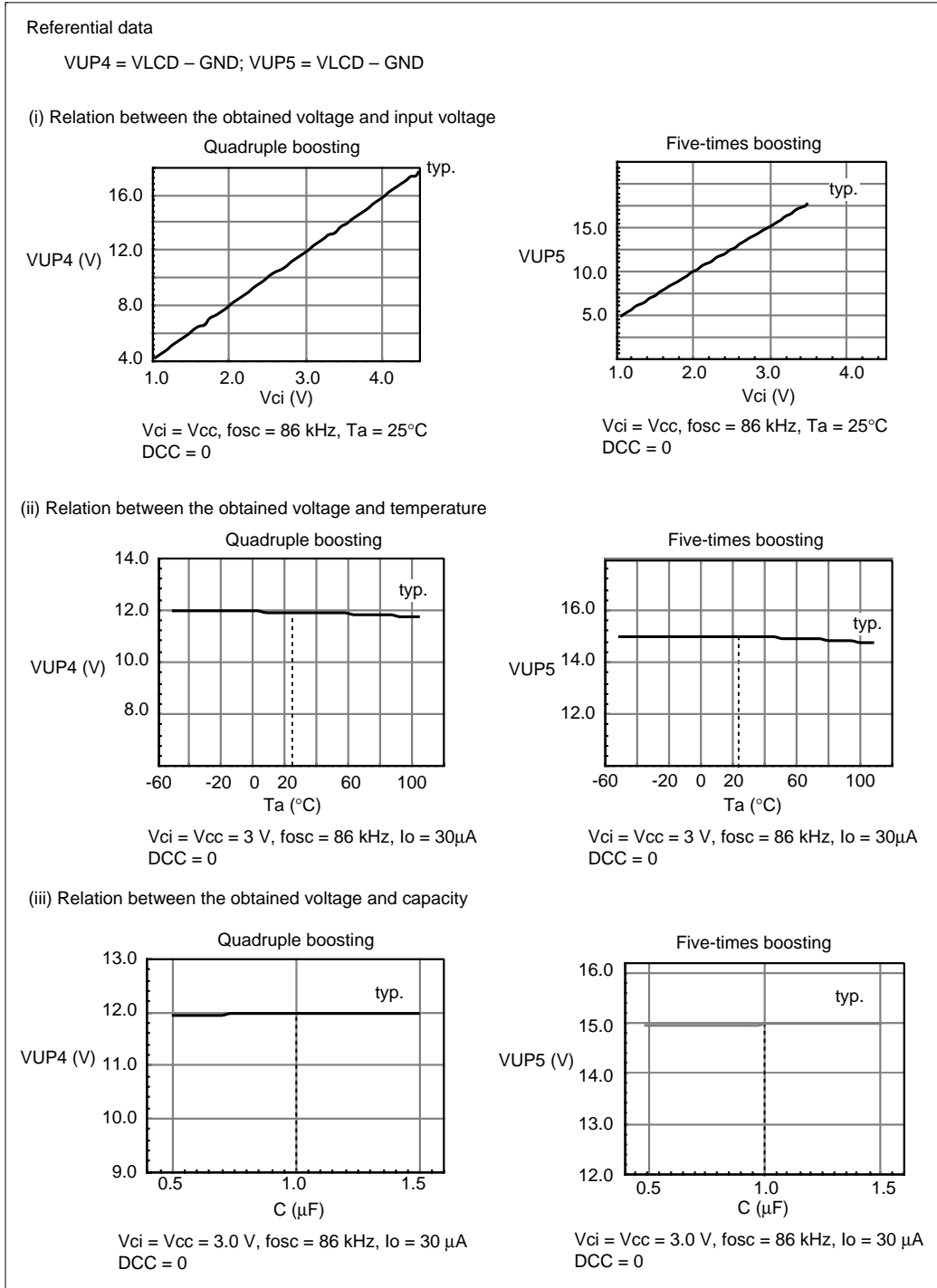

Figure 45 Booster (cont)

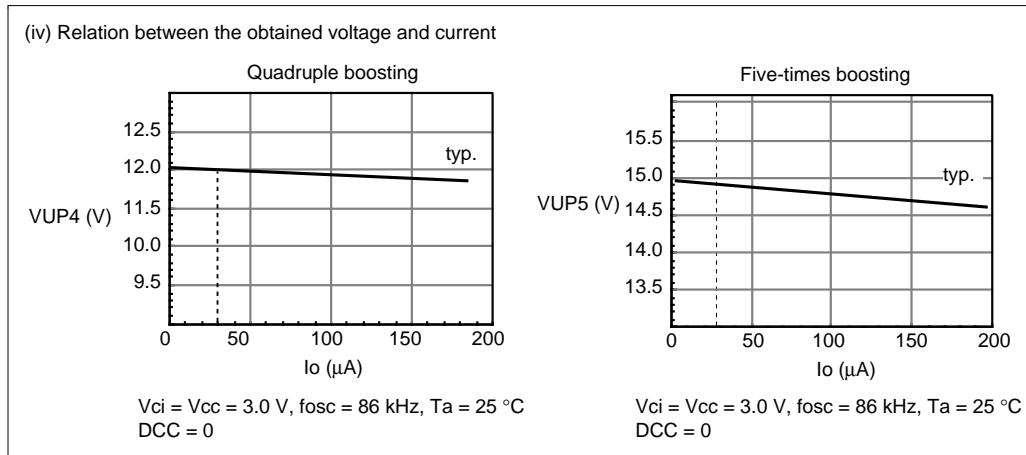

Figure 45 Booster (cont)

Load Circuits

AC Characteristics Test Load Circuits

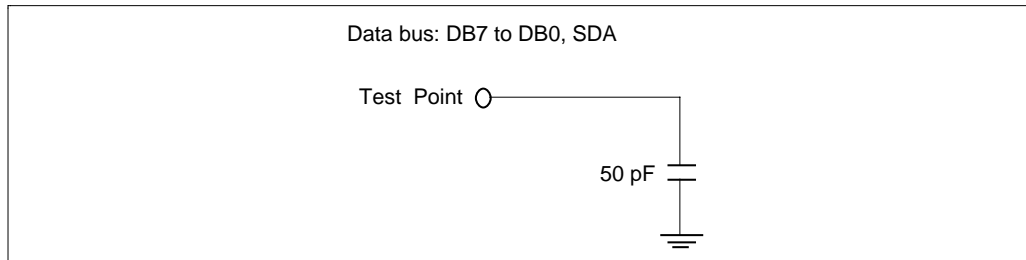

Figure 46 Load Circuit

Timing Characteristics

68-system Bus Operation

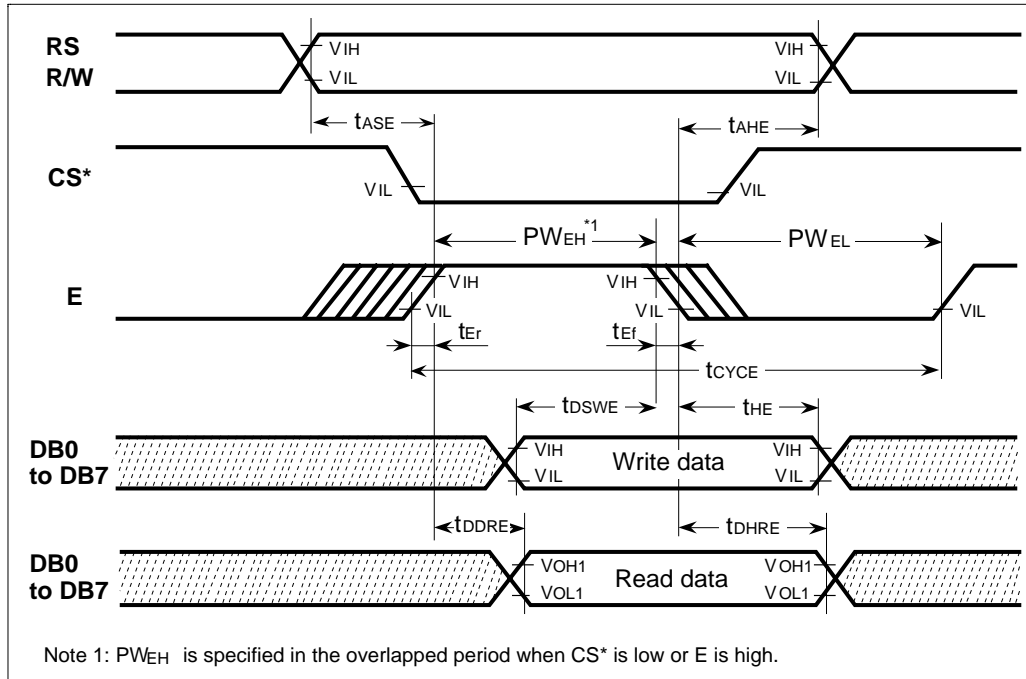

Figure 47 68-system Bus Timing

80-system Bus Operation

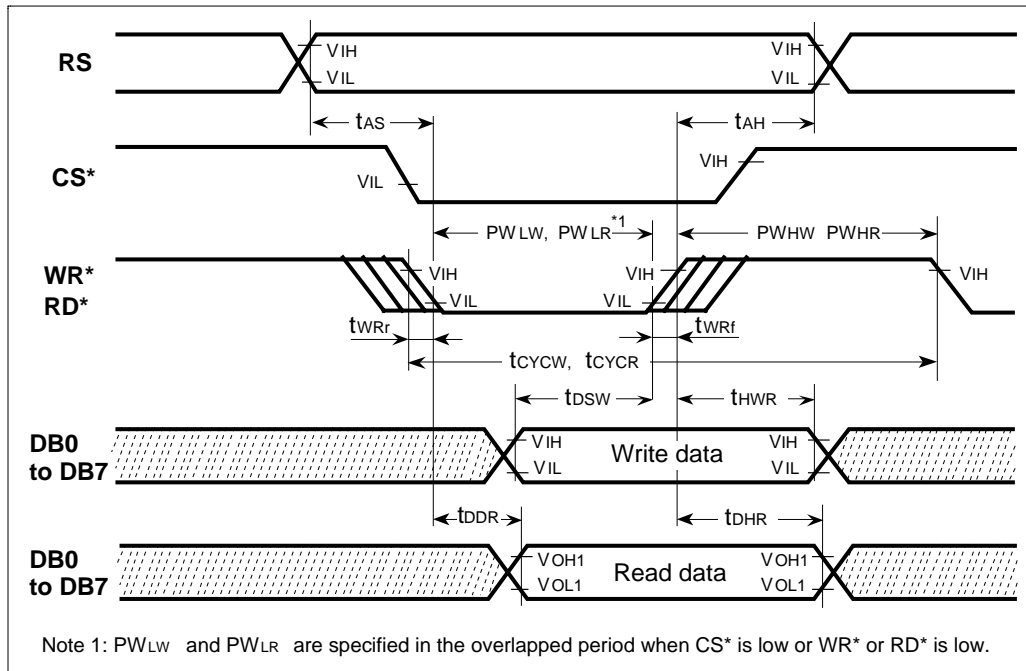

Figure 48 80-system Bus Timing

HD66740

Clock-synchronized Serial Operation

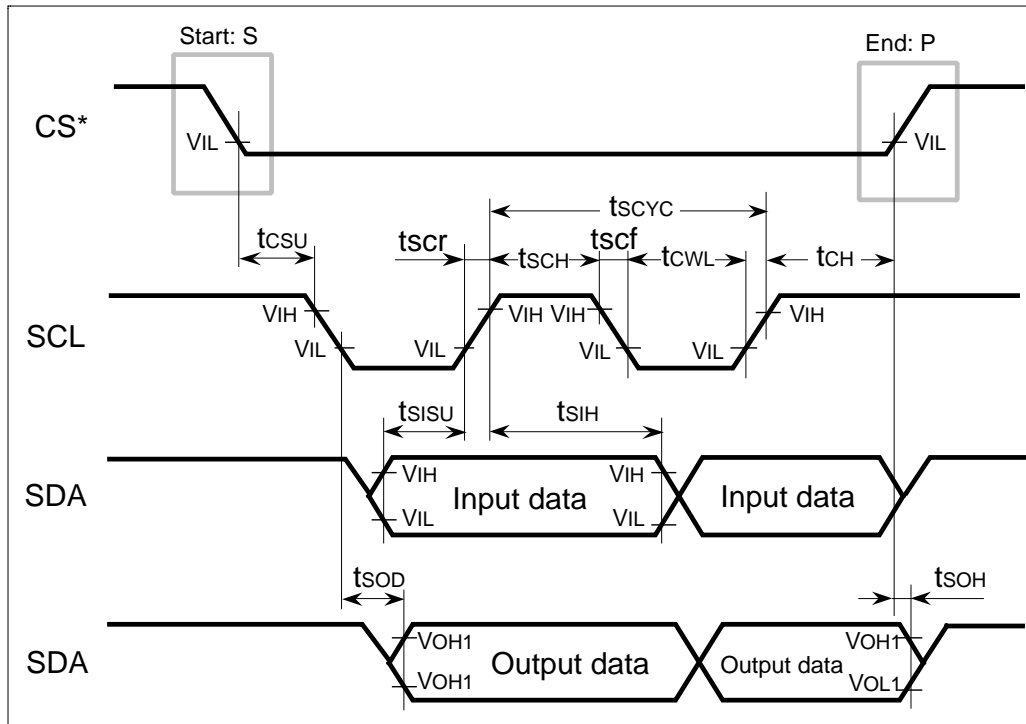

Figure 49 Clock-synchronized Serial Interface Timing

Reset Operation

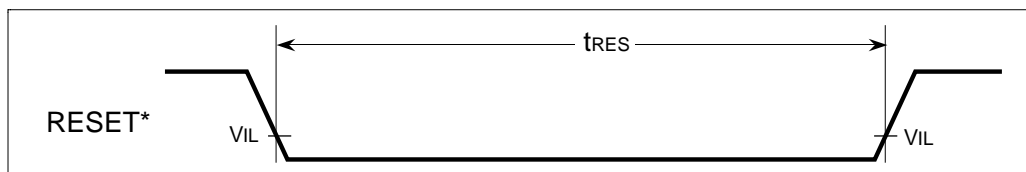

Figure 50 Reset Timing

HITACHI

I2C Bus Operation

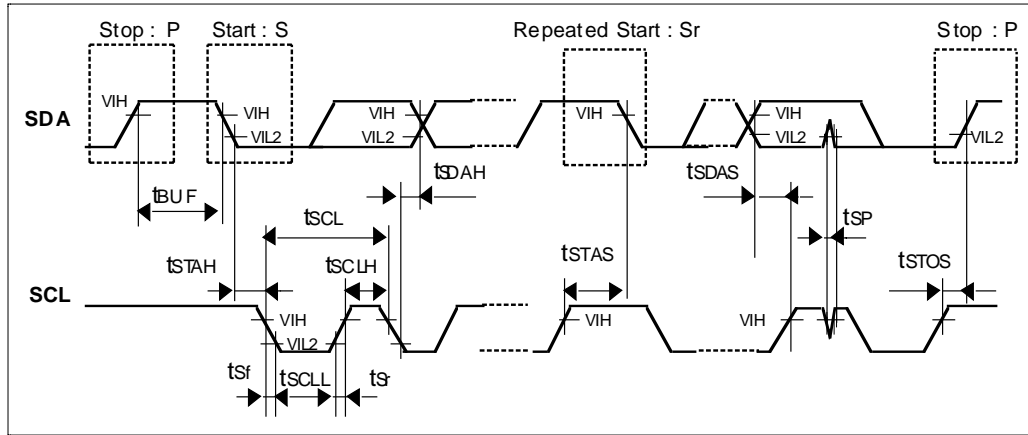

Figure 51 I2C bus Interface Timing

Power-on/off Sequence

To prevent pulse lighting of LCD screens at power-on/off, the power-on/off sequence is activated as shown below. However, since the sequence depends on LCD materials to be used, confirm the conditions by using your own system.

Power-on Sequence

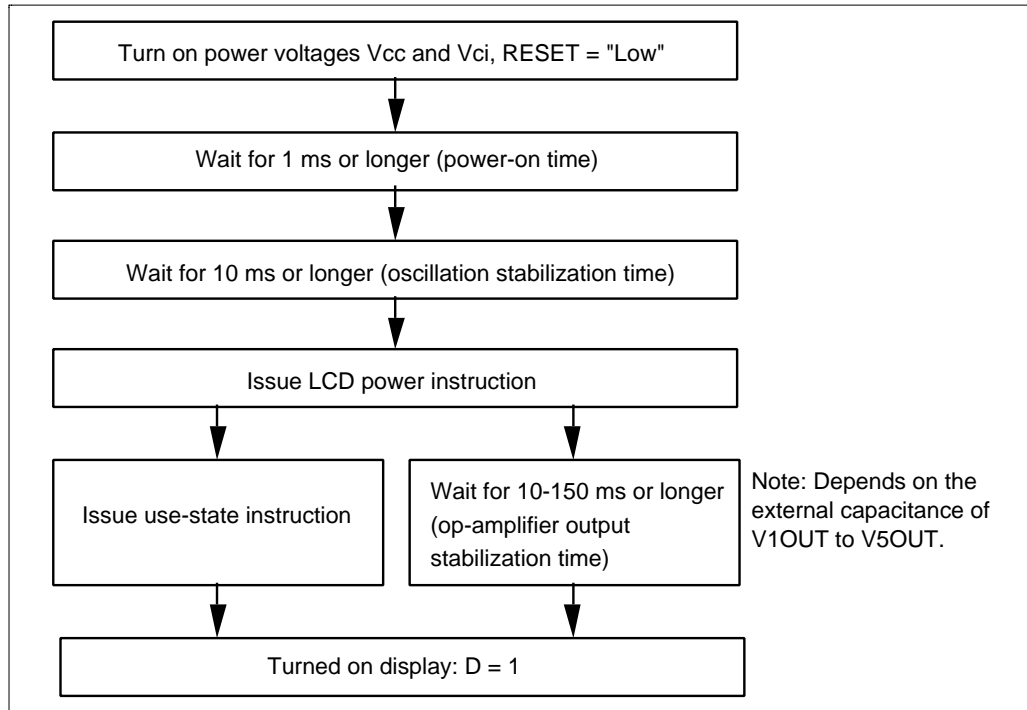

Figure 52 Power-on Sequence

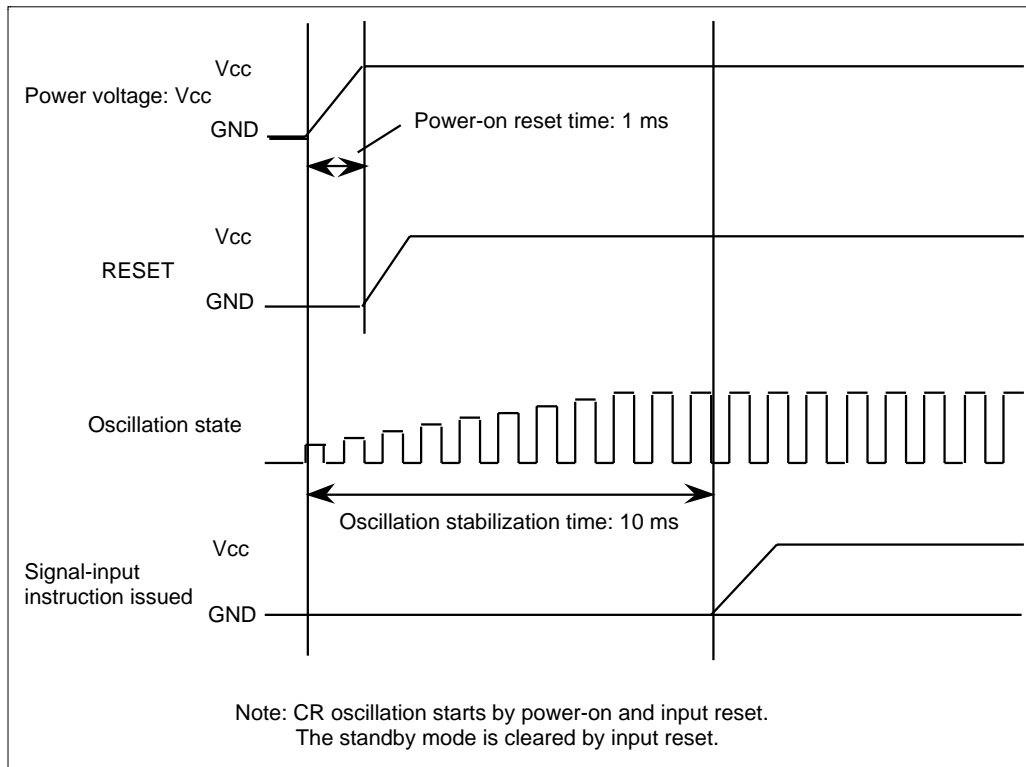
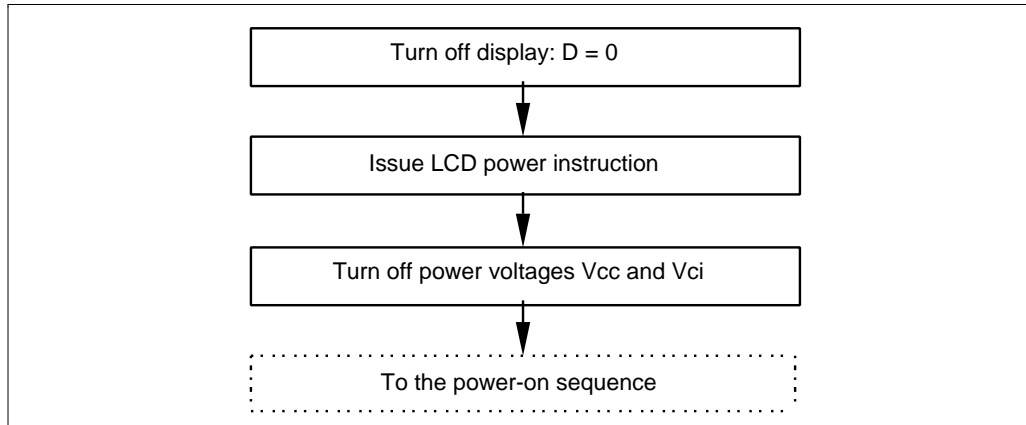
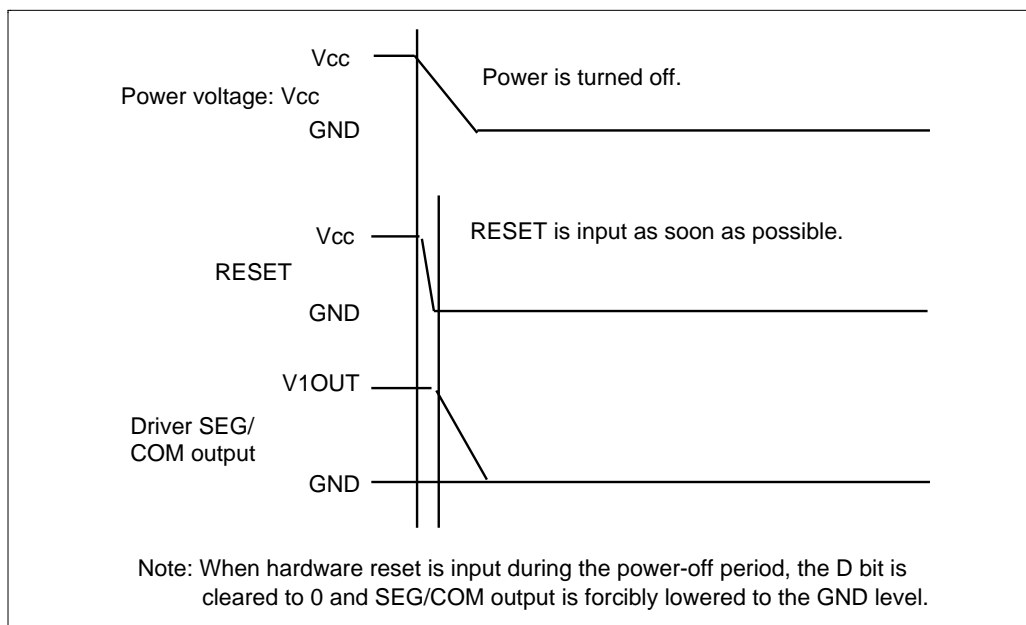

Figure 53 Power-on Timing

Power-off Sequence**Figure 54 Power-off Sequence****Figure 55 Power-off Timing**

Modification history**Revision 0.1 (Feb. 15. 2000)**

- First release

Revision 0.2 (5. May. 2000)

- Change pad pitch from 60um to 50um.
- Added LCD-Driving-Pattern Control instruction

Revision 0.3 (1. July. 2000)

- Added pad arrangement figure and coordinate table
- Change figure 41 (remove pull-up MOS from DB7 to DB0)

Revision 0.4 (September. 2000)

- Added RS pin explanation when serial interface mode is used.
- Added standard TCP (TB0) drawing.

Revision 0.5 (November. 2000)

- Remove cursor display related explanations.
- Remove character and super-imposed display related explanations.

Revision 0.6 (January. 2001)

- Support 1.8V low voltage operation.
- Corrected corner PAD number (p6).
- Added VTEST usage (p48) and operational amplifier usage (p49).
- Changed R-C Oscillation Frequency of Table 28 (p83).
- Added I2C interface (HCD66740WBP, HD66740WTB0).

Revision 0.7 (January. 2001)

- Added power on/off sequence.

When using this document, keep the following in mind:

1. This document may, wholly or partially, be subject to change without notice.
2. All right reserved: No one is permitted to reproduce or duplicated, in any form, the whole or part of this document without Hitachi's permission.
3. Hitachi will not be held responsible for any damage to the user that may result from accidents or any other reasons during operation of the user's unit according to this document.
4. Circuitry and other examples described herein are meant merely to indicate the characteristics and performance of Hitachi's semiconductor products. Hitachi assumes no responsibility for any intellectual property claims or other problems that may result from applications based on the examples described herein.
5. No license is granted by implication or otherwise under any patents or other rights of any third party of Hitachi, Ltd.
6. **MEDICAL APPLICATIONS:** Hitachi's products are not authorized for use in **MEDICAL APPLICATIONS** without the written consent of the appropriate officer of Hitachi's sales company. Such use includes, but is not limited to use in life support systems. Buyers of Hitachi's products are requested to notify the relevant Hitachi sales offices when planning to use the products in **MEDICAL APPLICATIONS**.

HITACHI

