



## Dual N-Channel 30-V (D-S) MOSFET with Schottky Diode

PRODUCT SUMMARY			
	V <sub>DS</sub> (V)	r <sub>DS(on)</sub> (Ω)	I <sub>D</sub> (A)
Channel-1	30	0.022 @ V <sub>GS</sub> = 10 V	6.3
		0.030 @ V <sub>GS</sub> = 4.5 V	5.4
Channel-2		0.013 @ V <sub>GS</sub> = 10 V	10
		0.0185 @ V <sub>GS</sub> = 4.5 V	8.6

SCHOTTKY PRODUCT SUMMARY		
V <sub>DS</sub> (V)	V <sub>SD</sub> (V) Diode Forward Voltage	I <sub>F</sub> (A)
30	0.50 V @ 1.0 A	2.0

### FEATURES

- LITTLE FOOT® Plus Power MOSFET
- 100% R<sub>g</sub> Tested

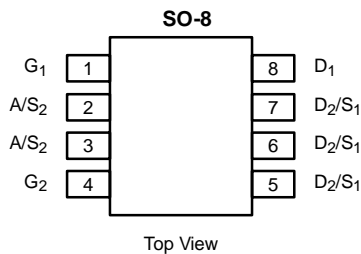

Ordering Information: Si4816DY  
Si4816DY-T1 (with Tape and Reel)  
Si4816DY—E3 (Lead (Pb)-Free)  
Si4816DY-T1—E3 (Lead (Pb)-Free with Tape and Reel)

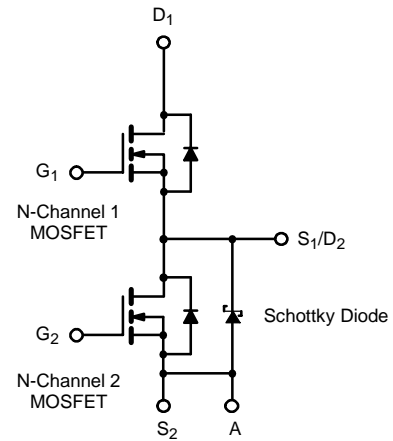

ABSOLUTE MAXIMUM RATINGS (T <sub>A</sub> = 25°C UNLESS OTHERWISE NOTED)							
Parameter	Symbol	Channel-1		Channel-2		Unit	
		10 secs	Steady State	10 secs	Steady State		
Drain-Source Voltage	V <sub>DS</sub>	30				V	
Gate-Source Voltage	V <sub>GS</sub>	20					
Continuous Drain Current (T <sub>J</sub> = 150°C) <sup>a</sup>	I <sub>D</sub>	T <sub>A</sub> = 25°C	6.3	5.3	10	7.7	A
		T <sub>A</sub> = 70°C	5.4	4.2	8.2	6.2	
Pulsed Drain Current	I <sub>DM</sub>	30		40			
Continuous Source Current (Diode Conduction) <sup>a</sup>	I <sub>S</sub>	1.3	0.9	2.2	1.15		
Avalanche Current <sup>b</sup>	I <sub>AS</sub>	12		25		mJ	
		E <sub>AS</sub>		31.25			
Single Pulse Avalanche Energy <sup>b</sup>		7.2					
Maximum Power Dissipation <sup>a</sup>	P <sub>D</sub>	T <sub>A</sub> = 25°C	1.4	1.0	2.4	1.25	W
		T <sub>A</sub> = 70°C	0.9	0.64	1.5	0.8	
Operating Junction and Storage Temperature Range	T <sub>J</sub> , T <sub>stg</sub>	-55 to 150				°C	

THERMAL RESISTANCE RATINGS									
Parameter	Symbol	Channel-1		Channel-2		Schottky		Unit	
		Typ	Max	Typ	Max	Typ	Max		
Maximum Junction-to-Ambient <sup>a</sup>	R <sub>thJA</sub>	t ≤ 10 sec	72	90	43	53	48	60	°C/W
		Steady-State	100	125	82	100	80	100	
Maximum Junction-to-Foot (Drain)	R <sub>thJC</sub>	51	63	25	30	28	35		

**Notes**

- a. Surface Mounted on 1" x 1" FR4 Board.  
b. Starting date code W46BAA.

MOSFET SPECIFICATIONS ( $T_J = 25^\circ\text{C}$ UNLESS OTHERWISE NOTED)							
Parameter	Symbol	Test Condition	Min	Typ <sup>a</sup>	Max	Unit	
<b>Static</b>							
Gate Threshold Voltage	$V_{GS(th)}$	$V_{DS} = V_{GS}, I_D = 250 \mu\text{A}$	Ch-1	0.8		2	V
			Ch-2	1.0		3	
Gate-Body Leakage	$I_{GSS}$	$V_{DS} = 0 \text{ V}, V_{GS} = 20 \text{ V}$	Ch-1			100	nA
			Ch-2			100	
Zero Gate Voltage Drain Current	$I_{DSS}$	$V_{DS} = 30 \text{ V}, V_{GS} = 0 \text{ V}$	Ch-1			1	$\mu\text{A}$
			Ch-2			100	
		$V_{DS} = 30 \text{ V}, V_{GS} = 0 \text{ V}, T_J = 85^\circ\text{C}$	Ch-1			15	
			Ch-2			2000	
On-State Drain Current <sup>b</sup>	$I_{D(on)}$	$V_{DS} = 5 \text{ V}, V_{GS} = 10 \text{ V}$	Ch-1	20			A
			Ch-2	30			
Drain-Source On-State Resistance <sup>b</sup>	$r_{DS(on)}$	$V_{GS} = 10 \text{ V}, I_D = 6.3 \text{ A}$	Ch-1		0.018	0.022	$\Omega$
		$V_{GS} = 10 \text{ V}, I_D = 10 \text{ A}$	Ch-2		0.0105	0.013	
		$V_{GS} = 4.5 \text{ V}, I_D = 5.4 \text{ A}$	Ch-1		0.024	0.030	
		$V_{GS} = 4.5 \text{ V}, I_D = 8.6 \text{ A}$	Ch-2		0.015	0.0185	
Forward Transconductance <sup>b</sup>	$g_{fs}$	$V_{DS} = 15 \text{ V}, I_D = 6.3 \text{ A}$	Ch-1		17		S
		$V_{DS} = 15 \text{ V}, I_D = 10 \text{ A}$	Ch-2		28		
Diode Forward Voltage <sup>b</sup>	$V_{SD}$	$I_S = 1.3 \text{ A}, V_{GS} = 0 \text{ V}$	Ch-1		0.7	1.1	V
		$I_S = 1 \text{ A}, V_{GS} = 0 \text{ V}$	Ch-2		0.47	0.5	
<b>Dynamic<sup>a</sup></b>							
Total Gate Charge	$Q_g$	Channel-1 $V_{DS} = 15 \text{ V}, V_{GS} = 5 \text{ V}, I_D = 6.3 \text{ A}$	Ch-1		8.0	12	nC
			Ch-2		15	23	
Gate-Source Charge	$Q_{gs}$	Channel-2 $V_{DS} = 15 \text{ V}, V_{GS} = 5 \text{ V}, I_D = -10 \text{ A}$	Ch-1		1.75		nC
Gate-Drain Charge	$Q_{gd}$		Ch-2		5.3		
Gate Resistance	$R_g$		Ch-1	1.5		3.1	$\Omega$
			Ch-2	0.5		2.6	
Turn-On Delay Time	$t_{d(on)}$	Channel-1 $V_{DD} = 15 \text{ V}, R_L = 15 \Omega$ $I_D \cong 1 \text{ A}, V_{GEN} = 10 \text{ V}, R_g = 6 \Omega$	Ch-1		10	20	ns
Rise Time	$t_r$		Ch-2		15	30	
Turn-Off Delay Time	$t_{d(off)}$	Channel-2 $V_{DD} = 15 \text{ V}, R_L = 15 \Omega$ $I_D \cong 1 \text{ A}, V_{GEN} = 10 \text{ V}, R_g = 6 \Omega$	Ch-1		5	10	ns
			Ch-2		5	10	
Fall Time	$t_f$		Ch-1		26	50	ns
			Ch-2		44	80	
Source-Drain Reverse Recovery Time	$t_{rr}$	$I_F = 1.3 \text{ A}, di/dt = 100 \text{ A}/\mu\text{s}$	Ch-1		8	16	ns
		$I_F = 2.2 \text{ A}, di/dt = 100 \mu\text{A}/\mu\text{s}$	Ch-2		12	24	
			Ch-1		30	60	
			Ch-2		32	70	

## Notes

- a. Guaranteed by design, not subject to production testing.  
 b. Pulse test; pulse width  $\leq 300 \mu\text{s}$ , duty cycle  $\leq 2\%$ .

SCHOTTKY SPECIFICATIONS ( $T_J = 25^\circ\text{C}$ UNLESS OTHERWISE NOTED)							
Parameter	Symbol	Test Condition	Min	Typ	Max	Unit	
Forward Voltage Drop	$V_F$	$I_F = 1.0 \text{ A}$		0.47	0.50	V	
		$I_F = 1.0 \text{ A}, T_J = 125^\circ\text{C}$		0.36	0.42		
Maximum Reverse Leakage Current	$I_{rm}$	$V_r = 30 \text{ V}$		0.004	0.100	mA	
		$V_r = 30 \text{ V}, T_J = 100^\circ\text{C}$		0.7	10		
		$V_r = -30 \text{ V}, T_J = 125^\circ\text{C}$		3.0	20		
Junction Capacitance	$C_T$	$V_r = 10 \text{ V}$		50		pF	



**TYPICAL CHARACTERISTICS (25°C UNLESS NOTED) CHANNEL-1**

**Output Characteristics**

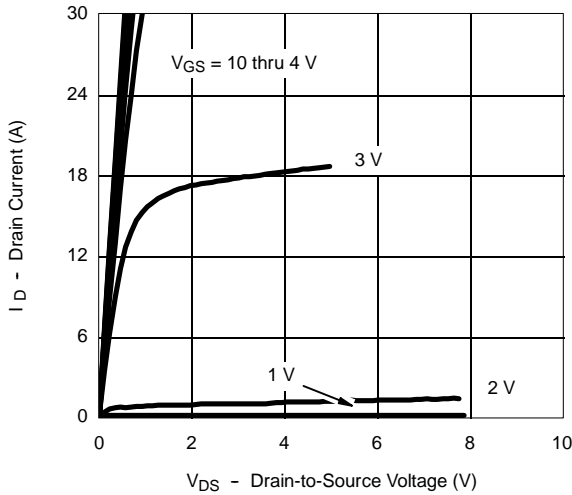

**Transfer Characteristics**

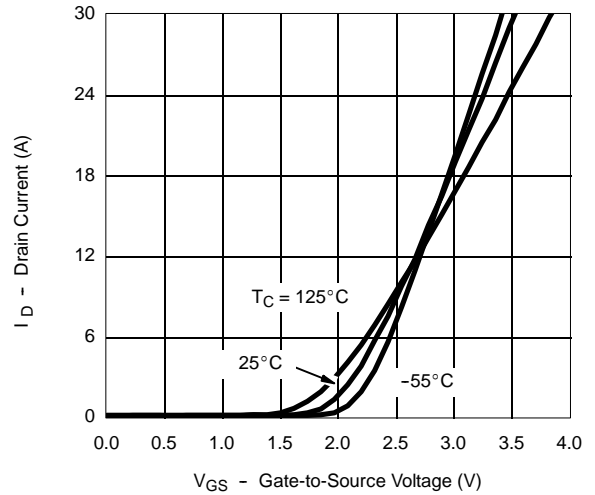

**On-Resistance vs. Drain Current**

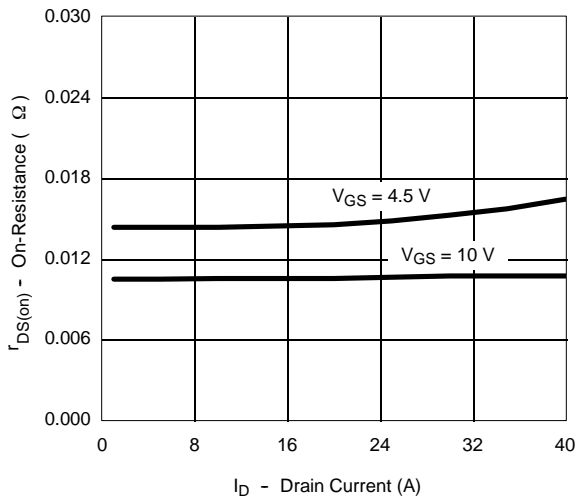

**Capacitance**

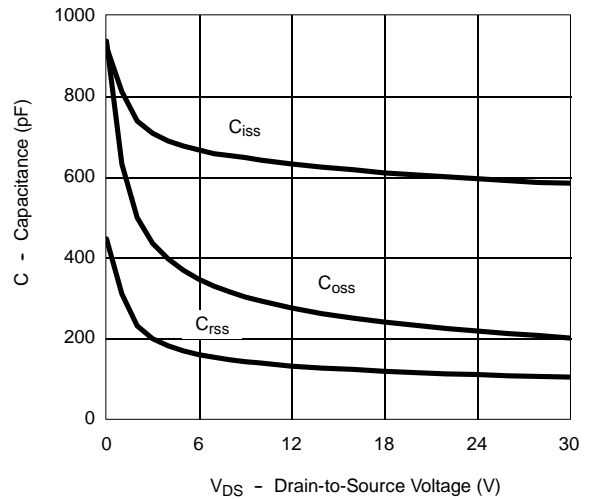

**Gate Charge**

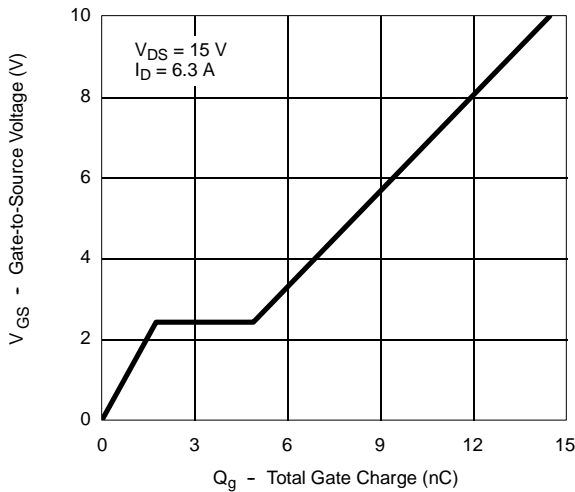

**On-Resistance vs. Junction Temperature**

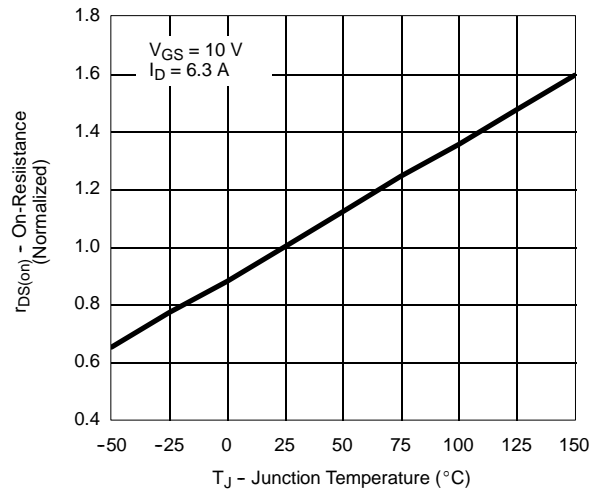

**TYPICAL CHARACTERISTICS (25°C UNLESS NOTED) CHANNEL-1**

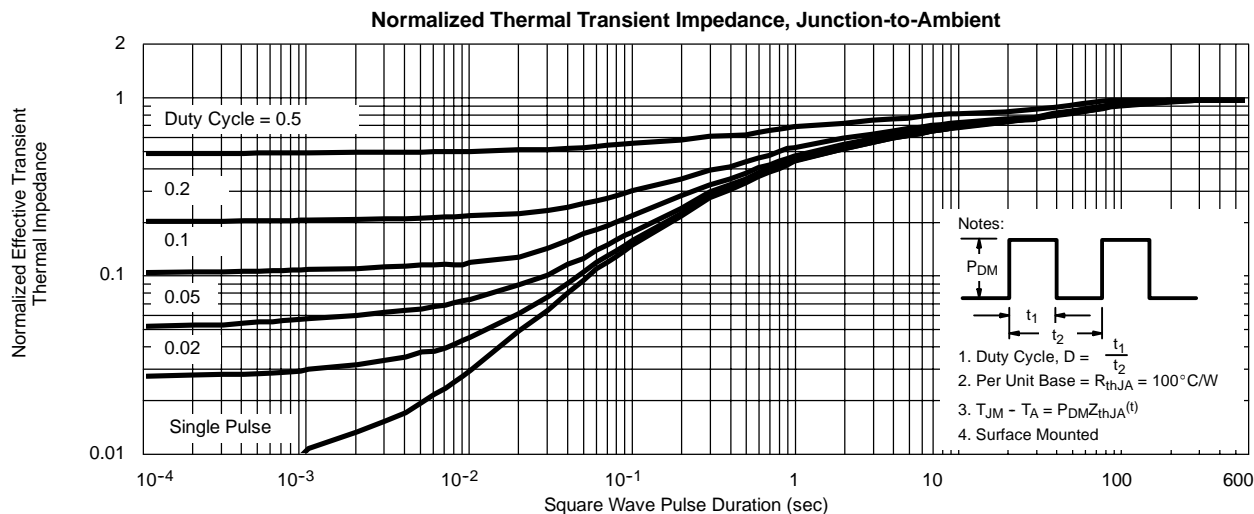
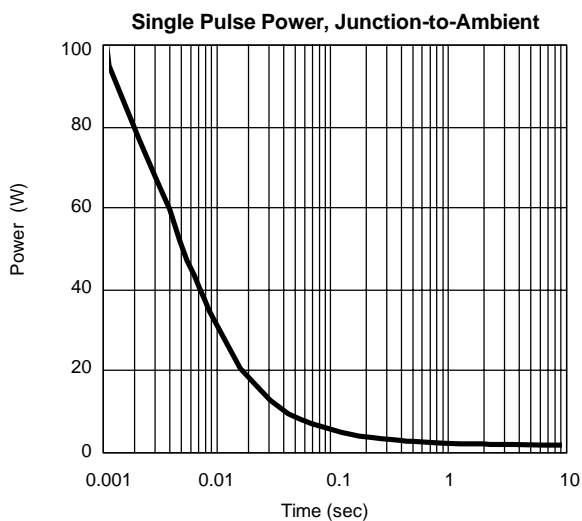
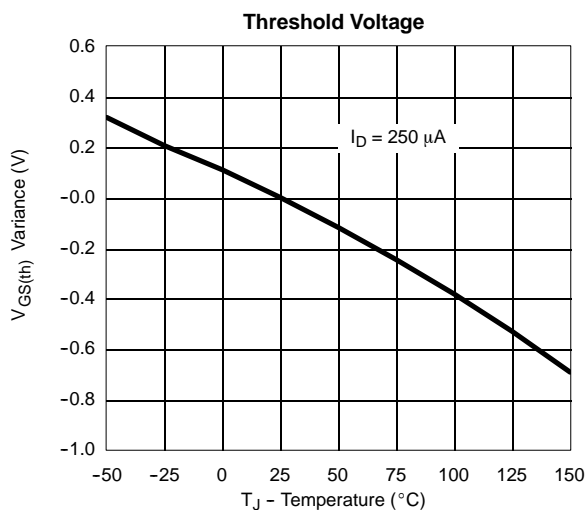
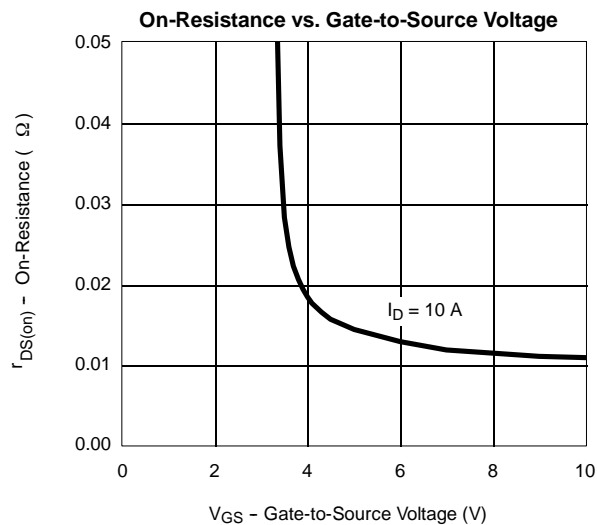
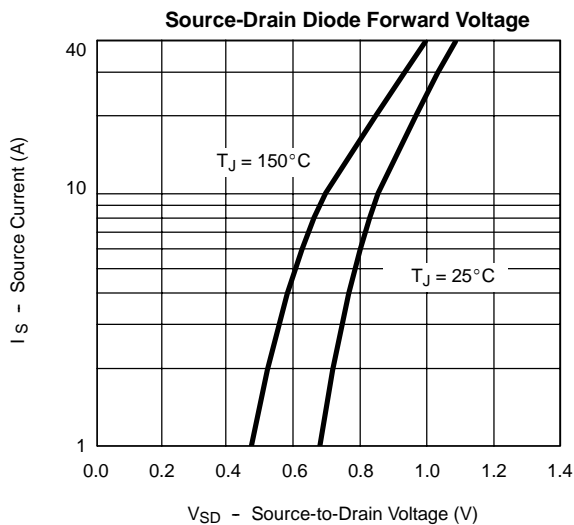



**TYPICAL CHARACTERISTICS (25°C UNLESS NOTED) CHANNEL-1**

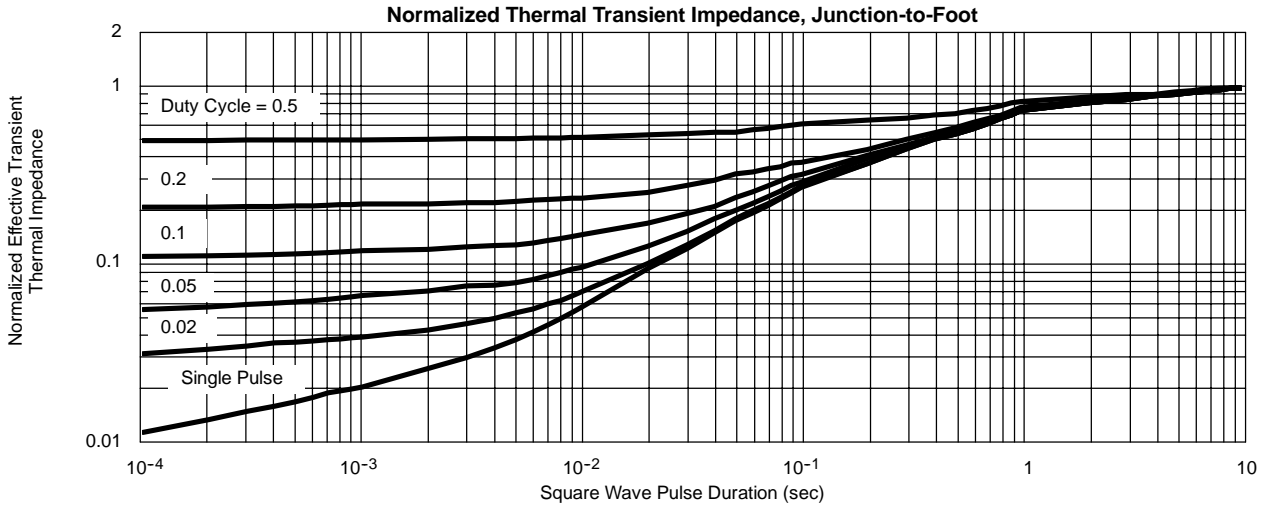

**TYPICAL CHARACTERISTICS (25°C UNLESS NOTED) CHANNEL-2**

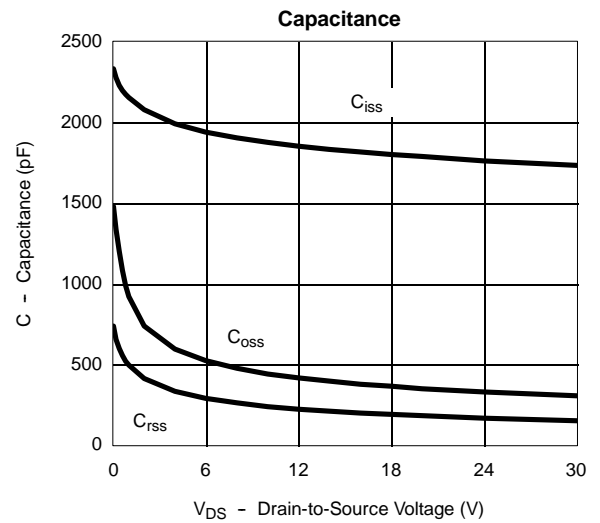
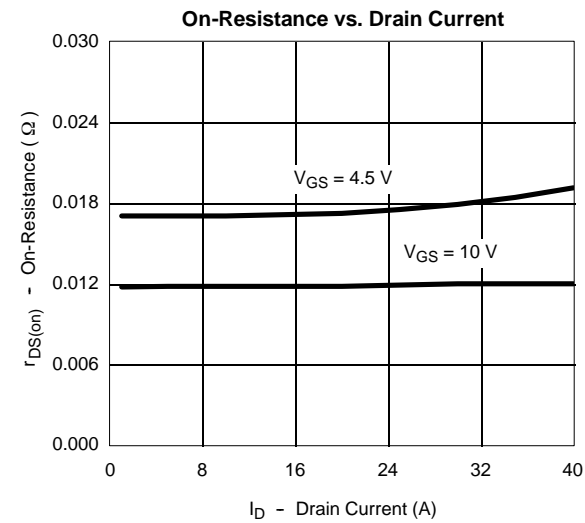
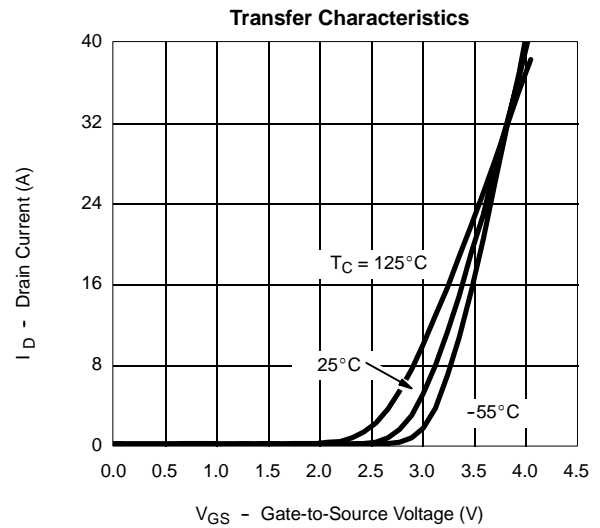
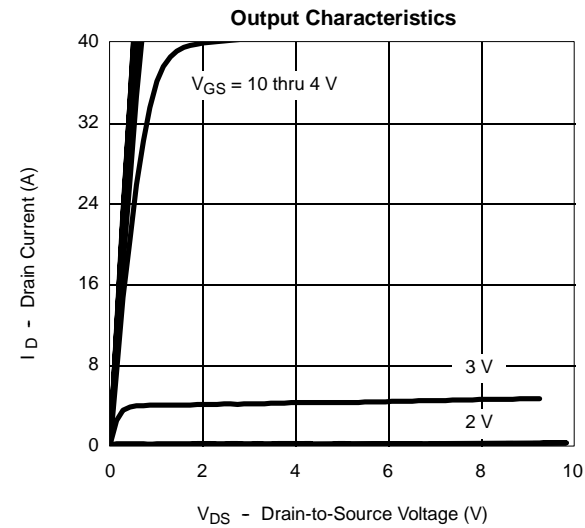

**TYPICAL CHARACTERISTICS (25°C UNLESS NOTED) CHANNEL-2**

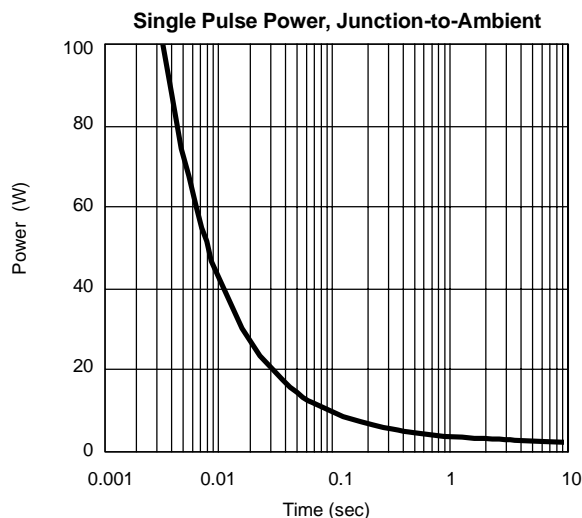
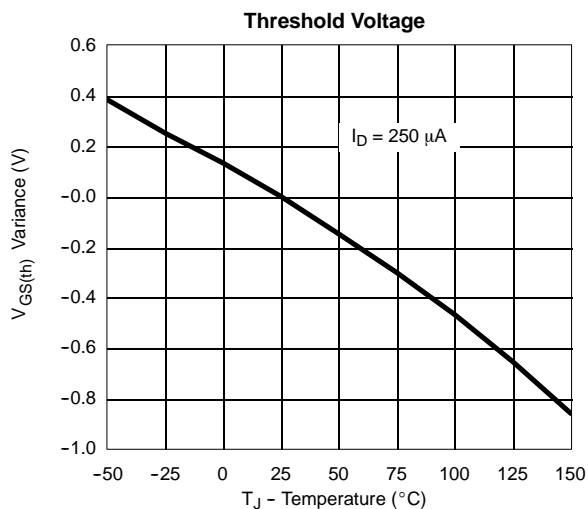
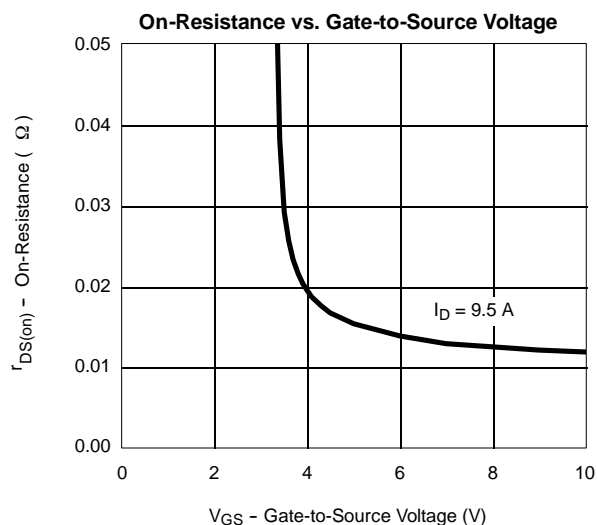
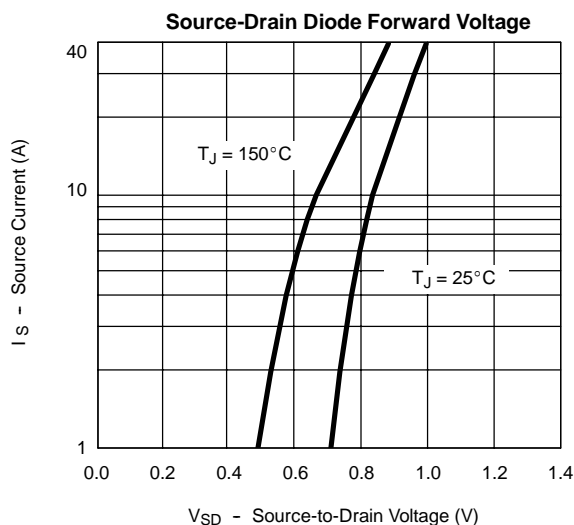
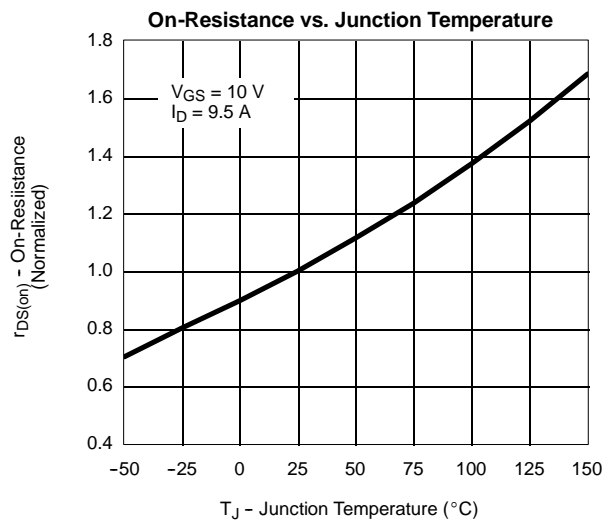
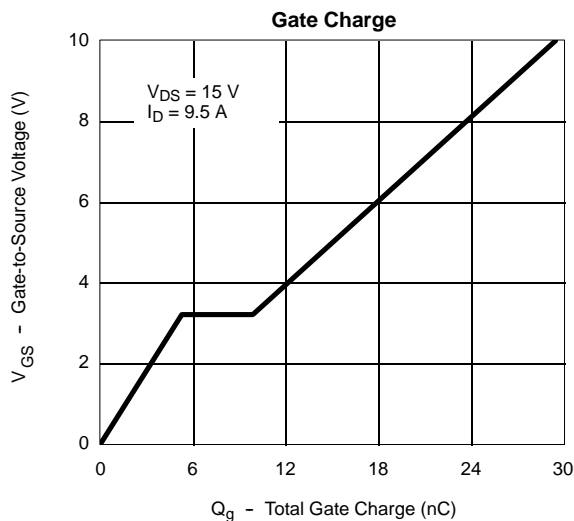

**TYPICAL CHARACTERISTICS (25°C UNLESS NOTED) CHANNEL-2**

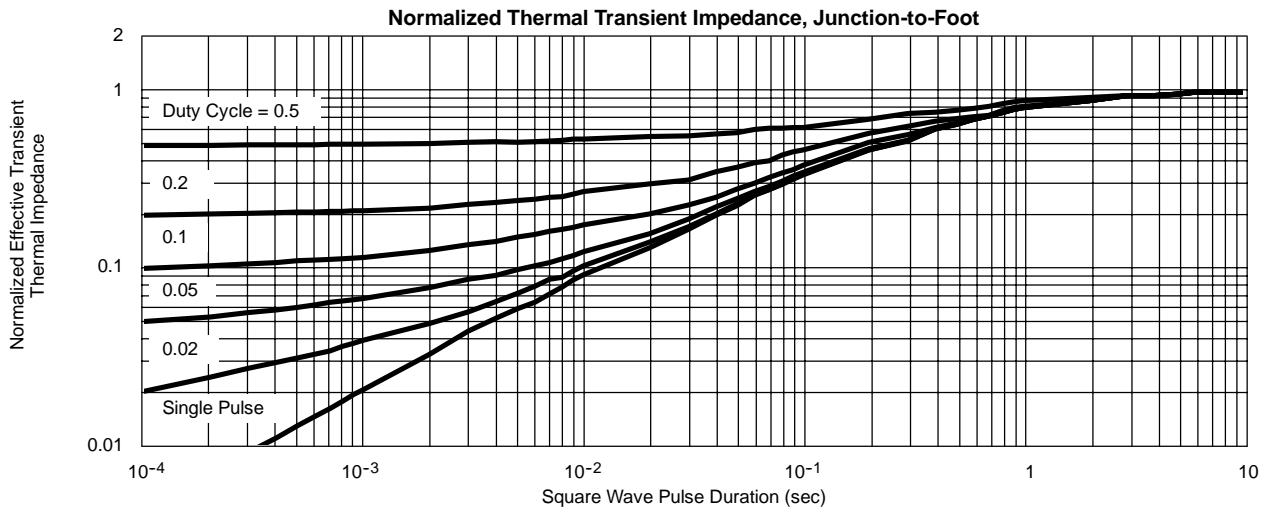
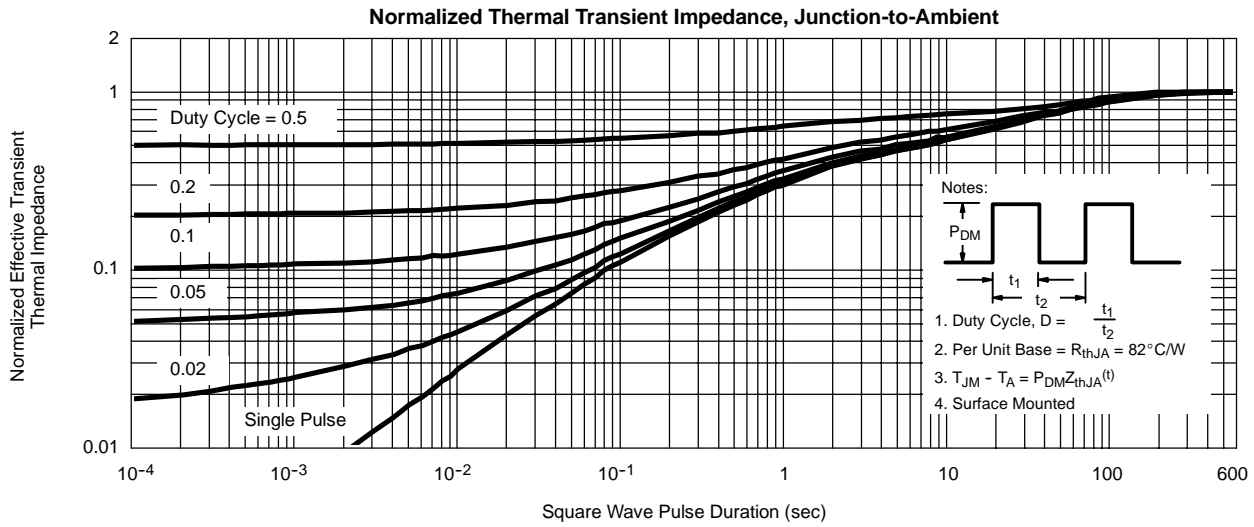

**TYPICAL CHARACTERISTICS (25°C UNLESS NOTED)**

**SCHOTTKY**

