

CXA3537EN

CXA3537TN

While rapid progress continues in portable information equipment such as notebook personal computers, the associated increases in power consumption mean that handling the heat generated has become a critical problem.

To contribute to solving this problem, we proposed a new motor drive system, the DDC system*¹, to reduce fan motor power consumption, and developed the CXA3537EN/TN, which adopts this system.

We showed experimentally that this drive system improves power consumption by approximately 30% over conventional drive systems.

At the same time, we also proposed a procedure for rapidly responding to the resonant vibration problem by adding a motor speed modification function.

- Single-phase full-wave drive type fan motor drivers
- Maximum output current: 300 mA
- Power-saving drive provided by the DDC (drive duty control) system
- The speed of motor rotation can be changed by tap switching
- Low output saturation voltage for low loss
- Wide operating voltage range: 3.0 to 13.2 V
- FG outputs, thermal protection circuit
- Ultrasmall package (CXA3537EN)

*¹ Patent applied for.

The CXA3537EN and CXA3537TN are single-phase full-wave drive type fan motor drivers.

The CXA3537EN is provided in an ultrasmall 12-pin VSON package, and the CXA3537TN is provided in a 16-pin TSSOP package. The CXA3537TN features isolation of the drive block power supply pins from the IC power supply pins, and provides stable motor rotational speed control.

■ DDC System for Power-saving Drive

While conventional single-phase full-wave drive systems apply drive current regardless of the rotation angle position of the rotor, there are ranges of rotor rotation angle positions where the drive torque generation efficiency with respect to the drive current is good, and there are ranges of rotor rotation angle positions where that efficiency is poor. (See figure 1.) The DDC system does not apply drive current at rotation angles where the drive torque generation efficiency is low, but rather applies drive mainly at rotation angles where the efficiency is high. This allows power consumption to be reduced. (See figure 2.) However, since the average drive torque with the DDC system is lower than that provided by conventional single-phase full-wave drive systems, problems, such as longer fan motor startup times, do appear at low-speed area. The CXA3537EN and CXA3537TN use a conventional drive system that provides higher torque at startup and at low-speed area, and automatically switch to the power-saving DDC system in the vicinity of the fan motor rated speed.

■ The Speed of Motor Rotation can be Changed

The DDC system allows the speed of motor rotation to be changed by changing the drive duty. The CXA3537EN/TN provide two taps to switch the drive duty, and thus one of four speeds can be selected by switching the taps. (See figures 3 and 4.)

■ Low Output Saturation Voltage for Low Loss

The CXA3537EN and CXA3537TN adopt newly-developed low saturation voltage transistors in the output stage. At the same time as compensating for the loss in average drive torque due to the DDC system, this also reduces circuit loss.

■ Ultrasmall package

The CXA3537EN is provided in a VSON (Very Thin Small Outline Non-leaded package) package. It features a mounting size of 2.7 × 3.5 mm and a maximum mounting height of 0.9 mm. Thus this device supports the small circuit boards used with small fan motors. (See figure 5.)

V O I C E

We found that when we adopted the DDC system for use with power consumption 1.2 W small fan motors, power consumption was reduced to 0.8 W. Although the average drive torque provided by the DDC system is lower than that provided by conventional drive system, in our tests, the speed of motor rotation only fell by 6%. That means that the difference of 0.4 W has simply been lost as heat in earlier circuits. This is truly wasteful. I strongly recommend that fan motor manufacturers adopt the CXA3537.



New Products

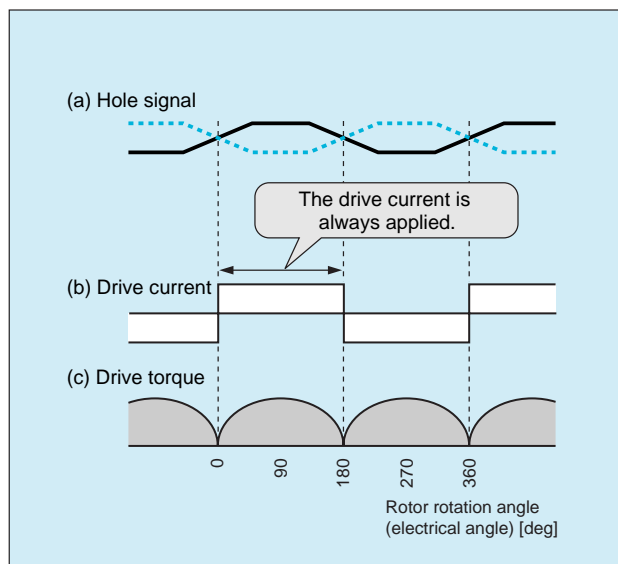

■ Figure 1 Operating Waveforms of a Conventional Single-phase Full-wave Drive

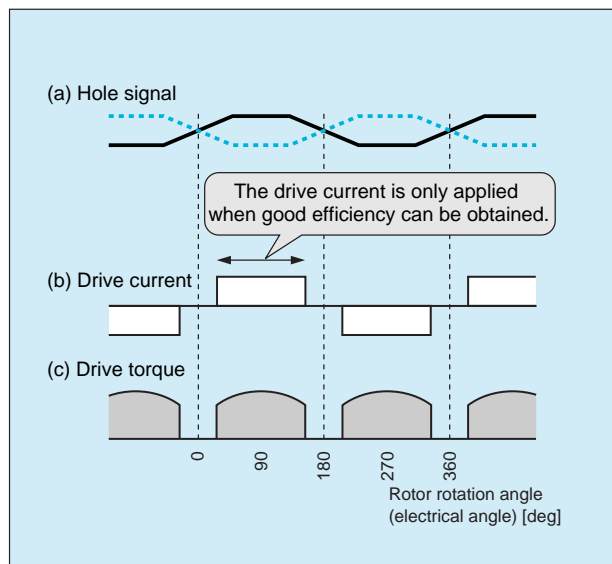

■ Figure 2 Operating Waveforms of a DDC System Drive

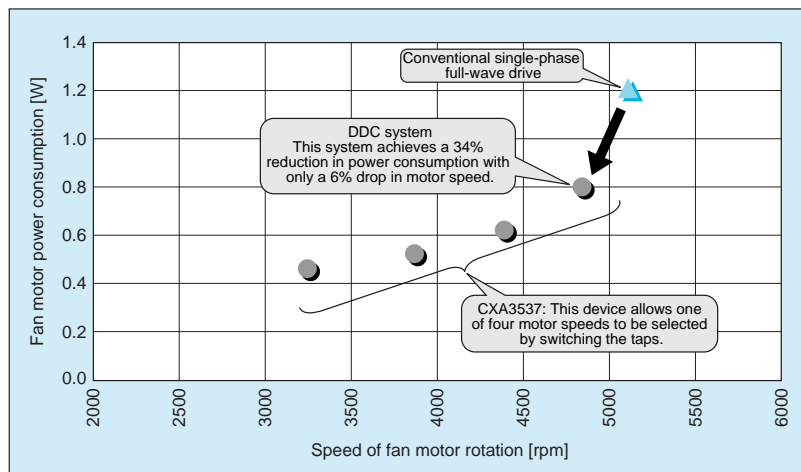

■ Figure 3 Power-saving Effects of a DDC System Drive and Variable-speed Function (Experimentally verified results)

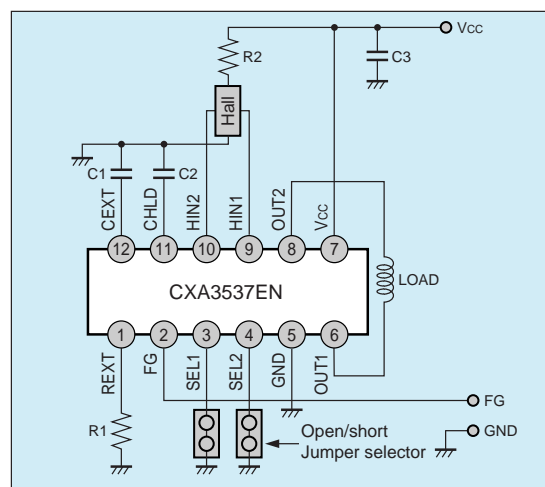

■ Figure 4 CXA3537EN Application Circuit

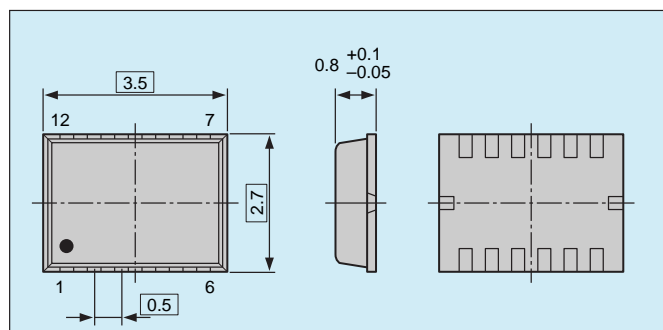

■ Figure 5 CXA3537EN Package Dimensions (Provisional)