

L-band Down Converter IC

For the availability of this product, please contact the sales office.

Description

The CXA3008N-1/-2 is a monolithic IC to down-convert the L-band (1 to 2 GHz) signal for the satellite broadcasting receiver. It has a double-balanced mixer, local oscillator circuit and IF amplifier on chip.

Features

- Balance-type Colpitts oscillator circuit provides a stable and wide range oscillation. Especially, the CXA3008N-1 allows oscillation of up to 2.53 GHz for CS.
- Small leak of the local oscillation signal due to the double-balanced mixer.
- Local oscillator output circuit for PLL.
- Single 5 V power supply operation.
- Low current consumption.  $I_{cc}=55$  mA (typ.)
- 16-pin SSOP package contributes to reduction in set size.

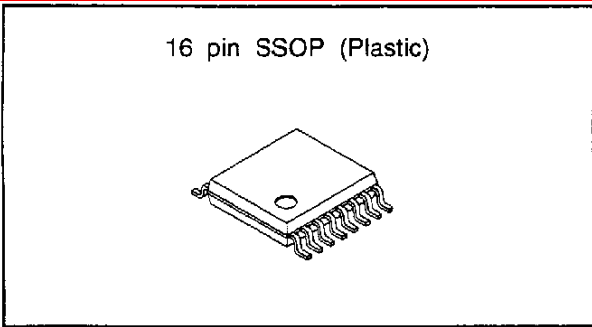

Absolute Maximum Ratings (Ta=25°C)

- Supply voltage  $V_{cc}$  6.5 V
- Storage temperature  $T_{stg}$  -55 to +150 °C
- Allowable power dissipation  $P_D$  625 mW (When mounted on board)

Operating Conditions

- Supply voltage  $V_{cc}$  4.75 to 5.3 V
- Ambient temperature  $T_{opr}$  -20 to 75 °C

Applications

- First IF frequency conversion for BS/CS (CXA3008N-1)
- First IF frequency conversion for BS (CXA3008N-2)

Structure

Bipolar silicon monolithic IC

Block Diagram and Pin Configuration

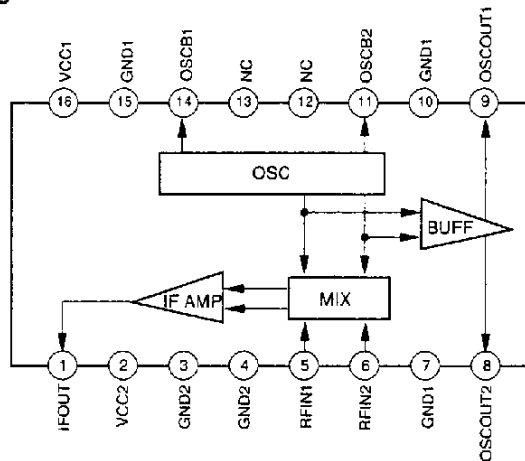

Sony reserves the right to change products and specifications without prior notice. This information does not convey any license by any implication or otherwise under any patents or other right. Application circuits shown, if any, are typical examples illustrating the operation of the devices. Sony cannot assume responsibility for any problems arising out of the use of these circuits.

Pin Description and Equivalent Circuit

Pin No.	Symbol	Typical pin voltage (V)	Equivalent circuit	Description
1	IF OUT	2.6		IF output.
2	VCC2	5.0		IF block power supply.
3	GND2	0		IF block GND.
4	GND2	0		IF block GND.
5	RF IN1	1.5		RF input. Normally, a decoupling capacitor is connected at Pin 5 to GND and Pin 6 is used for input.
6	RF IN2	1.5		
7	GND1	0		RF block GND.
8	OSC OUT2	3.1		Local oscillation output.
9	OSC OUT1	3.1		

Pin No.	Symbol	Typical pin voltage (V)	Equivalent circuit	Description
10	GND1	0		RF block GND.
11	OSC B2	2.4		Oscillator.
12	NC	—		
13	NC	—		
14	OSC B1	2.4		
15	GND1	0		RF block GND.
16	VCC1	5.0		RF block power supply.

**Electrical Characteristics** (Ta=25°C, Vcc=5 V, refer to the Electrical Characteristics Measurement Circuit.)  
CXA3008N-1 (input frequency: 950 to 2050 MHz)

No	Item	Symbol	Measurement conditions	Min.	Typ.	Max.	Unit
1	Current consumption	I <sub>cc</sub>	No signal	44.0	55.0	73.5	mA
2	Conversion gain *1	CG1	f <sub>in</sub> = 950MHz, f <sub>IF</sub> = 480MHz	17	20	24	dB
		CG2	f <sub>in</sub> = 1450MHz, f <sub>IF</sub> = 480MHz	17	20	24.5	dB
		CG3	f <sub>in</sub> = 2050MHz, f <sub>IF</sub> = 480MHz	16	19.5	24.5	dB
3	Noise figure *1, 2	NF1	f <sub>in</sub> = 950MHz, f <sub>IF</sub> = 480MHz		15.5	16.5	dB
		NF2	f <sub>in</sub> = 1450MHz, f <sub>IF</sub> = 480MHz		16.5	17.5	dB
		NF3	f <sub>in</sub> = 2050MHz, f <sub>IF</sub> = 480MHz		17.5	19	dB
4	Local oscillation output	Posc1	f <sub>osc</sub> = 1350 to 1930MHz	-5.5	-2.0		dBm
		Posc2	f <sub>osc</sub> = 1930 to 2200MHz	-6.5	-3.0		dBm
		Posc3	f <sub>osc</sub> = 2200 to 2530MHz	-9.0	-5.0		dBm
5	IF maximum output	Po(sat)	f <sub>IF</sub> = 480MHz	5.5	8.5	11.0	dBm
6	RF pin local oscillation leakage	RFLK1	f <sub>osc</sub> = 1350 to 1930MHz			-18	dBm
		RFLK2	f <sub>osc</sub> = 1930 to 2200MHz			-26	dBm
		RFLK3	f <sub>osc</sub> = 2200 to 2530MHz			-20	dBm
7	IF pin local oscillation leakage	IFLK1	f <sub>osc</sub> = 1350 to 1930MHz			-17	dBm
		IFLK2	f <sub>osc</sub> = 1930 to 2200MHz			-32	dBm
		IFLK3	f <sub>osc</sub> = 2200 to 2530MHz			-28	dBm
8	Third-order intermodulation distortion *1, 3	IM3	P <sub>in</sub> = -25dBm f <sub>in</sub> = 950MHz + 960MHz f <sub>out</sub> = 380MHz + 400MHz S/I of 380MHz and 400MHz		48.0		dB
9	Local oscillation phase noise	CN1	f <sub>osc</sub> =1350MHz, offset 10kHz		74		dBc/Hz
		CN2	f <sub>osc</sub> =1350MHz, offset 100kHz		95		dBc/Hz
10	IF output VSWR	IFVSWR	f = 400MHz		1.2		
11	RF input impedance	r <sub>π</sub>	f = 950MHz		270		Ω
		C <sub>π</sub>			4		pF

\*1) Measured value for untuned inputs.

\*2) Noise figure is uncorrected for image.

\*3) Measure S/I of the desired intermediate frequency (400 MHz) and distortion component (380 MHz) with a spectrum analyzer, assuming input level of the reception frequency to be -25 dBm (when IC input pin is converted for 50Ω).

**Electrical Characteristics** (Ta=25°C, VCC=5 V, refer to the Electrical Characteristics Measurement Circuit.)  
CXA3008N-2 (input frequency: 950 to 1450 MHz)

No	Item	Symbol	Measurement conditions	Min.	Typ.	Max.	Unit
1	Current consumption	Icc	No signal	35.5	55.0	73.5	mA
2	Conversion gain*1	CG1	f <sub>in</sub> = 950MHz, f <sub>IF</sub> = 480MHz	15.5	20	24	dB
		CG2	f <sub>in</sub> = 1450MHz, f <sub>IF</sub> = 480MHz	15.5	20	24.5	dB
3	Noise figure*1, 2	NF1	f <sub>in</sub> = 950MHz, f <sub>IF</sub> = 480MHz		15.5	17.0	dB
		NF2	f <sub>in</sub> = 1450MHz, f <sub>IF</sub> = 480MHz		16.5	18.0	dB
4	Local oscillation output	POSC1	f <sub>osc</sub> = 1350 to 1930MHz	-5.5	-2.0		dBm
5	IF maximum output	Po(sat)	f <sub>IF</sub> = 480MHz	5.5	8.5	11.0	dBm
6	RF pin local oscillation leakage	RFLK1	f <sub>osc</sub> = 1350 to 1930MHz			-18	dBm
7	IF pin local oscillation leakage	IFLK1	f <sub>osc</sub> = 1350 to 1930MHz			-17	dBm
8	Third-order intermodulation distortion*1, 3	IM3	Pin = -25dBm f <sub>in</sub> = 950MHz + 960MHz f <sub>out</sub> = 380MHz + 400MHz S/I of 380MHz and 400MHz		48.0		dB
9	Local oscillation phase noise	CN1	f <sub>osc</sub> =1350MHz, offset 10kHz		74		dBc/Hz
		CN2	f <sub>osc</sub> =1350MHz, offset 100kHz		95		dBc/Hz
10	IF output VSWR	IFVSWR	f = 400MHz		1.2		
11	RF input impedance	r <sub>π</sub>	f = 950MHz		270		Ω
		C <sub>π</sub>			4		pF

\*1) Measured value for untuned inputs.

\*2) Noise figure is uncorrected for image.

\*3) Measure S/I of the desired intermediate frequency (400 MHz) and distortion component (380 MHz) with a spectrum analyzer, assuming input level of the reception frequency to be -25 dBm (when IC input pin is converted for 50Ω).

Electrical Characteristics Measurement Circuit

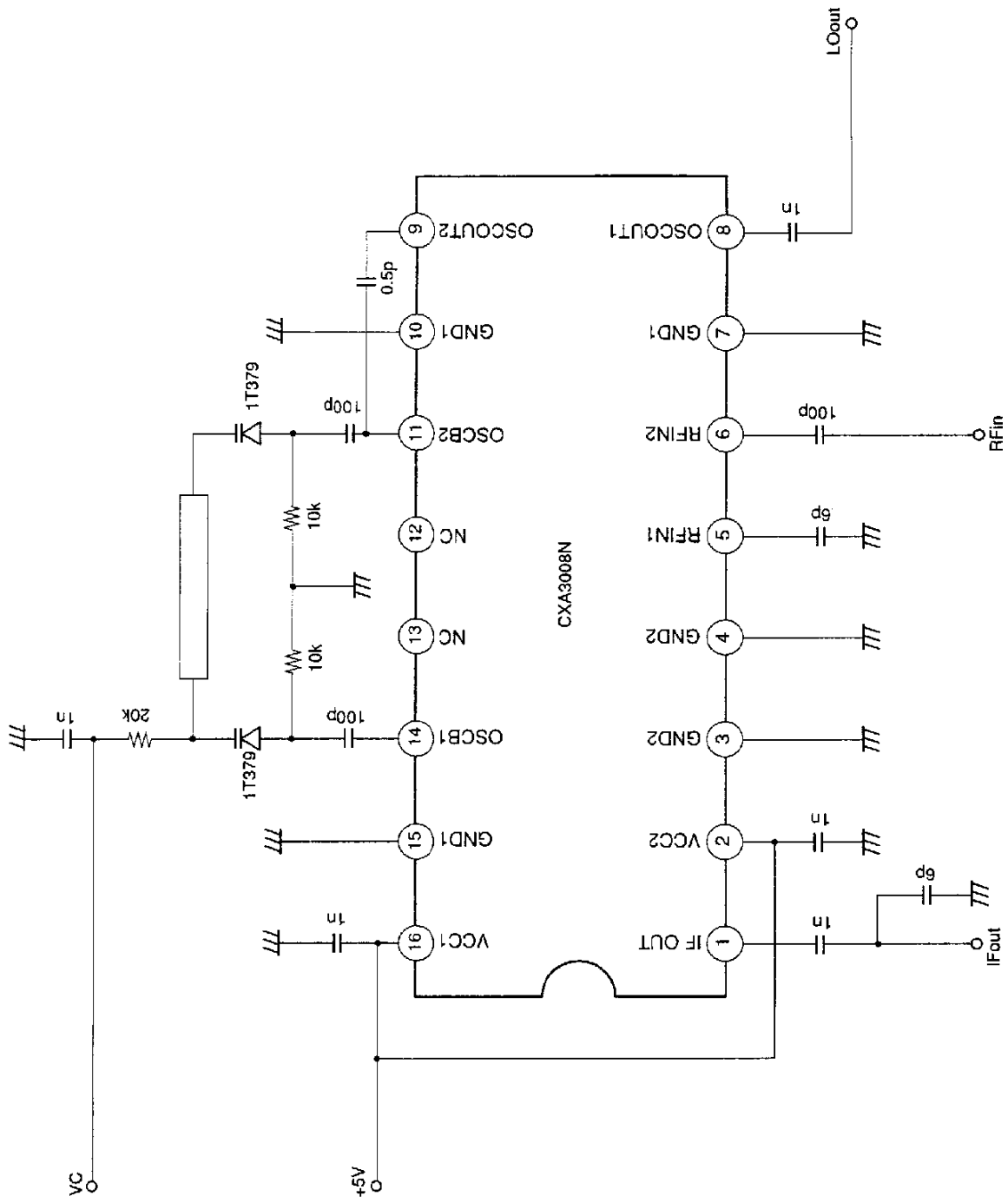

**Description of Operation (Refer to the Electrical Characteristics Measurement Circuit.)**

## 1) Oscillator circuit

The oscillator circuit is formed with two Colpitts oscillators, and oscillation is provided at the differential input via an LC resonance circuit including a varicap diode. This is oscillated only by attaching an LC resonance circuit externally because feedback capacitance, etc. are built in for oscillation.

## 2) Mixer circuit

This is a double-balance mixer having small leak of local oscillation signal. The RF signal is input to Pins 5 and 6. In normal use, the signal is input to one pin while the other pin is connected to GND via decoupling capacitor. In this case, if the capacitor value for grounding is smaller (6 pF for the example of the Electrical Characteristics Measurement Circuit), the conversion gain has the better frequency characteristics.

## 3) IF amplifier circuit

The mixer output signal is amplified by the IF amplifier and output to Pin 1. The IF output is emitter-follower output and output impedance is approximately  $50\Omega$  (400 MHz).

## 4) PLL oscillation signal output circuit

The output circuit is built in to drive the PLL for tuning. This is emitter-follower output and output impedance is approximately  $50\Omega$ .

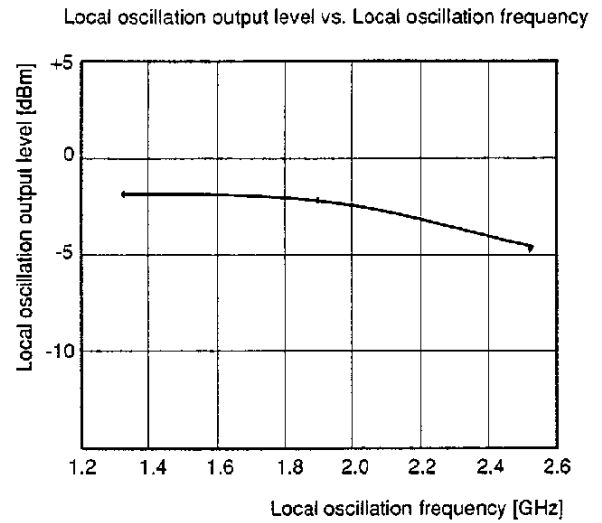
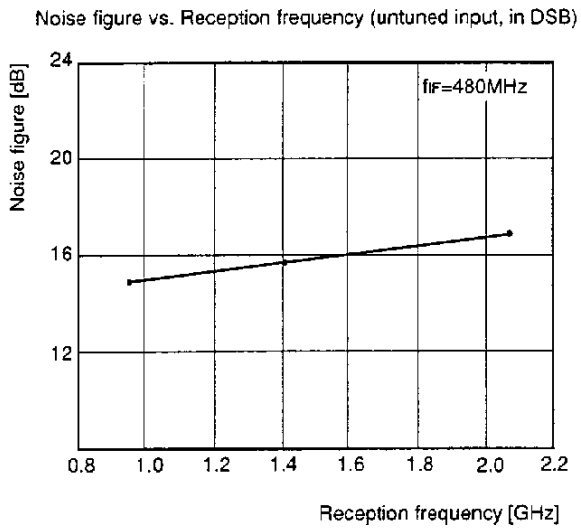
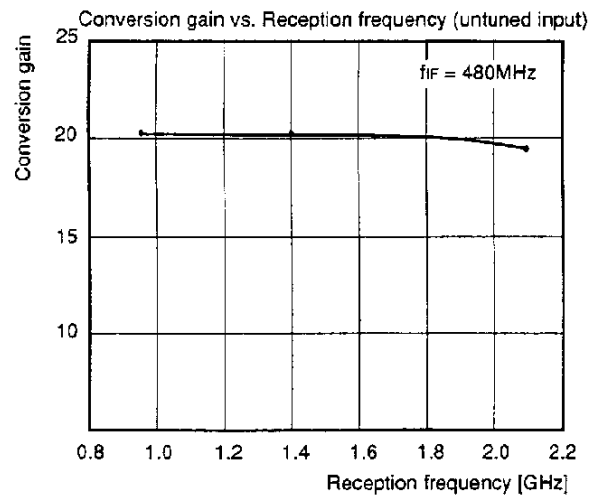
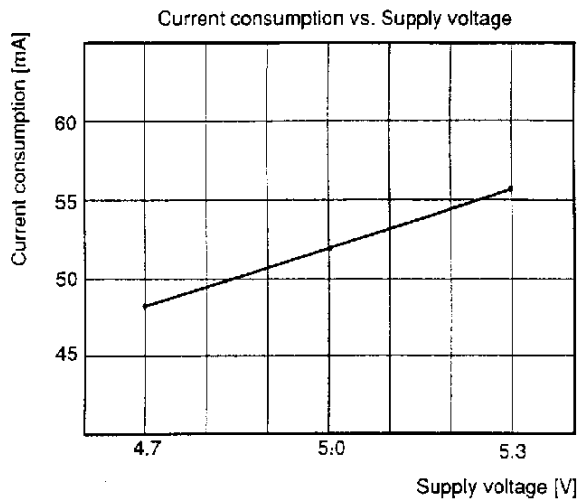



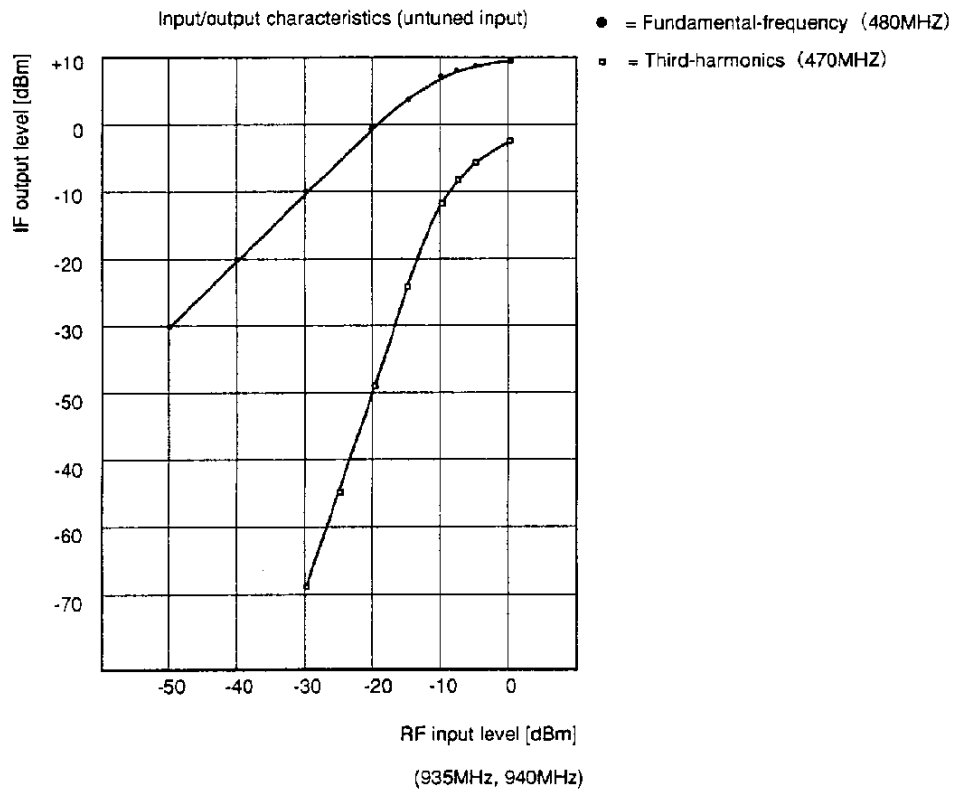
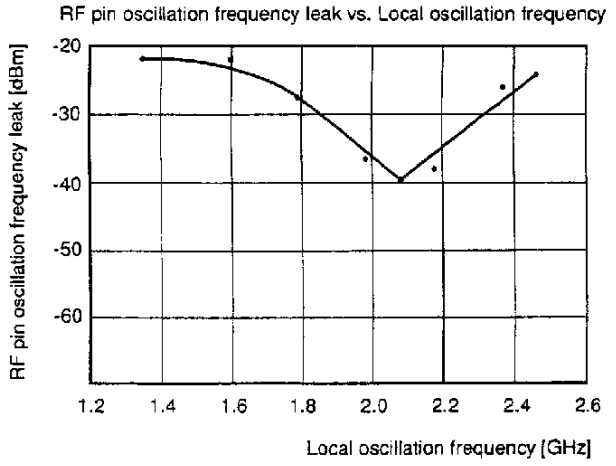
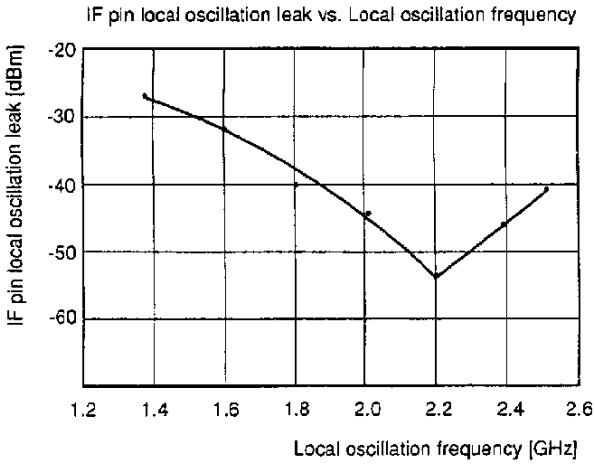

Input Impedance

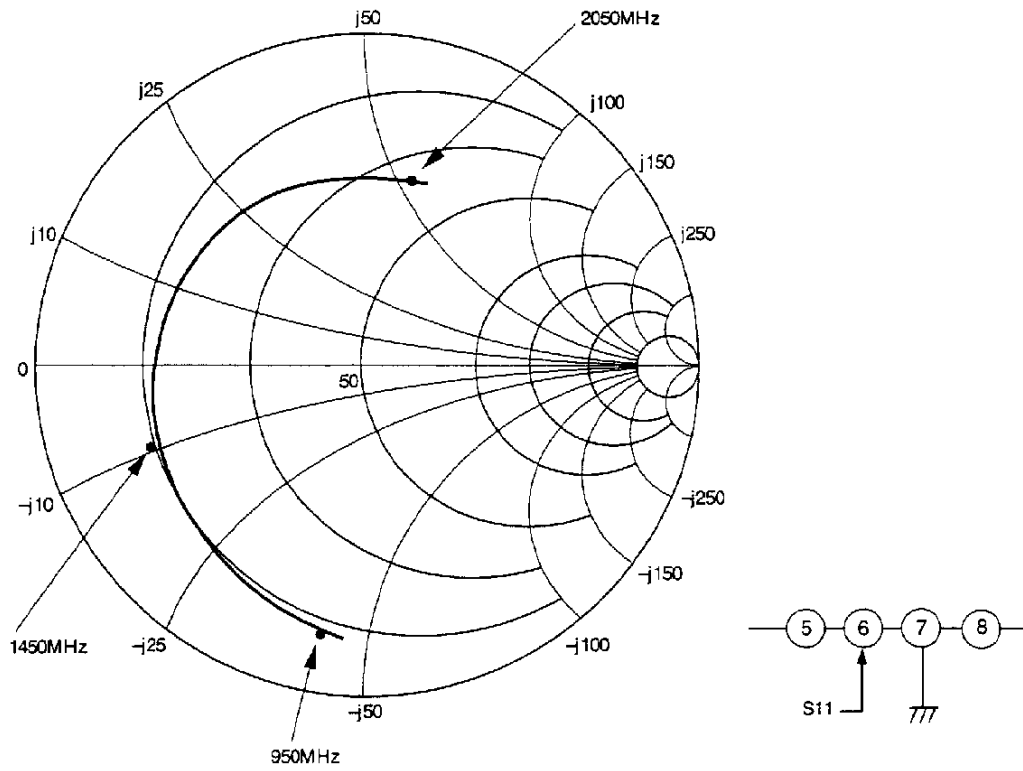

**Output Impedance (IF)**

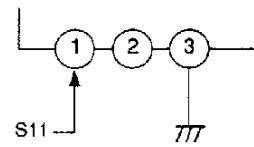
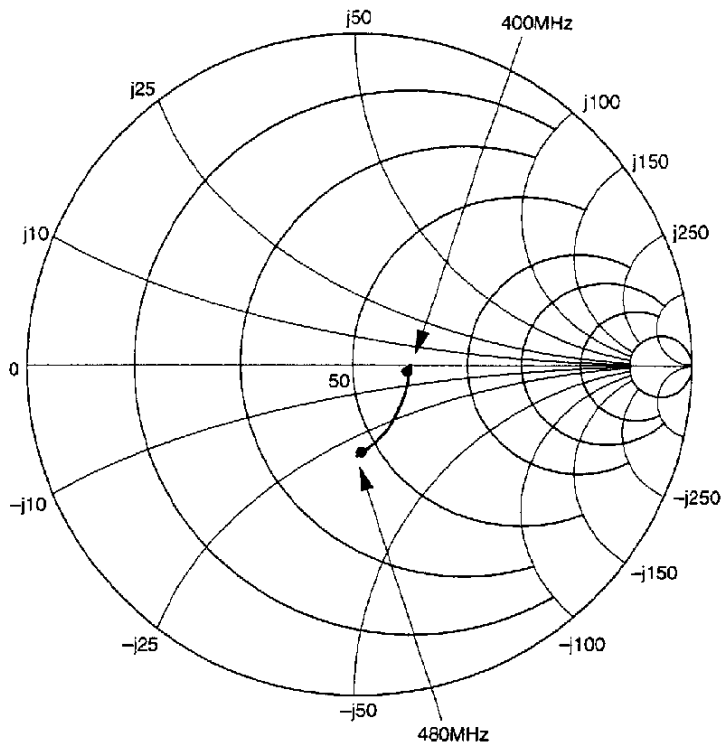

**Output Impedance (local oscillation output)**

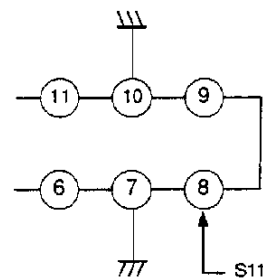
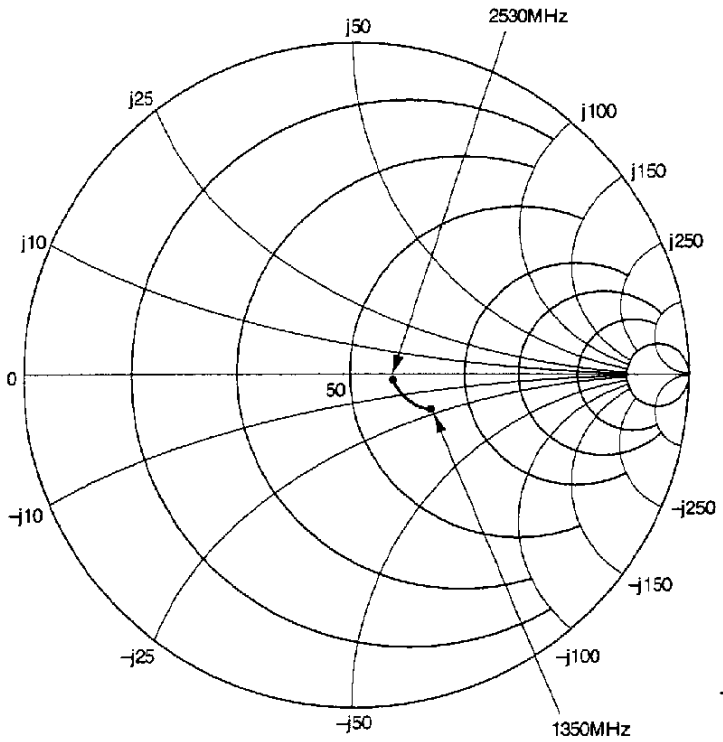

Package Outline Unit : mm

16PIN SSOP (Plastic)

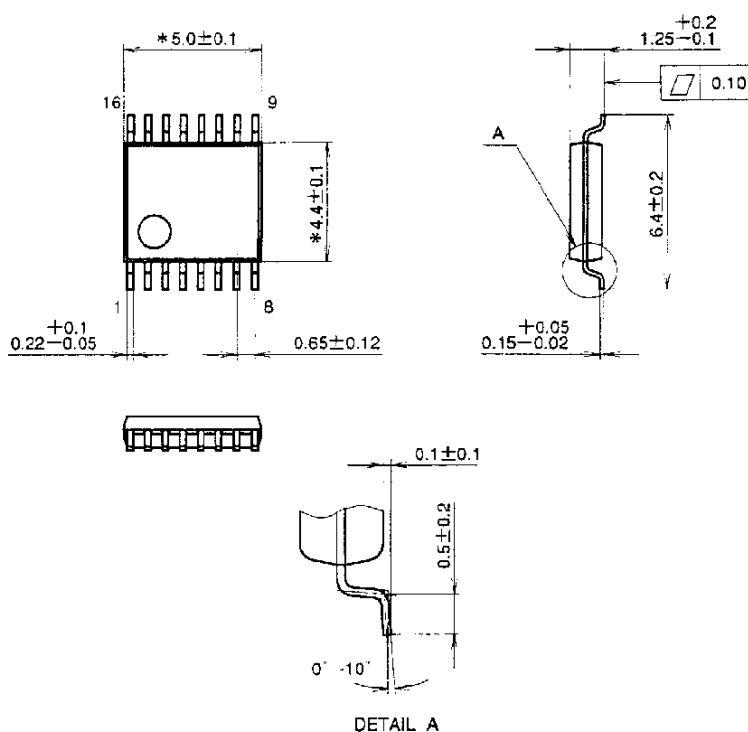

NOTE > Dimension "\*" does not include mold protrusion.

PACKAGE STRUCTURE

SONY CODE	SSOP-16P-L01
EIAJ CODE	SSOP016-P-0044-A
JEDEC CODE	-----

PACKAGE MATERIAL	EPOXY RESIN
LEAD TREATMENT	PALLADIUM PLATING
LEAD MATERIAL	COPPER ALLOY
PACKAGE WEIGHT	0.1g