

M62023L/P/FP

System Reset IC with Switch for 3V Memory Back-up

REJ03D0528-0200
Rev.2.00
Jun 15, 2007

General Description

The M62023L/P/FP is a system reset IC that controls the memory backup function of an SRAM and an embedded RAM of a microcontroller.

The IC outputs reset signals ($\overline{\text{RES}}/\overline{\text{RES}}$) to a microcontroller at power-down and power failure. It also shifts the power supply to RAMs from main to backup, outputs a signal ($\overline{\text{CS}}$) that invokes standby mode, and alters RAMs to backup circuit mode.

Features

- Built-in switch for selection between main power supply and backup power supply to RAMs
- Small difference between input and output voltages ($I_{\text{OUT}} = 80\text{mA}$, $V_{\text{IN}}=3\text{V}$): 0.15V typ.
- Detection voltage (power supply monitor voltage): 2.57V typ.
- Chip select signal output ($\overline{\text{CS}}$)
- Two channels of reset outputs ($\overline{\text{RES}}/\overline{\text{RES}}$)
- Power on reset circuit.

Application

Power supply control systems for memory of microcontroller systems in electronic equipment such as OA equipment, industrial equipment, and home-use electronic appliances and SRAM boards with built-in backup function that require switching between external power supply and battery.

Block Diagram

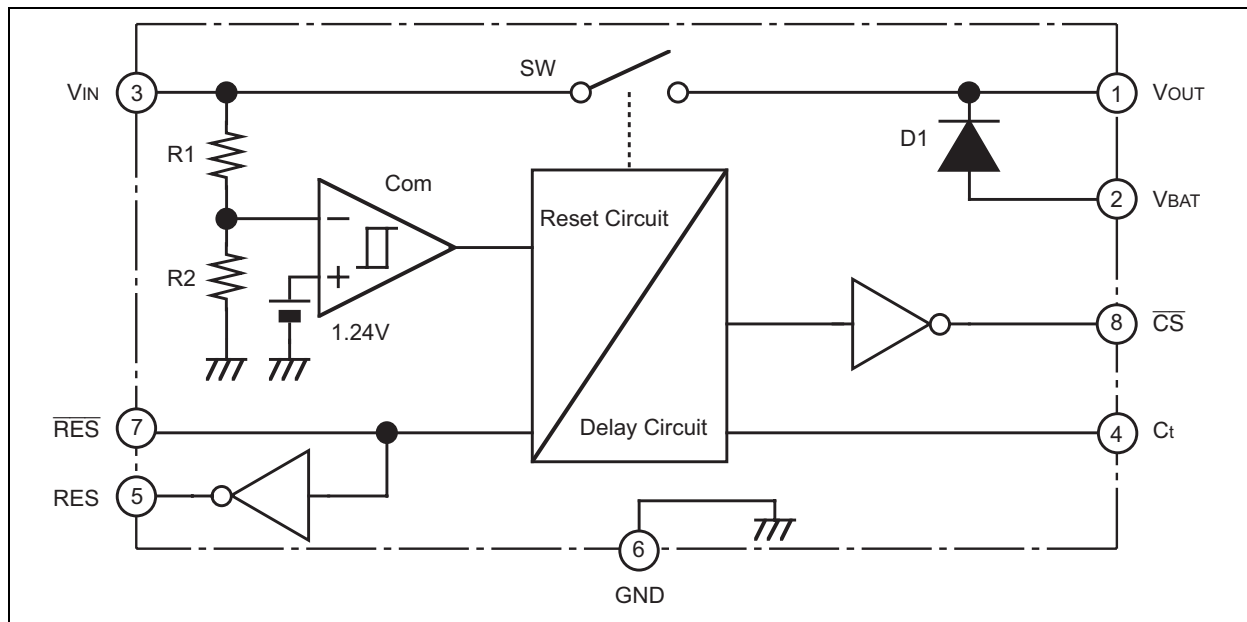

Pin Arrangement

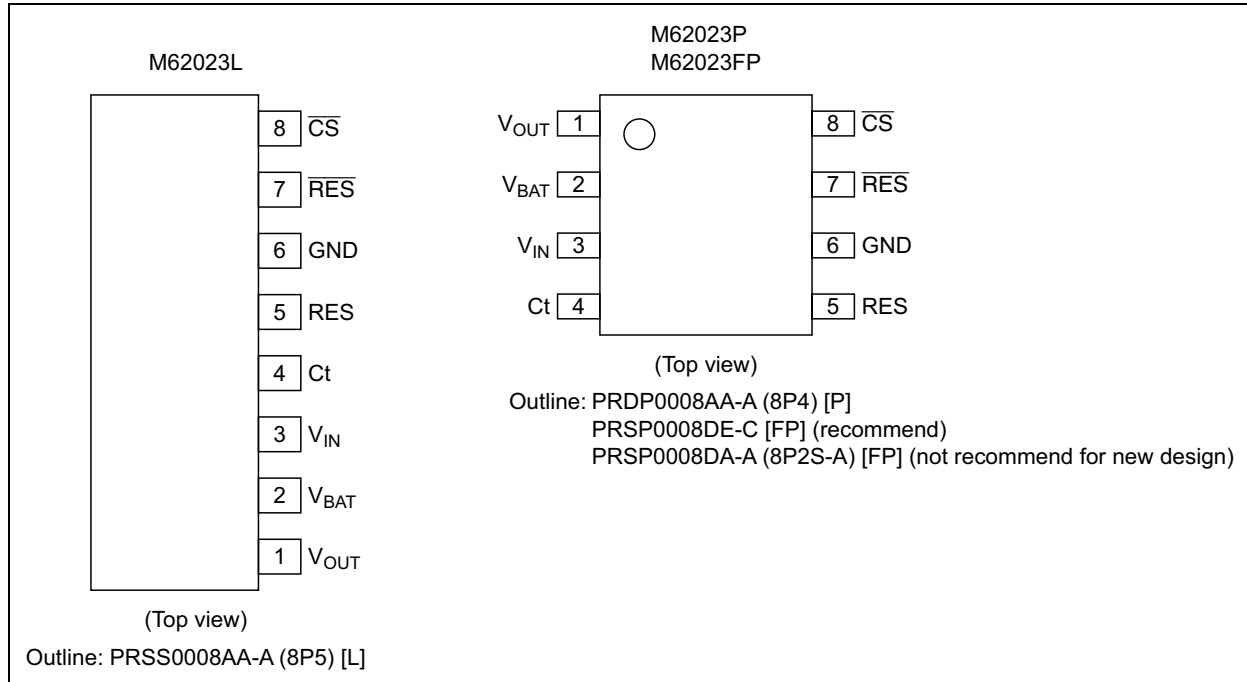

Pin Description

Pin No.	Symbol	Name	Function
1	V_{OUT}	Power supply output	V_{IN} and V_{BAT} are controlled by means of an internal switch and output through V_{OUT} . The pin is capable of outputting up to 100mA. Use it as V_{DD} of CMOS RAM and the like.
2	V_{BAT}	Backup power supply input	Backup power supply is connected to this pin. If a lithium battery is used, insert a resistor in series for safety purposes.
3	V_{IN}	Power supply input	+3V input pin. Connect to a logic power supply.
4	C_t	Delay capacitor connection pin	A delay capacitor is connected to this pin. By connecting a capacitor, it is possible to delay each output.
5	RES	Positive reset output	Connect to the positive reset input of a microcontroller. The pin is capable of flowing 1mA sink current.
6	GND	Ground	Reference for all signals.
7	\overline{RES}	Negative reset output	Connect to the negative reset input of a microcontroller. The pin is capable of flowing 1mA sink current.
8	\overline{CS}	Chip select output	Connect to the $\overline{\text{Chip Select}}$ of RAM. The CS output is at low level in normal state thereby letting RAM be active. Under failure or backup condition, the CS output is set to high level, then RAM enters standby state disabling read/write function. The pin is capable of flowing a 1mA sink current.

Absolute Maximum Ratings

(Ta = 25°C, unless otherwise noted.)

Item	Symbol	Ratings	Unit	Conditions
Input voltage	V _{IN}	7	V	
Output current	I _{OUT}	100	mA	
Power dissipation	P _d	800 (L) / 625 (P) / 440 (FP)	mW	
Thermal derating	K _θ	8 (L) / 6.25 (P) / 4.4 (FP)	mW/°C	Ta ≥ 25°C
Operating temperature	Topr	-20 to +75	°C	
Storage temperature	Tstg	-40 to +125	°C	

Electrical Characteristics

(Ta = 25°C, unless otherwise noted.)

Item	Symbol	Min	Typ	Max	Unit	Test Conditions
Detection voltage	V _S	2.44	2.57	2.70	V	V _{IN} (At change from H→L)
Hysteresis voltage	ΔV _S	50	100	200	mV	ΔV _S = V _{SH} - V _{SL}
Circuit current	I _{CC}	—	1.5	3.0	mA	I _{OUT} = 0mA V _{IN} = 2V
		—	6.5	10		
Difference between input and output voltage	V _{DROP}	—	0.1	0.2	V	V _{IN} = 3V I _{OUT} = 50mA
		—	0.15	0.3		
Ct output voltage (high level)	V _{OH(Ct)}	2.0	2.4	—	V	V _{IN} = 3V *1
Ct output voltage (low level)	V _{OL(Ct)}	—	0.02	0.1	V	V _{IN} = 2V *1
RES output voltage (high level)	V _{OH(RES)}	1.5	2.0	—	V	V _{IN} = 2V *1
RES output voltage (low level)	V _{OL(RES)}	—	0.02	—	V	V _{IN} = 3V *1
		—	0.04	0.2		V _{IN} = 3V, I _{sink} = 1mA
RES output voltage (high level)	V _{OH(RES)}	2.5	3.0	—	V	V _{IN} = 3V *1
RES output voltage (low level)	V _{OL(RES)}	—	0.02	—	V	V _{IN} = 2V *1
		—	0.04	0.2		V _{IN} = 2V, I _{sink} = 1mA
CS output voltage (high level)	V _{OH(CS)}	1.3	1.6	—	V	V _{IN} = 2V *2
		2.40	2.47	—		V _{IN} = 0V, V _{BAT} = 3V *2
CS output voltage (low level)	V _{OL(CS)}	—	0.07	—	V	V _{IN} = 3V *1
		—	0.08	0.3		V _{IN} = 3V, I _{sink} = 1mA
Backup Di leak current	I _R	—	—	±0.5	μA	V _{BAT} = 3V V _{IN} = 3V
		—	—	±0.5		
Backup Di forward direction voltage	V _F	—	0.54	0.6	V	I _F = 10μA
Delay time	tpd	10	27	55	ms	V _{IN} = 0V→3V, Ct = 4.7μF
Response time	td	—	5.0	25.0	μs	V _{IN} = 3V→2V
RES limit voltage of operation	V _{OPL(RES)}	—	0.65	—	V	*3

Notes: 1. Regarding conditions to measure V_{OH} and V_{OL}, voltage values are generated by internal resistance only and no external resistor is used.

2. These values are produced inserting an external resistor, R_{CS} = 1MΩ, between the CS pin and GND.

3. With no external resistor (10kΩ internal resistance only).

Application Example

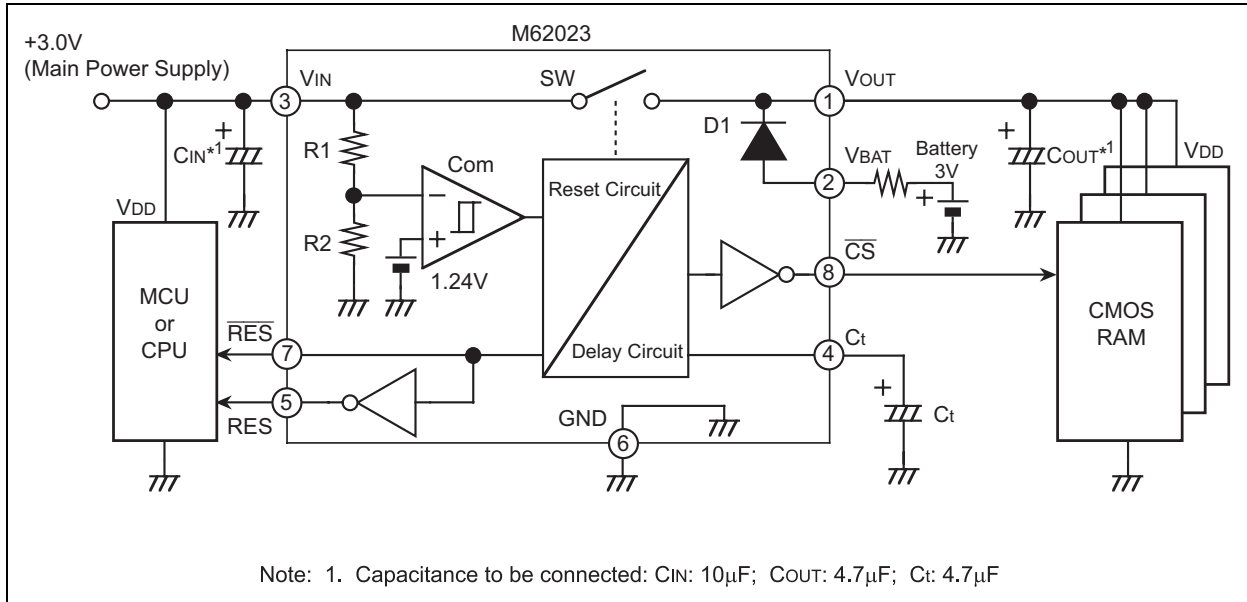

Configuration

<Power supply detector>

The internal reference voltage V_{ref} is compared by means of a comparator with resistor divided voltage V_R (resistor-divided voltage produced by R_1 and R_2 from V_{IN}).

If the input voltage is 3V, V_R is set to 1.24V or higher, so the comparator output is at low level and the Ct output (Q1 collector output) is set to high level. If the input voltage drops to below 2.57V in an abnormal condition, V_R becomes below 1.24V, so the comparator output goes from low to high level and the Ct output, from high to low. The input voltage at this point is called V_{SL} . Next, when the input voltage, restored from abnormal state, has a rise, the comparator output goes from high to low level and the Ct output, from low to high.

The comparator used for detection has 100mV hysteresis (ΔV_s), so that malfunctioning is prevented in case that the input voltage slowly drops or V_R nearly equals V_{ref} .

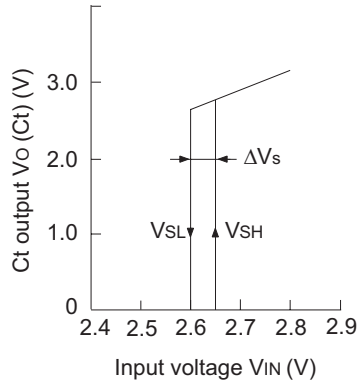

<Delay Circuit>

Connecting an external capacitor to the Ct pin lets \overline{RES} , \overline{RES} , \overline{CS} , and V_{OUT} be delayed due to RC transient phenomenon (electric charge).

Delay time is determined as follows.

$$\begin{aligned} \text{Delay time (tpd)} &= C_t \times R_3 \times \ln \frac{[V_{OH}(Ct) - V_{OL}(Ct)]}{[V_{OH}(Ct) - INV1(V_{TH})]} \\ &= C_t \times 22k\Omega \times 0.2389 \\ &\cong 5.26 \times 10^3 \times C_t \end{aligned}$$

Note: C_t is an external capacitance.

Taking into consideration the time taken by the oscillator of microcomputer to be stable, connect a 4.7 μ F capacitor to the Ct pin.

(As the response time of detection can be slowed due to internal structure depending on the rising rate of power supply, avoid connecting a too large capacitance.)

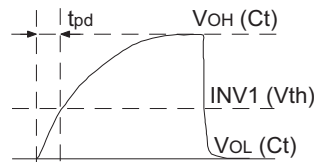

Delayed output waveforms of Ct

<Schmitt trigger circuit>

Since waveforms show a gentle rise due to the RC delay circuit, INV1, INV2, and R6 constitute a Schmitt trigger circuit to produce hysteresis so as to prevent each output from chattering.

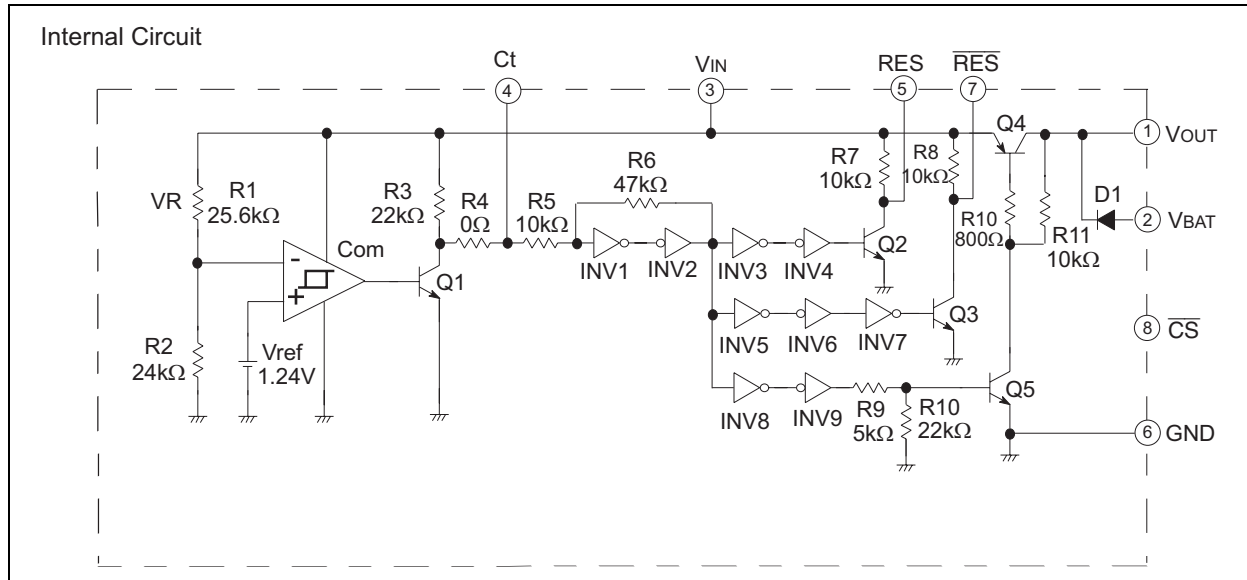

Timing Chart

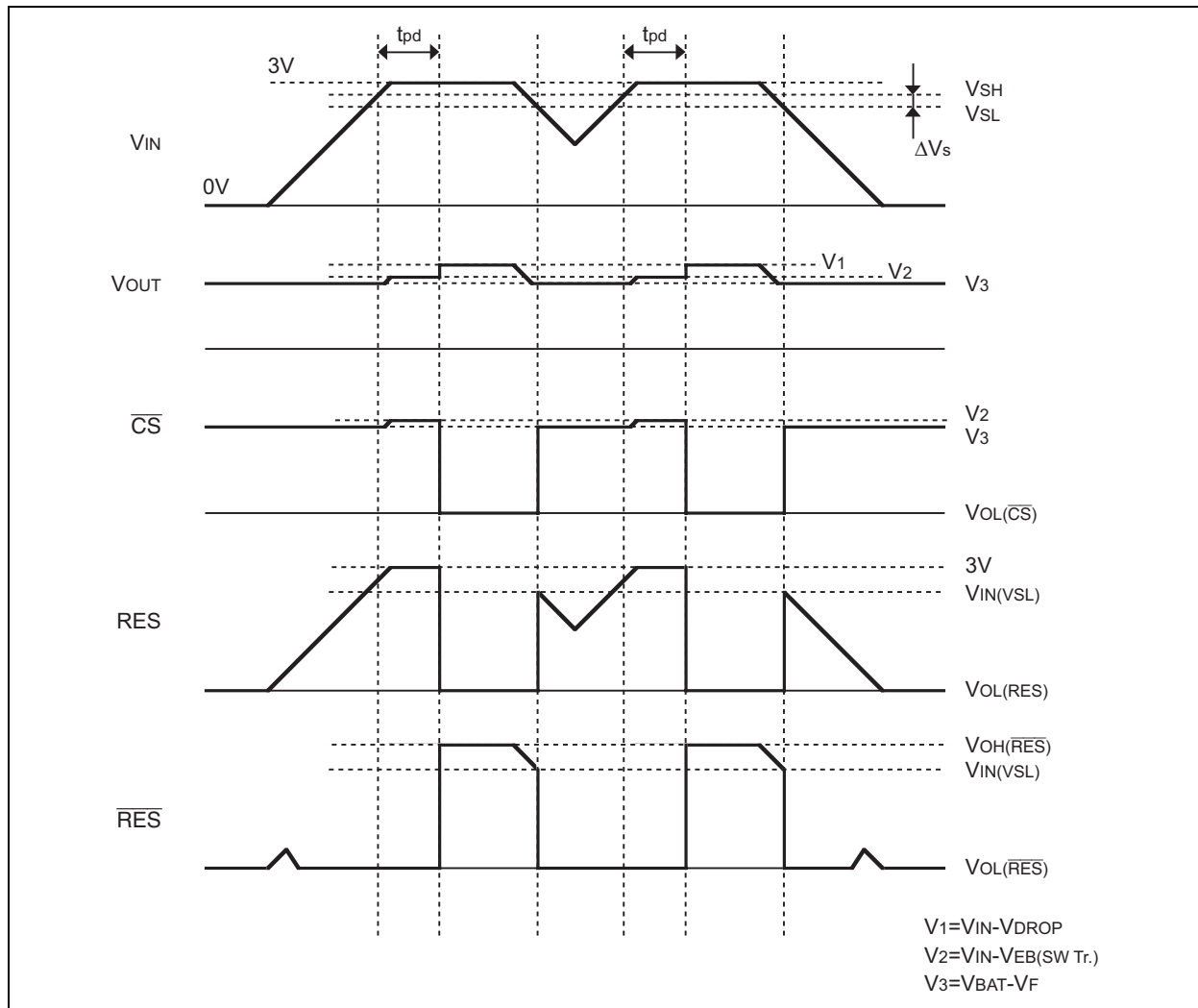

Output pin	Input voltage			
	In normal operation	In failure (instantaneous drop)	Restoration from failure (instantaneous drop)	In backup state
	Input voltage: 3V	Input voltage: 3V→2V Each output varies if the input voltage drops to V_{SL} or under	Input voltage: 2V→3V If the input voltage goes higher than V_{SL} by 100mV, each output varies after delay produced by the delay circuit.	Input voltage: 0V Backup voltage: 3V
V _{OUT}	With SW Tr. set to ON, a voltage ($V_{IN} - V_{DROP}$) is output.	SW Tr. is turned OFF. A voltage ($V_{IN} - V_{EB}$) is output by the diode between E and B of SW Tr.	SW Tr. is turned ON after delay and a voltage ($V_{IN} - V_{DROP}$) is output.	$V_{BAT} - V_F$
RES	The output level is $V_{OL(RES)}$ with a logic low.	As the state shifts from a logic low to logic high, the output level becomes approximately equal to the input voltage.	A logic high is maintained, and then shifts to a logic low.	—————
\overline{RES}	The output level is $V_{OH(RES)}$ with a logic high.	As the state shifts from a logic high to logic low, the output level becomes $V_{OL(RES)}$	A logic low is maintained, and then shifts to a logic high.	—————
\overline{CS}	The output level is $V_{OL(CS)}$ with a logic low.	As the state shifts from a logic low to logic high, the output level becomes the voltage $V_{IN} - V_{EB}$.	A logic high is maintained, and then shifts to a logic low.	The output is a logic high and the output level is $V_{BAT} - V_F$

Typical Characteristics

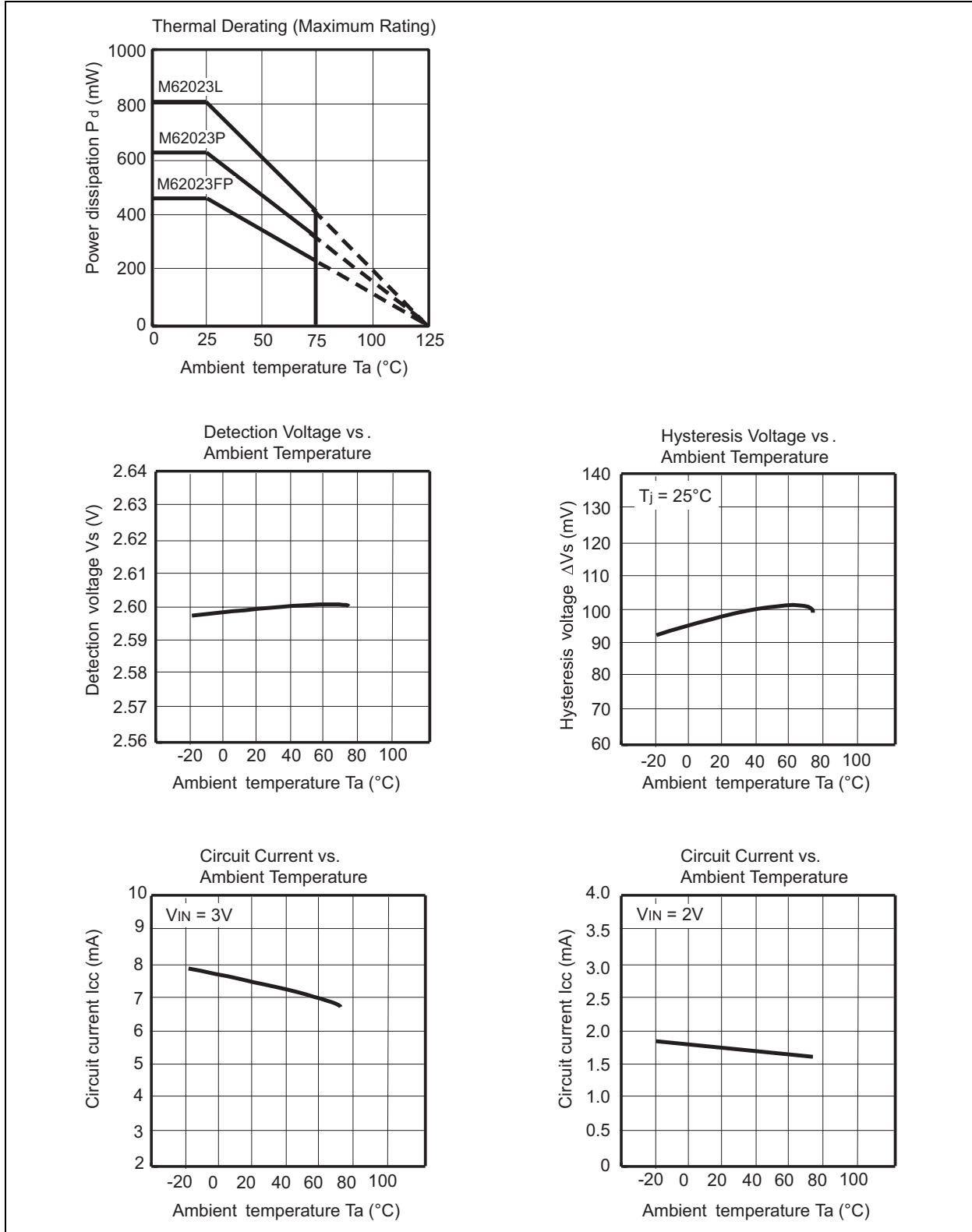

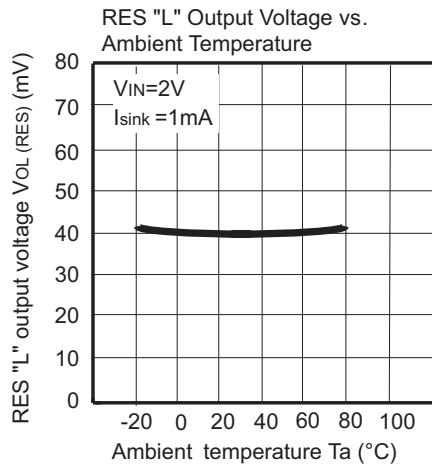
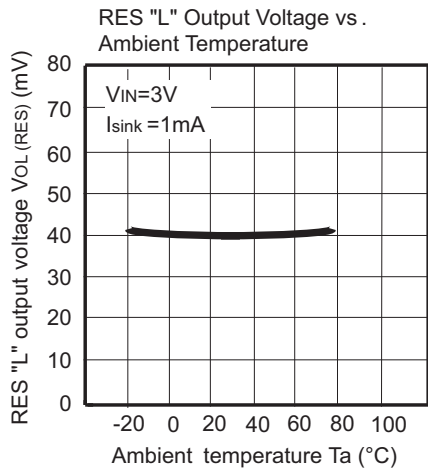
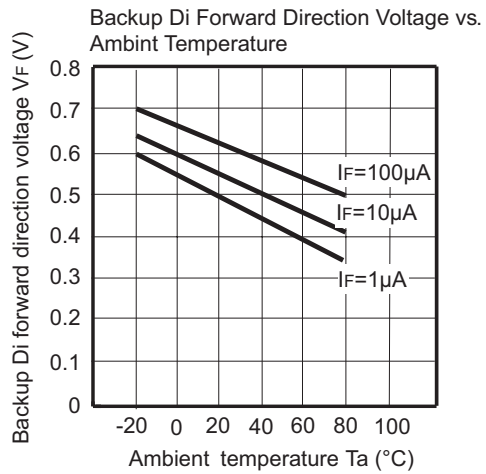
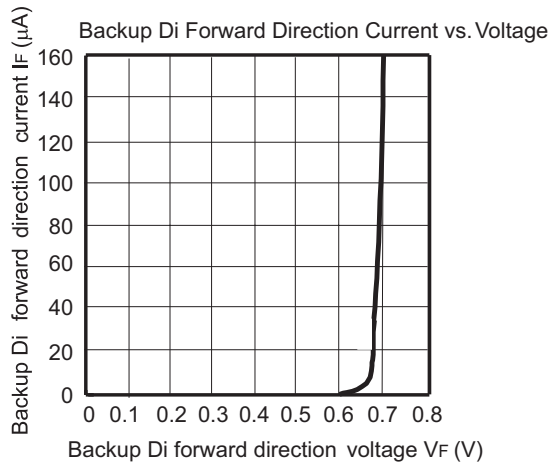
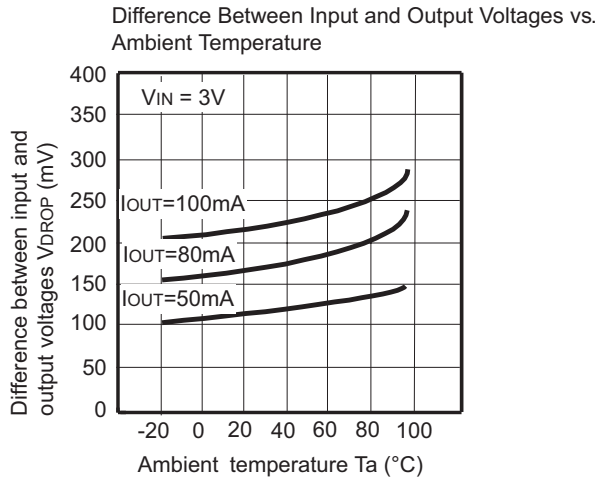
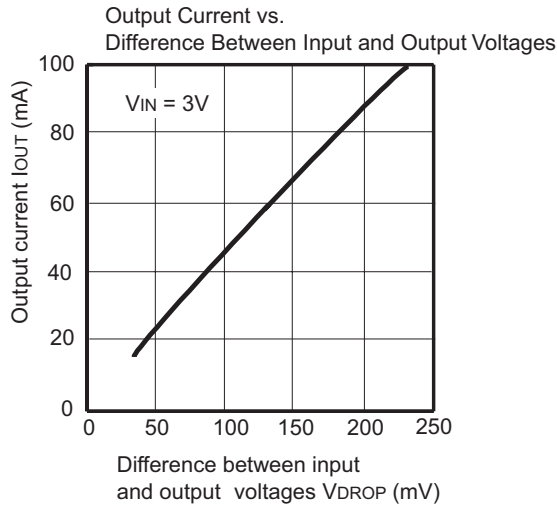

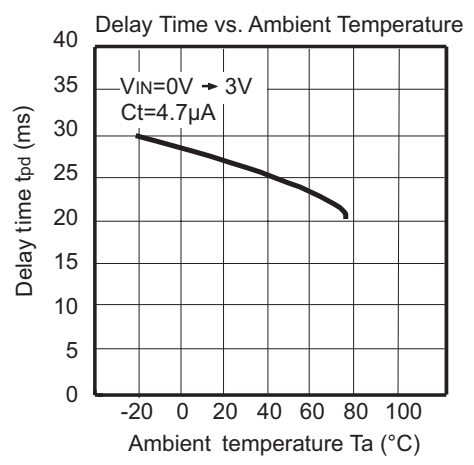
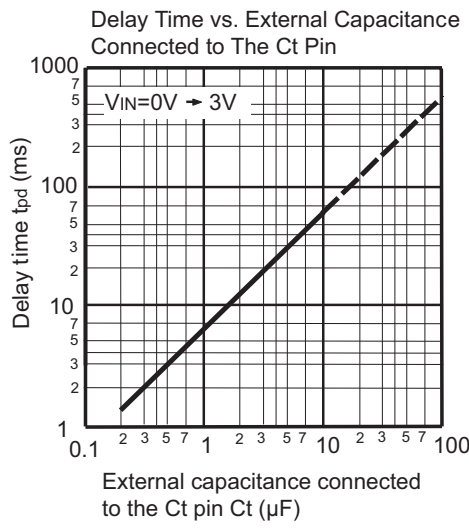
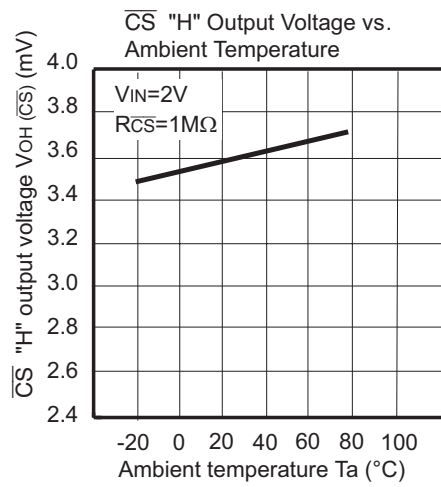
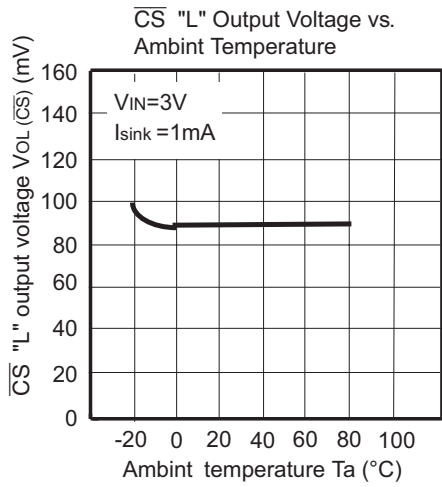

Package Dimensions

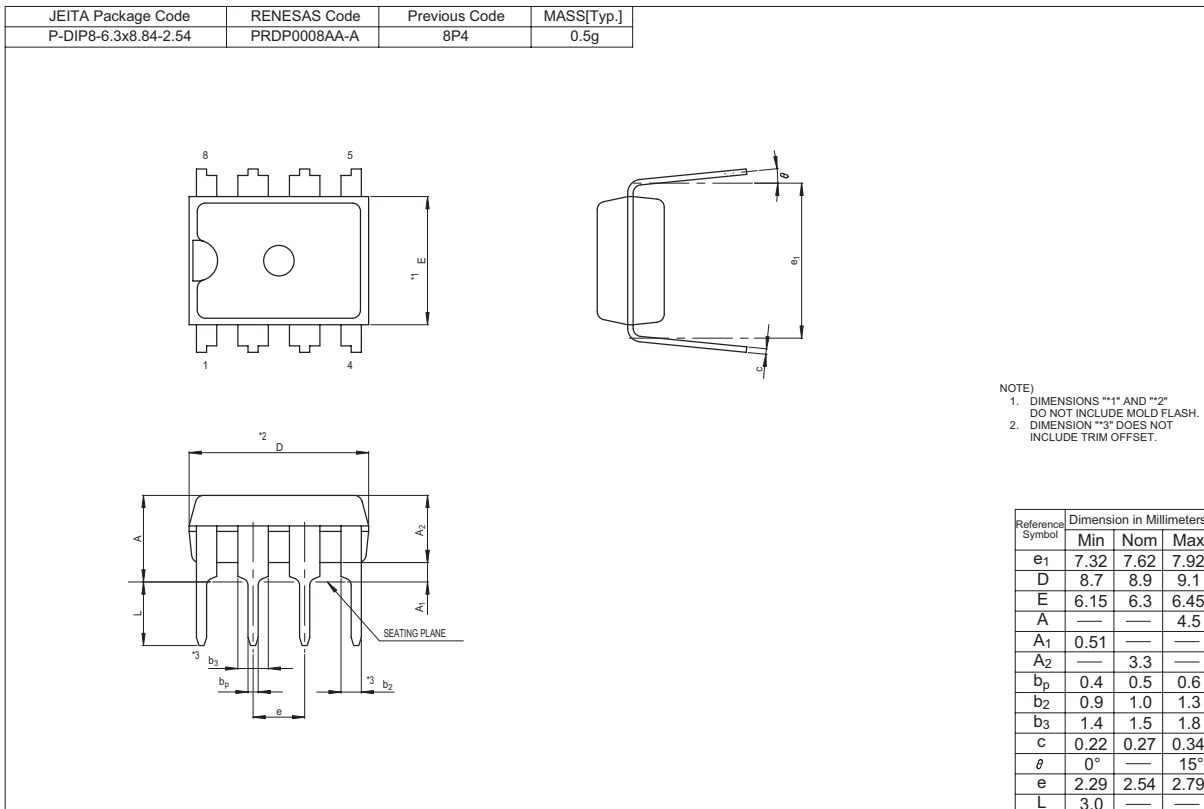
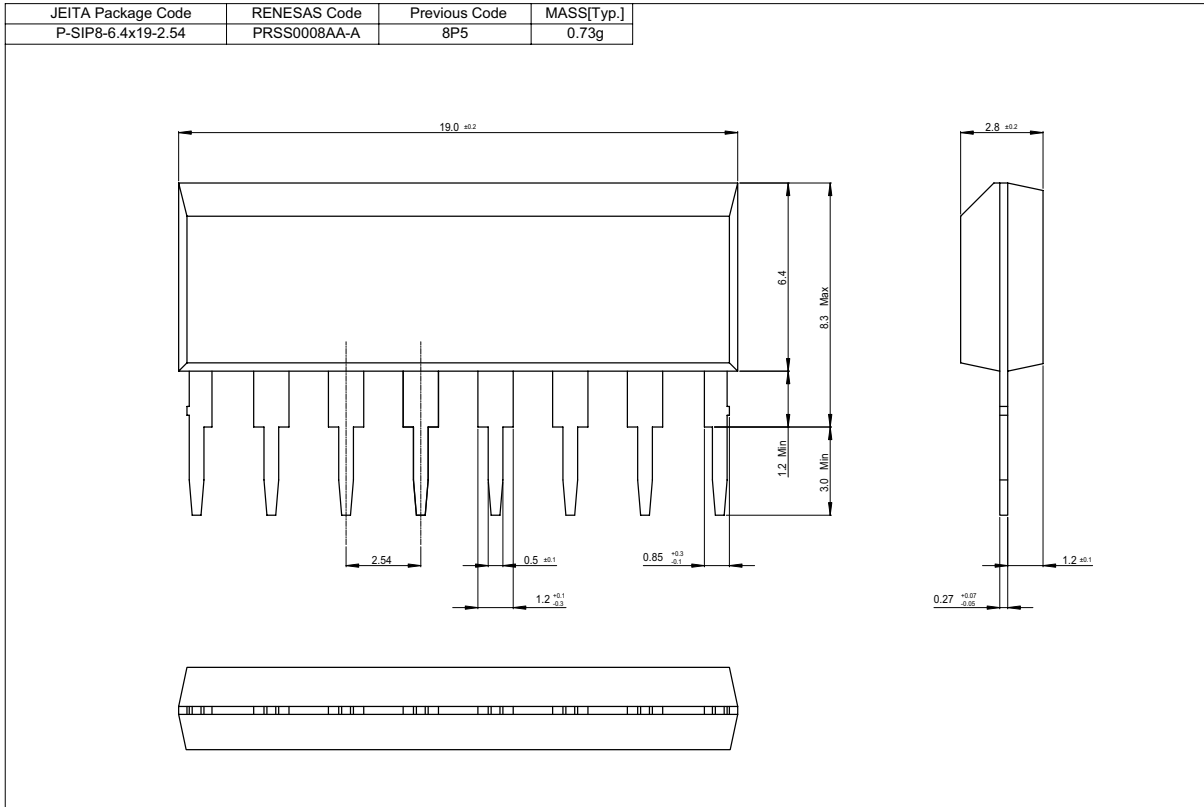

JEITA Package Code	RENESAS Code	Previous Code	MASS[Typ.]
P-SOP8-4.4x4.85-1.27	PRSP0008DE-C	—	0.1g

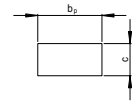
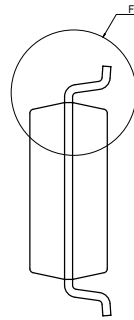
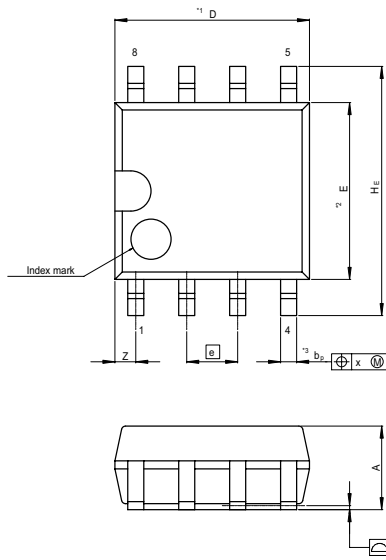

Terminal cross section
(Ni/Pd/Au plating)

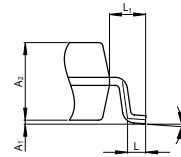

Detail F

NOTE)
1. DIMENSIONS **1 (Nom) AND **2"
DO NOT INCLUDE MOLD FLASH.
2. DIMENSION **3 DOES NOT
INCLUDE TRIM OFFSET.

Reference Symbol	Dimension in Millimeters		
	Min	Nom	Max
D	4.65	4.85	5.05
E	4.2	4.4	4.6
A ₂	—	1.85	—
A ₁	0.00	0.1	0.20
A	—	—	2.03
b _p	0.34	0.4	0.46
b ₁	—	—	—
c	0.15	0.20	0.25
c ₁	—	—	—
θ	0°	—	8°
H _E	5.7	6.2	6.5
⌀	1.12	1.27	1.42
x	—	—	0.12
y	—	—	0.10
z	—	—	0.75
L	0.25	0.45	0.65
L ₁	—	0.90	—

JEITA Package Code	RENESAS Code	Previous Code	MASS[Typ.]
P-SOP8-4.4x5-1.27	PRSP0008DA-A	8P2S-A	0.07g

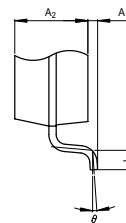
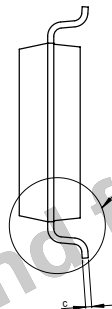
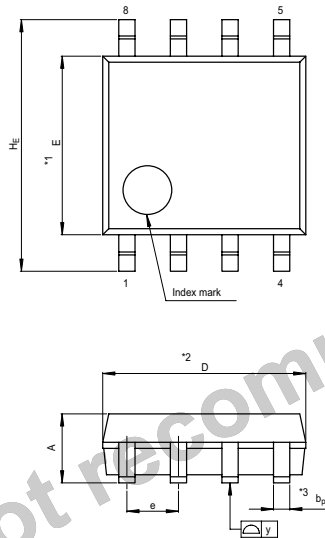

Detail F

NOTE)
1. DIMENSIONS **1* AND **2"
DO NOT INCLUDE MOLD FLASH.
2. DIMENSION **3 DOES NOT
INCLUDE TRIM OFFSET.

Reference Symbol	Dimension in Millimeters		
	Min	Nom	Max
D	4.8	5.0	5.2
E	4.2	4.4	4.6
A ₂	—	1.5	—
A ₁	0.05	—	—
A	—	—	1.9
b _p	0.35	0.4	0.5
c	0.13	0.15	0.2
θ	0°	—	10°
H _E	5.9	6.2	6.5
e	1.12	1.27	1.42
y	—	—	0.1
L	0.2	0.4	0.6

Notes:

1. This document is provided for reference purposes only so that Renesas customers may select the appropriate Renesas products for their use. Renesas neither makes warranties or representations with respect to the accuracy or completeness of the information contained in this document nor grants any license to any intellectual property rights or any other rights of Renesas or any third party with respect to the information in this document.
2. Renesas shall have no liability for damages or infringement of any intellectual property or other rights arising out of the use of any information in this document, including, but not limited to, product data, diagrams, charts, programs, algorithms, and application circuit examples.
3. You should not use the products or the technology described in this document for the purpose of military applications such as the development of weapons of mass destruction or for the purpose of any other military use. When exporting the products or technology described herein, you should follow the applicable export control laws and regulations, and procedures required by such laws and regulations.
4. All information included in this document such as product data, diagrams, charts, programs, algorithms, and application circuit examples, is current as of the date this document is issued. Such information, however, is subject to change without any prior notice. Before purchasing or using any Renesas products listed in this document, please confirm the latest product information with a Renesas sales office. Also, please pay regular and careful attention to additional and different information to be disclosed by Renesas such as that disclosed through our website. (<http://www.renesas.com>)
5. Renesas has used reasonable care in compiling the information included in this document, but Renesas assumes no liability whatsoever for any damages incurred as a result of errors or omissions in the information included in this document.
6. When using or otherwise relying on the information in this document, you should evaluate the information in light of the total system before deciding about the applicability of such information to the intended application. Renesas makes no representations, warranties or guarantees regarding the suitability of its products for any particular application and specifically disclaims any liability arising out of the application and use of the information in this document or Renesas products.
7. With the exception of products specified by Renesas as suitable for automobile applications, Renesas products are not designed, manufactured or tested for applications or otherwise in systems the failure or malfunction of which may cause a direct threat to human life or create a risk of human injury or which require especially high quality and reliability such as safety systems, or equipment or systems for transportation and traffic, healthcare, combustion control, aerospace and aeronautics, nuclear power, or undersea communication transmission. If you are considering the use of our products for such purposes, please contact a Renesas sales office beforehand. Renesas shall have no liability for damages arising out of the uses set forth above.
8. Notwithstanding the preceding paragraph, you should not use Renesas products for the purposes listed below:
 - (1) artificial life support devices or systems
 - (2) surgical implantations
 - (3) healthcare intervention (e.g., excision, administration of medication, etc.)
 - (4) any other purposes that pose a direct threat to human lifeRenesas shall have no liability for damages arising out of the uses set forth in the above and purchasers who elect to use Renesas products in any of the foregoing applications shall indemnify and hold harmless Renesas Technology Corp., its affiliated companies and their officers, directors, and employees against any and all damages arising out of such applications.
9. You should use the products described herein within the range specified by Renesas, especially with respect to the maximum rating, operating supply voltage range, movement power voltage range, heat radiation characteristics, installation and other product characteristics. Renesas shall have no liability for malfunctions or damages arising out of the use of Renesas products beyond such specified ranges.
10. Although Renesas endeavors to improve the quality and reliability of its products, IC products have specific characteristics such as the occurrence of failure at a certain rate and malfunctions under certain use conditions. Please be sure to implement safety measures to guard against the possibility of physical injury, and injury or damage caused by fire in the event of the failure of a Renesas product, such as safety design for hardware and software including but not limited to redundancy, fire control and malfunction prevention, appropriate treatment for aging degradation or any other applicable measures. Among others, since the evaluation of microcomputer software alone is very difficult, please evaluate the safety of the final products or system manufactured by you.
11. In case Renesas products listed in this document are detached from the products to which the Renesas products are attached or affixed, the risk of accident such as swallowing by infants and small children is very high. You should implement safety measures so that Renesas products may not be easily detached from your products. Renesas shall have no liability for damages arising out of such detachment.
12. This document may not be reproduced or duplicated, in any form, in whole or in part, without prior written approval from Renesas.
13. Please contact a Renesas sales office if you have any questions regarding the information contained in this document, Renesas semiconductor products, or if you have any other inquiries.



RENESAS SALES OFFICES

<http://www.renesas.com>

Refer to "<http://www.renesas.com/en/network>" for the latest and detailed information.

Renesas Technology America, Inc.
450 Holger Way, San Jose, CA 95134-1368, U.S.A
Tel: <1> (408) 382-7500, Fax: <1> (408) 382-7501

Renesas Technology Europe Limited
Dukes Meadow, Millboard Road, Bourne End, Buckinghamshire, SL8 5FH, U.K.
Tel: <44> (1628) 585-100, Fax: <44> (1628) 585-900

Renesas Technology (Shanghai) Co., Ltd.
Unit 204, 205, AZIA Center, No.1233 Lujiazui Ring Rd, Pudong District, Shanghai, China 200120
Tel: <86> (21) 5877-1818, Fax: <86> (21) 6887-7898

Renesas Technology Hong Kong Ltd.
7th Floor, North Tower, World Finance Centre, Harbour City, 1 Canton Road, Tsimshatsui, Kowloon, Hong Kong
Tel: <852> 2265-6688, Fax: <852> 2730-6071

Renesas Technology Taiwan Co., Ltd.
10th Floor, No.99, Fushing North Road, Taipei, Taiwan
Tel: <886> (2) 2715-2888, Fax: <886> (2) 2713-2999

Renesas Technology Singapore Pte. Ltd.
1 Harbour Front Avenue, #06-10, Keppel Bay Tower, Singapore 098632
Tel: <65> 6213-0200, Fax: <65> 6278-8001

Renesas Technology Korea Co., Ltd.
Kukje Center Bldg. 18th Fl., 191, 2-ka, Hangang-ro, Yongsan-ku, Seoul 140-702, Korea
Tel: <82> (2) 796-3115, Fax: <82> (2) 796-2145

Renesas Technology Malaysia Sdn. Bhd
Unit 906, Block B, Menara Amcorp, Amcorp Trade Centre, No.18, Jalan Persiaran Barat, 46050 Petaling Jaya, Selangor Darul Ehsan, Malaysia
Tel: <603> 7955-9390, Fax: <603> 7955-9510