

I²C Bus Controlled 4-Input 1-Output AV Switch Monolithic IC MM1311

June 17, 1999

Outline

This IC is an I²C bus controlled AV switch IC with 4-input 1-output developed for TVs.

Features

1. Serial control by I²C bus
2. 4 inputs and 1 output
3. Video and audio switches can be controlled independently.
4. Includes a 6dB amp in the video channel
5. Incorporates a Y/C mix circuit
6. Slave address can be changed to 90H or 92H.
7. Enables audio mute with an external pin
8. I²C bus lines (SDA, SCL) maintain high impedance during power-off.
9. Includes a tri-stated detection function
10. Includes a power-on reset function
11. Two types of audio input impedance are available ; 60k Ω and 30k Ω
 MM1311AD : 60k Ω MM1311BD : 30k Ω

Package

SDIP-32A (MM1311AD, MM1311BD)

Applications

1. Televisions
2. Other video equipment

Equivalent Block Diagram

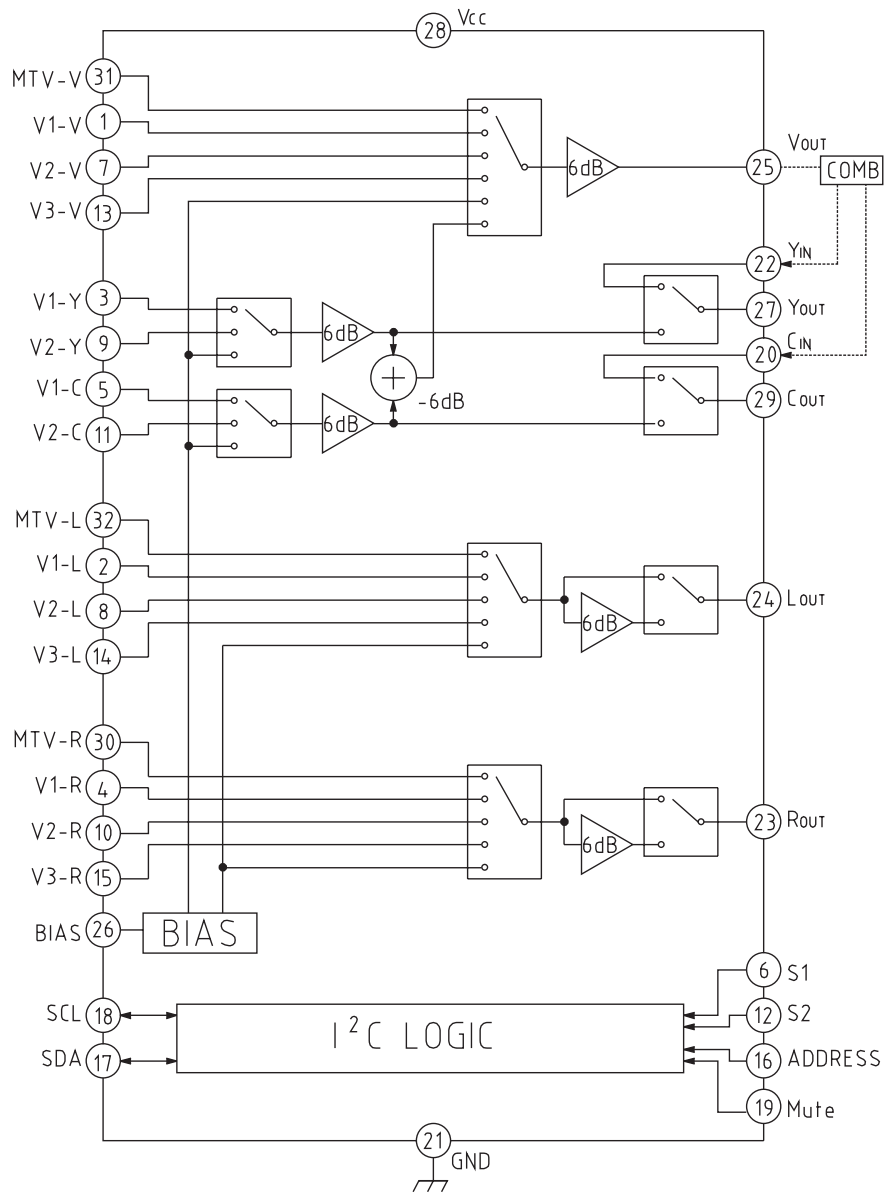

Pin Description

Pin No.	Name	Internal equivalent circuit diagram	Pin No.	Name	Internal equivalent circuit diagram
31 1 7 13 3 9 22	MTV-V V1-V V2-V V3-V V1-Y V2-Y Y _{IN}		27 29	Y _{OUT} C _{OUT}	
5 11 20	V1-C V2-C C _{IN}		24 23	L _{OUT} R _{OUT}	
32 2 8 14 30 4 10 15	MTV-L V1-L V2-L V3-L MTV-R V1-R V2-R V3-R		26	BIAS	
25	V _{OUT}		18	SCL	
			17	SDA	
			6 12 16 19	S1 S2 ADR Mute	

Absolute Maximum Ratings (Ta=25°C)

Item	Symbol	Ratings	Units
Storage temperature	T _{STG}	-40~+125	°C
Operating temperature	T _{OPR}	-20~+75	°C
Power supply voltage	V _{CC}	12	V
Allowable power dissipation	P _d	1500	mW

Electrical Characteristics (Ta=25°C, Vcc=9V)

Item	Symbol	Measurement pin	Conditions (unless otherwise indicated, Measurement Circuit Figure 1)	Min.	Typ.	Max.	Units
Operating power supply voltage	V _{CC}			8	9	10	V
Current consumption	I _{CC}	28	V _{CC} =9V, no signal, no load		27	35	mA
V_{OUT} output							
Voltage gain	G _V	TP1	Sine wave, 1.0V _{P-P} , 100kHz	5.5	6.0	6.5	dB
Frequency characteristics	F _V	TP1	Sine wave, 1.0V _{P-P} , 10MHz/100kHz	-1.0	0	1.0	dB
Differential gain	DG _V	TP1	V _n -V : Staircase, 1V _{P-P} APL=10~90% V _n -Y : Staircase (luminance signal) 1V _{P-P} V _n -C : Chroma signal 0.3V _{P-P} APL=10~90%	-3	0	3	%
Differential phase	DP _V	TP1	V _n -V : Staircase, 1V _{P-P} APL=10~90% V _n -Y : Staircase (luminance signal) 1V _{P-P} V _n -C : Chroma signal 0.3V _{P-P} APL=10~90%	-3	0	3	deg
Input dynamic range	D _{v1}	SG 1-3	Sine wave, 100kHz Maximum input for total higher harmonic distortion factor < 1.0%	1.6	1.9		V _{P-P}
Y_{OUT} output							
Voltage gain	G _{Y1}	TP2	V _n -Y : Sine wave, 1.0V _{P-P} , 100kHz	5.5	6.0	6.5	dB
	G _{Y2}	TP2	Y _{IN} : Sine wave, 2.0V _{P-P} , 100kHz	-0.5	0	0.5	
Frequency characteristics	F _{Y1}	TP2	V _n -Y : Sine wave, 1.0V _{P-P} 10MHz/100kHz	-1.0	0	1.0	dB
	F _{Y2}	TP2	Y _{IN} : Sine wave, 2.0V _{P-P} , 10MHz/100kHz	-1.0	0	1.0	
Differential gain	DG _Y	TP2	V _n -Y : Staircase, 1V _{P-P} APL=10~90% Y _{IN} : Staircase, 2V _{P-P} , APL=10~90%	-3	0	3	%
Differential phase	DP _Y	TP2	V _n -Y : Staircase, 1V _{P-P} APL=10~90% Y _{IN} : Staircase, 2V _{P-P} , APL=10~90%	-3	0	3	deg
Input dynamic range	D _{Y1}	SG2	V _n -Y : Sine wave 100kHz Maximum input for total higher harmonic distortion factor < 1.0%	1.6	1.9		V _{P-P}
	D _{Y2}	SG4	Y _{IN} : Sine wave, 100kHz Maximum input for total higher harmonic distortion factor < 1.0%	3.2	3.8		
Output impedance	Z _{OY}				50		Ω
C_{OUT} output							
Voltage gain	G _{C1}	TP3	V _n -C : Sine wave, 1.0V _{P-P} , 100kHz	5.5	6.0	6.5	dB
	G _{C2}	TP3	C _{IN} : Sine wave, 2.0V _{P-P} , 100kHz	-0.5	0	0.5	
Frequency characteristics	F _{C1}	TP3	V _n -C : Sine wave, 1.0V _{P-P} 10MHz/100kHz	-1.0	0	1.0	dB
	F _{C2}	TP3	C _{IN} : Sine wave, 2.0V _{P-P} , 10MHz/100kHz	-1.0	0	1.0	
Differential gain	DG _C	TP3	C _{IN} : Staircase, 2V _{P-P} , APL=10~90%	-3	0	3	%
Differential phase	DP _C	TP3	C _{IN} : Staircase, 2V _{P-P} , APL=10~90%	-3	0	3	deg
Input dynamic range	D _{C1}	SG3	V _n -C : Sine wave, 100kHz Maximum input for total higher harmonic distortion factor < 1.0%	2.75	3.25		V _{P-P}
	D _{C2}	SG5	C _{IN} : Sine wave, 100kHz Maximum input for total higher harmonic distortion factor < 1.0%	5.5	6.5		
Input impedance	Z _{IC}		V _n -C, C _{IN}	10	15	20	kΩ
Output impedance	Z _{OC}				50		Ω
L_{OUT} output							
Voltage gain	G _{L1}	TP4	b7=0, Sine wave, 2.5V _{P-P} , 1kHz	-6.5	-6.0	-5.5	dB
	G _{L2}	TP4	b7=1, Sine wave, 2.5V _{P-P} , 1kHz	-0.5	0	0.5	
Frequency characteristics	F _L	TP4	Sine wave, 2.5V _{P-P} , 1MHz/1kHz	-3.0	0	1.0	dB

Item	Symbol	Measurement pin	Conditions (unless otherwise indicated, Measurement Circuit Figure 1)	Min.	Typ.	Max.	Units
Total higher harmonic distortion	THDL	TP4	Sine wave, 2.5V _{P-P} , 1kHz		0.03	0.1	%
Input dynamic range	DL	SG6	Sine wave, 1kHz Maximum input for total higher harmonic distortion factor < 0.5%	2.6	2.8		Vrms
Output offset voltage	V _{OFFL}	24	L _{OUT} pin DC difference during SW switching		0	±15	mV
Input impedance	Z _{IL}			42	60	78	kΩ
Output impedance	Z _{OL}				120		Ω
R_{OUT} output							
Voltage gain	G _{R1}	TP5	b7=0, Sine wave, 2.5V _{P-P} , 1kHz	-6.5	-6.0	-5.5	dB
	G _{R2}	TP5	b7=1, Sine wave, 2.5V _{P-P} , 1kHz	-0.5	0	-0.5	
Frequency characteristics	F _R	TP5	Sine wave, 2.5V _{P-P} , 1MHz/1kHz	-3.0	0	1.0	dB
Total higher harmonic distortion	THDR	TP5	Sine wave, 2.5V _{P-P} , 1kHz		0.03	0.1	%
Input dynamic range	D _R	SG7	Sine wave, 1kHz Maximum input for total higher harmonic distortion factor < 0.5%	2.6	2.8		Vrms
Output offset voltage	V _{OFFR}	23	R _{OUT} pin DC difference during switching		0	±15	mV
Input impedance	Z _{IR}			42	60	78	kΩ
Output impedance	Z _{OR}				120		Ω
Crosstalk							
V _{OUT}	C _{TV}	TP1	Measurement Circuit Figure 2 SG1 input : 4.43MHz, 1V _{P-P} SG2 input : 4.43MHz, 0.5V _{P-P}		-60	-53	dB
Y _{OUT}	C _{TY}	TP2			-60	-53	dB
C _{OUT}	C _{TC}	TP3			-60	-53	dB
L _{OUT}	C _{TL}	TP4	Measurement Circuit Figure 2 1kHz, 2.5V _{P-P}		-90	-80	dB
R _{OUT}	C _{TR}	TP5			-90	-80	dB
Video I/O Pin Voltage							
Input pin voltage	V _{VIP}		No signal, no load	4.0	4.3	4.6	V
Output pin voltage	V _{VOP}		V _{OUT} pin, No signal, no load	4.1	4.4	4.7	V
	V _{SOP}		Y _{OUT} pin, C _{OUT} pin, No signal, no load	3.3	3.6	3.9	V
Audio I/O Pin Voltage							
Input pin voltage	V _{AIP}		No signal, no load	4.6	4.9	5.2	V
Output pin voltage	V _{AOP}		No signal, no load	3.9	4.2	4.5	V
Logic section (Refer to figure below)							
Input voltage L	V _{IL}		I ² C logic low level discrimination value	0.0		1.5	V
Input voltage H	V _{IH}		I ² C logic high level discrimination value	3.0		5.0	V
Low level output voltage (SDA)	V _{OL}		SDA for 3mA inflow	0.0		0.4	V
High level input current	I _{IH}		when SDA, SCL=4.5V impressed	-10		+10	μA
Low level input current	I _{IL}		when SDA, SCL=0.4V impressed	-10		+10	μA
Clock frequency	f _{SCL}					100	kHz
Data transmission waiting time	t _{BUF}			4.7			μs
SCL start hold time	t _{HD:STA}			4.0			μs
SCL low level hold time	t _{LOW}			4.7			μs
SCL high level hold time	t _{HIGH}			4.0			μs
SCL start set-up time	t _{SU:STA}			4.7			μs
SDA data hold time	t _{HD:DAT}			200			ns
SDA data set-up time	t _{SU:DAT}			250			ns
SCL rise time	t _R					1000	ns
SCL fall time	t _F					300	ns
SCL stop set-up time	t _{SU:STO}			4.0			μs

I²C BUS Control Signal

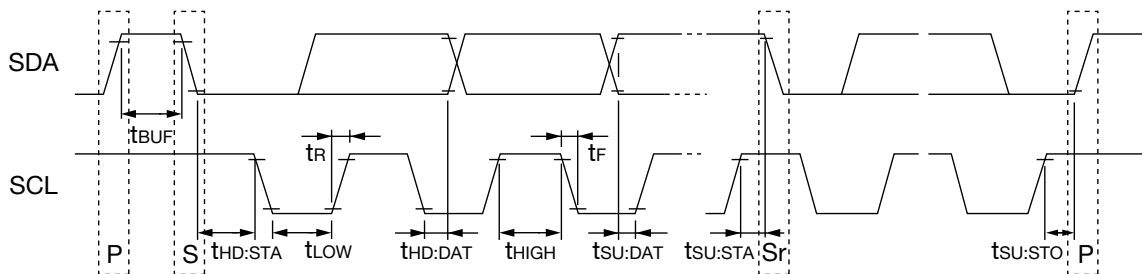

Measurement Circuit

■ Measurement Circuit 1

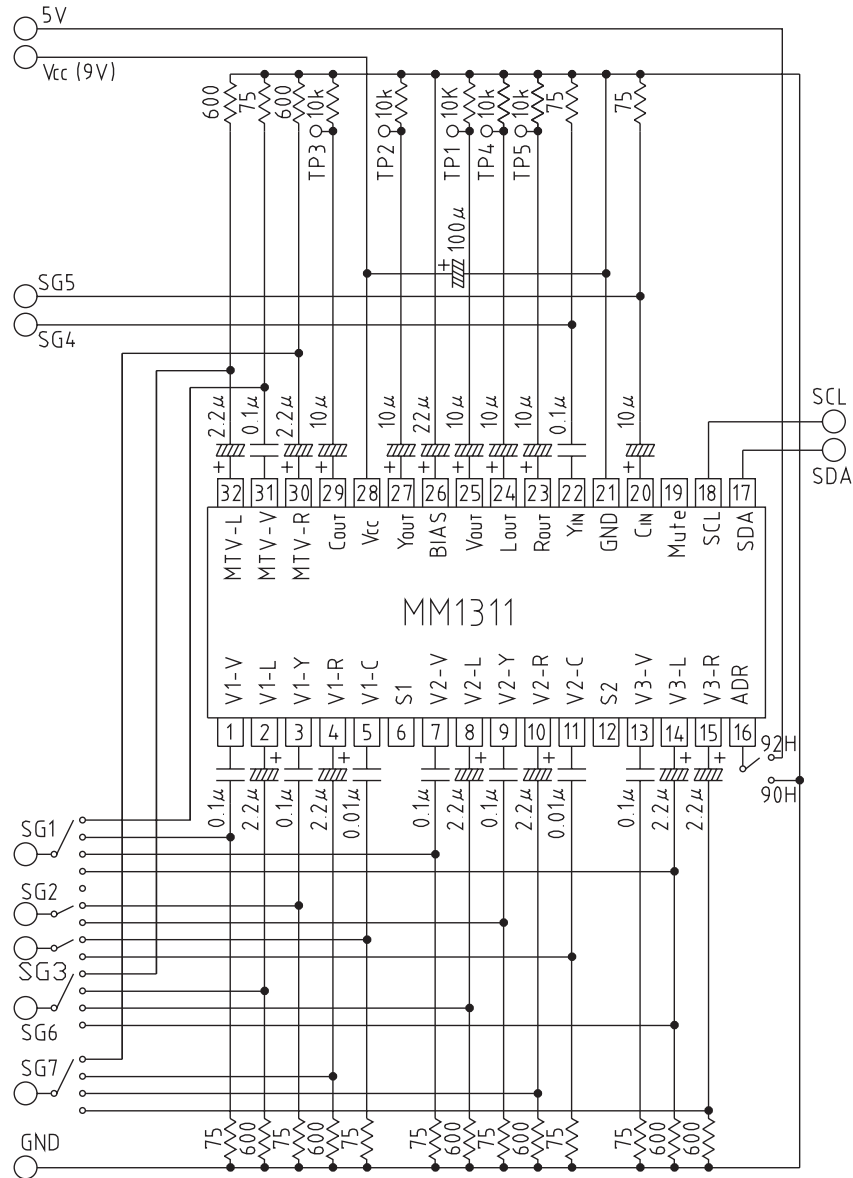

■ Measurement Circuit 2 (Crosstalk measurement)

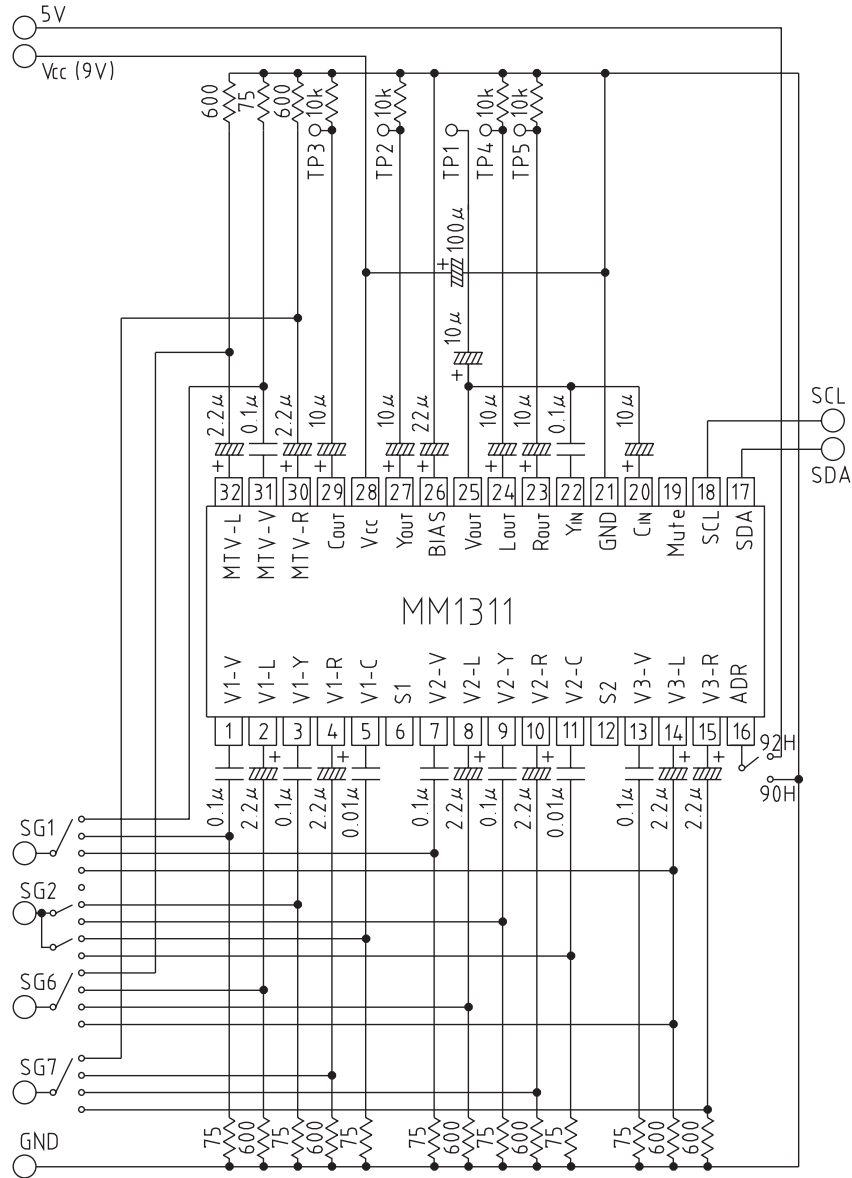

I²C BUS

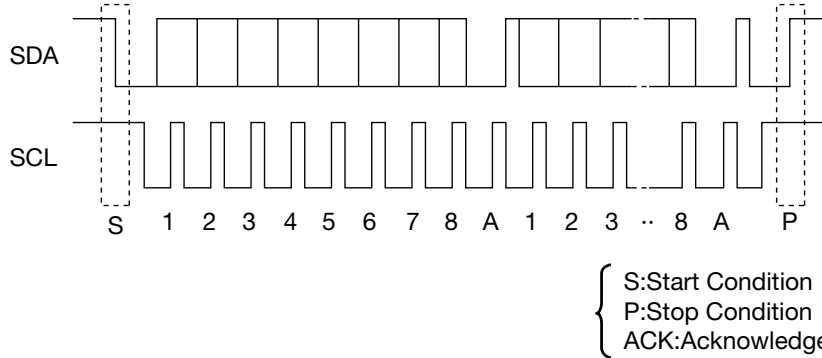

The I²C BUS is a BUS system developed by Philips for internal use in equipment. Data transmission is carried out by the two SDA and SCL lines, in byte units, with the MSB first from start condition.

Control Register

The control register contains data sent from the master in order to determine the status of each switch.

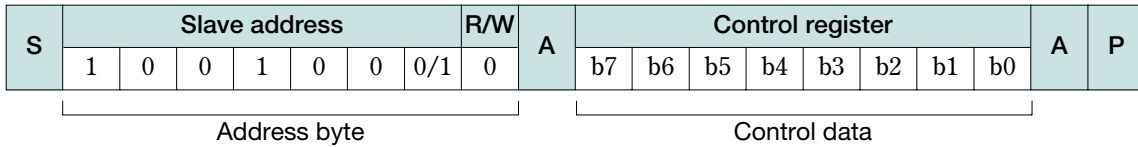

The data format is set as shown in the figure above. The first 7 bits in the address byte are allocated to the slave address, and the remaining 1 bit is allocated to the read/write bit. The read/write bit is set at 0 when using as a control register.

The MM1311 slave address can be selected as 90H/92H depending on the status of the ADR pin. When the ADR pin is low it is 90H. The relationship between the control register bits and switch control is as shown below.

b7	b6	b5	b4	b3	b2	b1	b0
Audio Gain	S/Comp Select	Video-Select			Audio-Select		

The control register bits are reset to 0 when power is applied.

MM1311 control is carried out by the 2-byte structure of the 1 address byte and 1 control data byte. All of the remaining data (third byte and after) are ignored.

Refer to the separate tables for details on switch control.

Status Register

The status register contains data for sending device status to the master.

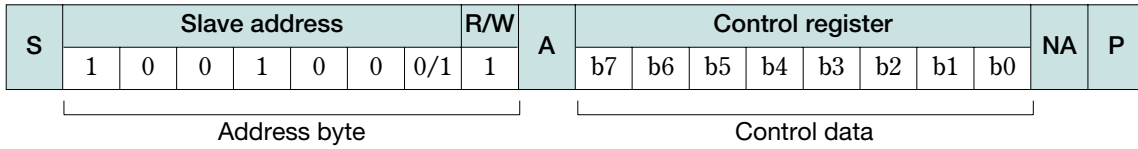

The data format is set as shown in the figure above. The first 7 bits in the address byte are allocated to the slave address, and the remaining 1 bit is allocated to the read/write bit. The read/write bit is set at 1 when using as a status register.

The MM1311 slave address can be selected as 91H/93H depending on the status of the ADR pin. When the ADR pin is low it is 91H. However, the confirmation response after completion of the status register should be non-acknowledge. The status register output data as shown below.

b7	b6	b5	b4	b3	b2	b1	b0
P-ON	×	S1	S1	S2	S2	×	×
RESET		OPEN	SEL	OPEN	SEL		

P-ON RESET : Returns 1 for power on reset. However once data read begins, 0 is returned next.
 S1/S2 OPEN : Returns 0 when the S1/S2 pin is not open, and returns 1 when the S1/S2 pin is open
 S1/S2 SEL : Returns 0 when the S1/S2 pin is not grounded, and returns 1 when the S1/S2 pin is grounded.

S1/S2 OPEN, SEL have 3-value discrimination, and the combinations are as shown below.

S1/S2 pin DC voltage	S1/S2 OPEN	S1/S2 SEL
0.8V or less	0	1
1.3V or more, 3.5V or less	0	0
4.5V or more	1	0

Power On Reset

Power on reset is built in to reset each control register to 0 when power is turned on.

Power on reset threshold has hysteresis as shown in the figure below. The IC power on reset status can be discriminated by reading the status register P-ON RESET.

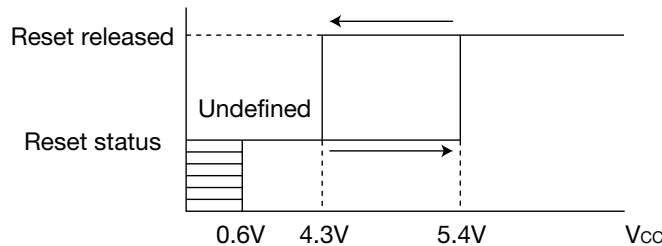

Switch Control Table

1. Video Output

b6	b5	b4	b3	V _{OUT}	Y _{OUT}	C _{OUT}
0	0	0	0	Mute	Mute	Mute
0	0	0	1	MTV-V	Y _{IN}	C _{IN}
0	0	1	0	V1-V	Y _{IN}	C _{IN}
0	0	1	1	V2-V	Y _{IN}	C _{IN}
0	1	0	0	V3-V	Y _{IN}	C _{IN}
0	1	0	1	Mute	Mute	Mute
		1	1			
1	0	0	0	Mute	Mute	Mute
1	0	0	1	MTV-V	Y _{IN}	C _{IN}
1	0	1	0	V1-Y+C	V1-Y	V1-C
1	0	1	1	V2-Y+C	V2-Y	V2-C
1	1	0	0	V3-V	Y _{IN}	C _{IN}
1	1	0	1	Mute	Mute	Mute
		1	1			

2. Audio Output

Mute pin	b2	b1	b0	L _{OUT}	R _{OUT}
1.5V or less (OPEN)	0	0	0	Mute	Mute
	0	0	1	MTV-L	MTV-R
	0	1	0	V1-L	V1-R
	0	1	1	V2-L	V2-R
	1	0	0	V3-L	V3-R
	1	0	1	Mute	Mute
1		1			
3.0V or more	—	—	—	Mute	Mute

3. Audio Gain Switching

b7	Output gain
0	-6dB output
1	0dB output

Example of Application Circuit

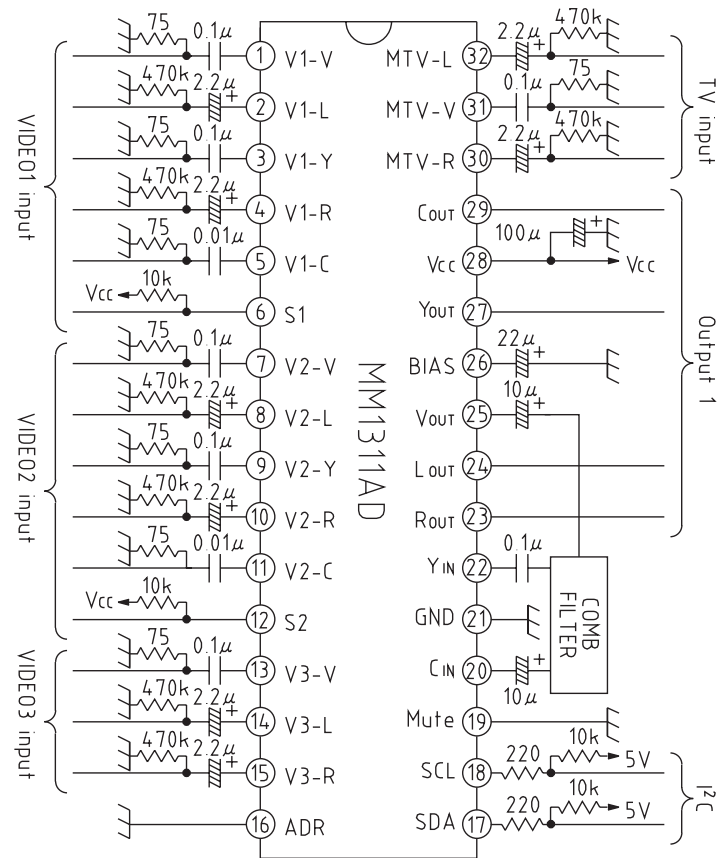

Notes 1 : V_{OUT} is set at 4.4V and C_{IN} at 4.3V.

Please note that capacitance polarity may vary depending on comb filter bias.

Notes 2 : Each audio output can be muted by making pin 19 high. Mute is off when it is open or low.