

### POWER MANAGEMENT

#### Description

The SC802 is a fully integrated, single cell, constant-current/constant-voltage Lithium-Ion/Lithium Polymer battery charger. With an integrated timer and complete charge control algorithm, the SC802 is well suited for stand-alone charger applications. The SC802 contains programmable pre-charge, fast-charge, and termination current settings. The SC802 can be programmed to terminate charge based on the output current or the time-out of the programmable timer. The fast charge current is typically set with an external resistor but can be modified with the analog fast charge input to allow a Power Management Controller to control the fastcharge current setting via DAC.

The 14V input voltage range of the SC802 eliminates additional protection circuitry required by other 5V chargers in the event of faulty adapters.

Reference ground and battery sense inputs are provided to allow Kelvin connections to eliminate IR voltage drops during charging.

The output voltage to the battery is controlled to within 1% of the programmed voltage for either 4.1V or 4.2V. The SC802 can also function as a general purpose current source or as a current source for charging nickel-cadmium (NiCd) and nickel-metal-hydride (NiMH) batteries using NTC termination.

The SC802A version of the device is optimized for high termination current applications. All descriptions and text referring to the SC802 also apply to the SC802A unless otherwise noted.

#### Typical Application Circuit

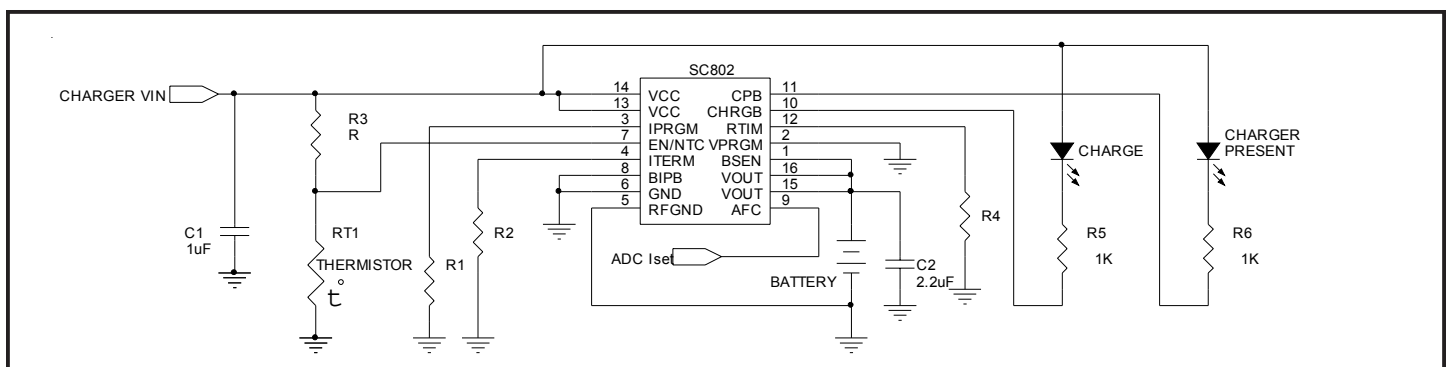

#### Features

- ◆ Fully integrated charger with FET pass transistor, reverse-blocking diode, sense resistor, timer, and thermal protection
- ◆ Complete voltage ranges of 4.1V, 4.2V & adjustable
- ◆ Programmable precharge, fastcharge & termination current
- ◆ Battery voltage controlled to 1% accuracy
- ◆ Soft-start for glitch-free adaptor plug-in
- ◆ Up to 1A continuous charge current
- ◆ Charge current monitor output for microcontroller or ADC interface
- ◆ Input voltage range from 4.3V to 14V
- ◆ 0.1µA battery drain current in shutdown and monitor modes
- ◆ Operates without a battery in regulated LDO mode
- ◆ Small 4mm x 4mm 16 lead MLP package
- ◆ NTC thermistor sense input
- ◆ Adjustable 6 Hour programmable charge timer
- ◆ Over current protection in all charging modes
- ◆ Over voltage protection
- ◆ Remote Kelvin sensing at the battery terminals
- ◆ ADC input control capable
- ◆ Status output communicates charging and end of charge cycle
- ◆ Charges Li-Ion, Li-Polymer, NiCd and NiMH Batteries

#### Applications

- ◆ Cellular phones
- ◆ PDA's
- ◆ Handheld meters
- ◆ Charging stations
- ◆ Handheld computers
- ◆ Digital cameras
- ◆ Programmable current source

**POWER MANAGEMENT**
**Absolute Maximum Ratings**

Exceeding the specifications below may result in permanent damage to the device, or device malfunction. Operation outside of the parameters specified in the Electrical Characteristics section is not implied.

Pin Combination	Symbol	Maximum	Units
VCC, EN to GND		-0.3 to 14.0	V
VOUT, Rtime, AFC, VPRGM, IPRGM, CPB, CHRGB, ITERM, BIPB, to GND		-0.3 to +6.0	V
REFGND to GND		-0.3 to 0.3	V
Power Dissipation MLP (Derate 20mW/ °C above 85°C)	Pd	2	W
Thermal Impedance, Junction to Ambient	T <sub>JA</sub>	50*	°C/W
Thermal Impedance, Junction to Case	T <sub>JC</sub>	3	°C/W
Junction Temperature	T <sub>J</sub>	150	°C
Operating Ambient Temperature Range	T <sub>A</sub>	-40 to +85	°C
Peak IR Reflow temperature, soldering 20s-40s	T <sub>LEAD</sub>	260	°C
Storage Temperature Range	T <sub>STG</sub>	-65 to 150	°C
VOUT short to GND		Continuous	

\* Tied to PCB with 1 Square Inch, 2 Ounce Copper, using JE5D 51 Standard.

**Electrical Characteristics**

Unless otherwise noted: VCC = 4.75V - 5.25V

Parameter	Symbol	Conditions	25°C			T <sub>A</sub> (-40°C to +85°C)		Units
			Min	Typ	Max	Min	Max	
Input Withstand Voltage	VCC					4.3	14	V
Operating Voltage	VOP					4.3	6.5*	V
VCC UVLO Rising Threshold	VT <sub>UVLOR</sub>			4.0		3.7	4.3	V
VCC UVLO Hysteresis	VT <sub>UVLOH</sub>	VCC Falling Hysteresis		40				mV
VCC OVP Rising Threshold	VT <sub>OVP</sub>			6.8		6.5	7.5	V
VCC OVP Falling Threshold	VT <sub>OVPF</sub>			6.5		6.1	7.1	V
VCC OVP Hysteresis	VT <sub>OVPH</sub>	VCC Falling Hysteresis		300		200	500	mV
Operating Current	ICC <sub>DIS</sub>	Shutdown Mode CHRGB, CPB off		2.6				mA
	ICC <sub>CHG</sub>	Charging Mode CHRGB, CPB off		2.4		1	3.5	
	ICC <sub>LDO</sub>	LDO Mode CHRGB, CPB off		16		8	23	

\* Maximum Vsupply as defined in EIA/JEDEC Standard No. 78, paragraph 2.11.

**POWER MANAGEMENT**
**Electrical Characteristics (Cont.)**

Unless otherwise noted: VCC = 4.75V - 5.25V

Parameter	Symbol	Conditions	25°C			T <sub>A</sub> (-40°C to +85°C)		Units
			Min	Typ	Max	Min	Max	
Battery Leakage Current (Vout and BSEN)	I <sub>Leak_BAT</sub>	VCC = 0V, VOUT = BSEN = 4.5V		0.1			2	μA
Regulated Voltage	V <sub>BAT2</sub> V <sub>BAT1</sub>	VPRGM = Logic High VPRGM = Logic Low		4.20 4.10		4.16 4.06	4.24 4.14	V
Adjust Mode Feedback Voltage	V <sub>ADJMF</sub>	VPRGM = External Divider VCC = 4.2V - 6.5V		3.0				V
Adj Mode VPRGM Shunt Resistance	R <sub>VPGMSH</sub>	Adjust Mode V <sub>VPRGM</sub> = 0.1V		1		0.5	5	kΩ
REFGND Output Accuracy Vout = Voutnom + Drefgnd	V <sub>REFGND</sub>	Refgnd - Agnd = 30mV		30		22	38	mV
REFGND Current	I <sub>REFGND</sub>	Refgnd = 0V		35				μA
SC802 Pre-Charge Current	I <sub>PREQ</sub>	SC802 Rterm = 3.01kΩ		82		74	90	mA
SC802 Termination Current	I <sub>TERMQ</sub>	SC802 Rterm = 3.01kΩ		42		35.5	49.5	mA
SC802 Fast-Charge Current	I <sub>FastQ</sub>	IPRGM = 3.01kΩ VBATTERY = 3.8V		500		450	550	mA
SC802 AFC DAC Fast-Charge Current	I <sub>DACADJ</sub>	IPRGM = 3.01kΩ V(AFC) = 0.75V		240		200	280	mA
SC802A Pre-Charge Current	I <sub>PREQA</sub>	SC802A Rterm = 976Ω		145		135	160	mA
SC802A Termination Current	I <sub>TERMQA</sub>	SC802A Rterm = 976Ω		145		135	160	mA
SC802A Fast-Charge Current	I <sub>FastQA</sub>	IPRGM = 1.78kΩ VBATTERY = 3.8V Rterm = 976Ω		800		740	860	mA
SC802A AFC DAC Fast-Charge Current	I <sub>DACADJA</sub>	IPRGM = 1.78kΩ V <sub>AFC</sub> = 0.75V VBATTERY = 3.8V Rterm = 976Ω		367		310	430	mA
I <sub>PROG</sub> Regulated Voltage	V <sub>IPRGM</sub>			1.5		1.4	1.6	V
Adjust Mode Threshold Voltage	V <sub>T_ADJM</sub>	Vout - BSEN Voltage		250		50	420	mV
V <sub>BAT</sub> Precharge Threshold	V <sub>T_PreQ</sub>			2.8		2.7	2.9	V
V <sub>BAT</sub> Recharge Threshold	V <sub>T_ReQ</sub>	VBAT - VBATTERY		100		70	140	mV
Over Temperature Shutdown	TP <sub>OT</sub>	Hysteresis = 10 °C		150				°C

**POWER MANAGEMENT**
**Electrical Characteristics (Cont.)**

Unless otherwise noted: VCC = 4.75V - 5.25V

Parameter	Symbol	Conditions	25°C			T <sub>A</sub> (-40°C to +85°C)		Units
			Min	Typ	Max	Min	Max	
EN-NTC Thresholds	V <sub>T<sub>NTCDIS</sub></sub>	SC802 Disable		<1		0.5	1.1	V
	V <sub>T<sub>NTCH</sub></sub>	NTC Hot Vth, VCC = 5V	1.41	1.5	1.59	1.4	1.6	V
			28.2	30	31.8	28	32	%
	V <sub>T<sub>NTCC</sub></sub>	NTC Cold Vth, VCC = 5V	3.62	3.75	3.88	3.6	3.9	V
			72.4	75	77.6	72	78	%
	V <sub>T<sub>NTCEN</sub></sub>	NTC Enable, VCC = 5V	4.22	4.5	4.58	4.2	4.6	V
84.4			90	91.6	84	92	%	
V <sub>T<sub>NTHYS</sub></sub>	Hot/Cold Vth hysteresis		50				mV	
Timer Disable Threshold	V <sub>T<sub>TIMER</sub></sub>	V <sub>RTIME</sub> < V <sub>T<sub>TIMER</sub></sub> Disables Timer		1		0.7	1.1	V
Internal Timer Select	V <sub>T<sub>INTTS</sub></sub>	VCC - V <sub>RTIME</sub> < V <sub>T<sub>INTTS</sub></sub> selects internal timer		1.5				V
Ext RTIME Voltage	V <sub>RTIME</sub>	RTIME tied through 36.5kΩ to GND		1.5		1.4	1.6	V
Pre-Charge Fault Time-out	T <sub>PreQF</sub>	RTIME tied through 36.5kΩ to GND RTIME tied to VCC		50				min
				45		-35%	+35%	
Complete Charge Time-out	T <sub>QCOMP</sub>	RTIME tied through 36.5kΩ to GND RTIME tied to VCC		3.3				hr
				3		-35%	+35%	
CHRGB Charge LED On	V <sub>CHRGB</sub>	Load = 5mA		0.5			1	V
CHRGB Charge LED Off	I <sub>CHRGB</sub>	Leakage Current, V = 5V					1	μA
CPB LED On	V <sub>CPB</sub>	Load = 5mA		0.5			1	V
CPB LED Off	I <sub>CPB</sub>	Leakage Current, V = 5V					1	μA
BIPB, VPRGM Inputs	V <sub>IH</sub>					1.8		V
	V <sub>IL</sub>						0.4	V

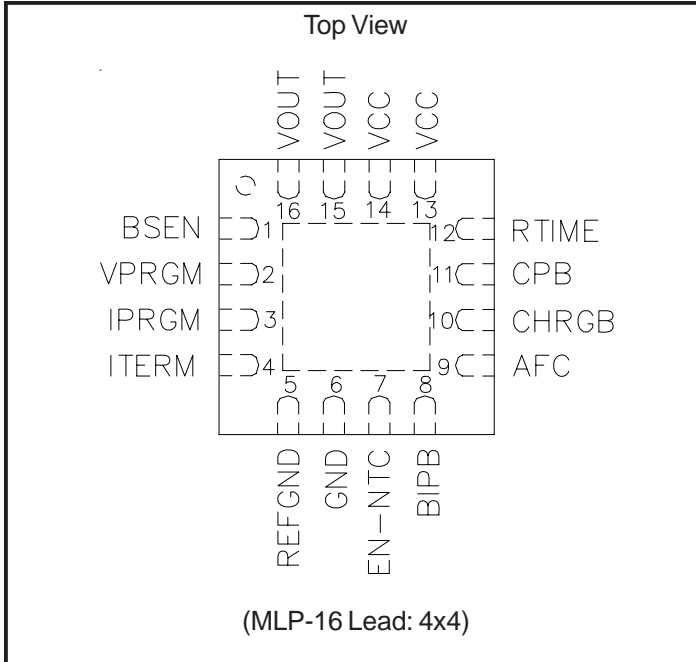
**POWER MANAGEMENT**
**Pin Configuration**

**Ordering Information**

DEVICE <sup>(1)</sup>	PACKAGE
SC802IMLTR	MLP-16
SC802IMLTRT <sup>(2)</sup>	MLP-16
SC802AIMLTRT <sup>(2)</sup>	MLP-16
SC802EV <sup>(3)</sup>	Evaluation Board

**Note:**

(1) Only available in tape and reel packaging. A reel contains 3,000 devices.

(2) TRT extension designates the lead-free leadframe package option. This product is fully WEEE and RoHS compliant.

(3) Specify the desired IC part number when ordering.

**Pin Descriptions**

Pin #	Pin Name	Pin Function
1	BSEN	Battery voltage sense pin. Connect to battery terminal to Kelvin sense battery voltage. Do not leave this pin floating.
2	VPRGM	Selectable voltage program pin. Logic low = 4.1V. Logic high = 4.2V. Resistor = adjustable.
3	IPRGM	Charger current program pin in fast charge mode. Requires a resistor to ground to program fast-charge current.
4	ITERM	Selection for current termination and pre-charge current. Requires a resistor to ground to program pre-charge and termination current.
5	REFGND	Reference Ground. Allows Kelvin connection to battery negative terminal.
6	GND	Ground
7	EN-NTC	Combined Device enable/disable and NTC input pin. Logic high enables device. Logic low disables device. Analog voltages between 0.3VCC and 0.75VCC enable the NTC function.
8	BIPB	Battery in Place Bar (BIPB) selects Charge/LDO mode. BIPB=Low selects charge mode. BIPB=High selects LDO mode which disables Pre-Charge and timer-out functions
9	AFC	Analog Fast Charge Setting. Connect to DAC for analog control of fast charge current value. Connect to VCC to disable AFC. Do not leave open.
10	CHRGB	Open Drain Charger Status Pin. The output is active low when the Charger is on and the output current exceeds the termination current value. The output switches to high impedance when $I_{out} < I_{termination}$ . This pin can sink 10mA.
11	CPB	Open Drain Charger present indicator. The output is active low when the VCC exceeds UVLO. This pin can sink 10mA.

**POWER MANAGEMENT**
**Pin Descriptions (Cont.)**

Pin #	Pin Name	Pin Function
12	RTIME	Programable timer input pin. Connect to VCC to select the internal time-out of 3hrs, connect to ground to disable the timer. Connect an external resistor to ground to program the timeout period.
13	VCC	Supply pin, connect to adaptor power.
14	VCC	Supply pin, connect to adaptor power.
15	VOUT	Charger output, connect to battery.
16	VOUT	Charger output, connect to battery.
T	Thermal Pad	Pad for heatsinking purposes. Connect to ground plane using multiple vias. Not connected internally.

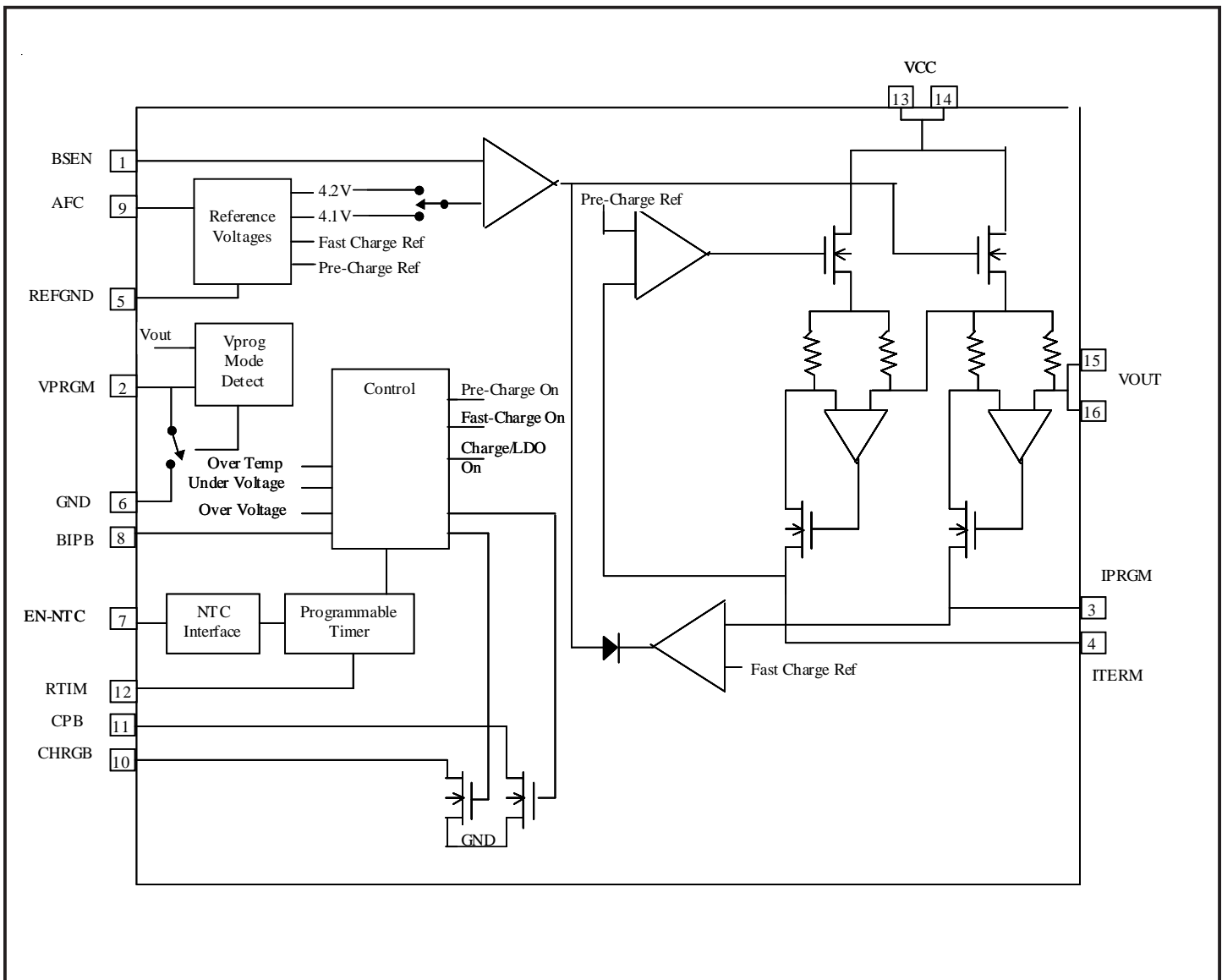
**Block Diagram**

**POWER MANAGEMENT**
**Applications Information**
**General Operation**

The SC802 is configured based on the application for Fast Charge and Termination current, output voltage, timing requirements, and operation with and without a battery (I<sub>do</sub> mode). A typical charging cycle is described below. Details on alternate applications and output programmability are covered in the individual sections.

The charging cycle begins when the adapter is plugged in. The SC802 performs glitch filtering on the VCC input and initiates a charge cycle when VCC > UVLO. At this time, the CPB and CHRGB signals are active turning on the charger LED's. If the battery voltage is less than 2.8V, the SC802 will charge the output with the pre-charge current. When the battery voltage exceeds 2.8V, the SC802 enters fast-charge or constant current (CC) mode. When the battery voltage reaches its final value, the charger enters the constant voltage (CV) mode. In this mode the output current decreases as the battery continues to charge until the termination current level is reached.

The CHRGB led turns off when I<sub>out</sub> is less than I<sub>termination</sub> but the SC802 continues to hold the battery in CV charge mode until the timer expires. At this point the charger enters the monitor mode where the output remains off until V<sub>out</sub> drops by 100mV and a new charge cycle is initiated.

**Pre-Charge Mode**

Pre-charge mode is automatically enabled whenever the battery voltage is below 2.8V. It is used to limit the power dissipation and precondition the battery for fast charging. The pre-charge current value is selected by the resistor on the ITERM pin. The pre-charge current is programmable from 10mA to 125mA on the SC802 and up to 150mA on the SC802A. The equation to select the pre-charge current is different for the two part types and given by:

$$\text{SC802 : PCI} = \left( \frac{2.8}{R_{\text{TERM}}} \right) \times 88$$

$$\text{SC802A : PCI} = \left( \frac{1.5}{R_{\text{TERM}}} \right) \times 97$$

If the charge timer is in use there is also a maximum allowed pre-charge duration. If the pre-charge time ex-

ceeds 1/4 of the total charge cycle the charger will turn off due to a pre-charge fault. This fault is cleared when EN or VCC is toggled or the output voltage rises above 2.8V.

**Fast-Charge Mode (CC)**

The fast-charge or CC mode is active when the battery voltage is above 2.8V and less than the CV or final float charge voltage of the battery. The fast-charge current can be set to a maximum of 1.0A and is selected by the program resistor on the IPRGM pin. The voltage on this pin will represent the current through the battery enabling a microprocessor via an analog-to-digital converter (ADC) to monitor battery current by sensing the voltage on the IPRGM pin. The equation to set the fast-charge current is given by:

$$\text{SC802 : FCI} = \left( \frac{1.5}{R_{\text{PRGM}}} \right) \times 1000$$

$$\text{SC802A : FCI} = \left( \frac{1.5}{R_{\text{PRGM}}} \right) \times 1000 - 0.3 \times \text{Iterm}$$

Note that for a given program resistor the current through the battery in CV mode can be determined by replacing 1.5 with the actual voltage on the IPRGM pin in the above equation. The CC current can also be modified by applying an analog voltage to the AFC pin as described below.

**Analog Fast Charge (AFC Pin)**

Many applications require more than one current setting for Fast Charge. This feature is included in the SC802 by using the AFC function. When the AFC pin is connected to VCC the device behaves as described in the previous section. When the AFC pin is driven by an analog voltage between 0 and 1.5V the SC802 automatically uses this pin voltage to set the maximum fast-charge current setting according to the following equation.

$$\text{SC802 : AFCI} = \left( \frac{V_{\text{AFC}}}{R_{\text{PROG}}} \right) \times 1000$$

$$\text{SC802A : AFCI} = \left( \frac{V_{\text{AFC}}}{R_{\text{PROG}}} \right) \times 1000 - 0.3 \times \text{Iterm}$$

## POWER MANAGEMENT

### Applications Information Cont.

#### Termination Current

Once the battery reaches the program voltage of 4.1V, 4.2V or externally set voltage, the device will transition from a constant current source to a constant voltage source. The current through the battery begins to decrease while the voltage remains constant until it falls below the programmed termination current set by the termination resistor on the ITERM pin. The SC802 will turn off the CHRGB Led. If the timer is enabled the output will continue to float charge in CV mode until the timer expires. If the timer is disabled then the output will turn off as soon as the termination current level is reached. The equation for setting the the termination current

$$\text{SC802 : ITERM} = \left( \frac{1.5}{R_{\text{TERM}}} \right) \times 88$$

$$\text{SC802A : ITERM} = \left( \frac{1.5}{R_{\text{TERM}}} \right) \times 97$$

The termination current is programmable up to 67mA for the SC802. The termination current is programmable up to 150mA with VCC=5V on the SC802A.

#### Monitor Mode

When a charge cycle is completed, the SC802 output turns off and the device enters monitor mode. If the voltage of the battery falls below the recharge threshold of CV-100mV the charger will clear the charge timer and re-initiate a charge cycle. The maximum current drain of the battery during monitor mode will be no more than 1uA over temperature. The status of the charger output as a function of BIPB, Timer, and IOOUT is shown below.

Output State	BIPB	Timer	Iout
On	High	N/A	N/A
On	Low	T < Timer	N/A
Off	Low	T > Timer	N/A
Off	Low	Disabled	< Itermination

#### Charge Timer

The timer on the SC802 is used as protection in the case of a faulty battery and to maximize charging capacity. Tie the RTIM pin to VCC to select the internal timer, GND to disable the timer. Connecting a resistor between RTIM and GND will program the total charge time according to the following equation with the charge time expressed in hours.

$$\text{RTIM} = \text{Total Q Time} \times 12.5\text{k}\Omega$$

The timer is programmable over the range of 2 to 6hrs. The internal timer selection results in a charge time of 3hrs. The CHRGB blink rate in fault conditions is a function of the timer setting when an external RTIM is used.

The SC802 will automatically turn off the output when the charge timer times out.

#### LDO Mode

The SC802 is designed to work with or without a battery. If the battery is not in place the device can enter the LDO mode. In this mode the SC802 will act like a low dropout regulator. The output voltage is set to 4.1V, 4.2V or externally set by a resistor divider. See the section titled "Configuring the output voltage to the battery" for setting an output voltage. The input pin BIPB (Battery In Place Bar) is used to switch the SC802 from charger mode to LDO mode. If this pin is logic high the device will be in LDO mode, if it is logic low it will be in the charger mode. During LDO mode the device will regulate the output voltage with a current limit set by the resistor tied to the IPRGM pin. The BIPB pin should never be left floating. It should be tied through pull-up/pull-down resistors when connected to a high impedance control pin or it can be connected directly to the VCC pin or GND.

#### EN-NTC Interface

The Enable pin on the SC802 provides two functions. It can be used to turn on/off the device by driving it to VCC/Ground. It can also be connected to an external resistor divider consisting of a resistor and an NTC Thermistor to disable the charge cycle when the temperature is out of range. This configuration is shown in the typical application schematic on page 1 of the datasheet. When the NTC voltage from the divider is above or below the hot and cold temperature threshold values the SC802 will suspend the charge cycle by turning off the output, freezing the charge timer, and indicating a fault on the CHRGB LED. Hysteresis is included for both thresholds to avoid chatter at the NTC trip points. When the tem-



**POWER MANAGEMENT**
**Applications Information Cont.**

perature returns to the valid range the SC802 automatically resumes the charge cycle. The charge timer will time-out when the SC802 output on-time exceeds the timer setting regardless of how long it has been disabled due to temperature. The internal NTC thresholds of 30% and 75% VCC were designed to work with curve-2 type thermistors available from numerous vendors.

Design Example based on the typical application schematic of page 1 using a Curve 2 Vishay-Dale NTC.

Thot = 50°C  
Tcold = 0°C  
Find R3 and RT1

Step 1: Pick an RT1 value high enough to prevent self-heating.

$$RT1 \geq \frac{(V(RT1))^2}{DC}$$

In general lower values of RT1 provide more noise for the NTC voltage at the expense of bias current from the input adapter. The dissipation constant DC is the power rating of the NTC resulting in a 1°C self heating error.

The DC value for this NTC is 3mW and the voltage across the NTC is 2.5V for a 5V adapter. Therefore RT1 > 2k.

$$\text{Set } RT1 = 10k$$

Step 2: Find R3 to set the correct Hot level trip point

$$R3 = 2.33 \times \left( R_{T25} \times \left( \frac{R_{T50}}{R_{T25}} \right) \right) = 9.52k$$

The closest standard resistor value is 9.53k. RT(temp)/RT(25°C) is often referred to as the ratio at the given temp. For this NTC at 50°C the ratio is 0.4086.

Step 3: Calculate the Tcold value.

$$\left( \frac{RT_{COLD}}{RT_{25}} \right) = 3 \times \left( \frac{R3}{10k} \right) = 2.86$$

The ratio for the Curve 2 NTC at 0° is 2.816. The difference represents less than 1/2°C (ie actual trip would be -0.5°C instead of 0°C.) For temperature trip values other

than 0°C and 50°C alternate curve-type NTC elements can be used or an additional resistor can be added to the Rntc divider to alter the temperature coefficient.

**LED Flags**

There are two LED drivers on the SC802: CHRGB (Charge) and CPB (Charger Present). These outputs are open drain NMOS drivers for controlling LEDs directly. The Table below defines each LED output state.

LED FLAG	ON	OFF	Blinking
CPB	UVLO < VCC < OVP	Power Not Good	X
CHRGB	Iout > Iterm	Iout < Iterm*	PreCharge or NTC Fault

\* Output remains on when timer is enabled and t < timeout

The CPB output can be used for a VCC indicator. Regardless of the state of EN, the CPB output reflects the voltage of the VCC (adapter) input. When VCC is between the UVLO and OVP thresholds the CPB output is low.

The CHRGB output signifies the charging status. When the output current is > Itermination, CHRGB=low. CHRGB is high when Iout is < Itermination. The CHRGB output is latched during the charge cycle when the output current is less than Itermination. This latch is reset when the battery enters a re-charge cycle, or if BIPB, EN, or VCC are toggled. The CHRGB indicator operates the same way in both charge and Ido mode.

There are five fault modes detected by the SC802; (Input under voltage, input over voltage, NTC temperature, Max die temperature or OT and pre-charge timeout) The LED states for these fault modes are shown below.

Fault	CPB	CHRGB
VCC UVLO or VCC OVP	off	off
NTC Fault	on	Blinking
Pre-Charge Time-out	on	Blinking
Tj > 150C	off	off

## POWER MANAGEMENT

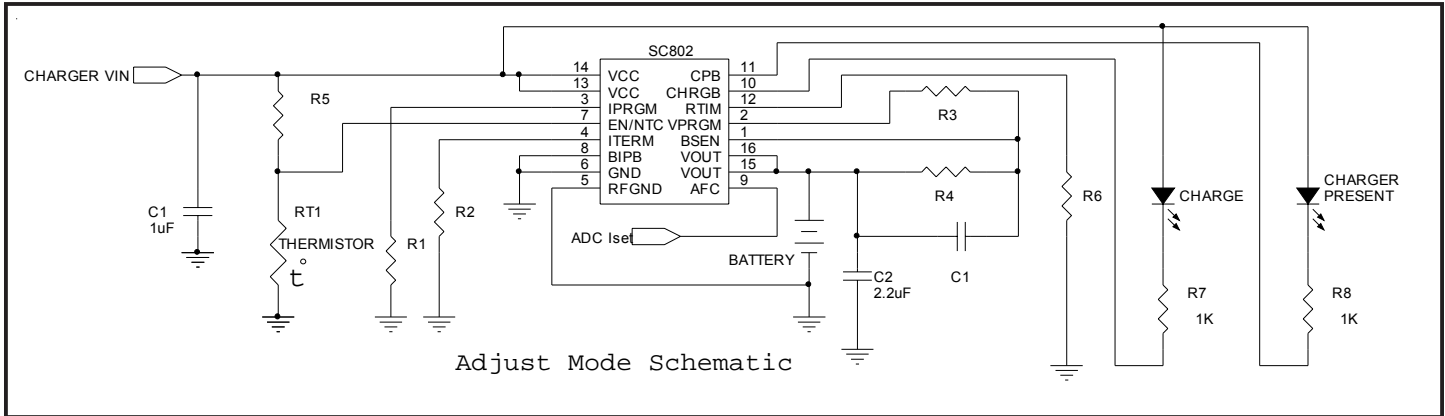

### Configuring the Output Voltage to the Battery Fixed Mode

The battery voltage is set by the VPRGM pin in fixed mode and externally in adjust mode. If VPRGM is logic high the output voltage is set to 4.2V. If this pin is logic low the output voltage will be set to 4.1V. For a value other than 4.1V or 4.2V a resistor divider is required.

### Adjust Mode

When the SC802 is configured with an output voltage other than 4.1 or 4.2V it is operating in adjust mode. In adjust mode the output voltage is set by an external resistor divider. The SC802 provides the ability to disconnect the external feedback resistor divider when the battery is not being charged to reduce current drain from the battery in normal operation. Connect the external resistor divider between the VOUT pin and the VPRGM pin with the divider tap connected to the BSEN pin to utilize this feature. The SC802 adjust mode schematic is shown above. The equation for setting the output voltage is:

$$V_{OUT} = \left(1 + \frac{R4}{R3}\right) \times 3.0$$

The capacitor across R4 in the feedback networks introduces zero-pole frequency compensation for stability. Place the zero according to the following equation to insure stability.

$$R4 \times C1 = \frac{1}{2\pi \times 100\text{kHz}}$$

When the SC802 is in Adjust mode the VCC is required to be 150mV > Vout. Internal protection circuits will disable the output if VOUT approaches VCC.

### Capacitor Selection

Input and output capacitors can be low cost ceramic type. The output capacitance range is 1uF to 4.7uF. The input capacitor is typically between 0.1uF to 1uF but larger values will not degrade performance.

### Overcurrent and Max Temperature Protection

Overcurrent protection is inherent in all modes of operation. When the device is in charge-mode (BIPB=low) the output is current limited to either the pre-charge current limit value or the fast charge current limit value depending on the voltage at the output. When the device is in LDO mode (BIPB=high) the output current is limited to the fast charge current limit. Max die temperature protection is included on the SC802. This feature allows the SC802 to operate with maximum power dissipation by disabling the output current when the die temperature reaches OT. The result is that the SC802 will operate as a pulse charger in extreme power dissipation applications delivering the maximum allowable output current while regulating the internal die temperature to a safe level.

### Remote Kelvin Sensing at the Battery

Kelvin sensing of both the positive and negative terminals of the battery is possible with the SC802. The BSEN pin provides the positive sensing voltage feedback to the CV amplifier and should be connected as close to the battery + terminal as possible. Likewise the REFGND pin should be kelvin connected to the negative terminal of the battery. This allows the designer great flexibility in PCB layout and achieves a much greater accuracy in sensing the battery voltage where it counts, at the battery terminals! Therefore, when laying out the PCB the designer should route the BSEN pin directly to the terminal at which the battery gets connected. In the LDO mode, the BSEN pin will still need to sense the output voltage; therefore BSEN should never be left floating.

POWER MANAGEMENT

State Diagram

Over Voltage, Under Voltage, or Over Temperature will force the SC802 into Shutdown Mode from any state.

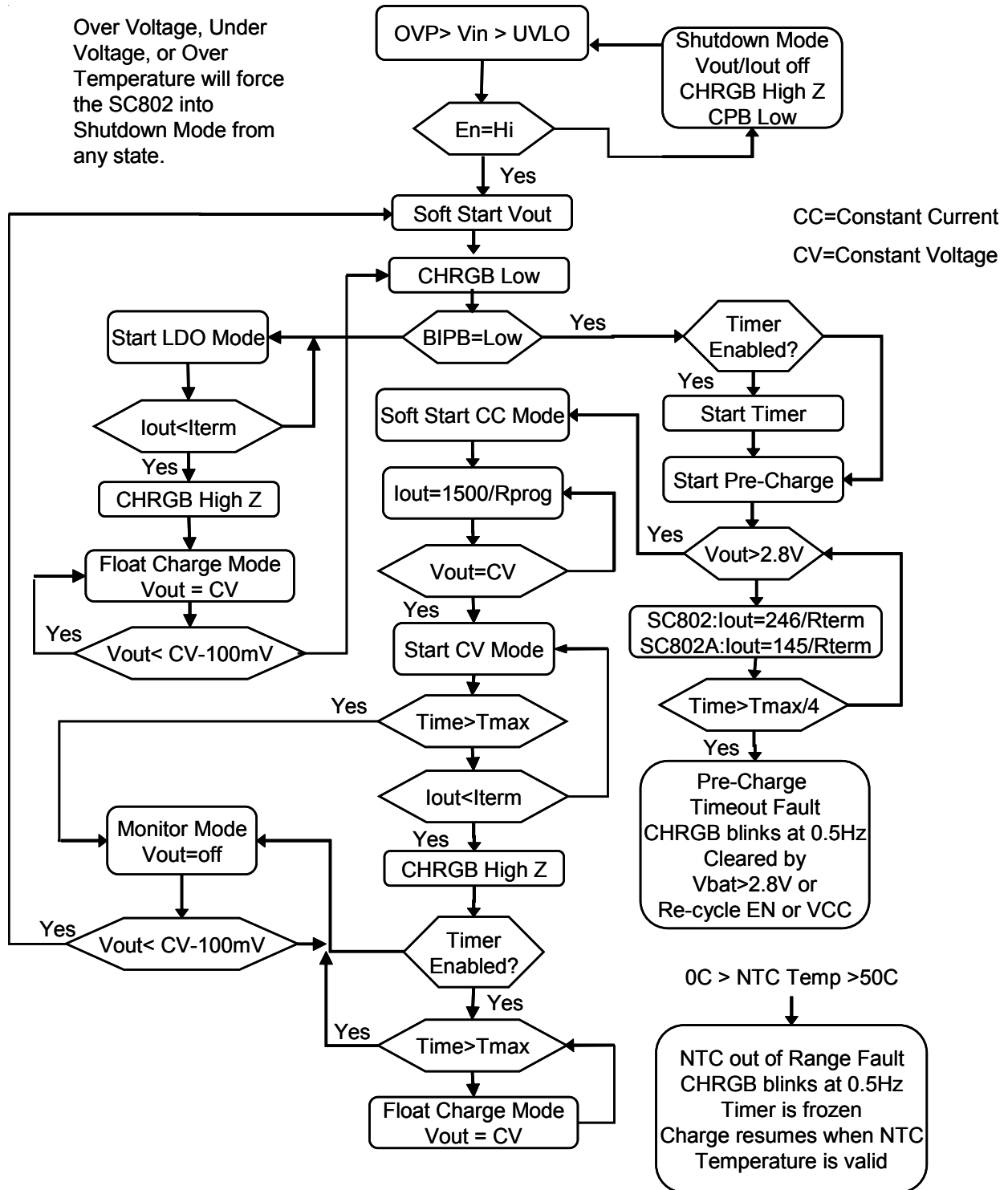

## POWER MANAGEMENT

### Evaluation Board Schematic

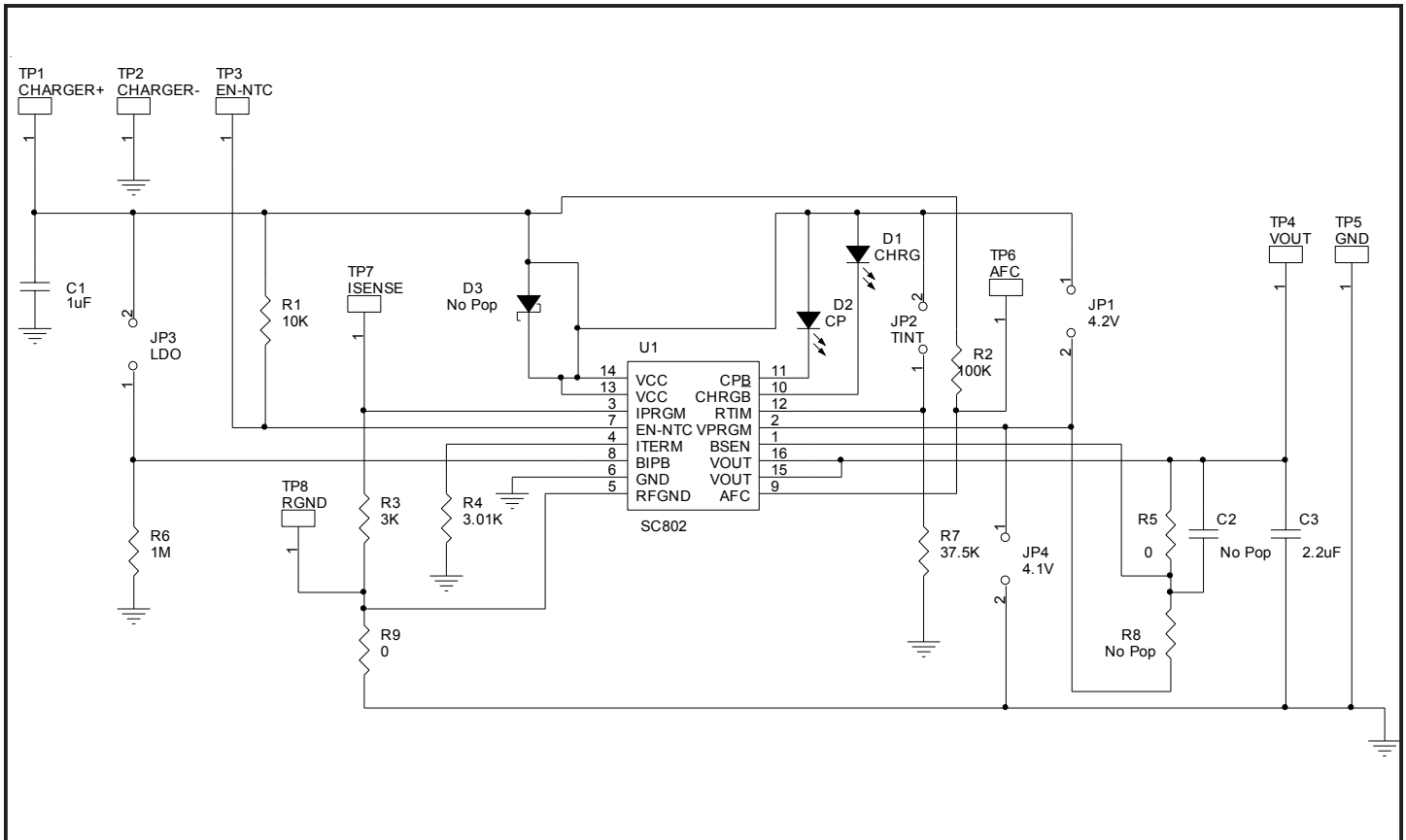

### Marking Information

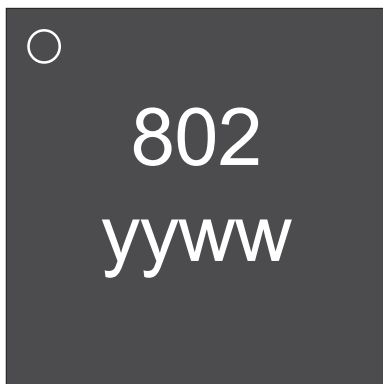

Top view.

Marking for the SC802 MLP 16 Lead package: yyww =  
Date Code (Example: 0012)

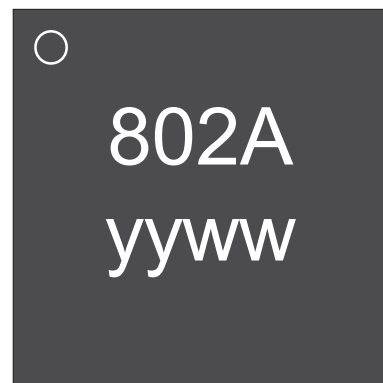

**POWER MANAGEMENT**

**Typical Characteristics**

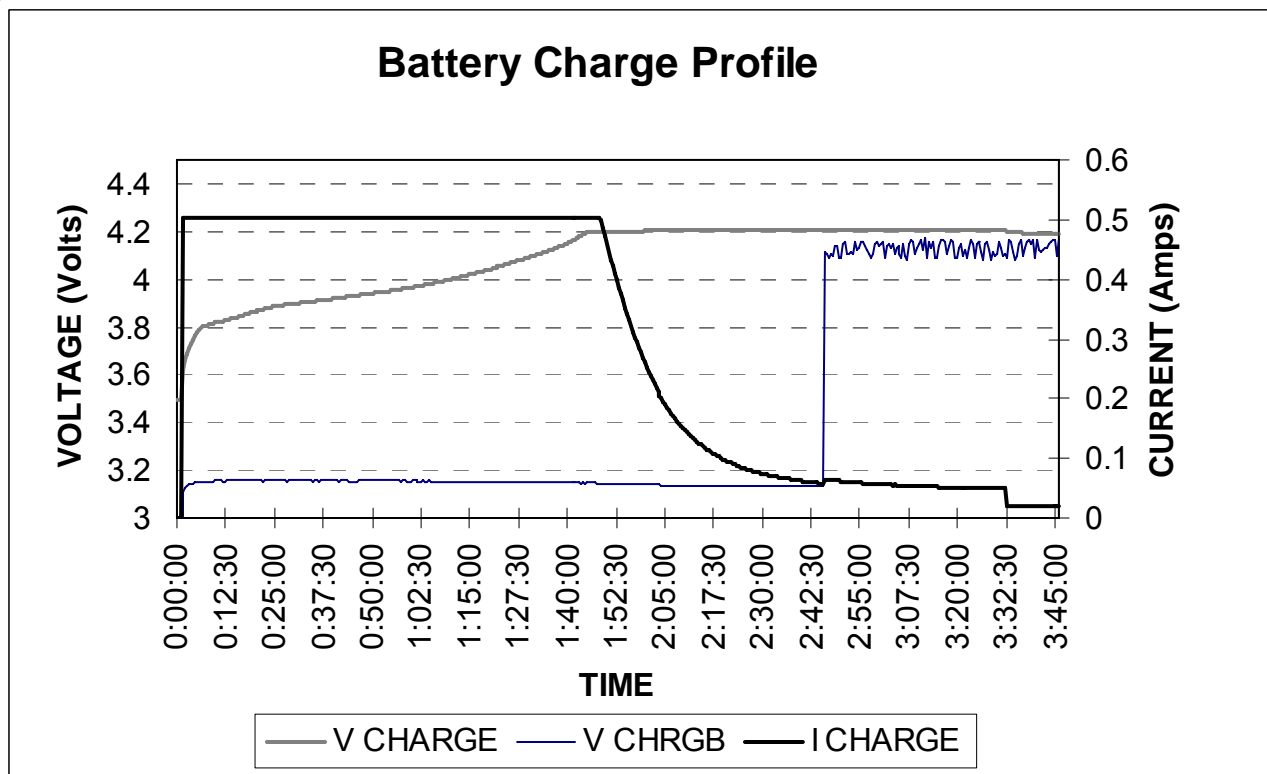
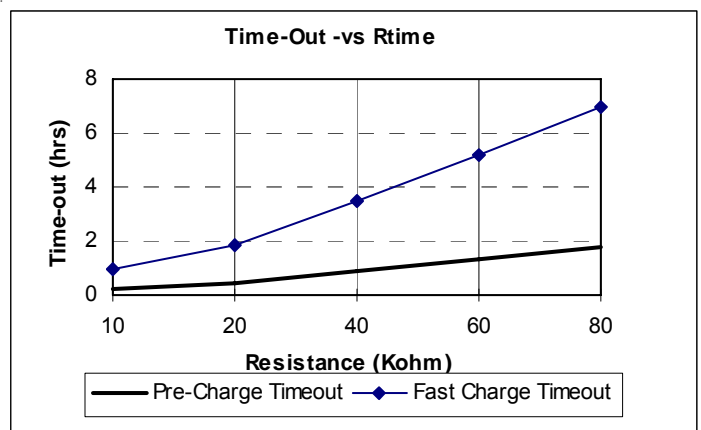
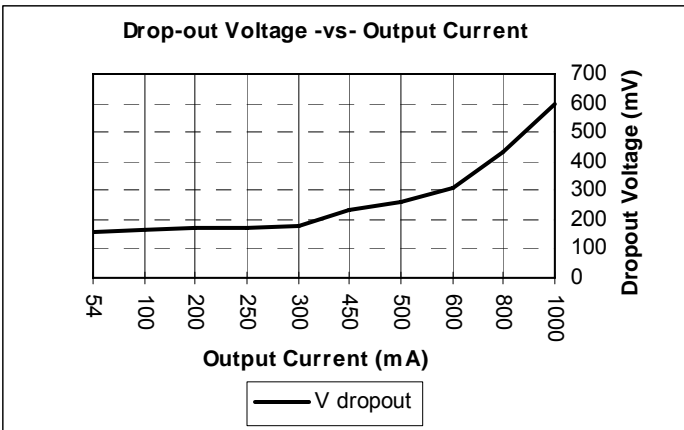
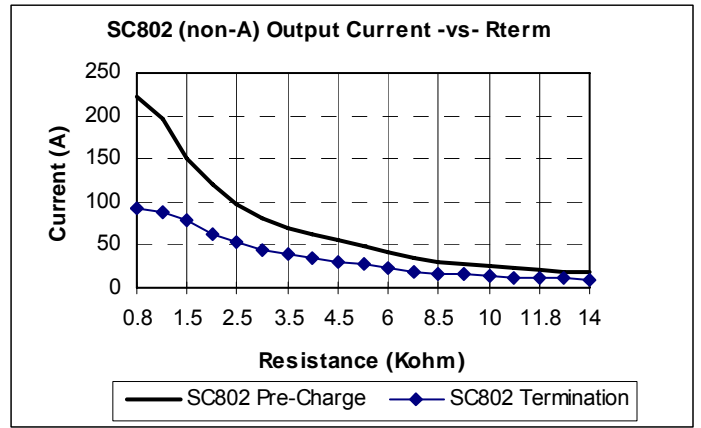
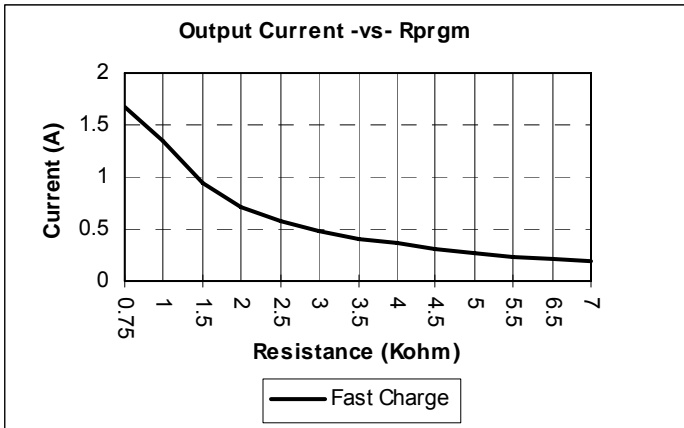

**POWER MANAGEMENT**

**Charge Mode Timing Diagram**

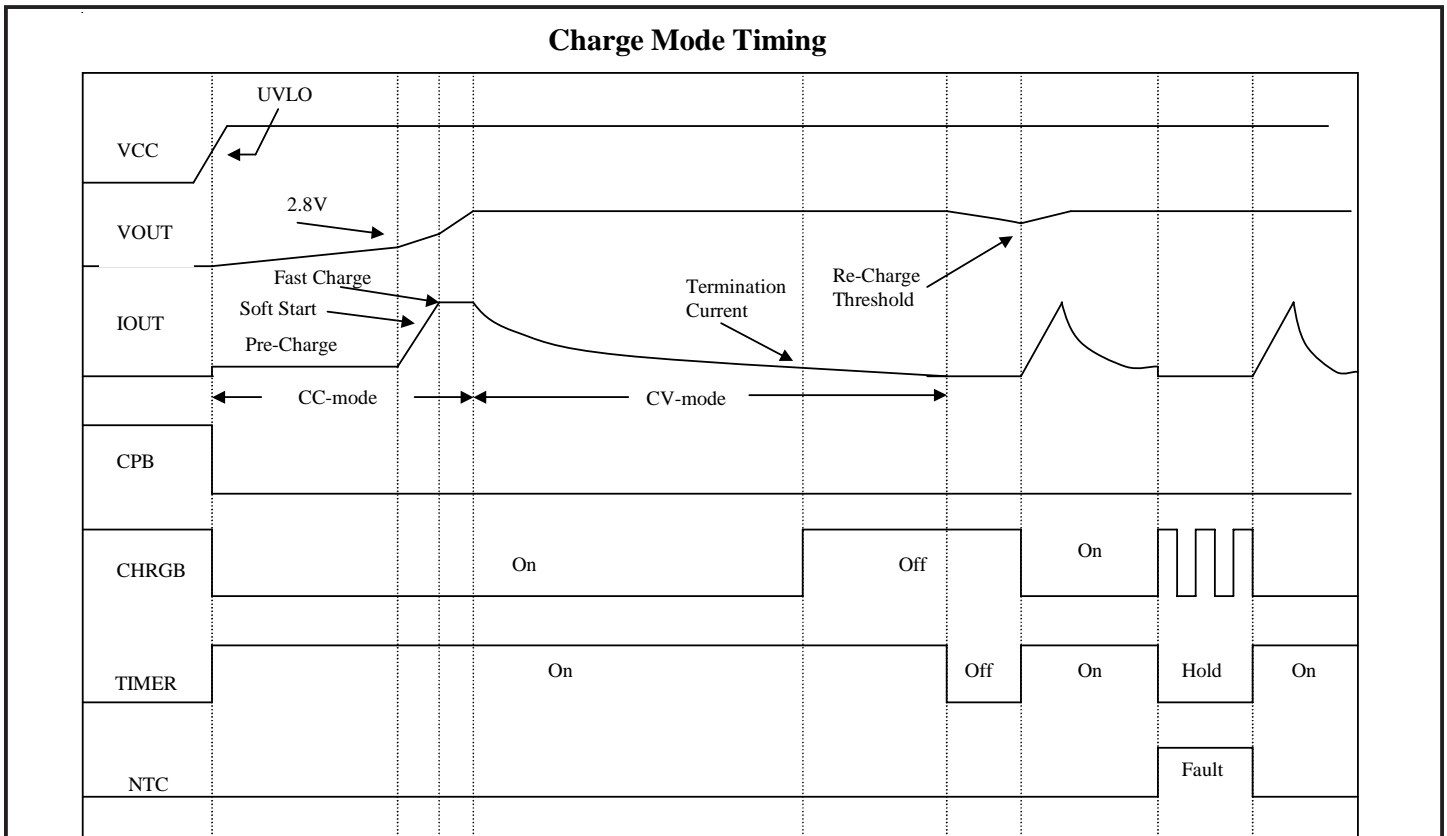

**LDO Mode Timing Diagram**

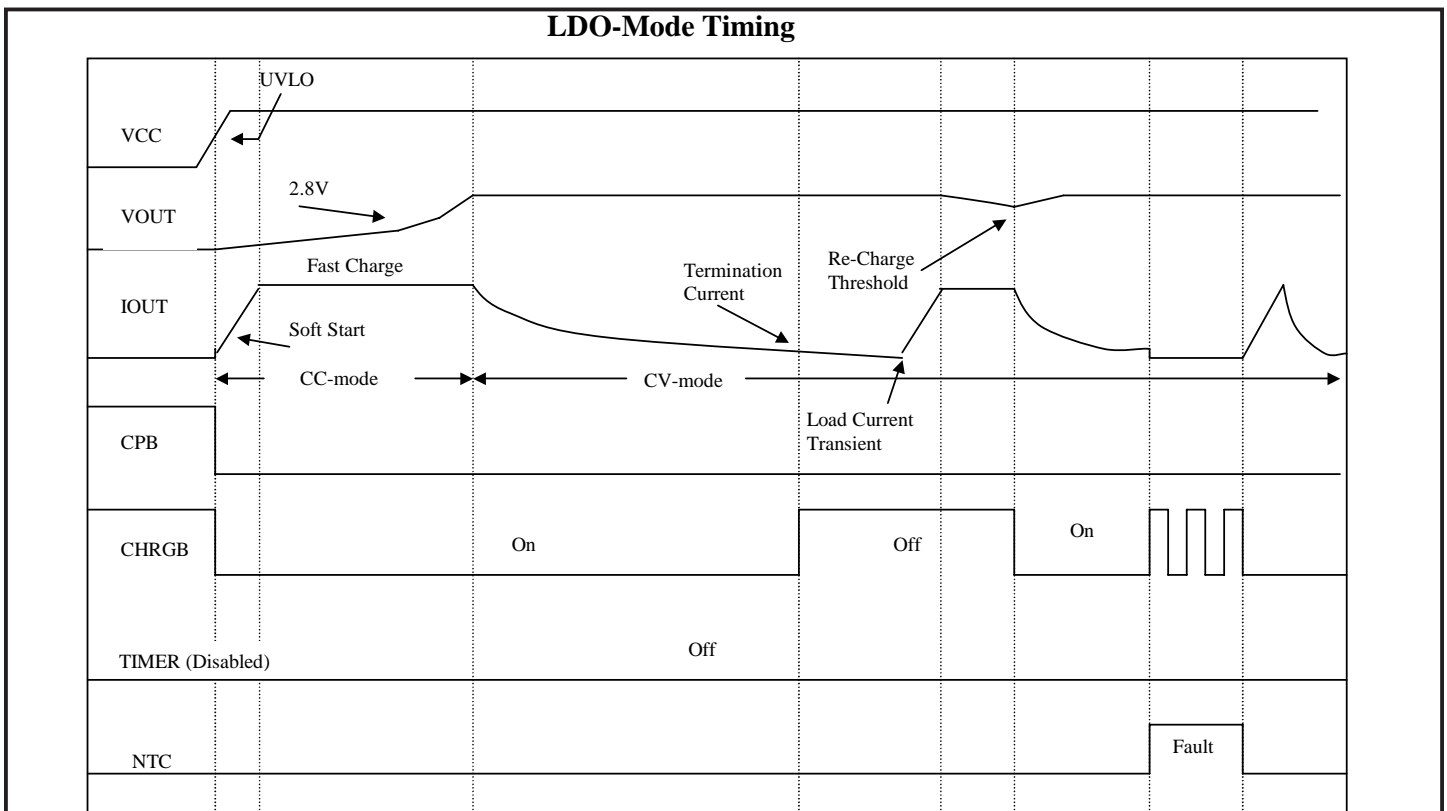

**POWER MANAGEMENT**

**Outline Drawing - MLP-16 (4 x 4 x 0.9mm)**

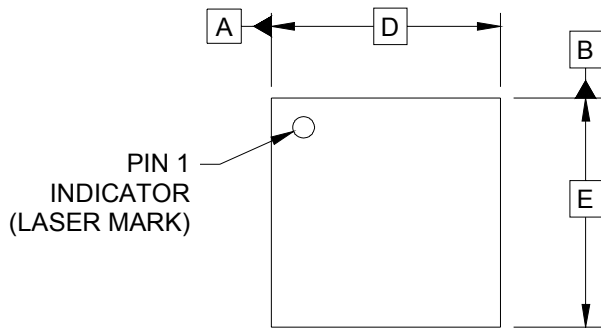

DIM	INCHES			MILLIMETERS		
	MIN	NOM	MAX	MIN	NOM	MAX
A	.031	-	.040	0.80	-	1.00
A1	.000	-	.002	0.00	-	0.05
A2	-	(.008)	-	-	(0.20)	-
b	.010	.012	.014	0.25	0.30	0.35
D	.153	.157	.161	3.90	4.00	4.10
D1	.079	.085	.089	2.00	2.15	2.25
E	.153	.157	.161	3.90	4.00	4.10
E1	.079	.085	.089	2.00	2.15	2.25
e	.026 BSC			0.65 BSC		
L	.018	.022	.026	0.45	0.55	0.65
N	16			16		
aaa	.003			0.08		
bbb	.004			0.10		

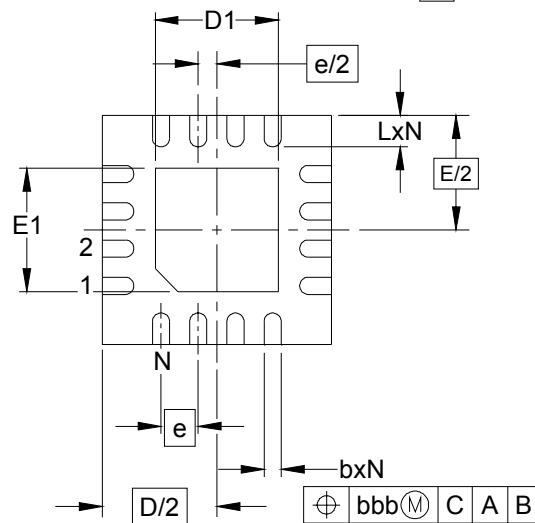
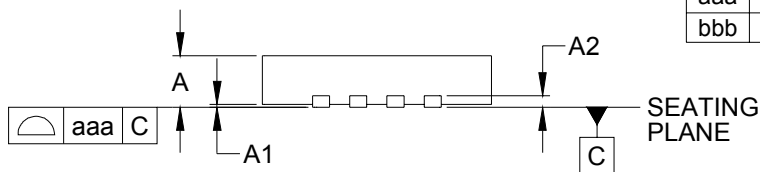

**NOTES:**

1. CONTROLLING DIMENSIONS ARE IN MILLIMETERS (ANGLES IN DEGREES).
2. COPLANARITY APPLIES TO THE EXPOSED PAD AS WELL AS THE TERMINALS.

**POWER MANAGEMENT**

**Land Pattern - MLP-16 (4 x 4 x 0.9mm)**

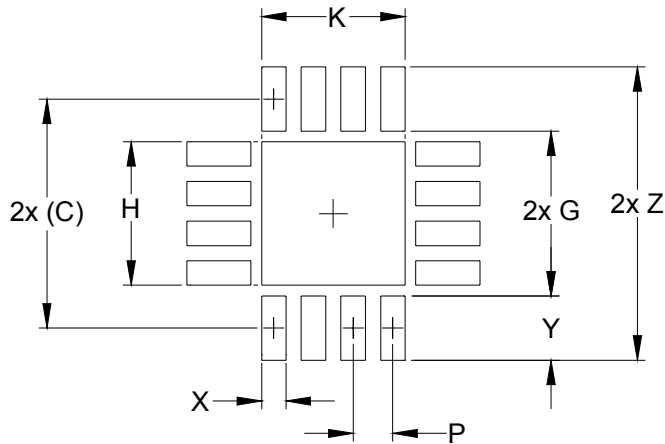

DIMENSIONS		
DIM	INCHES	MILLIMETERS
C	(.152)	(3.85)
G	.114	2.90
H	.091	2.30
K	.091	2.30
P	.026	0.65
X	.016	0.40
Y	.037	0.95
Z	.189	4.80

**NOTES:**

1. THIS LAND PATTERN IS FOR REFERENCE PURPOSES ONLY. CONSULT YOUR MANUFACTURING GROUP TO ENSURE YOUR COMPANY'S MANUFACTURING GUIDELINES ARE MET.

**Contact Information**

Semtech Corporation  
 Power Management Products Division  
 200 Flynn Road, Camarillo, CA 93012  
 Phone: (805)498-2111 FAX (805)498-3804