

# MITSUBISHI RF POWER TRANSISTOR 2SC1945

## NPN EPITAXIAL PLANAR TYPE

### DESCRIPTION

2SC1945 is a silicon NPN epitaxial planar type transistor designed for RF power amplifiers on HF band mobile radio applications.

### FEATURES

- High power gain:  $G_{pe} \geq 14.5\text{dB}$   
@  $V_{CC} = 12\text{V}$ ,  $P_O = 14\text{W}$ ,  $f = 27\text{MHz}$
- Emitter ballasted construction for high reliability and good performances.
- TO-220 package similarly is combinient for mounting.
- Ability of withstanding infinite load VSWR when operated at  $V_{CC} = 16\text{V}$ ,  $P_O = 18\text{W}$ ,  $f = 27\text{MHz}$ .

### APPLICATION

10 to 14 watts output power class AB amplifiers applications in HF band.

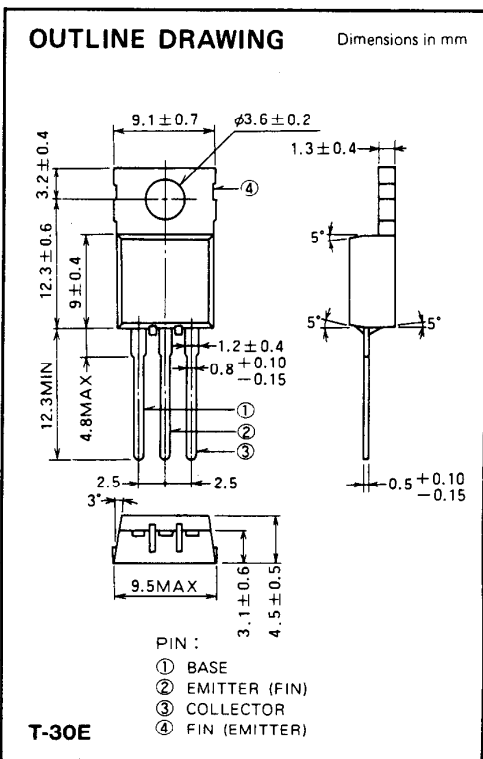

### ABSOLUTE MAXIMUM RATINGS ( $T_C = 25^\circ\text{C}$ unless otherwise specified)

Symbol	Parameter	Conditions	Ratings	Unit
$V_{CB0}$	Collector to base voltage		80	V
$V_{EB0}$	Emitter to base voltage		5	V
$V_{CE0}$	Collector to emitter voltage	$R_{BE} = \infty$	40	V
$I_C$	Collector current		6	A
$P_C$	Collector dissipation	$T_a = 25^\circ\text{C}$	1.5	W
		$T_C = 25^\circ\text{C}$	20	W
$T_j$	Junction temperature		150	$^\circ\text{C}$
$T_{stg}$	Storage temperature		-55 to 150	$^\circ\text{C}$
$R_{th-a}$	Thermal resistance	Junction to ambient	83.3	$^\circ\text{C/W}$
$R_{th-c}$		Junction to case	6.25	$^\circ\text{C/W}$

Note. Above parameters are guaranteed independently.

### ELECTRICAL CHARACTERISTICS ( $T_C = 25^\circ\text{C}$ unless otherwise specified)

Symbol	Parameter	Test conditions	Limits			Unit
			Min	Typ	Max	
$V_{(BR)EBO}$	Emitter to base breakdown voltage	$I_E = 5\text{mA}$ , $I_C = 0$	5			V
$V_{(BR)CBO}$	Collector to base breakdown voltage	$I_C = 1\text{mA}$ , $I_E = 0$	80			V
$V_{(BR)CEO}$	Collector to emitter breakdown voltage	$I_C = 10\text{mA}$ , $R_{BE} = \infty$	40			V
$I_{CBO}$	Collector cutoff current	$V_{CB} = 30\text{V}$ , $I_E = 0$			100	$\mu\text{A}$
$I_{EBO}$	Emitter cutoff current	$V_{EB} = 4\text{V}$ , $I_C = 0$			100	$\mu\text{A}$
$h_{FE}$	DC forward current gain *	$V_{CE} = 10\text{V}$ , $I_C = 0.1\text{A}$	10	50	180	—
$P_O$	Output power	$V_{CC} = 12\text{V}$ , $P_{in} = 0.5\text{W}$ , $f = 27\text{MHz}$	14	16		W
$\eta_C$	Collector efficiency		60	70		%

Note. \* Pulse test,  $P_W = 150\mu\text{s}$ , duty=5%  
 Above parameters, ratings, limits and conditions are subject to change.

NOV. '97



**TEST CIRCUIT**

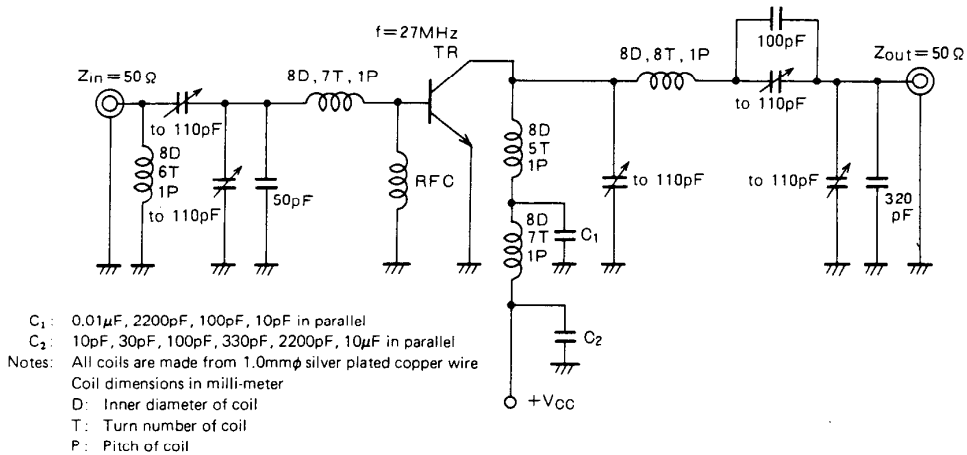

**TYPICAL PERFORMANCE DATA**

**COLLECTOR DISSIPATION VS. AMBIENT TEMPERATURE**

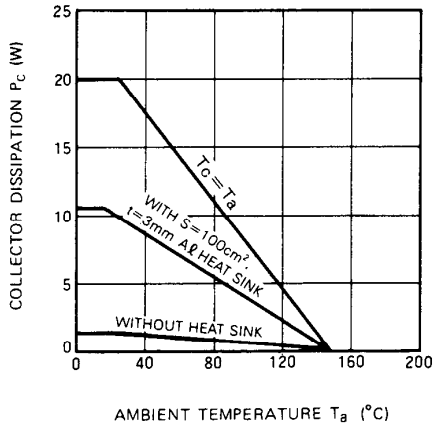

**COLLECTOR CURRENT VS. COLLECTOR TO EMITTER VOLTAGE**

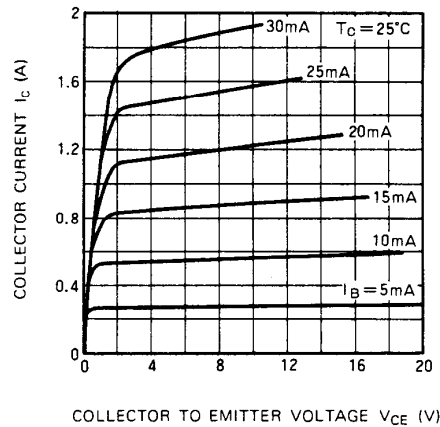

**DC CURRENT GAIN VS. COLLECTOR CURRENT**

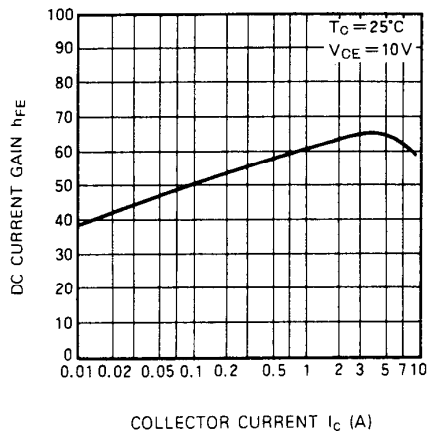

**COLLECTOR TO EMITTER BREAKDOWN VOLTAGE VS. BASE TO EMITTER RESISTANCE**

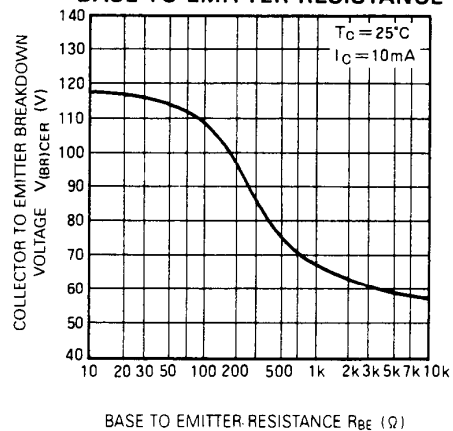

**NPN EPITAXIAL PLANAR TYPE**

**COLLECTOR OUTPUT CAPACITANCE VS. COLLECTOR TO BASE VOLTAGE**

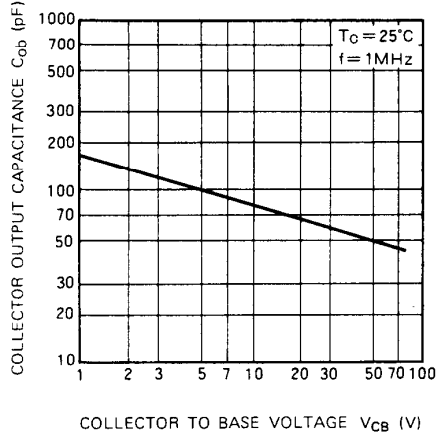

**OUTPUT POWER, COLLECTOR EFFICIENCY VS. INPUT POWER**

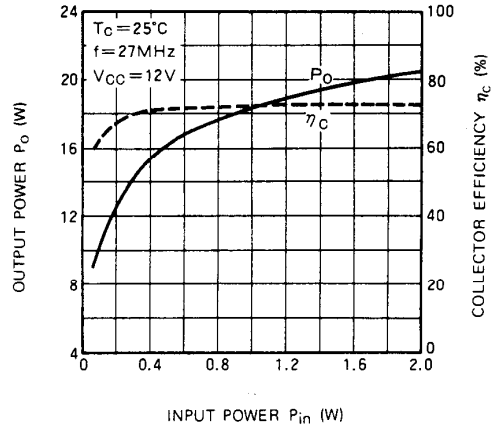

**OUTPUT POWER VS. COLLECTOR SUPPLY VOLTAGE**

