

# SKKE 380



SEMIPACK® 3 1)

## Rectifier Diode Modules

### SKKE 380

#### Features

- Heat transfer through aluminium nitride ceramic isolated metal baseplate
- Precise metal pressure contacts for high reliability
- UL recognized, file no. E 63 532

#### Typical Applications

- Line rectifiers for transistorized AC motor controllers
- Field supply for DC motors

- 1) Discontinued version, redesigned version already available
- 2) See the assembly instruction
- 3) The screws must be lubricated

|           |           |   |  |
|-----------|-----------|---|--|
| $V_{RSM}$ | $V_{RRM}$ | $I_{FRMS} = 600 \text{ A}$ (maximum value for continuous operation)       |  |
| V         | V         | $I_{FAV} = 380 \text{ A}$ (sin. 180; $T_c = 100 \text{ }^\circ\text{C}$ ) |  |
| 1300      | 1200      | SKKE 380/12   |  |
| 1700      | 1600      | SKKE 380/16   |  |

| Symbol        | Conditions  | Values                   | Units            |
|---------------|---|--------------------------|------------------|
| $I_{FAV}$     | sin. 180; $T_c = 100 \text{ }^\circ\text{C}$                  | 380                      | A                |
| $I_{FSM}$     | $T_{vj} = 25 \text{ }^\circ\text{C}$ ; 10 ms                  | 11000                    | A                |
|               | $T_{vj} = 150 \text{ }^\circ\text{C}$ ; 10 ms                 | 10000                    | A                |
| $i^2t$        | $T_{vj} = 25 \text{ }^\circ\text{C}$ ; 8,3 ... 10 ms          | 605000                   | A <sup>2</sup> s |
|               | $T_{vj} = 150 \text{ }^\circ\text{C}$ ; 8,3 ... 10 ms         | 500000                   | A <sup>2</sup> s |
| $V_F$         | $T_{vj} = 25 \text{ }^\circ\text{C}$ ; $I_F = 1000 \text{ A}$ | max. 1,25                | V                |
| $V_{(TO)}$    | $T_{vj} = 150 \text{ }^\circ\text{C}$                         | max. 0,8                 | V                |
| $r_T$         | $T_{vj} = 150 \text{ }^\circ\text{C}$                         | max. 0,35                | m $\Omega$       |
| $I_{RD}$      | $T_{vj} = 150 \text{ }^\circ\text{C}$ ; $V_{RD} = V_{RRM}$    | max. 15                  | mA               |
| $R_{th(j-c)}$ | cont.; per diode = per module                                 | 0,11                     | K/W              |
|               | sin. 180; per diode = per module                              | 0,116                    | K/W              |
| $R_{th(c-s)}$ | per diode = per module  | 0,04                     | K/W              |
| $T_{vj}$      |   | - 40 ... + 150           | $^\circ\text{C}$ |
| $T_{stg}$     |   | - 40 ... + 130           | $^\circ\text{C}$ |
| $V_{isol}$    | a. c. 50 Hz; r.m.s.; 1 s / 1 min.                             | 3600 / 3000              | V~               |
| $M_s$         | to heatsink   | $5 \pm 15 \text{ } \%^2$ | Nm               |
| $M_t$         | to terminals  | $9 \pm 15 \text{ } \%^3$ | Nm               |
| a             |   | $5 * 9,81$               | m/s <sup>2</sup> |
| m             | approx.   | 620                      | g                |
| Case          |   | A 77a                    |                  |



SKKE

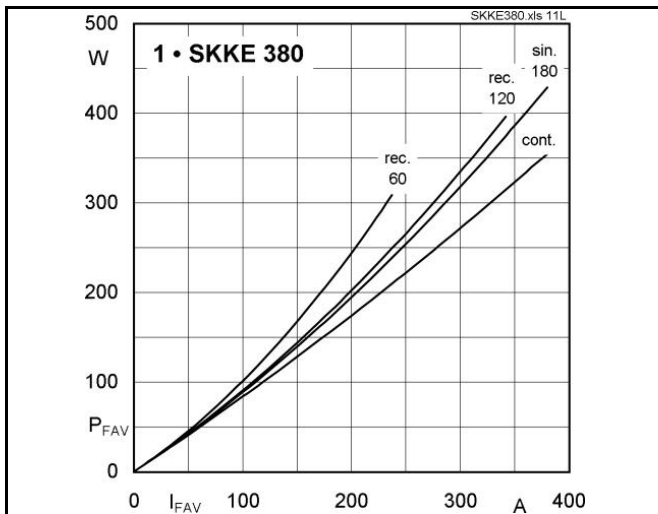

Fig. 11L Power dissipation per diode vs. forward current

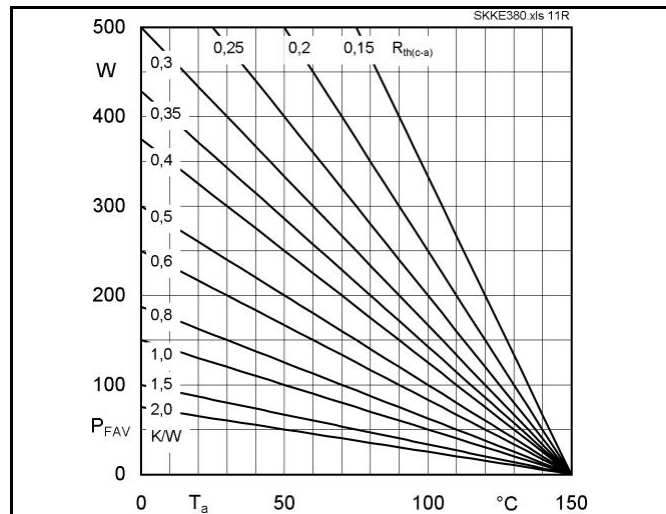

Fig. 11R Power dissipation per diode vs. ambient temperature

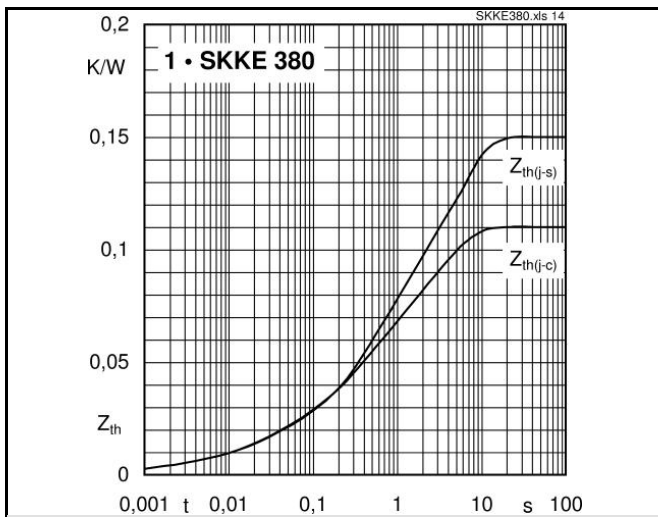

Fig. 14 Transient thermal impedance vs. time

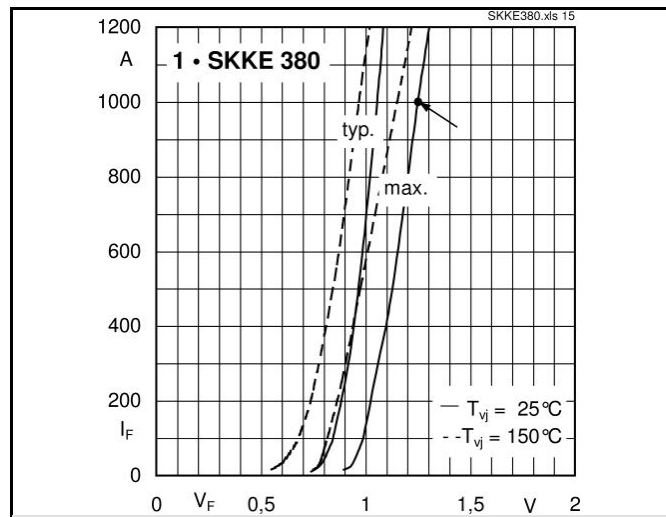

Fig. 15 Forward characteristics

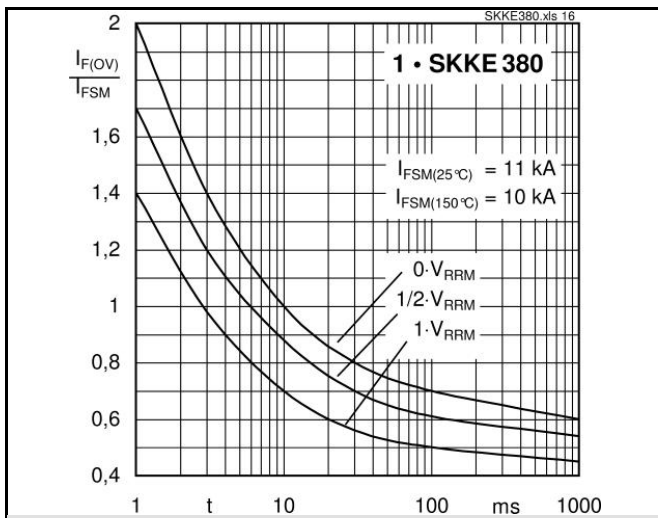
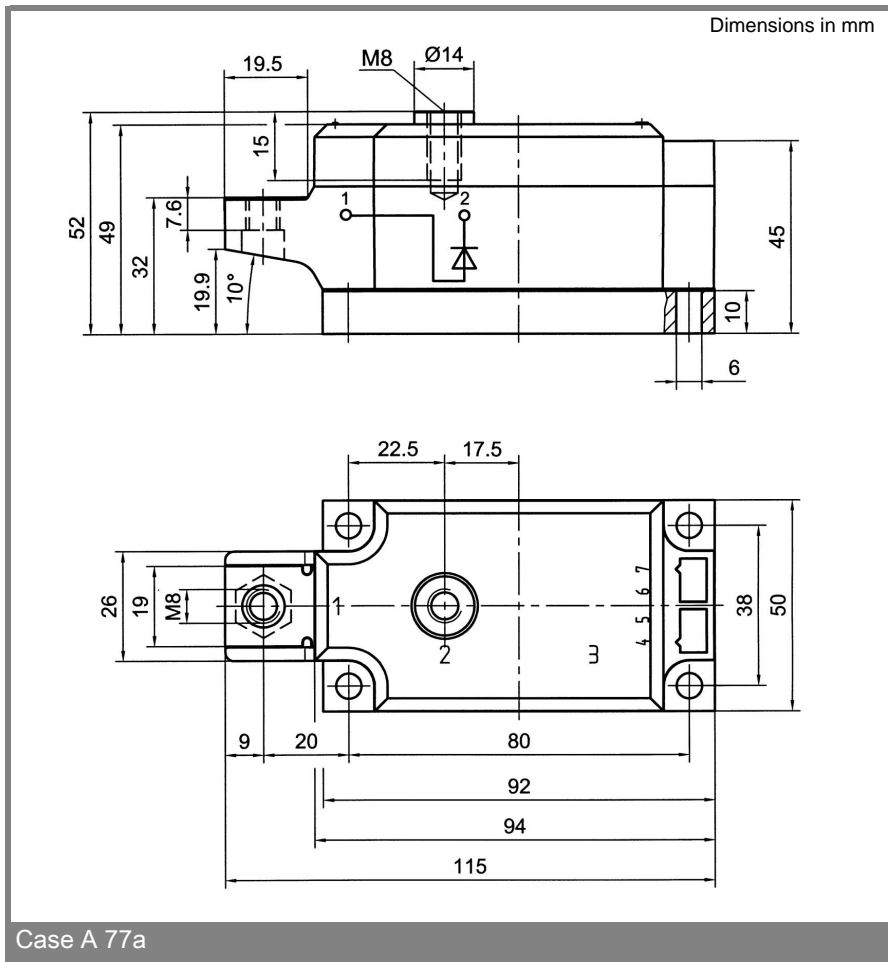

Fig. 16 Surge overload current vs. time

# SKKE 380



This technical information specifies semiconductor devices but promises no characteristics. No warranty or guarantee expressed or implied is made regarding delivery, performance or suitability.