

Classification	REFERENCE SPECIFICATION	Issue No.
Part Name	Part No.	5-1
LIGHT TOUCH SWITCH	EVQ P0E 07K	
<p>1. Notification Items</p> <p>1.1 Law and the regulation which are applied</p> <p>① This product has not been manufactured with ozone depleting chemical controlled under the Montreal Protocol.</p> <p>② This product complies with the RoHS Directive (Restriction of the use of certain Hazardous Substance) in electrical and electronic equipment (DIRECTIVE 2002/95/EC).</p> <p>③ All the materials used in this part are registered material under the Law Concerning the Examination and Regulation of Manufacture etc. or Chemical Substances.</p> <p>④ Permission must be obtained from the Japanese government if the product that is subject to the "Foreign Exchange and Foreign Trade Law" is to be exported or taken out of Japan.</p> <p>1.2 Application Limits</p> <p>This product was designed and manufactured for general electronics devices household appliances, office equipment, data and communication equipment.</p> <p>For the following applications in which high reliability and safety are required, or for the applications in which the failure or malfunction of the products may directly jeopardize life or cause threat of personal asset, please contact us beforehand.</p> <ul style="list-style-type: none"> · Aircraft and aerospace equipment, anti-disaster or anti-crime equipment, medical equipment, transport equipment(automotives, trains, boat etc), high public information processing devices or the other equipments or devices that are equivalent to the above mentioned. <p>1.3 Handling of reference specification.</p> <ul style="list-style-type: none"> · Since the contents of this reference specification are subjected to change without prior notifications, please request us a formal specification again for your investigations before using. <p>1.4 Manufacturing Sites</p> <p>① The country of manufacture : Japan Panasonic Electronic Devices Japan Co., Ltd.</p> <p>2. Summary</p> <p>2.1 This specifications applies to the following types of switch. Push-ON type S.P.S.T</p> <p>2.2 This specifications is a constituent document of contract for business concluded between your company and Panasonic Corporation.</p> <p>2.3 Items not particularly specified in this specifications shall be in conformance with JIS Standards.</p>		

Classification	REFERENCE SPECIFICATION	Issue No.
Part Name	Part No.	5-2
LIGHT TOUCH SWITCH	EVQ P0E 07K	

3. Dimension· Marking· Circuit diagram

Date code are indicated in the product.

General dimension tolerance : ± 0.2

() dimensions are reference dimensions.

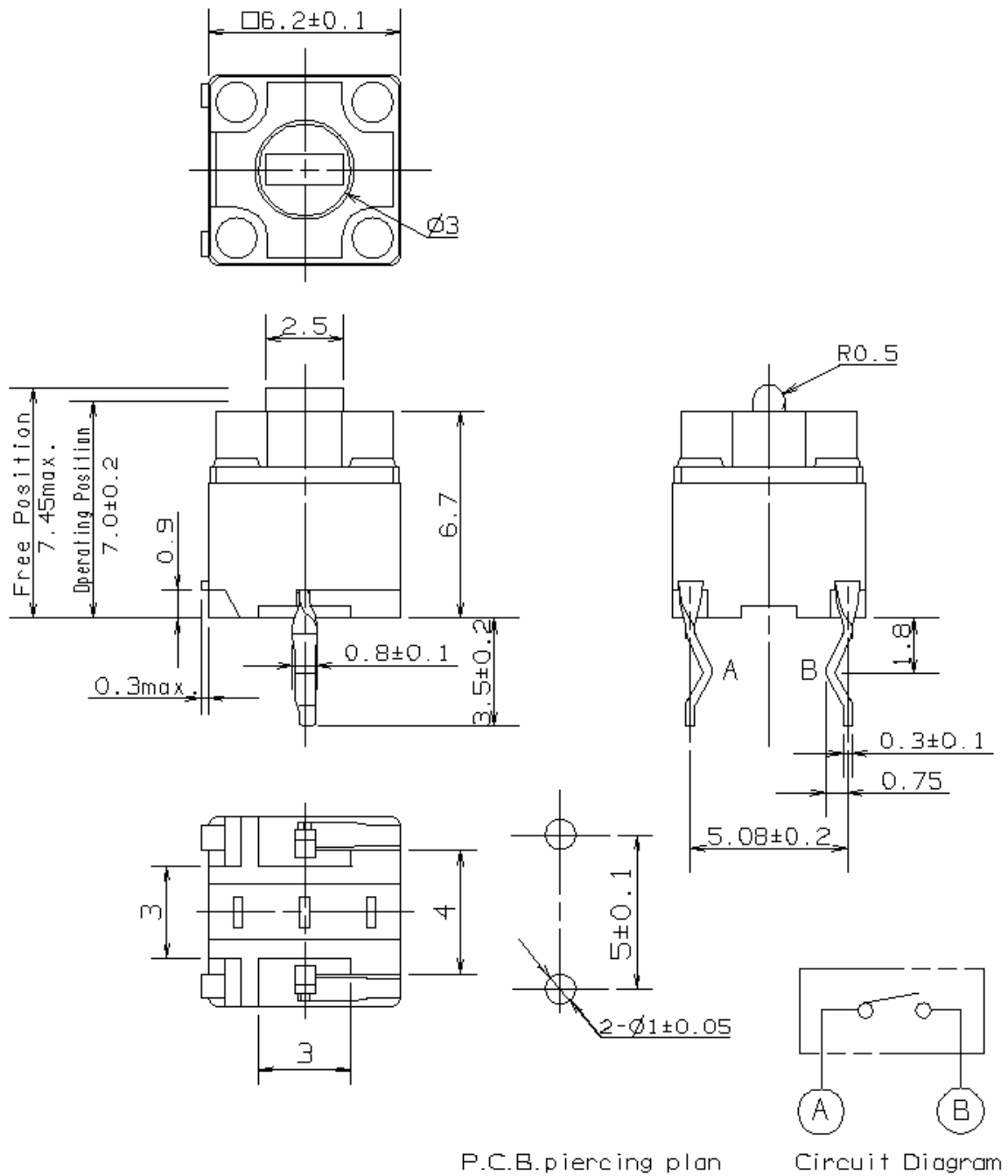

Classification	REFERENCE SPECIFICATION	Issue No.
Part Name	Part No.	5-4
LIGHT TOUCH SWITCH	EVQ P0E 07K	

9. Operation life

9.1 Allowable operating frequency 300 times/min max.

9.2 Allowable operating speed 1 ~ 5 mm/s

9.3

Item	The number of operations	Displacement of actuator
Electrical	5, 000, 000 min.	DC 5 V 1mA 2 ~ 3 operations/s
Mechanical	5, 000, 000 min.	TTP

After test

Contact resistance : 1000 (mΩ) max.

Operating force : within ±30% of initial force

10. Precaution

10.1 Soldering condition

Item	Condition
Preheat temperature	120°C max. (temperature of soldering surface of P.W.B.)
Preheat time	60s max.
Height of flux	1/2 max. of P.W.B. thickness
Temperature of soldering	260°C max.
Time of immersion	Within 5s
Soldering time	Within 2 times (Bringing down the heat after first soldering)
Printed wiring board	Single sided copper-clad laminates

11. Notes

11.1 Measuring condition : Unless otherwise specified, these standard range of atmospheric conditions for measuring and testing shall be as follows.

Standard temperature : 20°C

Standard humidity : 65%RH

When criteria have no doubts, test is done at temperature of 5°C to 35°C and humidity of 45%RH to 85%RH.

11.2 Recommendable tip for mechanical test :

The tip shown in the right figure is the recommended dimension.

Tip point shall be kept vertically at center-line of the switch.

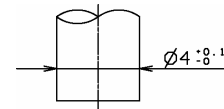

11.3 Precaution for handing

• Please be cautions not to apply over specified static load or shock to actuator of the switch.

• Re-soldering by soldering iron shall be allowed under 280°C max. 3 sec. max. 1 time.
Soldering iron for re-soldering have to be 20W max.

• Storage under high temperature, high humidity and corrosive gas should be avoided.
Especially, when long period preservation is needed, do not open the carton.

• After mount to P.W.B., a switch has be stored not to apply over specified load.

• Please be careful not to clean switches with water and solvent.

Classification	REFERENCE SPECIFICATION	Issue No.
Part Name	Part No.	5-5
LIGHT TOUCH SWITCH	EVQ P0E 07K	

<Prohibitions and precaution for handling>

【Prohibited items on fire and smoking】

- Absolutely avoid use of a product beyond its rated range because doing so may cause a fire. If misuse or abnormal use may result under conditions in which the product is used out of its rated range, take proper measures such as current interruption using a protective circuit.
- The grade of nonflammability for resin used in product is "94HB," which is based on UL94 Standards (flammability test for plastic materials). Prohibit use in a location where a spreading fire may be generated or prepare against a spreading fire.

【For use in equipment for which safety is requested】

- Although care is taken to ensure product quality, inferior characteristics, short circuits, and open circuits are some problems that might be generated. To design an equipment which places maximum emphasis on safety, review the effect of any single fault of a product in advance and perform virtually fail-safe design to ensure maximum safety by:
- Preparing a protective circuit or a protective device to improve system safety, and equipment.
- Preparing a redundant circuit to improve system safety so that the single fault of a product does not cause a dangerous situation.

【Attentions required for storage condition】

- When this product is to be stored in the following circumstances and conditions, it may affect on the performance deteriorations and solderability etc., avoid storing in the following conditions.
 - (1) A place where the temperature is -10°C max., +40°C min. and the humidity is 85% min.
 - (2) In the corrosive gas atmosphere.
 - (3) Long-term storage for 6 months min.
 - (4) A place where the product is exposed to direct sunlight.
- Store in packed condition so that the load stress is not applied.
- Please use this product as soon as possible, our recommendation is within 3 months and the limitation is 6 months.
- If any remainder left after packing is opened, store it with proper moistureproofing and gasproofing, etc.,
- The switch shall be packed by Nylon sheet in the box like original packaging style when it will be an inventory after using on the assembly machine at your production line.