

Classification	REFERENCE SPECIFICATION	Issue No. 20090997
Part Name LIGHT TOUCH SWITCH	Part No. EVQPR9A10	1/9
<p>1. Notification Items</p> <p>1.1 Law and the regulation which are applied</p> <p>①This product has not been manufactured with ozone depleting chemical controlled under the Montreal Protocol.</p> <p>②This product complies with the RoHS Directive (Restriction of the use of certain Hazardous Substance) in electrical and electronic equipment (DIRECTIVE 2002/95/EC).</p> <p>③All the materials used in this part are registered material under the Law Concerning the Examination and Regulation of Manufacture etc. or Chemical Substances.</p> <p>④Permission must be obtained from the Japanese government if the product that is subject to the "Foreign Exchange and Foreign Trade Law" is to be exported or taken out of Japan.</p> <p>1.2 Application Limits</p> <p>This product was designed and manufactured for general electronics devices household appliances, office equipment, data and communication equipment.</p> <p>For the following applications in which high reliability and safety are required, or for the applications in which the failure or malfunction of the products may directly jeopardize life or cause threat of personal asset, please contact us beforehand.</p> <ul style="list-style-type: none"> •Aircraft and aerospace equipment, anti-disaster or anti-crime equipment, medical equipment, transport equipment(automotives, trains, boat etc), high public information processing devices or the other equipments or devices that are equivalent to the above mentioned. <p>1.3 Handling of reference specification.</p> <ul style="list-style-type: none"> • Since the contents of this reference specification are subjected to change without prior notifications, please request us a formal specification again for your investigations before using. <p>1.4 Manufacturing Sites</p> <p>① The country of manufacture : Japan Panasonic Electronic Devices Japan Co., Ltd.</p> <p>2. Summary</p> <p>2.1 This specifications applies to the following types of switch. Push-ON type S.P.D.T</p> <p>2.2 This specifications is a constituent document of contract for business concluded between your company and Panasonic Corporation.</p> <p>2.3 Items not particularly specified in this specifications shall be in conformance with JIS Standards.</p>		

Panasonic Electronic Devices Co., Ltd.

Classification	REFERENCE SPECIFICATION	Issue No. 20090997
Part Name LIGHT TOUCH SWITCH	Part No. EVQPR9A10	2/9

3. Dimension • Marking • Circuit diagram

Date code are indicated in the product.

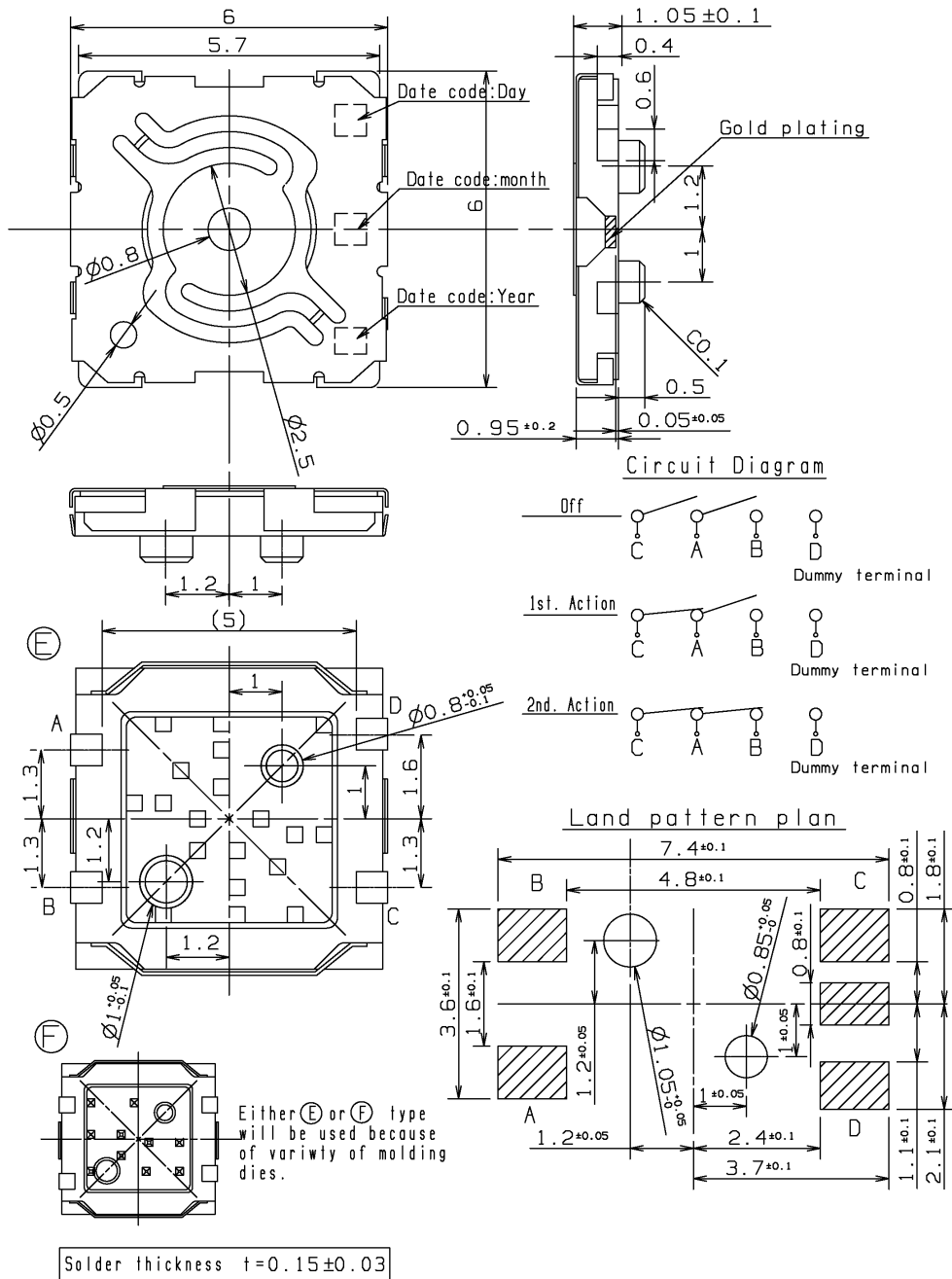

General dimension tolerance: ± 0.2
 () dimensions are reference dimensions.

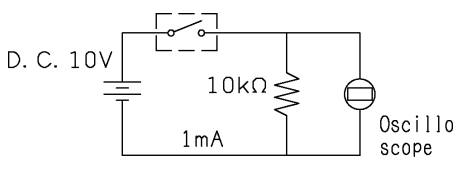

Classification		REFERENCE SPECIFICATION		Issue No.
Part Name LIGHT TOUCH SWITCH		Part No. EVQPR9A10		20090997
				3/9
4. General specification				
4.1 Switch rating		DC 15 V 20 mA(max.) DC 2V 10 μA(min.)		
4.2 Operation temperature range		-20 °C ~ +70 °C		
4.3 Preservative temperature range		Single condition : -40~+85 °C Taping condition : -20~+60 °C		
4.4 Standard conditions				
Unless otherwise specified, the test and measurements shall be carried out as follows.				
Ambient temperature : 5~35 °C				
Relative humidity : 45~85 %				
Air pressure : 86~106 kPa				
However, if doubt arises on the decision based on the measured values under the above-mentioned conditions, the following conditions shall be employed.				
Ambient temperature : 20 ± 2°C				
Relative humidity : 65 ± 5 %				
Air pressure : 86~106 kPa				
5. Performance				
5.1 Electrical characteristics				
No.	ITEM	TEST CONDITION	PERFORMANCE	
5.1.1	Contact resistance	Push force : {Operation force} × 2 Measurement tool : Contact resistance meter (Capable of 10 μA ~ 10 mA)	100 mΩ max.	
5.1.2	Insulation resistance	DC 100 V (Between terminals)	50 MΩ min.	
5.1.3	Withstand voltage	AC 100 V for 1 minute. (Between terminals)	No insulation destruction	
5.1.4	Bouncing	Operation speed : 3~4 times/s  Switch Bouncing Test Circuit	ON 3 ms max. OFF 20 ms max. Except when the 2nd switch is turning off.	

Classification	REFERENCE SPECIFICATION	Issue No. 20090997
Part Name LIGHT TOUCH SWITCH	Part No. EVQPR9A10	4/9

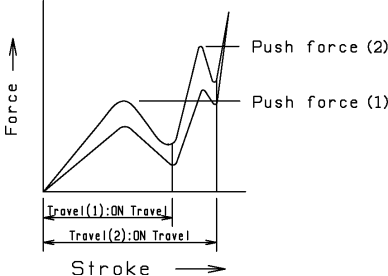
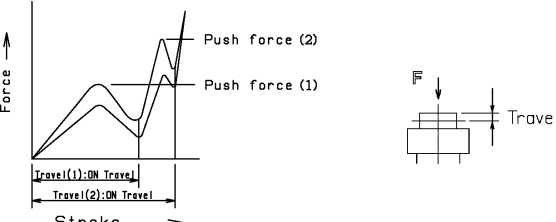
5.2 Mechanical characteristics

No.	ITEM	TEST CONDITION	PERFORMANCE
5.2.1	Operation force	Operation feeling shall be measured after 3 times pre-operations. Measurement speed:0.5mm/s 	Push force(1) $0.7 \begin{matrix} + 0.40 \\ - 0.40 \end{matrix} \text{ N}$
			Push force(2) $2.6 \begin{matrix} + 0.5 \\ - 0.7 \end{matrix} \text{ N}$
5.2.2	Travel to closure		Travel(1) $0.35 \begin{matrix} + 0.15 \\ - 0.15 \end{matrix} \text{ mm}$
			Travel(2) $0.35 \begin{matrix} + 0.15 \\ - 0.55 \end{matrix} \text{ mm}$
5.2.3	Push strength	20 N for 30 sec. 	No damage (Electrical and mechanical)
		50 N for 30 sec. 	Variation rate of Push force shall be within $\pm 30\%$ to the value before testing.
5.2.4	Vibration test	1) Amplitude : 1.5 mm 2) Sweep rate : 10-55-10Hz for 1 minute 3) Sweep method : Logarithmic frequency sweep rate 4) Vibration direction : X,Y,Z(3 directions) 5) Time : Each direction 2 hours (Total 6 hours)	No. 5.1 and 5.2.1 to 5.2.2 shall be satisfied.
5.2.5	Soldering heat test	Mount the switch on P.W.B by adhesive. 1) Reflow process 2 times. (Refer to section 6.1) 2) Standard conditions after test : 1 hours	Contact resistance 200 m Ω max. No. 5.1.2 to 5.1.4 and No. 5.2.1 to 5.2.2 shall be satisfied.
5.2.6	Solderbility	After spreading flux, the terminal is immersed in solder with following condition. Solder ber : M705/Sn-3.0Ag-0.5Cu (Senju Metal Indusry Co.,Ltd.) Flux : CF-110VH-2A (tamura kaken) Soldering temperture : $260 \pm 5^\circ\text{C}$ Soldering time : $2 \pm 0.5 \text{ sec.}$	95% or more of surface area(Excluding ruptured surface)where is immersed in solder shall be covered by new solder.

Classification	REFERENCE SPECIFICATION	Issue No. 20090997
Part Name LIGHT TOUCH SWITCH	Part No. EVQPR9A10	5/9

5.3 Climatic characteristics

No.	ITEM	TEST CONDITION	PERFORMANCE
5.3.1	Cold test	1) Temperature : -40 ± 2 °C 2) Duration of test : 500 h 3) Take off a drop water. 4) Standard conditions after test : 1 h	Contact resistance 200 mΩ max. No. 5.1.2 to 5.1.4 and No. 5.2.1 to 5.2.2 shall be satisfied.
5.3.2	Heat test	1) Temperature : 85 ± 2 °C 2) Duration of test : 500 h 3) Standard conditions after test : 1 h	Contact resistance 200 mΩ max. No. 5.1.2 to 5.1.4 and No. 5.2.1 to 5.2.2 shall be satisfied.
5.3.3	Heat shock test	1) Test cycles : 20 cycles 2) Standard conditions after test : 1 h <div style="text-align: center;"> <p style="margin-left: 20px;"> A: $+85\pm 2$ °C B: -40 ± 2 °C C: 1 hour D: 5 minutes max. E: 1 hour F: 5 minutes max. </p> </div>	Contact resistance 200 mΩ max. No. 5.1.2 to 5.1.4 and No. 5.2.1 to 5.2.2 shall be satisfied.
5.3.4	Humidity test	1) Temperature : 60 ± 2 °C 2) Relative humidity : 90~95 % 3) Duration of test : 500 h 4) Take off a drop water. 5) Standard conditions after test : 1 h	Contact resistance 200 mΩ max. No. 5.1.2 to 5.1.4 and No. 5.2.1 to 5.2.2 shall be satisfied.
5.3.5	Endurance (Switching action)	1) DC 15 V 20 mA Resistance load 2) Operation speed : 2~3 times/s 3) Push force : Maximum value of operation force 4) Operation number : 30,000 times	Contact resistance 10 Ω max. Bouncing : 20 ms max. Variation rate of operation force shall be within ± 30 % to the value before testing No. 5.1.2 and 5.2.2 shall be satisfied.
5.3.6	Withstand H ₂ S	1) Density : 3 ± 1 ppm 2) Temperature : 40 ± 2 °C 3) Relative humidity : 80~85 % 4) Duration of test : 24 h 5) Standard conditions after test : 1 h	Contact resistance 200 mΩ max. No. 5.1.2 to 5.1.4 and No. 5.2.1 to 5.2.2 shall be satisfied.

Classification	REFERENCE SPECIFICATION	Issue No. 20090997
Part Name LIGHT TOUCH SWITCH	Part No. EVQPR9A10	6/9

6. Prohibitions and precaution for handling

In order to prevent accidents or performance deteriorations in use of the product, observe the following restrictions and pay attentions to the following items.

<Restrictions>

- 1) Wave soldering (by solder bath dwelling) is prohibited because this switch does not have a capability. Therefore, be sure to perform soldering by reflow method.
- 2) Do not put this switch into the washing process after soldering because this switch does not have a capability of washing even water.

6.1 Reflow soldering condition

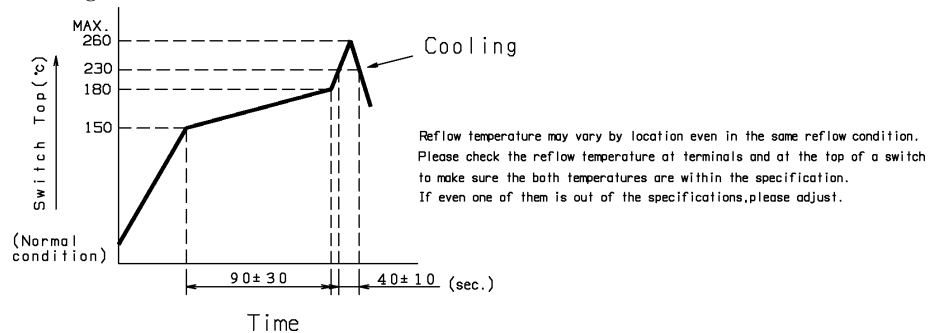

- 1) Two times max. with directing the switch mounting side of P.W.B up.
- 2) Re-soldering by soldering iron shall be allowed under 350°C max. 3 sec. max. 1 time only and the tip of iron must not touch to terminals.
Soldering iron for re-soldering have to be 60W max.
- 3) Do not put any object such as a weight etc. on the operating knob.

6.2 Design instructions

- 1) Please refer to the land pattern plan Panasonic recommends on the 2nd page.
- 2) Design the operating section on the setting side as shown in the Fig-1.
Inclination shall be within 4 degree. (Refer to the Fig-2)

(In case of using elastic materials such as rubber for the button or actuator on the set, this product would have possibility not to work properly due to excessive slanted actuator.)
The switch and the decentering shall be 0.3mm max..

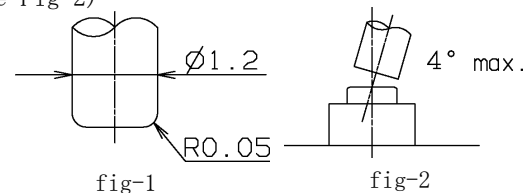

6.3 Notes

- 1) Do not apply excessive load on this product.
Pay special attention to the terminal section.
It may be a cause of terminal deformation, bad contact, or malfunction.
- 2) To prevent a bad contact caused by foreign particles (dust particles of P.W.B., dust particles of flux) into the inside of the switch, pay attention to handle the P.W.B. after mounting. And do not pile up the P.W.B..
- 3) Do not push the rubber sheet with sharp edged pole. It will cause a failure of sealing.
- 4) Please put your attention not to locate big amount of solder paste around the switch, like adding extra land patterns besides the switch, because flux ingress to inside of the switch may occur.
- 5) This switch is for making a momentary signal. It is prohibited using the switch at a function that expects long time signal (long time contact close).

Classification	REFERENCE SPECIFICATION	Issue No. 20090997
Part Name LIGHT TOUCH SWITCH	Part No. EVQPR9A10	7/9
<p>6.4 Attentions Required for Circuit Condition</p> <p>6.4.1 Rating</p> <p>(1) In order to assure the reliability, use this product within the rating range specified in the Specifications.</p> <p>(2) Rated power is a maximum value of the power which can be continuous load at rated ambient temperature.</p> <p>(3) If the product is used over the rated power, the correct characteristics may not be gained or the product may be burnt.</p> <p>(4) The circuit shall be designed to avoid the inrush current to the switch, also avoid the surge voltage to be applied.</p> <p>(5) When the switches is used under a few μA (dry circuit), contact resistance may affect circuit property, so please use the switch under specified switch rating.</p> <p>6.4.2 Attentions Required for Bouncing and Chattering</p> <p>In order to prevent the malfunction by chattering caused by bouncing at switch-operation of ON/OFF and external vibration etc., please pay attention to the design shown below.</p> <p>1) Read several times.</p> <p>2) Set the delay time.</p> <p>3) Set the CR integration circuit.</p> <p>6.5 Attentions Required for Mounting and Operating Condition</p> <p>6.5.1 Operating temperature</p> <p>In order to assure the reliability, use this product within the operating temperature range specified in the Specifications.</p> <p>6.5.2 Operating relative humidity</p> <p>Do not use this product under relative humidity of 85% min. for a long time. (Except applications considered appropriate countermeasure)</p> <p>Avoid using this product in a place where it is directly exposed to the wheather, or where humidity is high caused by steam and dew condensation, etc.</p> <p>6.5.3 The product is not a sealed type.</p> <p>Avoid the use under following circumstance and conditions as it may affect a bad influence to characteristics.</p> <p>(1) In the corrosive gas atmospere, such as Cl₂, H₂S, NH₃, NO_x, SO₂ gas.</p> <p>(2) Waterdrop remained, dew condensation, Waterdrop adhered.</p> <p>(3) In the solution of water, sale water, oil, chemicals, and organic solvents.</p> <p>(4) A place where it is exposed to direct sunlight.</p> <p>(5) A place with large amounts of dust or dirt particles.</p> <p>6.5.4 The structure of this product is not waterproof, chemicals resistance and solvent resistance. Do not wet with water, chemicals and/or solvents.</p> <p>6.5.5 Do not apply the vibration, the shock (drop, etc.) or the pressure to this product more than specified.</p> <p>6.5.6 Push strength</p> <p>In order to avoid damages of the switch, do not apply the load to the operating section more than specified. (If the load is applied more than specified, it may affect on the characteristics of the push stroke, etc.)</p> <p>6.5.7 Avoid the use of the switch under pushed ON condition is continued for a long time.</p> <p>6.6 Repair·Service</p> <p>6.6.1 When additional solder to the mounting soldering section of this product is to be performed or soldering section is to be removed, pay attention not to apply excessive stress and the temperature.</p> <p>6.6.2 Pay attention not to melt the insulation material or the resin section, and avoid deformation.</p>		

Classification	REFERENCE SPECIFICATION	Issue No. 20090997
Part Name LIGHT TOUCH SWITCH	Part No. EVQPR9A10	8/9

7. Packing specification
Carrier tape

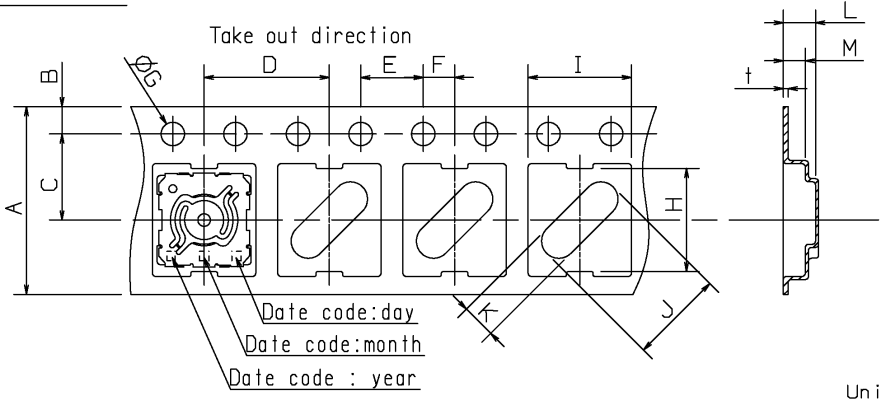

Unit:mm

A	B	C	D	E	F	G	H	I	J	K	L	M	t
±0.3	±0.15	±0.15	±0.15	±0.15	±0.15	±0.1	±0.3	±0.3	±0.3	±0.2	±0.1	±0.05	±0.05
12	1.75	5.5	8	4	2	1.5	6.3	6.3	6	2	1.7	1	0.3

Taping condition : Lack of products in the middle of taping should be one MAX, but total quantity specified in the specifications should be secured.

Peeling off strength of top tape : It should be within 0.2N to 1.0N at 165 degree in peeling off angle.

Joint of carrier tape : One joint per one reel may exist.

Reel(5000pcs./reel)

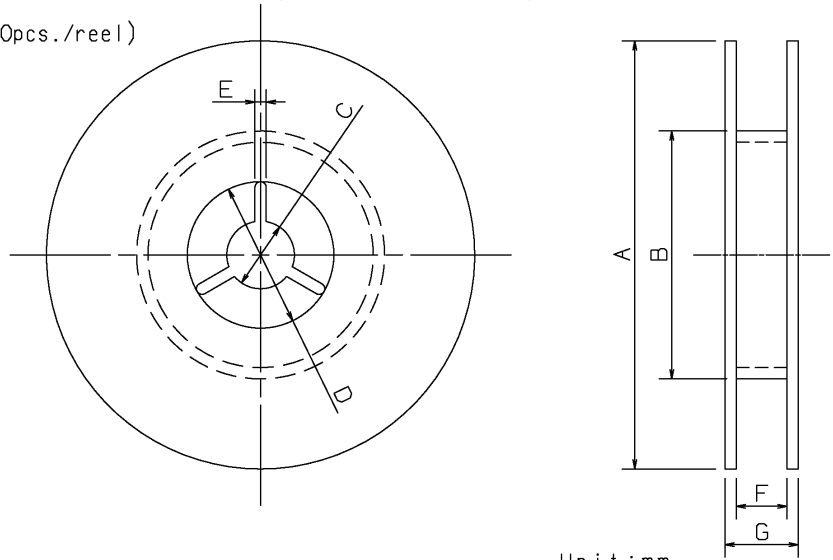

Unit : mm

A	B	C	D	E	F	G
±2	±1	±0.5	±1	±0.5	±1	±1
φ380	φ80	φ13	φ21	2	13.5	17.5

Classification	REFERENCE SPECIFICATION	Issue No. 20090997
Part Name LIGHT TOUCH SWITCH	Part No. EVQPR9A10	9/9
<p><Prohibitions and precaution for handling></p> <p>【Prohibited items on fire and smoking】</p> <ul style="list-style-type: none"> • Absolutely avoid use of a product beyond its rated range because doing so may cause a fire. If misuse or abnormal use may result under conditions in which the product is used out of its rated range, take proper measures such as current interruption using a protective circuit. • The grade of nonflammability for resin used in product is "94HB," which is based on UL94 Standards (flammability test for plastic materials). Prohibit use in a location where a spreading fire may be generated or prepare against a spreading fire. <p>【For use in equipment for which safety is requested】</p> <ul style="list-style-type: none"> • Although care is taken to ensure product quality, inferior characteristics, short circuits, and open circuits are some problems that might be generated, To design an equipment which places maximum emphasis on safety, review the effect of any single fault of a product in advance and perform virtually fail-safe design to ensure maximum safety by: <ul style="list-style-type: none"> • Preparing a protective circuit or a protective device to improve system safety, and equipment. • Preparing a redundant circuit to improve system safety so that the single fault of a product does not cause a dangerous situation. <p>【Attentions required for storage condition】</p> <ul style="list-style-type: none"> • When this product is to be stored in the following circumstances and conditions, it may affect on the performance deteriorations and solderability etc., avoid storing in the following conditions. <ol style="list-style-type: none"> (1) A place where the temperature is -10°C max., +40°C min. and the humidity is 85% min. (2) In the corrosive gas atmosphere. (3) Long-term storage for 6 months min. (4) A place where the product is exposed to direct sunlight. • Store in packed condition so that the load stress is not applied. • Please use this product as soon as possible, our recommendation is within 3 months and the limitation is 6 months. • If any remainder left after packing is opened, store it with proper moistureproofing and gasproofing, etc., 		