

Classification	REFERENCE SPECIFICATION	Issue No. 20090917
Part Name LIGHT TOUCH SWITCH	Part No. EVQP6PB35	1/10
<p>1. Notification Items</p> <p>1.1 Law and the regulation which are applied</p> <p>①This product has not been manufactured with ozone depleting chemical controlled under the Montreal Protocol.</p> <p>②This product complies with the RoHS Directive (Restriction of the use of certain Hazardous Substance) in electrical and electronic equipment (DIRECTIVE 2002/95/EC).</p> <p>③All the materials used in this part are registered material under the Law Concerning the Examination and Regulation of Manufacture etc. or Chemical Substances.</p> <p>④Permission must be obtained from the Japanese government if the product that is subject to the "Foreign Exchange and Foreign Trade Law" is to be exported or taken out of Japan.</p> <p>1.2 Application Limits</p> <p>This product was designed and manufactured for general electronics devices household appliances, office equipment, data and communication equipment.</p> <p>For the following applications in which high reliability and safety are required, or for the applications in which the failure or malfunction of the products may directly jeopardize life or cause threat of personal asset, please contact us beforehand.</p> <ul style="list-style-type: none"> •Aircraft and aerospace equipment, anti-disaster or anti-crime equipment, medical equipment, transport equipment(automotives, trains, boat etc), high public information processing devices or the other equipments or devices that are equivalent to the above mentioned. <p>1.3 Handling of reference specification.</p> <ul style="list-style-type: none"> • Since the contents of this reference specification are subjected to change without prior notifications, please request us a formal specification again for your investigations before using. <p>1.4 Manufacturing Sites</p> <p>① The country of manufacture : Japan Panasonic Electronic Devices Japan Co., Ltd.</p> <p>2. Summary</p> <p>2.1 This specifications applies to the following types of switch. Push-ON type S.P.S.T</p> <p>2.2 This specifications is a constituent document of contract for business concluded between your company and Panasonic Corporation.</p> <p>2.3 Items not particularly specified in this specifications shall be in conformance with JIS Standards.</p>		

Panasonic Electronic Devices Co., Ltd.

Classification	REFERENCE SPECIFICATION	Issue No. 20090917
Part Name LIGHT TOUCH SWITCH	Part No. EVQP6PB35	2/10

3. Dimension · Marking · Circuit diagram

Date code are indicated in the product.

General dimension tolerance : ± 0.1

() dimensions are reference dimensions.

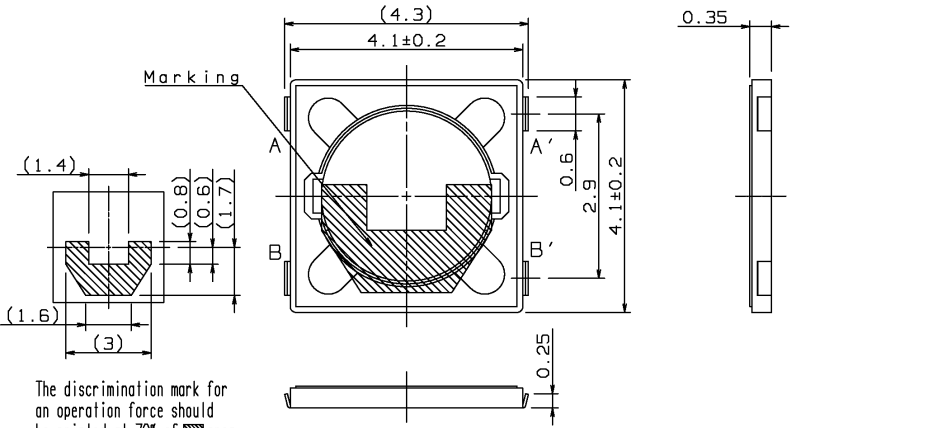

The discrimination mark for an operation force should be printed at 70% of area.

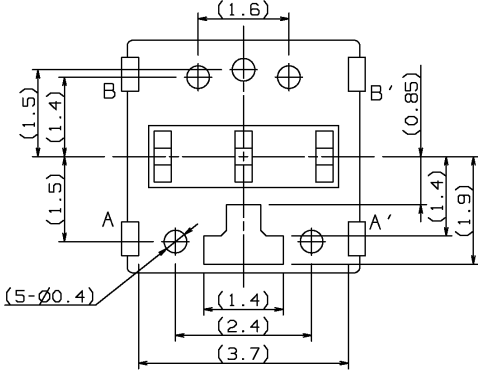

Piece weight :about 0.012g

Solder thickness t=0.15±0.03

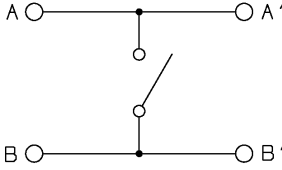
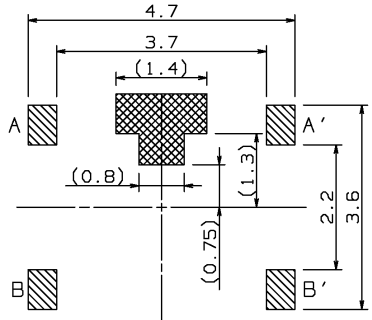

Circuit Diagram

Land pattern plan
Part of A-A' terminal is exposed at area.
Any land pattern or vias shall not be provided at area.

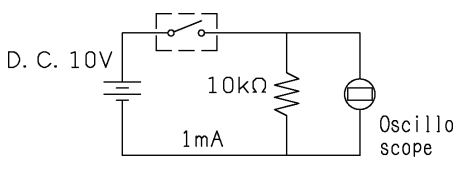
Classification		REFERENCE SPECIFICATION		Issue No.
				20090917
Part Name	LIGHT TOUCH SWITCH	Part No.	EVQP6PB35	
				3/10
4. General specification				
4.1	Switch rating	DC 15 V 20 mA(max.) DC 2V 10 μ A(min.)		
4.2	Operation temperature range	-20 $^{\circ}$ C ~ +70 $^{\circ}$ C		
4.3	Preservative temperature range	Single condition : -40~+85 $^{\circ}$ C Taping condition : -20~+60 $^{\circ}$ C		
4.4	Standard conditions	<p>Unless otherwise specified, the test and measurements shall be carried out as follows.</p> <p>Ambient temperature : 5~35 $^{\circ}$C Relative humidity : 45~85 % Air pressure : 86~106 kPa</p> <p>However, if doubt arises on the decision based on the measured values under the above-mentioned conditions, the following conditions shall be employed.</p> <p>Ambient temperature : 20 \pm 2 $^{\circ}$C Relative humidity : 65 \pm 5 % Air pressure : 86~106 kPa</p>		
5. Performance				
5.1 Electrical characteristics				
No.	ITEM	TEST CONDITION	PERFORMANCE	
5.1.1	Contact resistance	Push force : {Operation force} \times 2 Measurement tool : Contact resistance meter (Capable of 10 μ A ~ 10 mA)	500 m Ω max.	
5.1.2	Insulation resistance	DC 100 V (Between terminals)	50 M Ω min.	
5.1.3	Withstand voltage	AC 100 V for 1 minute. (Between terminals)	No insulation destruction	
5.1.4	Bouncing	<p>Operation speed : 3~4 times/s</p>  <p style="text-align: center;"><u>Switch Bouncing Test Circuit</u></p>	<p>ON 3 ms max.</p> <p>OFF 10 ms max.</p>	

Classification		REFERENCE SPECIFICATION		Issue No.
Part Name LIGHT TOUCH SWITCH		Part No. EVQP6PB35		20090917
				4/10
5.2 Mechanical characteristics				
No.	ITEM	TEST CONDITION		PERFORMANCE
5.2.1	Operation force			Push force $2.4 + 0.60$ $- 0.60$ N Return force 0.3 N min.
5.2.2	Travel to closure			$0.20 + 0.10$ $- 0.10$ mm
5.2.3	Push strength	50 N for 15 sec.		No damage (Electrical and mechanical)
5.2.4	Vibration test	1) Amplitude : 1.5 mm 2) Sweep rate : 10-55-10Hz for 1 minute 3) Sweep method : Logarithmic frequency sweep rate 4) Vibration direction : X,Y,Z(3 directions) 5) Time : Each direction 2 hours (Total 6 hours)		No. 5.1 and 5.2.1 to 5.2.2 shall be satisfied.
5.2.5	Soldering heat test	Mount the switch on P.W.B by adhesive. 1) Reflow process 3 times. (Refer to section 6.1) 2) Standard conditions after test : 1 hours		Contact resistance 500 mΩ max. No. 5.1.2 to 5.1.4 and No. 5.2.1 to 5.2.2 shall be satisfied.
5.2.6	Solderbility	After spreading flux, the terminal is immersed in solder with following condition. Solder ber : M705/Sn-3.0Ag-0.5Cu (Senju Metal Indusry Co.,Ltd.) Flux : CF-110VH-2A (tamura kaken) Soldering temperture : $260 \pm 5^{\circ}\text{C}$ Soldering time : 2 ± 0.5 sec.		95% or more of surface area(Excluding ruptured surface)where is immersed in solder shall be covered by new solder.

Classification	REFERENCE SPECIFICATION	Issue No. 20090917
Part Name LIGHT TOUCH SWITCH	Part No. EVQP6PB35	5/10

5.3 Climatic characteristics

No.	ITEM	TEST CONDITION	PERFORMANCE
5.3.1	Cold test	1) Temperature : -40 ± 2 °C 2) Duration of test : 500 h 3) Take off a drop water. 4) Standard conditions after test : 1 h	Contact resistance 1000 mΩ max. No. 5.1.2 to 5.1.4 and No. 5.2.1 to 5.2.2 shall be satisfied.
5.3.2	Heat test	1) Temperature : 85 ± 2 °C 2) Duration of test : 500 h 3) Standard conditions after test : 1 h	Contact resistance 1000 mΩ max. No. 5.1.2 to 5.1.4 and No. 5.2.1 to 5.2.2 shall be satisfied.
5.3.3	Heat shock test	1) Test cycles : 20 cycles 2) Standard conditions after test : 1 h <div style="text-align: center;"> <p style="margin-left: 20px;"> A: $+85\pm 2$ °C B: -40 ± 2 °C C: 1 hour D: 5 minutes max. E: 1 hour F: 5 minutes max. </p> </div>	Contact resistance 1000 mΩ max. No. 5.1.2 to 5.1.4 and No. 5.2.1 to 5.2.2 shall be satisfied.
5.3.4	Humidity test	1) Temperature : 60 ± 2 °C 2) Relative humidity : 90~95 % 3) Duration of test : 500 h 4) Take off a drop water. 5) Standard conditions after test : 1 h	Contact resistance 1000 mΩ max. No. 5.1.2 to 5.1.4 and No. 5.2.1 to 5.2.2 shall be satisfied.
5.3.5	Endurance (Switching action)	1) DC 15 V 20 mA Resistance load 2) Operation speed : 2~3 times/s 3) Push force : Maximum value of operation force 4) Operation number : 500,000 times	Contact resistance 20 Ω max. Bouncing : 10 ms max. Variation rate of operation force shall be within ± 30 % to the value before testing No. 5.1.2 and 5.2.2 shall be satisfied.
5.3.6	Withstand H ₂ S	1) Density : 3 ± 1 ppm 2) Temperature : 40 ± 2 °C 3) Relative humidity : 80~85 % 4) Duration of test : 24 h 5) Standard conditions after test : 1 h	Contact resistance 1000 mΩ max. No. 5.1.2 to 5.1.4 and No. 5.2.1 to 5.2.2 shall be satisfied.

Classification	REFERENCE SPECIFICATION	Issue No. 20090917
Part Name LIGHT TOUCH SWITCH	Part No. EVQP6PB35	6/10

6. Prohibitions and precaution for handling

In order to prevent accidents or performance deteriorations in use of the product, observe the following restrictions and pay attentions to the following items.

【Restrictions】

- 1) Wave soldering (by solder bath dwelling) is prohibited because this switch does not have a capability. Therefore, be sure to perform soldering by reflow method.
- 2) Do not put this switch into the washing process after soldering because this switch does not have a capability of washing even water.

6.1 Reflow soldering condition

- 1) Therefore, be sure to perform soldering by following reflow temperature profile.

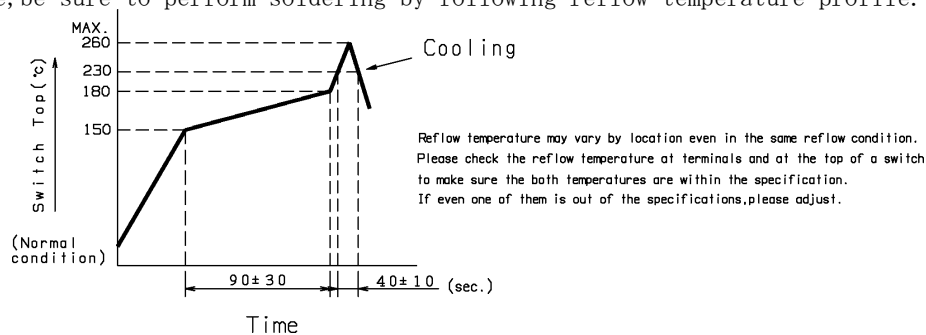

- 2) Three times max. It is possible to conduct reflow soldering with switch side down after at least one time soldering with switch up, but the drop of switch from the PCB and/or flux ingress might happen depend on your manufacturing/soldering condition. So please check if these phenomena do not happen with your manufacturing/soldering process.
- 3) Please do not load extra heat and pressure during re-work process by iron soldering. In the process of re-work the power of iron solder should be less than 60 watts and soldering condition should be as follows,
Temperature : 350 °C max., Period : 3 seconds max. Time : 1 time only.
- 4) Do not put any object such as a weight etc. on the operating knob during soldering.
- 5) In case that this switch is mounted on FPC board like film, we expect the board shall be tough by putting additional board for reinforcement on the reverse side.
We are concerned that the switch may be damaged due to an extra stress with multiple undulations from FPC board after soldering.

6.2 Mounting condition

- 1) As this product is thin and small type, when the mechanical chuck is to be used at automatic mounting, it is subject to be deformed, Please mount after sufficiently adjustment.

6.3 Handling after soldering

- 1) Do not load extra pressure on the switch after soldering.
Example, under the condition like stack of the P.C. bd on the switch.
- 2) Do not make a extra bending condition of P.C. bd like below figure.

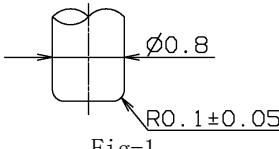
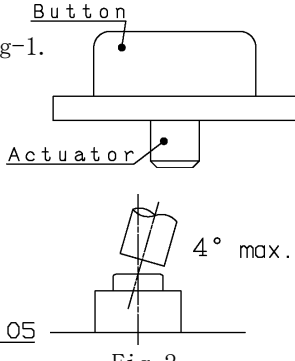

- 3) In case of using a masking tape on a P.C. db, do not put it on the switch.

Classification	REFERENCE SPECIFICATION	Issue No. 20090917
Part Name LIGHT TOUCH SWITCH	Part No. EVQP6PB35	7/10
<p>6.4 Attentions Required for Unit Design at customer side.</p> <p>1) Design the operating section on the setting side as shown in the Fig-1. Inclination shall be within 4 degree. (Refer to the Fig-2) The switch and the decentering shall be 0.3mm max. For use of this switch, press the center portion as much as possible, however, the life when the switch is pressed deviated from the center is shown below.</p> <div style="display: flex; justify-content: space-around; align-items: center;">   </div>		
<p>6.5 Attentions Required for Other Items</p> <ol style="list-style-type: none"> 1) Do not apply excessive load on this product. The stopper that shall be put on a button due to protection of this product against excessive load. Pay special attention to the terminal section. It may be a cause of terminal deformation, bad contact, or malfunction. 2) To prevent a bad contact caused by foreign particles (dust particles of P.W.B., dust, Particles of flux) into the inside of the switch, pay attention to handle the P.W.B. after mounting. And do not pile up the P.W.B.. 3) For storage of this product, avoid the place at high temperature and humidity, and where corrosive gas may be generated. Especially for a long-term storage, do not take out from the package and avoid storing with a loosed condition. 4) Avoid pressing the film portion of the product with sharp-edged object. 5) Please put your attention not to locate big amount of solder paste around the switch, like adding extra land patterns besides the switch, because flux ingress to inside of the switch may occur. 6) This switch is for making a momentary signal. It is prohibited using the switch at a function that expects long time signal (long time contact close). 7) There is a possibility the flux from solder paste infiltrates into the body if plenty of solder paste was applied by switch on the P.W.B. So we recommend to use our proposed land design in order to prevent above problem. Also please avoid putting additional land by the switch on the P.W.B. <p>6.6 Attentions Required for Circuit Condition</p> <p>6.6.1 Rating</p> <ol style="list-style-type: none"> (1) In order to assure the reliability, use this product within the rating range specified in the Specifications. (2) Rated power is a maximum value of the power which can be continuous load at rated ambient temperature. (3) If the product is used over the rated power, the correct characteristics may not be gained or the product may be burnt. (4) The circuit shall be designed to avoid the inrush current to the switch, also avoid the surge voltage to be applied. (5) When the switches is used under a few μA (dry circuit), contact resistance may affect circuit property, so please use the switch under specified switch rating. 		

Classification	REFERENCE SPECIFICATION	Issue No. 20090917
Part Name LIGHT TOUCH SWITCH	Part No. EVQP6PB35	8/10
<p>6.6.2 Attentions Required for Bouncing and Chattering</p> <p>In order to prevent the malfunction by chattering caused by bouncing at switch-operation of ON/OFF and external vibration etc., please pay attention to the design shown below.</p> <ol style="list-style-type: none"> 1) Read several times. 2) Set the delay time. 3) Set the CR integration circuit. <p>6.7 Attentions Required for Mounting and Operating Condition</p> <p>6.7.1 Operating temperature</p> <p>In order to assure the reliability, use this product within the operating temperature range specified in the Specifications.</p> <p>6.7.2 Operating relative humidity</p> <p>Do not use this product under relative humidity of 85% min. for a long time. (Except applications considered appropriate countermeasure)</p> <p>Avoid using this product in a place where it is directly exposed to the weather, or where humidity is high caused by steam and dew condensation, etc.</p> <p>6.7.3 The product is not a sealed type.</p> <p>Avoid the use under following circumstance and conditions as it may affect a bad influence to characteristics.</p> <ol style="list-style-type: none"> (1) In the corrosive gas atmosphere, such as Cl₂, H₂S, NH₃, NO_x, SO₂ gas. (2) Waterdrop remained, dew condensation, Waterdrop adhered. (3) In the solution of water, sea water, oil, chemicals, and organic solvents. (4) A place where it is exposed to direct sunlight. (5) A place with large amounts of dust or dirt particles. <p>6.7.4 The structure of this product is not waterproof, chemicals resistance and solvent resistance. Do not wet with water, chemicals and/or solvents.</p> <p>6.7.5 Do not apply the vibration, the shock (drop, etc.) or the pressure to this product more than specified.</p> <p>6.7.6 Push strength</p> <p>In order to avoid damages of the switch, do not apply the load to the operating section more than specified. (If the load is applied more than specified, it may affect on the characteristics of the push stroke, etc.)</p> <p>6.7.7 Avoid the use of the switch under pushed ON condition is continued for a long time.</p> <p>6.8 Repair・Service</p> <p>6.8.1 When additional solder to the mounting soldering section of this product is to be performed or soldering section is to be removed, pay attention not to apply excessive stress and the temperature.</p> <p>6.8.2 Pay attention not to melt the insulation material or the resin section, and avoid deformation.</p>		

Classification	REFERENCE SPECIFICATION	Issue No. 20090917
Part Name LIGHT TOUCH SWITCH	Part No. EVQP6PB35	9/10

7. Packing specification

Carrier tape

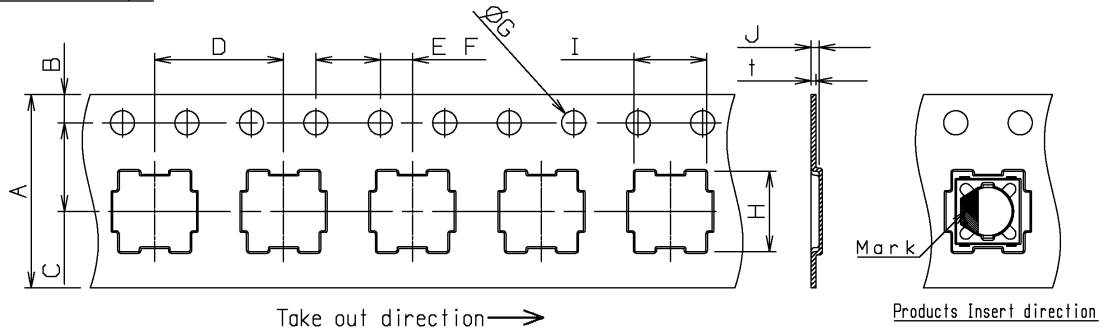

Unit:mm

A	B	C	D	E	F	G	H	I	J	t
$\begin{matrix} +0.3 \\ -0.1 \end{matrix}$	± 0.1	± 0.1	± 0.1	± 0.1	± 0.1	$\begin{matrix} +0.1 \\ -0 \end{matrix}$	± 0.2	± 0.2	$\begin{matrix} +0.2 \\ -0.1 \end{matrix}$	± 0.05
12	1.75	5.5	8	4	2	1.5	5	4.5	0.5	0.3

Taping condition : Lack of products in the middle of taping should be one MAX, but total quantity specified in the specifications should be secured.

Peeling off strength of top tape : It should be within 0.2N to 1.0N at 165 degree in peeling off angle.

Joint of carrier tape : One joint per one reel may exist.

Reel(10000pcs./reel)

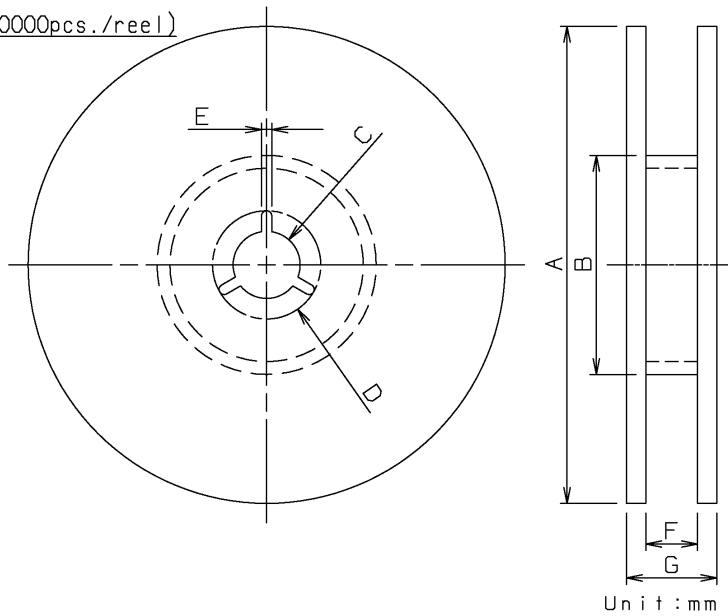

Unit:mm

A	B	C	D	E	F	G
± 2	± 1	± 0.5	± 1	± 0.5	± 1	± 1
$\phi 380$	$\phi 80$	$\phi 13$	$\phi 21$	2	13.5	17.5

Classification	REFERENCE SPECIFICATION	Issue No. 20090917
Part Name LIGHT TOUCH SWITCH	Part No. EVQP6PB35	10/10
<p><Prohibitions and precaution for handling></p> <p>【Prohibited items on fire and smoking】</p> <ul style="list-style-type: none"> • Absolutely avoid use of a product beyond its rated range because doing so may cause a fire. If misuse or abnormal use may result under conditions in which the product is used out of its rated range, take proper measures such as current interruption using a protective circuit. • The grade of nonflammability for resin used in product is "94HB," which is based on UL94 Standards (flammability test for plastic materials). Prohibit use in a location where a spreading fire may be generated or prepare against a spreading fire. <p>【For use in equipment for which safety is requested】</p> <ul style="list-style-type: none"> • Although care is taken to ensure product quality, inferior characteristics, short circuits, and open circuits are some problems that might be generated, To design an equipment which places maximum emphasis on safety, review the effect of any single fault of a product in advance and perform virtually fail-safe design to ensure maximum safety by: <ul style="list-style-type: none"> • Preparing a protective circuit or a protective device to improve system safety, and equipment. • Preparing a redundant circuit to improve system safety so that the single fault of a product does not cause a dangerous situation. <p>【Attentions required for storage condition】</p> <ul style="list-style-type: none"> • When this product is to be stored in the following circumstances and conditions, it may affect on the performance deteriorations and solderability etc., avoid storing in the following conditions. <ol style="list-style-type: none"> (1) A place where the temperature is -10°C max., +40°C min. and the humidity is 85% min. (2) In the corrosive gas atmosphere. (3) Long-term storage for 6 months min. (4) A place where the product is exposed to direct sunlight. • Store in packed condition so that the load stress is not applied. • Please use this product as soon as possible, our recommendation is within 3 months and the limitation is 6 months. • If any remainder left after packing is opened, store it with proper moistureproofing and gasproofing, etc., 		