

1.5A HIGH-SPEED 30V MOSFET DRIVERS

FEATURES

- High Peak Output Current 1.5A
- Wide Operating Range 5V to 30V
- High Capacitive Load
Drive Capability 1000 pF in 25nsec
- Short Delay Time <78nsec Typ
- Low Supply Current
 - With Logic “1” Input 2.5mA
 - With Logic “0” Input 300µA
- Low Output Impedance 7Ω
- Latch-Up Protected Will Withstand >300mA Reverse Current
- ESD Protected 4 kV

GENERAL DESCRIPTION

The TC4431/4432 are 30V CMOS buffer/drivers suitable for use in high-side driver applications. They will not latch up under any conditions within their power and voltage ratings. They can accept, without damage or logic upset, up to 300mA of reverse current (of either polarity) being forced back into their outputs. All terminals are fully protected against up to 4kV of electrostatic discharge.

Under-voltage lockout circuitry forces the output to a "low" state when the input supply voltage drops below 7V. Maximum startup V_{DD} bias voltage threshold is 10V. For operation at lower voltages, the LOCK DIS, Pin 3 can be grounded to disable the lockout and start-up circuit. The under-voltage lockout and start-up circuit gives brown out protection when driving MOSFETS.

4

ORDERING INFORMATION

Part No.	Package	Temperature Range
TC4431COA	8-Pin SOIC	0°C to +70°C
TC4431CPA	8-Pin Plastic DIP	0°C to +70°C
TC4431EJA	8-Pin CerDIP	-40°C to +85°C
TC4431EOA	8-Pin SOIC	-40°C to +85°C
TC4431EPA	8-Pin Plastic DIP	-40°C to +85°C

Part No.	Package	Temperature Range
TC4432COA	8-Pin SOIC	0°C to +70°C
TC4432CPA	8-Pin Plastic DIP	0°C to +70°C
TC4432EJA	8-Pin CerDIP	-40°C to +85°C
TC4432EOA	8-Pin SOIC	-40°C to +85°C
TC4432EPA	8-Pin Plastic DIP	-40°C to +85°C

FUNCTIONAL BLOCK DIAGRAM

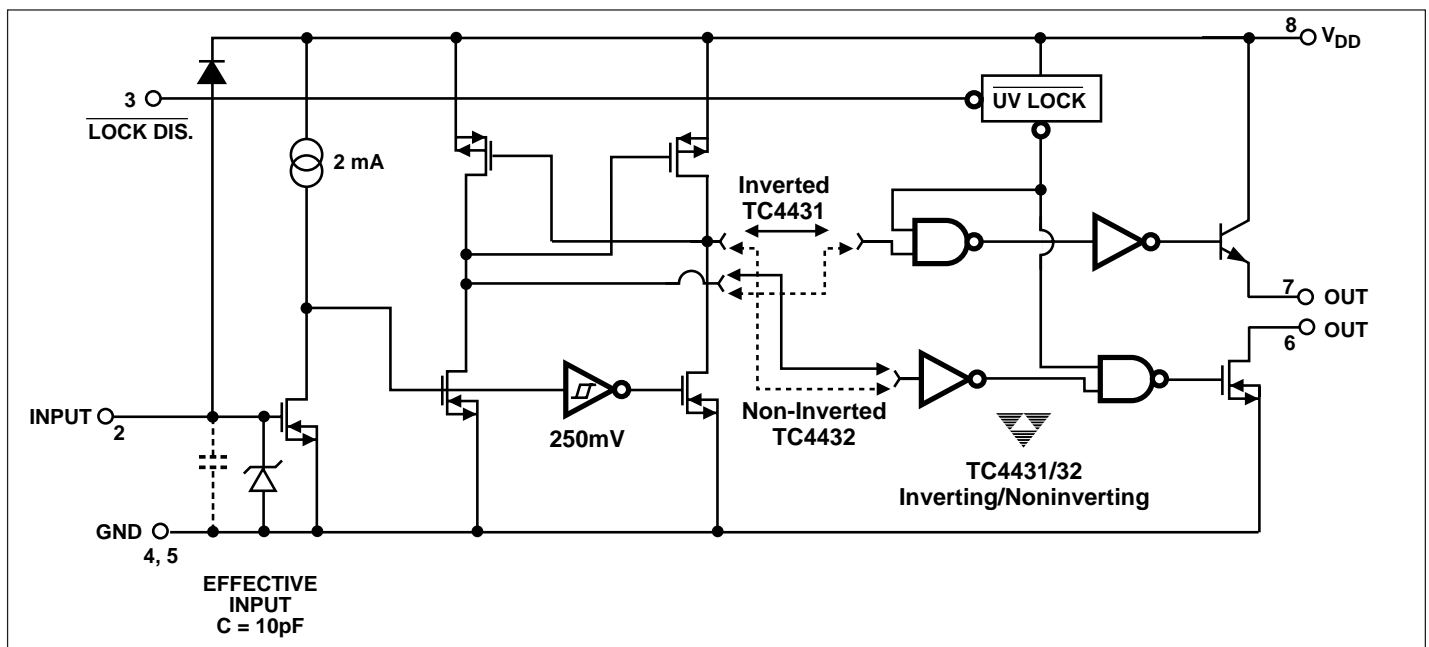

1.5A HIGH-SPEED 30V MOSFET DRIVERS

TC4431 TC4431

ABSOLUTE MAXIMUM RATINGS*

Supply Voltage	36V
Input Voltage (Note 1)	$V_{DD} + 0.3V$ to GND
Maximum Chip Temperature	+150°C
Storage Temperature Range	- 65°C to +150°C
Lead Temperature (Soldering, 10 sec)	+300°C
Package Thermal Resistance	
CerDIP $R_{\theta J-A}$	150°C/W
CerDIP $R_{\theta J-C}$	50°C/W
PDIP $R_{\theta J-A}$	125°C/W
PDIP $R_{\theta J-C}$	42°C/W
SOIC $R_{\theta J-A}$	250°C/W
SOIC $R_{\theta J-C}$	75°C/W

Operating Temperature Range

C Version	0°C to +70°C
E Version	- 40°C to +85°C
Package Power Dissipation ($T_A \leq 70^\circ\text{C}$)	
Plastic	730mW
CerDIP	800mW
SOIC	470mW

*Static-sensitive device. Unused devices must be stored in conductive material. Protect devices from static discharge and static fields. Stresses above those listed under "Absolute Maximum Ratings" may cause permanent damage to the device. These are stress ratings only and functional operation of the device at these or any other conditions above those indicated in the operation sections of the specifications is not implied. Exposure to absolute maximum rating conditions for extended periods may affect device reliability.

ELECTRICAL CHARACTERISTICS: $T_A = +25^\circ\text{C}$ with $5.0 \leq V_{DD} \leq 30V$, unless otherwise specified.

Symbol	Parameter	Test Conditions	Min	Typ	Max	Unit
Input						
V_{IH}	Logic 1 High Input Voltage		2.4	—	—	V
V_{IL}	Logic 0 Low Input Voltage		—	—	0.8	V
I_{IN}	Input Current (Note 1)	$0V \leq V_{IN} \leq V_{DD}$ (16V MAX)	-1	—	1	μA
Output						
V_{OH}	High Output Voltage	$I_{OUT} = 100\text{mA}$	$V_{DD} - 1.0$	$V_{DD} - 0.8$	—	V
V_{OL}	Low Output Voltage		—	—	0.025	V
R_O	Output Resistance (V_{OL})	$V_{DD} = 30V, I_O = 10\text{mA}$	—	7	10	Ω
I_{PK}	Peak Output Current	Source: $V_{DD} = 30V$ Sink: $V_{DD} = 30V$	—	3.0	—	A
I_{REV}	Latch-Up Protection Withstand Reverse Current	Duty Cycle $\leq 2\%$ $t \leq 300 \mu\text{sec}$	0.3	—	—	A
Switching Time (Note 2)						
t_R	Rise Time	Figure 1	—	25	40	nsec
t_F	Fall Time	Figure 1	—	33	50	nsec
t_{D1}	Delay Time	Figure 1	—	62	80	nsec
t_{D2}	Delay Time	Figure 1	—	78	90	nsec
Power Supply						
I_S	Power Supply Current	$V_{IN} = 3V$ $V_{IN} = 0V$	—	2.5	4	mA
V_S	Start-up Threshold		—	8.4	10	V
V_{DO}	Drop-out Threshold	(Note 3)	7	7.7	—	V

1.5A HIGH-SPEED 30V MOSFET DRIVERS

TC4431
TC4432

ELECTRICAL CHARACTERISTICS (Cont.): Specifications measured over operating temperature range with $5.0V \leq V_{DD} \leq 30V$, unless otherwise specified.

Symbol	Parameter	Test Conditions	Min	Typ	Max	Unit
Input						
V_{IH}	Logic 1 High Input Voltage		2.4	—	—	V
V_{IL}	Logic 0 Low Input Voltage		—	—	0.8	V
I_{IN}	Input Current (Note 1)	$0V \leq V_{IN} \leq V_{DD}$ (16V MAX)	-1	—	1	μA
Output						
V_{OH}	High Output Voltage	$I_{OUT} = 100mA$	$V_{DD} - 1.2$	—	—	V
V_{OL}	Low Output Voltage		—	—	0.025	V
R_O	Output Resistance	$V_{DD} = 30V, I_O = 10mA$	—	—	12	Ω
Switching Time (Note 2)						
t_R	Rise Time	Figure 1	—	—	60	nsec
t_F	Fall Time	Figure 1	—	—	70	nsec
t_{D1}	Delay Time	Figure 1	—	—	100	nsec
t_{D2}	Delay Time	Figure 1	—	—	110	nsec
Power Supply						
I_S	Power Supply Current	$V_{IN} = 3V$ $V_{IN} = 0V$	—	—	6 0.7	mA
V_S	Start-up Threshold		—	8.4	10	V
V_{DO}	Drop-out Threshold	(Note 3)	7	7.7	—	V

- NOTES:** 1. For inputs >16V, add a 1k Ω resistor in series with the input. See graph on page 4 for input current.
2. Switching times are guaranteed by design.
3. For operation below 7V, the LOCK DIS., Pin 3 can be grounded to disable the lockout and start-up circuit.

PIN CONFIGURATIONS

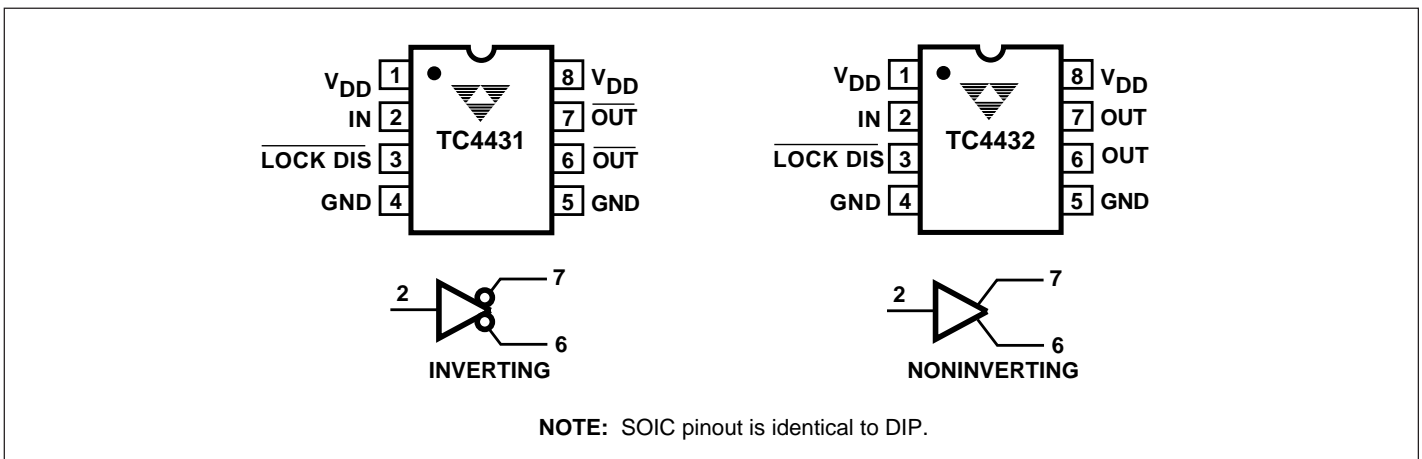

4

1.5A HIGH-SPEED 30V MOSFET DRIVERS

TC4431
TC4431

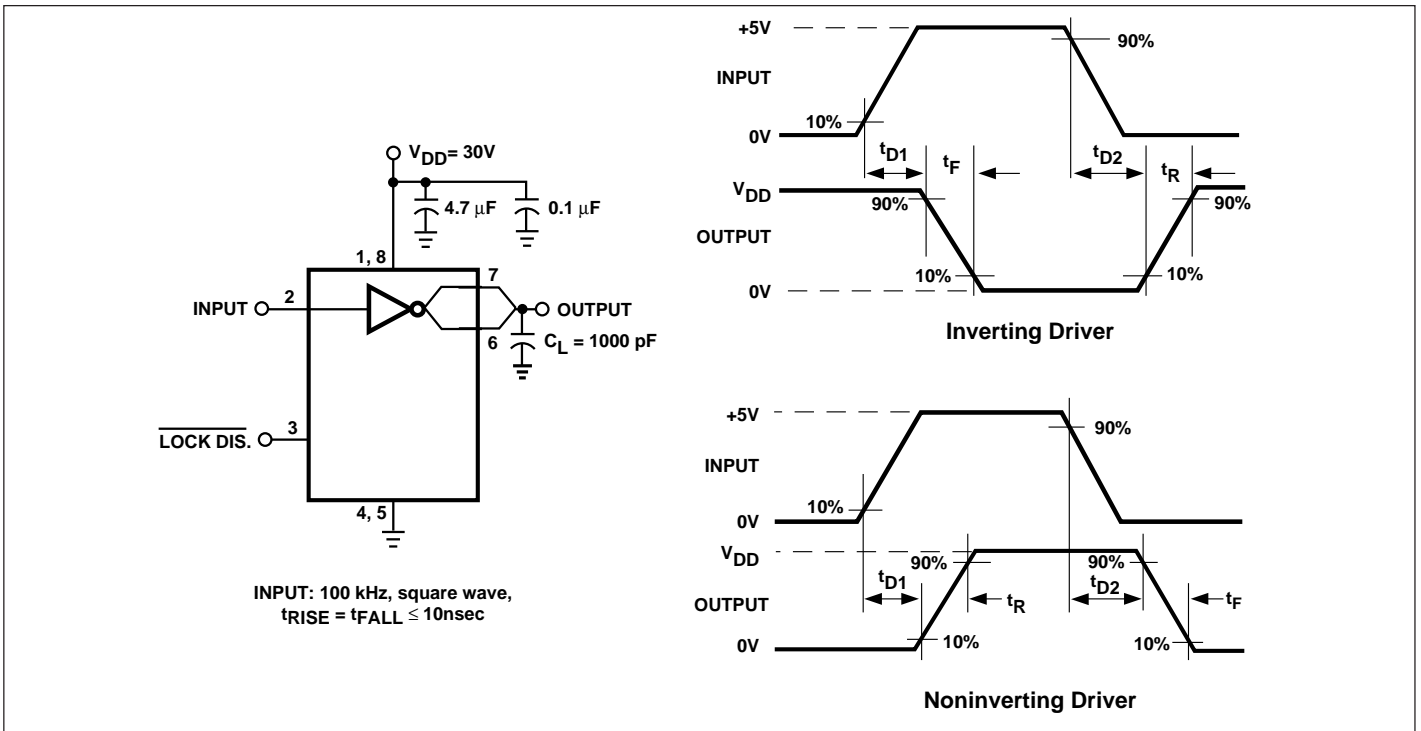

Figure 1. Switching Time Test Circuit

TYPICAL CHARACTERISTICS

